

# DATA SHEET

勝特力材料 886-3-5753170  
勝特力电子(上海) 86-21-34970699  
勝特力电子(深圳) 86-755-83298787  
[Http://www.100y.com.tw](http://www.100y.com.tw)

## 74LV4053

Triple 2-channel analog  
multiplexer/demultiplexer

Product specification  
Supersedes data of 1997 Jul 15  
IC24 Data Handbook

1998 Jun 23

## Triple 2-channel analog multiplexer/demultiplexer

74LV4053

## FEATURES

- Optimized for low voltage applications: 1.0 to 6.0 V
- Accepts TTL input levels between  $V_{CC} = 2.7$  V and  $V_{CC} = 3.6$  V
- Low typ "ON" resistance:
  - 100  $\Omega$  at  $V_{CC} - V_{EE} = 4.5$  V
  - 150  $\Omega$  at  $V_{CC} - V_{EE} = 3.0$  V
  - 240  $\Omega$  at  $V_{CC} - V_{EE} = 2.0$  V
- Logic level translation: to enable 3 V logic to communicate with  $\pm 3$  V analog signals
- Typical "break before make" built in
- Output capability: non-standard
- $I_{CC}$  category: MSI

## DESCRIPTION

The 74LV4053 is a low-voltage CMOS device and is pin and function compatible with the 74HC/HCT4053.

The 74LV4053 is a triple 2-channel analog multiplexer/demultiplexer with a common enable input ( $\bar{E}$ ). Each multiplexer/demultiplexer has two independent inputs/outputs ( $nY_0$  to  $nY_1$ ), a common input/output ( $nZ$ ) and three digital select inputs ( $S_1$  to  $S_3$ ).

With  $\bar{E}$  LOW, one of the two switches is selected (low impedance ON-state) by  $S_1$  to  $S_3$ . With  $\bar{E}$  HIGH, all switches are in the high impedance OFF-states, independent of  $S_1$  and  $S_3$ .

$V_{CC}$  and GND are the supply voltage pins for the digital control inputs ( $S_1$ , to  $S_3$ , and  $\bar{E}$ ). The  $V_{CC}$  to GND ranges are 1.0 to 6.0 V. The analog inputs/outputs ( $nY_0$ , to  $nY_1$ , and  $nZ$ ) can swing between  $V_{CC}$  as a positive limit and  $V_{EE}$  as a negative limit.  $V_{CC} - V_{EE}$  may not exceed 6.0 V. For operation as a digital multiplexer/demultiplexer,  $V_{EE}$  is connected to GND (typically ground).

## QUICK REFERENCE DATA

GND = 0 V;  $T_{amb} = 25^\circ\text{C}$ ;  $t_r = t_f \leq 2.5$  ns

SYMBOL	PARAMETER	CONDITIONS	TYPICAL	UNIT
$t_{pZH}/t_{pZL}$	Turn "ON" time $\bar{E}$ to $V_{OS}$ $S_n$ to $V_{OS}$	$C_L = 15$ pF $R_L = 1K\Omega$ $V_{CC} = 3.3$ V	16 20	ns
$t_{pHZ}/t_{pLZ}$	Turn "OFF" time $\bar{E}$ to $V_{OS}$ $S_n$ to $V_{OS}$		17 16	
$C_I$	Input capacitance		3.5	pF
$C_{PD}$	Power dissipation capacitance per switch	See Notes 1 and 2	36	
$C_S$	Maximum switch capacitance independent (Y) common (Z)		5 8	

## NOTES:

- $C_{PD}$  is used to determine the dynamic power dissipation ( $P_D$  in  $\mu\text{W}$ )  
 $P_D = C_{PD} \times V_{CC}^2 \times f_i + \sum ((C_L + C_S) \times V_{CC}^2 \times f_o)$  where:  
 $f_i$  = input frequency in MHz;  $C_L$  = output load capacity in pF;  
 $f_o$  = output frequency in MHz;  $C_S$  = maximum switch capacitance in pF;  
 $V_{CC}$  = supply voltage in V;  
 $\sum ((C_L + C_S) \times V_{CC}^2 \times f_o)$  = sum of the outputs.
- The condition is  $V_I = \text{GND to } V_{CC}$ .

勝特力材料 886-3-5753170  
 勝特力电子(上海) 86-21-34970699  
 勝特力电子(深圳) 86-755-83298787  
[Http://www.100y.com.tw](http://www.100y.com.tw)

## ORDERING INFORMATION

PACKAGES	TEMPERATURE RANGE	OUTSIDE NORTH AMERICA	NORTH AMERICA	PKG. DWG. #
16-Pin Plastic DIL	$-40^\circ\text{C}$ to $+125^\circ\text{C}$	74LV4053 N	74LV4053 N	SOT38-1
16-Pin Plastic SO	$-40^\circ\text{C}$ to $+125^\circ\text{C}$	74LV4053 D	74LV4053 D	SOT109-1
16-Pin Plastic SSOP Type II	$-40^\circ\text{C}$ to $+125^\circ\text{C}$	74LV4053 DB	74LV4053 DB	SOT338-1
16-Pin Plastic TSSOP Type I	$-40^\circ\text{C}$ to $+125^\circ\text{C}$	74LV4053 PW	74LV4053PW DH	SOT403-1

## PIN CONFIGURATION

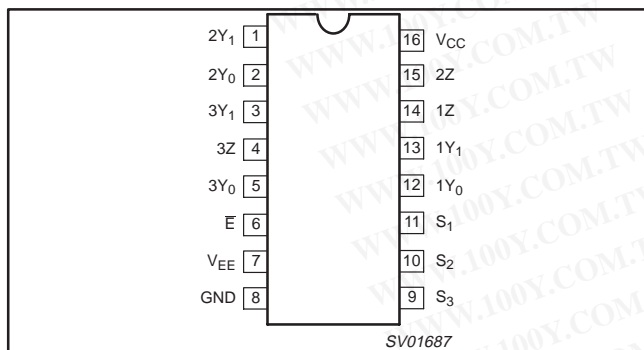

## PIN DESCRIPTION

PIN NUMBER	SYMBOL	FUNCTION
2, 1	$2Y_0, 2Y_1$	Independent inputs/outputs
5, 3	$3Y_0, 3Y_1$	Independent inputs/outputs
6	$\bar{E}$	Enable input (active LOW)
7	$V_{EE}$	Negative supply voltage
8	GND	Ground (0 V)
11, 10, 9	$S_1$ to $S_3$	Select inputs
12, 13	$1Y_0, 1Y_1$	Independent inputs/outputs
14, 15, 4	$1Z$ to $3Z$	Common inputs/outputs
16	$V_{CC}$	Positive supply voltage

# Triple 2-channel analog multiplexer/demultiplexer

## 74LV4053

### LOGIC SYMBOL

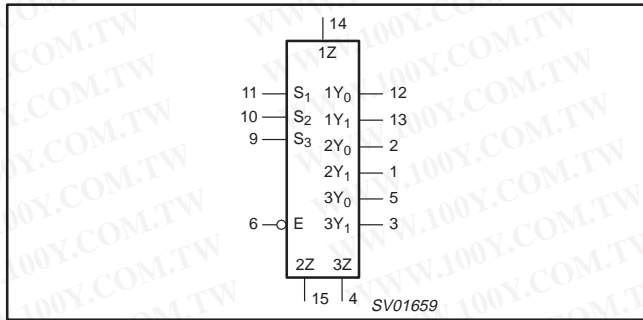

### FUNCTIONAL DIAGRAM

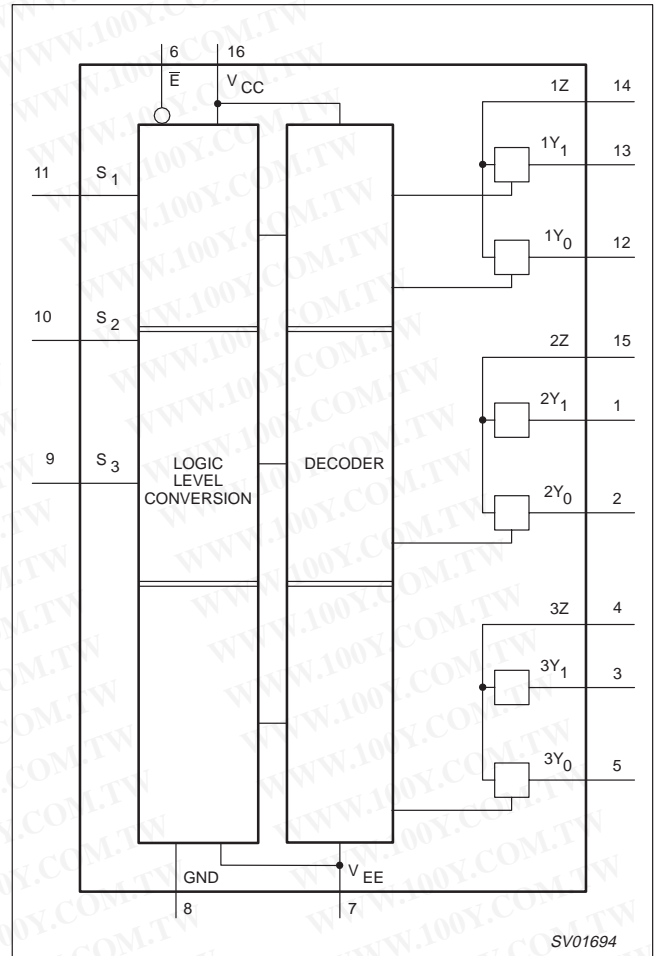

### LOGIC SYMBOL (IEEE/IEC)

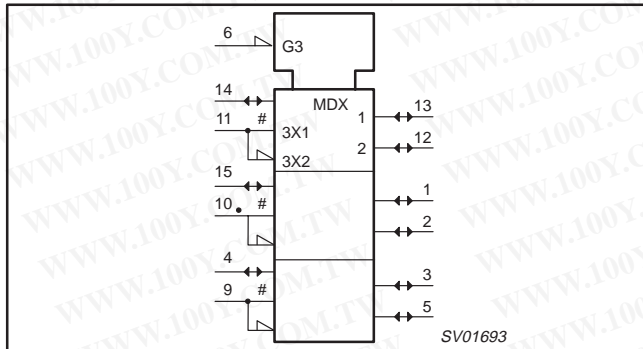

### FUNCTION TABLE

INPUTS		CHANNEL ON
$\bar{E}$	$S_n$	
L	L	$nY_0 - nZ$
L	H	$nY_1 - nZ$
H	X	None

#### NOTES:

- H = HIGH voltage level
- L = LOW voltage level
- X = don't care

勝特力材料 886-3-5753170  
 勝特力电子(上海) 86-21-34970699  
 勝特力电子(深圳) 86-755-83298787  
[Http://www.100y.com.tw](http://www.100y.com.tw)

### SCHEMATIC DIAGRAM (ONE SWITCH)

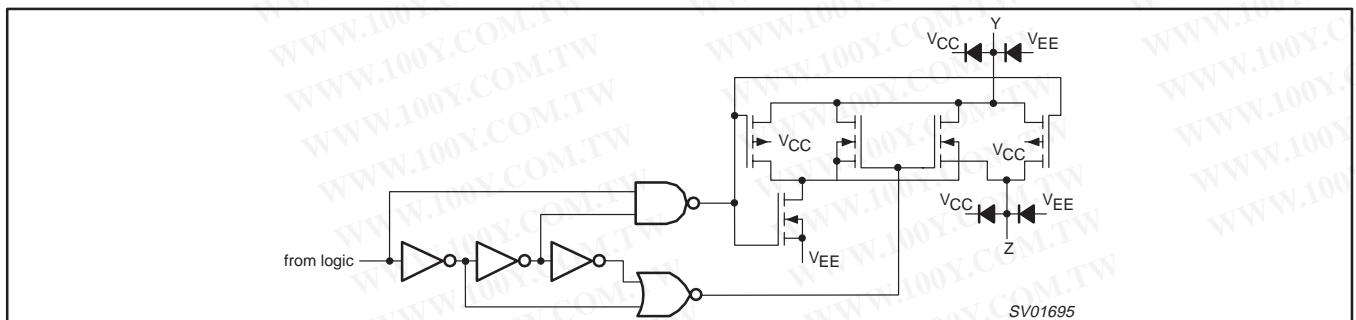

## Triple 2-channel analog multiplexer/demultiplexer

74LV4053

**ABSOLUTE MAXIMUM RATINGS<sup>1, 2</sup>**

In accordance with the Absolute Maximum Rating System (IEC 134).  
 Voltages are referenced to GND (ground = 0 V).

SYMBOL	PARAMETER	CONDITIONS	RATING	UNIT
$V_{CC}$	DC supply voltage		-0.5 to +7.0	V
$\pm I_{IK}$	DC input diode current	$V_I < -0.5$ or $V_I > V_{CC} + 0.5$ V	20	mA
$\pm I_{SK}$	DC switch diode current	$V_O < -0.5$ or $V_O > V_{CC} + 0.5$ V	20	mA
$\pm I_S$	DC switch current	$-0.5$ V $< V_S < V_{CC} + 0.5$ V	25	mA
$T_{stg}$	Storage temperature range		-65 to +150	°C
$P_{TOT}$	Power dissipation per package – plastic DIL – plastic mini-pack (SO) – plastic shrink mini-pack (SSOP and TSSOP)	for temperature range: -40 to +125°C above +70°C derate linearly with 12 mW/K above +70°C derate linearly with 8 mW/K above +60°C derate linearly with 5.5 mW/K	750 500 400	mW

**NOTES:**

- Stresses beyond those listed may cause permanent damage to the device. These are stress ratings only and functional operation of the device at these or any other conditions beyond those indicated under “recommended operating conditions” is not implied. Exposure to absolute-maximum-rated conditions for extended periods may affect device reliability.
- The input and output voltage ratings may be exceeded if the input and output current ratings are observed.

**RECOMMENDED OPERATING CONDITIONS**

SYMBOL	PARAMETER	CONDITIONS	MIN	TYP	MAX	UNIT
$V_{CC}$	DC supply voltage	See Note 1 and Figure 5	1.0	3.3	6.0	V
$V_I$	Input voltage		0	–	$V_{CC}$	V
$V_O$	Output voltage		0	–	$V_{CC}$	V
$T_{amb}$	Operating ambient temperature range in free air	See DC and AC characteristics	-40 -40		+85 +125	°C
$t_r, t_f$	Input rise and fall times	$V_{CC} = 1.0$ V to 2.0 V $V_{CC} = 2.0$ V to 2.7 V $V_{CC} = 2.7$ V to 6.0 V	– – –	– – –	500 200 100	ns/V

**NOTE:**

- The LV is guaranteed to function down to  $V_{CC} = 1.0$  V (input levels GND or  $V_{CC}$ ); DC characteristics are guaranteed from  $V_{CC} = 1.2$  V to  $V_{CC} = 6.0$  V.

勝特力材料 886-3-5753170  
 勝特力电子(上海) 86-21-34970699  
 勝特力电子(深圳) 86-755-83298787  
[Http://www.100y.com.tw](http://www.100y.com.tw)

# Triple 2-channel analog multiplexer/demultiplexer

# 74LV4053

勝特力材料 886-3-5753170  
 勝特力电子(上海) 86-21-34970699  
 勝特力电子(深圳) 86-755-83298787  
[Http://www.100y.com.tw](http://www.100y.com.tw)

## DC ELECTRICAL CHARACTERISTICS

Over recommended operating conditions, voltages are referenced to GND (ground = 0 V)

SYMBOL	PARAMETER	TEST CONDITIONS	LIMITS					UNIT	
			-40°C to +85°C			-40°C to +125°C			
			MIN	TYP <sup>1</sup>	MAX	MIN	MAX		
V <sub>IH</sub>	HIGH level Input voltage	V <sub>CC</sub> = 1.2 V	0.9			0.9		V	
		V <sub>CC</sub> = 2.0 V	1.4			1.4			
		V <sub>CC</sub> = 2.7 to 3.6 V	2.0			2.0			
		V <sub>CC</sub> = 4.5 V	3.15			3.15			
		V <sub>CC</sub> = 6.0 V	4.20			4.20			
V <sub>IL</sub>	LOW level Input voltage	V <sub>CC</sub> = 1.2 V			0.3		0.3	V	
		V <sub>CC</sub> = 2.0 V			0.6		0.6		
		V <sub>CC</sub> = 2.7 to 3.6 V			0.8		0.8		
		V <sub>CC</sub> = 4.5 V			1.35		1.35		
		V <sub>CC</sub> = 6.0 V			1.80		1.80		
±I <sub>I</sub>	Input leakage current	V <sub>CC</sub> = 3.6 V	V <sub>I</sub> = V <sub>CC</sub> or GND		1.0		1.0	μA	
		V <sub>CC</sub> = 6.0 V			2.0		2.0		
±I <sub>S</sub>	Analog switch OFF-state current per channel	V <sub>CC</sub> = 3.6 V	V <sub>I</sub> = V <sub>IH</sub> or V <sub>IL</sub>  V <sub>SI</sub>   = V <sub>CC</sub> - GND (See Figure 2)		1.0		1.0	μA	
		V <sub>CC</sub> = 6.0 V			2.0		2.0		
±I <sub>S</sub>	Analog switch ON-state current	V <sub>CC</sub> = 3.6 V	V <sub>I</sub> = V <sub>IH</sub> or V <sub>IL</sub> V <sub>SI</sub> = V <sub>CC</sub> - GND (See Figure 3)		1.0		1.0	μA	
		V <sub>CC</sub> = 6.0 V			2.0		2.0		
I <sub>CC</sub>	Quiescent supply current	V <sub>CC</sub> = 3.6 V	V <sub>I</sub> = V <sub>CC</sub> or GND		20.0		40	μA	
		V <sub>CC</sub> = 6.0 V	V <sub>IS</sub> = GND or V <sub>CC</sub> ; V <sub>OS</sub> = V <sub>CC</sub> or GND		40.0		80		
ΔI <sub>CC</sub>	Additional quiescent supply current per input	V <sub>CC</sub> = 2.7 to 3.6 V	V <sub>I</sub> = V <sub>CC</sub> - 0.6 V		500		850	μA	
R <sub>ON</sub>	ON-resistance (peak)	V <sub>CC</sub> = 1.2 V	I <sub>S</sub> = 100 μA; V <sub>IS</sub> = V <sub>CC</sub> to GND; V <sub>I</sub> = V <sub>IH</sub> or V <sub>IL</sub>					Ω	
		V <sub>CC</sub> = 2.0 V			180	365	435		
		V <sub>CC</sub> = 2.7 V			115	225	270		
		V <sub>CC</sub> = 3.0 to 3.6 V		I <sub>S</sub> = 1000 μA; V <sub>IS</sub> = V <sub>CC</sub> to GND; V <sub>I</sub> = V <sub>IH</sub> or V <sub>IL</sub>		100	200		245
		V <sub>CC</sub> = 4.5 V				75	150		180
V <sub>CC</sub> = 6.0 V		70	140		165				
R <sub>ON</sub>	ON-resistance (rail)	V <sub>CC</sub> = 1.2 V	I <sub>S</sub> = 100 μA; V <sub>IS</sub> = GND; V <sub>I</sub> = V <sub>IH</sub> or V <sub>IL</sub>		250			Ω	
		V <sub>CC</sub> = 2.0 V			120	280	325		
		V <sub>CC</sub> = 2.7 V		I <sub>S</sub> = 1000 μA; V <sub>IS</sub> = GND; V <sub>I</sub> = V <sub>IH</sub> or V <sub>IL</sub>		75	170		195
		V <sub>CC</sub> = 3.0 to 3.6 V				70	155		180
		V <sub>CC</sub> = 4.5 V				50	120		135
V <sub>CC</sub> = 6.0 V		45	105		120				
R <sub>ON</sub>	ON-resistance (rail)	V <sub>CC</sub> = 1.2 V	V <sub>I</sub> = V <sub>IH</sub> or V <sub>IL</sub> ; I <sub>S</sub> = 100 μA; V <sub>IS</sub> = V <sub>CC</sub>		350			Ω	
		V <sub>CC</sub> = 2.0 V			170	340	400		
		V <sub>CC</sub> = 2.7 V		V <sub>I</sub> = V <sub>IH</sub> or V <sub>IL</sub> ; I <sub>S</sub> = 1000 μA; V <sub>IS</sub> = V <sub>CC</sub>		105	210		250
		V <sub>CC</sub> = 3.0 to 3.6 V				95	190		225
		V <sub>CC</sub> = 4.5 V				70	140		165
V <sub>CC</sub> = 6.0 V		65	125		150				

# Triple 2-channel analog multiplexer/demultiplexer

# 74LV4053

## DC ELECTRICAL CHARACTERISTICS (Continued)

SYMBOL	PARAMETER	TEST CONDITIONS	LIMITS					UNIT		
			-40°C to +85°C			-40°C to +125°C				
			MIN	TYP <sup>1</sup>	MAX	MIN	MAX			
$\Delta R_{ON}$	Maximum variation of ON-resistance between any two channels	$V_{CC} = 1.2\text{ V}$ $V_{CC} = 2.0\text{ V}$ $V_{CC} = 2.7\text{ V}$ $V_{CC} = 3.0\text{ to }3.6\text{ V}$ $V_{CC} = 4.5\text{ V}$ $V_{CC} = 6.0\text{ V}$	$V_I = V_{IH}\text{ or }V_{IL};$ $V_{IS} = V_{CC}\text{ to GND}$							$\Omega$
				5						
				4						
				4						
				3						
				2						

**NOTES:**

1. All typical values are measured at  $T_{amb} = 25^\circ\text{C}$ .
2. At supply voltages approaching 1.2 V, the analog switch ON-resistance becomes extremely non-linear. Therefore, it is recommended that these devices be used to transmit digital signals only, when using these supply voltages.

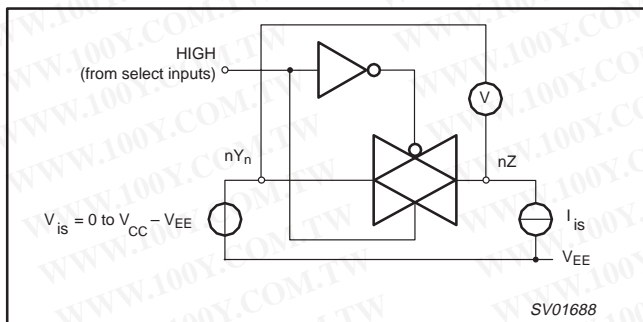

Figure 1. Test circuit for measuring ON-resistance ( $R_{ON}$ ).

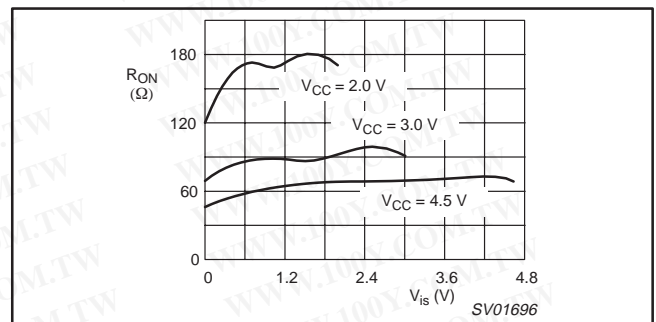

Figure 4. Typical ON-resistance ( $R_{on}$ ) as a function of input voltage ( $V_{is}$ ) for  $V_{is} = 0$  to  $V_{CC} - V_{EE}$ .

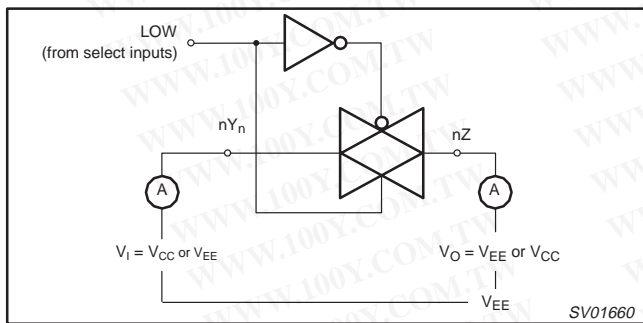

Figure 2. Test circuit for measuring OFF-state current.

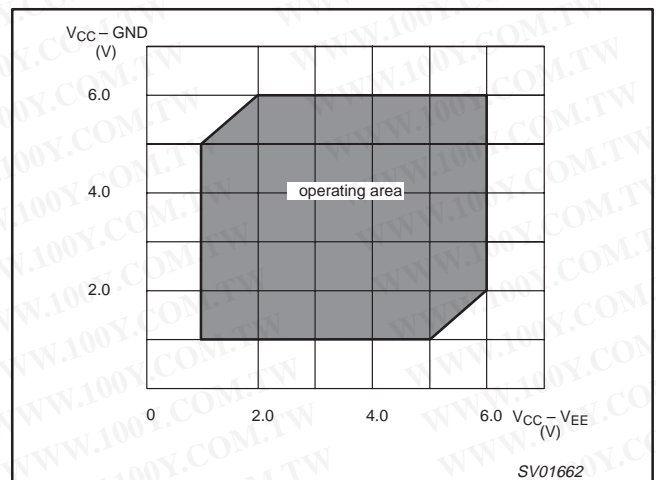

Figure 5. Guaranteed operating area as a function of the supply voltages.

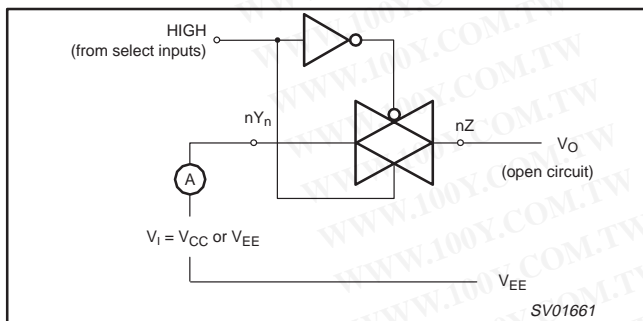

Figure 3. Test circuit for measuring ON-state current.

勝特力材料 886-3-5753170  
 勝特力电子(上海) 86-21-34970699  
 勝特力电子(深圳) 86-755-83298787  
[Http://www.100y.com.tw](http://www.100y.com.tw)

## Triple 2-channel analog multiplexer/demultiplexer

74LV4053

## AC CHARACTERISTICS

GND = 0 V;  $t_r = t_f \leq 2.5\text{ns}$ ;  $C_L = 50\text{pF}$ 

SYMBOL	PARAMETER	CONDITION		LIMITS					UNIT
				-40 to +85 °C			-40 to +125 °C		
		$V_{CC}$ (V)	OTHER	MIN	TYP <sup>1</sup>	MAX	MIN	MAX	
$t_{PHL}/t_{PLH}$	Propagation delay $V_{is}$ to $V_{os}$	1.2	$R_L = \infty$ ; $C_L = 50\text{ pF}$ Figure 12		25				ns
		2.0			9	17		20	
		2.7			6	13		15	
		3.0 to 3.6			5 <sup>2</sup>	10		12	
		4.5			4	9		10	
		6.0			3	7		8	
$t_{PZH}/t_{PZL}$	Turn-on time $\bar{E}$ to $V_{os}$	1.2	$R_L = 1\text{ k}\Omega$ ; $C_L = 50\text{ pF}$ Figures 13 and 1		100				ns
		2.0			34	65		77	
		2.7			25	48		56	
		3.0 to 3.6			19 <sup>2</sup>	38		45	
		4.5			17	32		38	
		6.0			13	25		29	
$t_{PZH}/t_{PZL}$	Turn-on time $S_n$ to $V_{os}$	1.2	$R_L = 1\text{ k}\Omega$ $C_L = 50\text{ pF}$ Figures 13 and 1		125				ns
		2.0			43	82		97	
		2.7			31	60		71	
		3.0 to 3.6			24 <sup>2</sup>	48		57	
		4.5			21	41		48	
		6.0			16	31		37	
$t_{PHZ}/t_{PLZ}$	Turn-off time $\bar{E}$ to $V_{os}$	1.2	$R_L = 1\text{ k}\Omega$ $C_L = 50\text{ pF}$ Figures 13 and 1		95				ns
		2.0			34	61		73	
		2.7			26	46		54	
		3.0 to 3.6			20 <sup>2</sup>	37		44	
		4.5			18	32		38	
		6.0			15	25		30	
$t_{PHZ}/t_{PLZ}$	Turn-off time $S_n$ to $V_{os}$	1.2	$R_L = 1\text{ k}\Omega$ $C_L = 50\text{ pF}$ Figures 13 and 1		90				ns
		2.0			32	59		70	
		2.7			24	44		52	
		3.0 to 3.6			19 <sup>2</sup>	36		42	
		4.5			17	31		36	
		6.0			14	24		28	

## NOTES:

- Unless otherwise stated, all typical values are measured at  $T_{amb} = 25^\circ\text{C}$
- Typical values are measured at  $V_{CC} = 3.3\text{ V}$ .

勝特力材料 886-3-5753170  
 勝特力电子(上海) 86-21-34970699  
 勝特力电子(深圳) 86-755-83298787  
[Http://www.100y.com.tw](http://www.100y.com.tw)

# Triple 2-channel analog multiplexer/demultiplexer

# 74LV4053

勝特力材料 886-3-5753170  
 勝特力电子(上海) 86-21-34970699  
 勝特力电子(深圳) 86-755-83298787  
[Http://www.100y.com.tw](http://www.100y.com.tw)

### ADDITIONAL AC CHARACTERISTICS

Recommended conditions and typical values  
 GND = 0 V;  $t_r = t_f \leq 2.5$  ns

SYMBOL	PARAMETER	TYP.	UNIT	V <sub>CC</sub> (V)	V <sub>is(p-p)</sub> (V)	CONDITIONS
	Sine-wave distortion f = 1 kHz	0.80 0.40	%	3.0 6.0	2.75 5.50	R <sub>L</sub> = 10 kΩ; C <sub>L</sub> = 50 pf Figures 9 and 10
	Sine-wave distortion f = 10 kHz	2.40 1.20	%	3.0 6.0	2.75 5.50	R <sub>L</sub> = 10 kΩ; C <sub>L</sub> = 50 pf Figures 9 and 10
	Switch "OFF" signal feed through	-50 -50	dB	3.0 6.0	Note 1	R <sub>L</sub> = 600 Ω; C <sub>L</sub> = 50 pf; f = 1 MHz Figures 5 and 11
	Crosstalk between any two switches/multiplexers	-60 -60	dB	3.0 6.0	Note 1	R <sub>L</sub> = 600 Ω; C <sub>L</sub> = 50 pf; f = 1 MHz Figure 8
V <sub>(p-p)</sub>	Crosstalk voltage between enable or address input to any switch (peak-to-peak value)	110 120	mV	3.0 6.0		R <sub>L</sub> = 600 Ω; C <sub>L</sub> = 50 pf; f = 1 MHz (S <sub>n</sub> or $\bar{E}$ , square wave between V <sub>CC</sub> and GND $t_r = t_f = 6$ ns) Figure 8
f <sub>max</sub>	Minimum frequency response (-3 dB)	180 200	MHz	3.0 6.0	Note 2	R <sub>L</sub> = 50 Ω; C <sub>L</sub> = 50 pF Figures 6, 8 and 9
C <sub>S</sub>	Maximum switch capacitance	5	pf			

**GENERAL NOTES:**

V<sub>is</sub> is the input voltage at nY<sub>n</sub> or nZ terminal, whichever is assigned as an input.  
 V<sub>OS</sub> is the output voltage at nY<sub>n</sub> or nZ terminal, whichever is assigned as an output.

**NOTES:**

- Adjust input voltage V<sub>is</sub> is 0 dBm level (0 dBm = 1 mW into 600 Ω).
- Adjust input voltage V<sub>is</sub> is 0 dBm level at V<sub>OS</sub> for 1 MHz (0 dBm = 1 mW into 50 Ω).

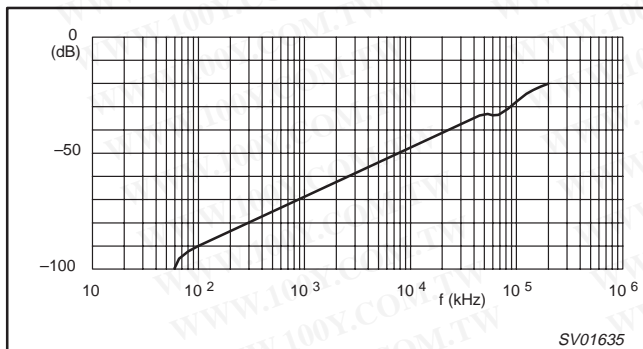

Figure 6. Typical switch "OFF" signal feed-through as a function of frequency.

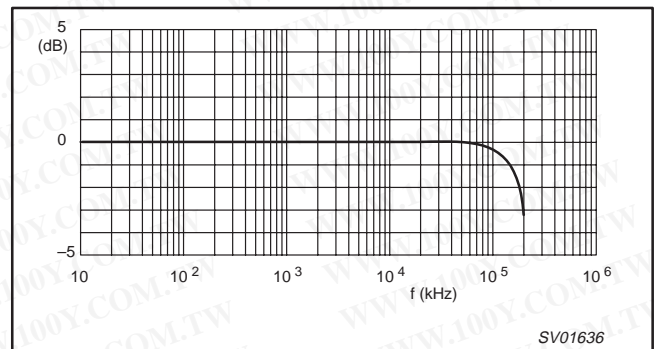

Figure 7. Typical frequency response.

**NOTES TO FIGURES 6 AND 7:**

Test conditions: V<sub>CC</sub> = 3.0 V; GND = 0 V; V<sub>EE</sub> = -3.0V; R<sub>L</sub> = 50 Ω; R<sub>SOURCE</sub> = 1kΩ.

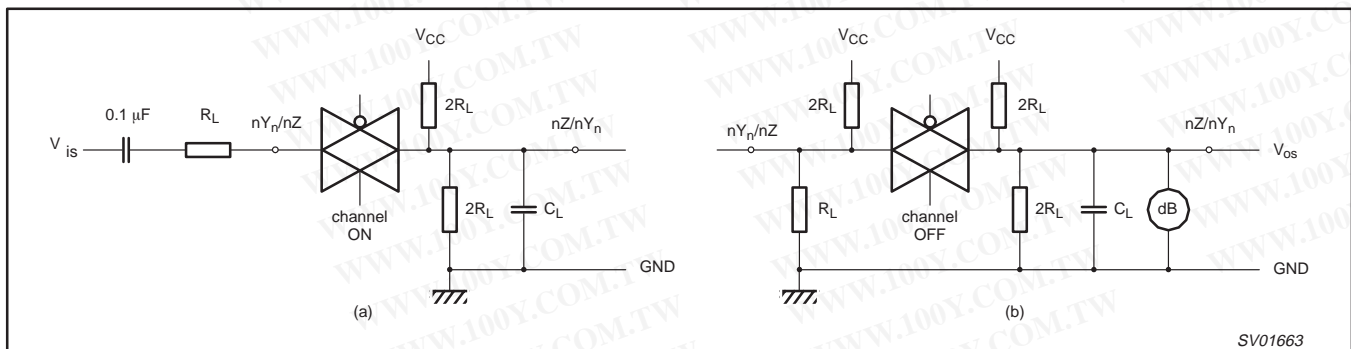

Figure 8. Test circuit for measuring crosstalk between any two switches. (a) channel ON condition; (b) channel OFF condition.



# Triple 2-channel analog multiplexer/demultiplexer

## 74LV4053

**NOTE TO FIGURE 8:**

The crosstalk is defined as follows (oscilloscope output):

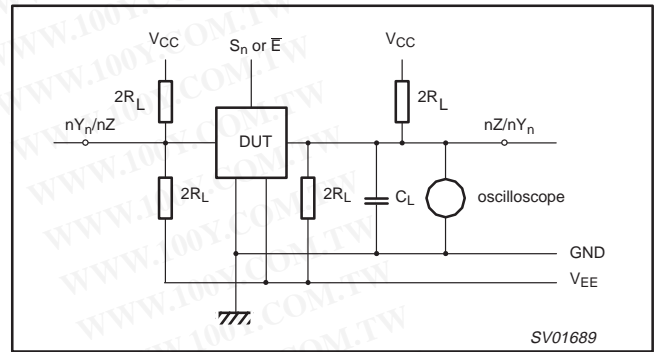
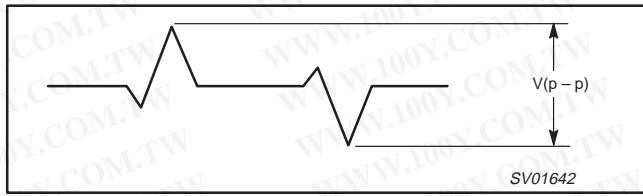

**Figure 9. Test circuit for measuring crosstalk between control and any switch.**

**NOTE TO FIGURE 9:**

Adjust input voltage to obtain 0 dBm at  $V_{OS}$  when  $F_{in} = 1$  MHz. After set-up frequency of  $f_{in}$  is increased to obtain a reading of  $-3$  dB at  $V_{OS}$ .

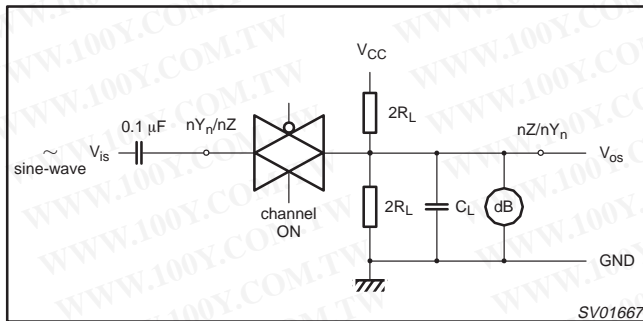

**Figure 10. Test circuit for measuring minimum frequency response.**

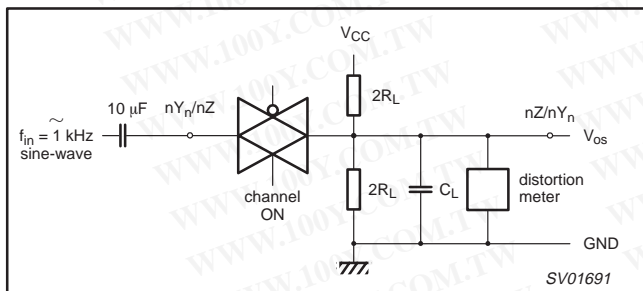

**Figure 11. Test circuit for measuring sine-wave distortion.**

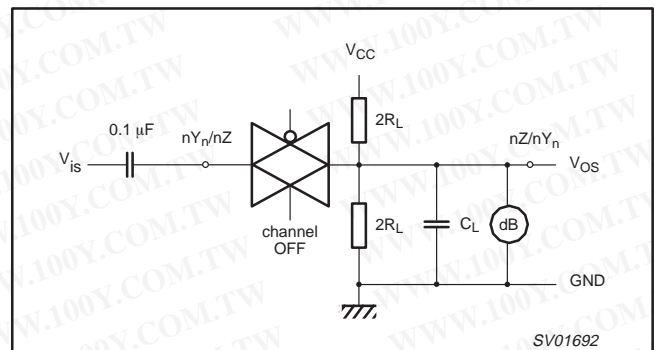

**Figure 12. Test circuit for measuring switch "OFF" signal feed-through.**

勝特力材料 886-3-5753170  
 勝特力电子(上海) 86-21-34970699  
 勝特力电子(深圳) 86-755-83298787  
[Http://www.100y.com.tw](http://www.100y.com.tw)

# Triple 2-channel analog multiplexer/demultiplexer

# 74LV4053

## WAVEFORMS

$V_M = 1.5\text{ V}$  at  $2.7\text{ V} \leq V_{CC} \leq 3.6\text{ V}$   
 $V_M = 0.5 \times V_{CC}$  at  $2.7\text{ V} > V_{CC} > 3.6\text{ V}$   
 $V_{OL}$  and  $V_{OH}$  are the typical output voltage drop that occur with the output load  
 $V_X = V_{OL} + 0.3\text{ V}$  at  $2.7\text{ V} \leq V_{CC} \leq 3.6\text{ V}$   
 $V_X = V_{OL} + 0.1 \times V_{CC}$  at  $2.7\text{ V} > V_{CC} > 3.6\text{ V}$   
 $V_Y = V_{OH} - 0.3\text{ V}$  at  $2.7\text{ V} \leq V_{CC} \leq 3.6\text{ V}$   
 $V_Y = V_{OH} - 0.1 \times V_{CC}$  at  $2.7\text{ V} > V_{CC} > 3.6\text{ V}$

勝特力材料 886-3-5753170  
 勝特力电子(上海) 86-21-34970699  
 勝特力电子(深圳) 86-755-83298787  
[Http://www.100y.com.tw](http://www.100y.com.tw)

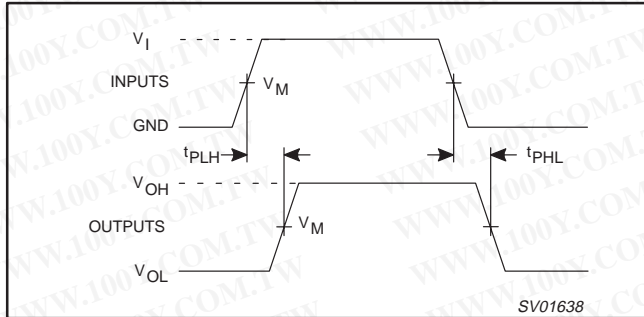

Figure 13. Input ( $V_{IS}$ ) to output ( $V_{OS}$ ) propagation delays.

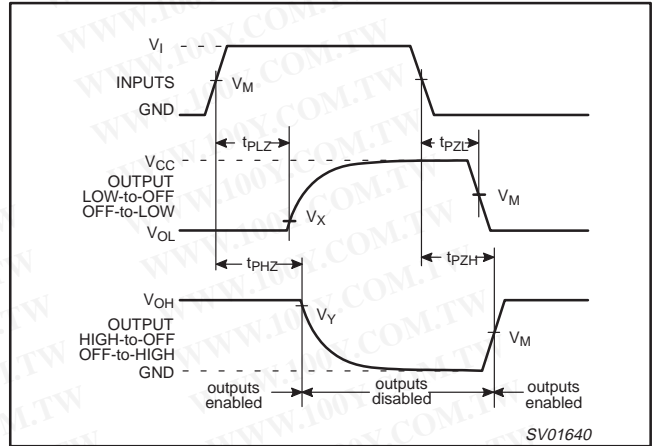

Figure 14. Turn-on and turn-off times for the inputs ( $S_n, \bar{E}$ ) to the output ( $V_{OS}$ ).

## TEST CIRCUIT

### DEFINITIONS

$R_L$  = Load resistor  
 $C_L$  = Load capacitance includes jig and probe capacitance  
 $R_T$  = Termination resistance should be equal to  $Z_{OUT}$  of pulse generators.  
 $t_r = t_f = 6\text{ ns}$ , when measuring  $f_{max}$ , there is no constraint on  $t_r, t_f$  with 50% duty factor.

$V_{CC}$	$V_I$
< 2.7V	$V_{CC}$
2.7 - 3.6V	2.7V
> 3.6 V	$V_{CC}$

Test	$S_1$	$V_{IS}$
$t_{PLH}/t_{PHL}$	Open	Pulse
$t_{PLZ}/t_{PZL}$	$2 \cdot V_{CC}$	$V_{EE}$
$t_{PHZ}/t_{PZH}$	$V_{EE}$	$V_I$

SY01738

Figure 15. Load circuitry for switching times.

Triple 2-channel analog multiplexer/demultiplexer

74LV4053

DIP16: plastic dual in-line package; 16 leads (300 mil)

SOT38-4

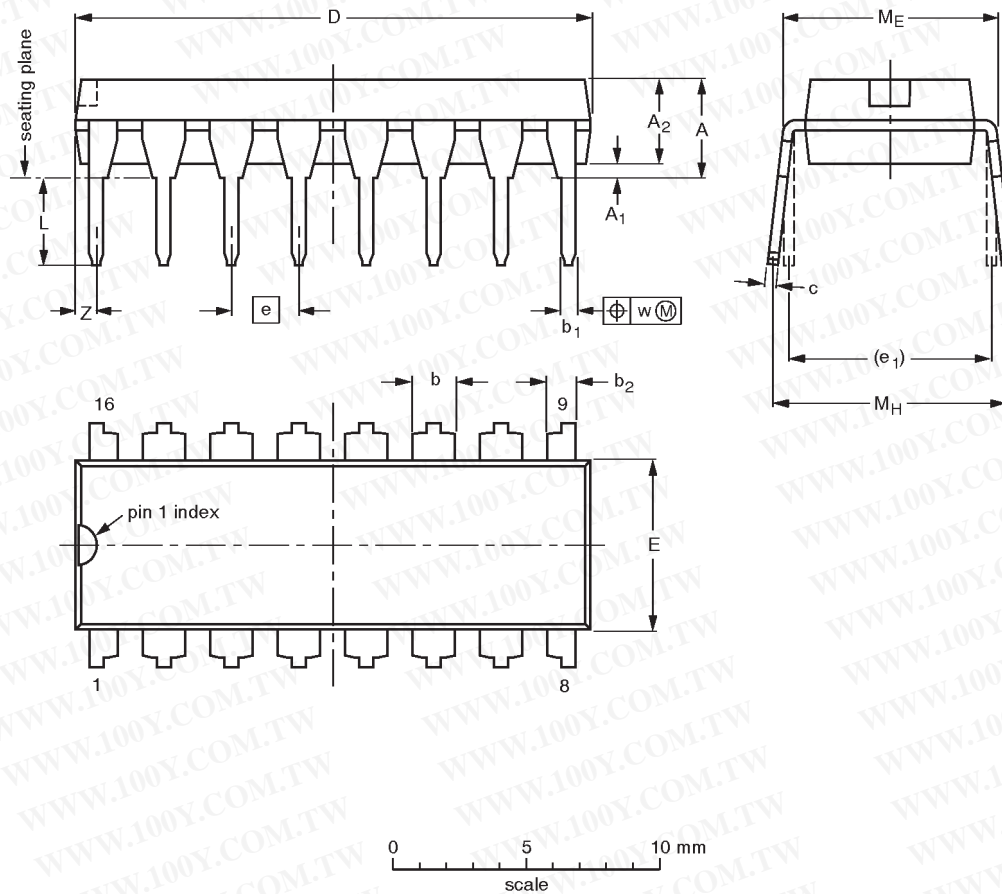

DIMENSIONS (inch dimensions are derived from the original mm dimensions)

UNIT	A max.	A <sub>1</sub> min.	A <sub>2</sub> max.	b	b <sub>1</sub>	b <sub>2</sub>	c	D <sup>(1)</sup>	E <sup>(1)</sup>	e	e <sub>1</sub>	L	M <sub>E</sub>	M <sub>H</sub>	w	Z <sup>(1)</sup> max.
mm	4.2	0.51	3.2	1.73 1.30	0.53 0.38	1.25 0.85	0.36 0.23	19.50 18.55	6.48 6.20	2.54	7.62	3.60 3.05	8.25 7.80	10.0 8.3	0.254	0.76
inches	0.17	0.020	0.13	0.068 0.051	0.021 0.015	0.049 0.033	0.014 0.009	0.77 0.73	0.26 0.24	0.10	0.30	0.14 0.12	0.32 0.31	0.39 0.33	0.01	0.030

Note

1. Plastic or metal protrusions of 0.25 mm maximum per side are not included.

OUTLINE VERSION	REFERENCES			EUROPEAN PROJECTION	ISSUE DATE
	IEC	JEDEC	EIAJ		
SOT38-4					92-11-17 95-01-14

勝特力材料 886-3-5753170  
 勝特力电子(上海) 86-21-34970699  
 勝特力电子(深圳) 86-755-83298787  
[Http://www.100y.com.tw](http://www.100y.com.tw)

Triple 2-channel analog multiplexer/demultiplexer

74LV4053

SO16: plastic small outline package; 16 leads; body width 3.9 mm

SOT109-1

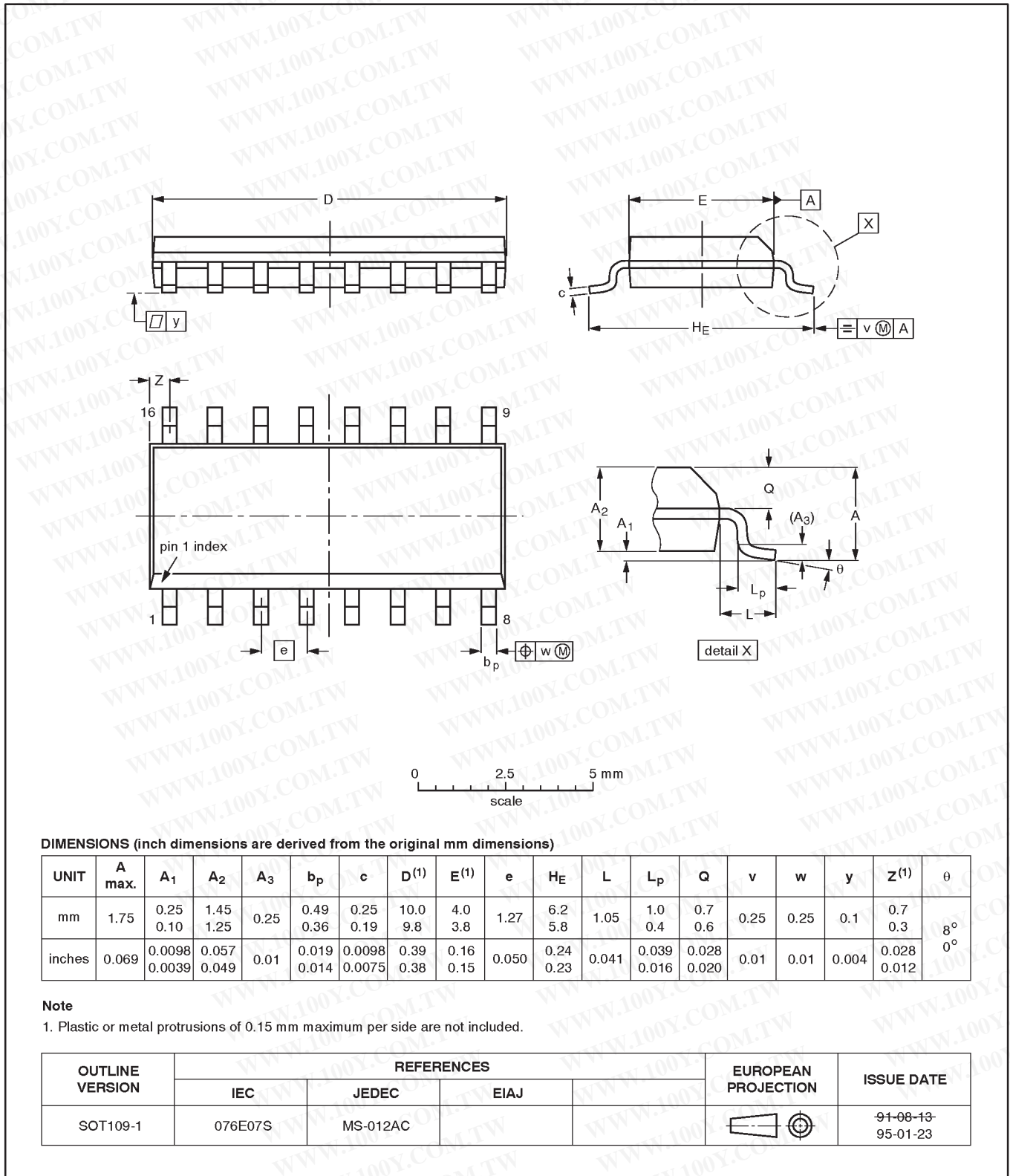

勝特力材料 886-3-5753170  
 勝特力电子(上海) 86-21-34970699  
 勝特力电子(深圳) 86-755-83298787  
[Http://www.100y.com.tw](http://www.100y.com.tw)

Triple 2-channel analog multiplexer/demultiplexer

74LV4053

SSOP16: plastic shrink small outline package; 16 leads; body width 5.3 mm

SOT338-1

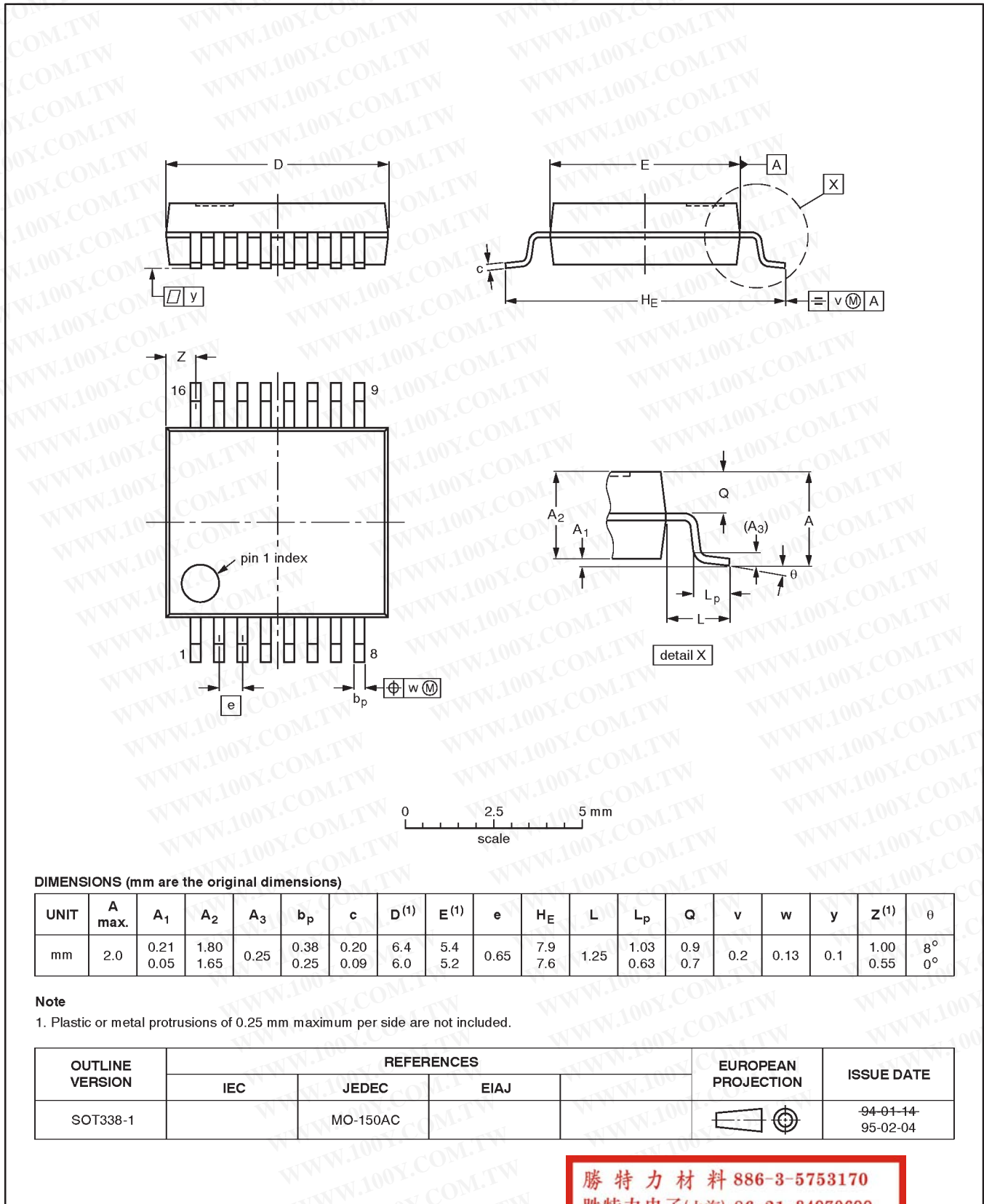

**DIMENSIONS (mm are the original dimensions)**

UNIT	A max.	A <sub>1</sub>	A <sub>2</sub>	A <sub>3</sub>	b <sub>p</sub>	c	D <sup>(1)</sup>	E <sup>(1)</sup>	e	H <sub>E</sub>	L	L <sub>p</sub>	Q	v	w	y	Z <sup>(1)</sup>	θ
mm	2.0	0.21 0.05	1.80 1.65	0.25	0.38 0.25	0.20 0.09	6.4 6.0	5.4 5.2	0.65	7.9 7.6	1.25	1.03 0.63	0.9 0.7	0.2	0.13	0.1	1.00 0.55	8° 0°

**Note**

1. Plastic or metal protrusions of 0.25 mm maximum per side are not included.

OUTLINE VERSION	REFERENCES			EUROPEAN PROJECTION	ISSUE DATE
	IEC	JEDEC	EIAJ		
SOT338-1		MO-150AC			94-01-14 95-02-04

勝特力材料 886-3-5753170  
 勝特力电子(上海) 86-21-34970699  
 勝特力电子(深圳) 86-755-83298787  
 Http://www.100y.com.tw

# Triple 2-channel analog multiplexer/demultiplexer

## 74LV4053

**TSSOP16:** plastic thin shrink small outline package; 16 leads; body width 4.4 mm

**SOT403-1**

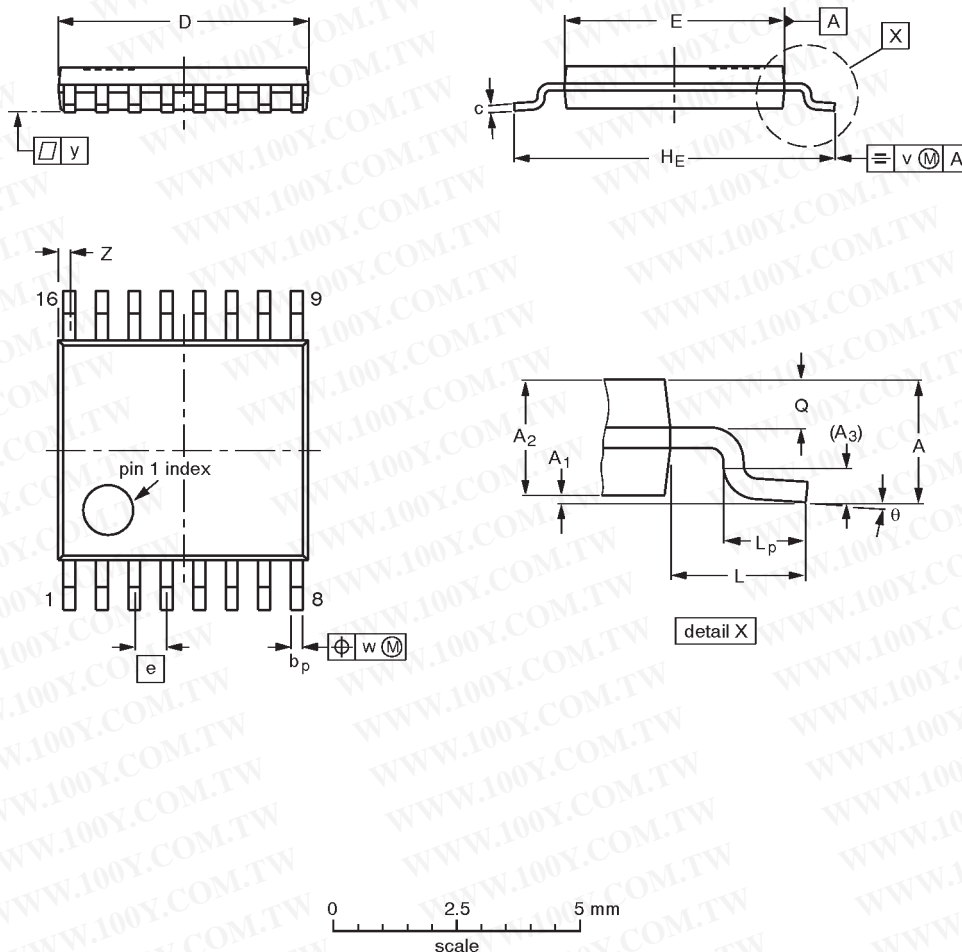

**DIMENSIONS (mm are the original dimensions)**

UNIT	A max.	A <sub>1</sub>	A <sub>2</sub>	A <sub>3</sub>	b <sub>p</sub>	c	D <sup>(1)</sup>	E <sup>(2)</sup>	e	H <sub>E</sub>	L	L <sub>p</sub>	Q	v	w	y	Z <sup>(1)</sup>	θ
mm	1.10	0.15 0.05	0.95 0.80	0.25	0.30 0.19	0.2 0.1	5.1 4.9	4.5 4.3	0.65	6.6 6.2	1.0	0.75 0.50	0.4 0.3	0.2	0.13	0.1	0.40 0.06	8° 0°

**Notes**

1. Plastic or metal protrusions of 0.15 mm maximum per side are not included.
2. Plastic interlead protrusions of 0.25 mm maximum per side are not included.

OUTLINE VERSION	REFERENCES			EUROPEAN PROJECTION	ISSUE DATE
	IEC	JEDEC	EIAJ		
SOT403-1		MO-153			94-07-12 95-04-04

勝特力材料 886-3-5753170  
 勝特力电子(上海) 86-21-34970699  
 勝特力电子(深圳) 86-755-83298787  
[Http://www.100y.com.tw](http://www.100y.com.tw)