

Hex bus buffer with 3-state outputs (non-inverting)

Datasheet - production data

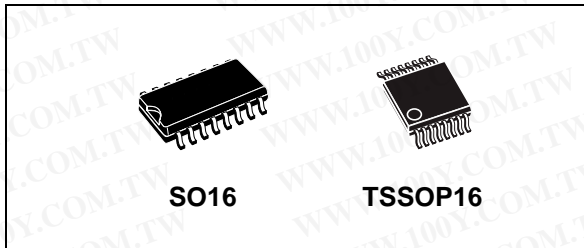

- Pin and function compatible with 74 series 365
- ESD performance
 - HBM: 2 kV
 - MM: 200 V
 - CDM: 1 kV

Description

The M74HC365 is an advanced high-speed CMOS hex bus buffer (3-state) fabricated with silicon gate C²MOS technology.

All six buffers are controlled by the combination of two enable inputs (G1 and G2). All outputs of these buffers are enabled only when both G1 and G2 inputs are held low. Under all other conditions these outputs are disabled in a high-impedance state.

The M74HC365 has non-inverting outputs.

All inputs are equipped with protection circuits against static discharge and transient excess voltage.

Features

- High-speed:
 $t_{PD} = 10 \text{ ns (typ.) at } V_{CC} = 6 \text{ V}$
- Low power dissipation:
 $I_{CC} = 4 \mu\text{A (max.) at } T_A = 25 \text{ }^\circ\text{C}$
- High noise immunity:
 $V_{NIH} = V_{NIL} = 28 \% V_{CC} \text{ (min)}$
- Symmetrical output impedance:
 $|I_{OH}| = I_{OL} = 6 \text{ mA (min.)}$
- Balanced propagation delays:
 $t_{PLH} \cong t_{PHL}$
- Wide operating voltage range:
 $V_{CC} \text{ (opr)} = 2 \text{ V to } 6 \text{ V}$

Table 1. Device summary

Order code	Temp. range	Package	Packing	Marking
M74HC365RM13TR	-55 °C to 125 °C	S016	Tape and reel	74HC365
M74HC365YRM13TR ⁽¹⁾	-40 °C to 125 °C	SO16 (automotive grade)		74HC365Y
M74HC365TTR	-55 °C to 125 °C	TSSOP16		HC365
M74HC365YTTR ⁽¹⁾	-40 °C to 125 °C	TSSOP16 (automotive grade)		HC365Y

1. Qualification and characterization according to AEC Q100 and Q003 or equivalent, advanced screening according to AEC Q001 and Q002 or equivalent.

勝特力材料 886-3-5753170
 勝特力电子(上海) 86-21-34970699
 勝特力电子(深圳) 86-755-83298787
[Http://www.100y.com.tw](http://www.100y.com.tw)

Contents

1	Pin information	3
2	Functional description	4
3	Electrical characteristics	5
4	Package information	10
4.1	SO16 package information	11
4.2	TSSOP16 package information	12
5	Ordering information	13
6	Revision history	13



1 Pin information

Figure 1. Pin connection and IED logic symbols

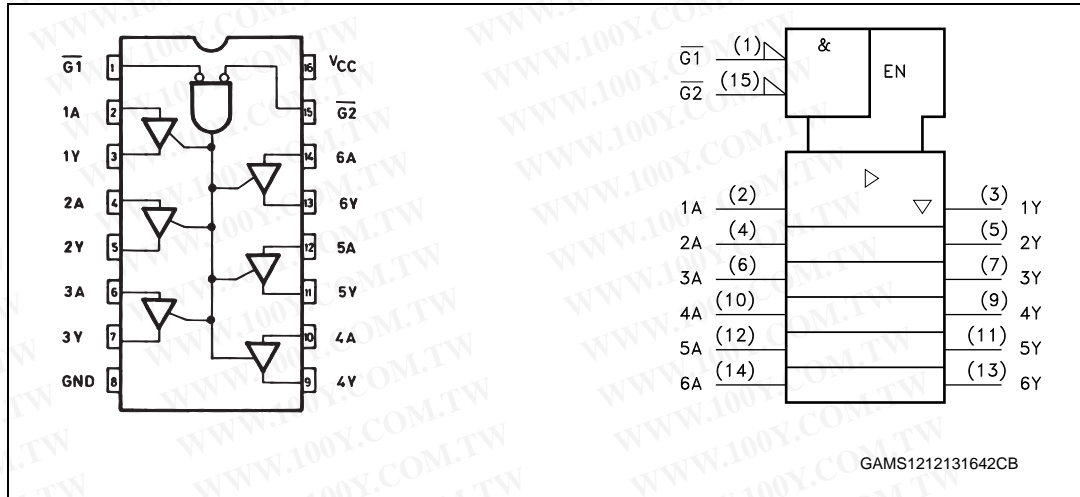

Table 2. Pin description

Pin no	Symbol	Name and function
1, 15	$\overline{G1}, \overline{G2}$	Output enable inputs
2, 4, 6, 10, 12, 14	1A to 6A	Data inputs
3, 5, 7, 9, 11, 13	1Y to 6Y	Data outputs
8	GND	Ground (0 V)
16	V_{CC}	Positive supply voltage

2 Functional description

Table 3. Truth table

Inputs			Outputs
$\overline{G1}$	$\overline{G2}$	An	Y
L	L	L	L
L	L	H	H
H	X ⁽²⁾	X ⁽²⁾	Z ⁽¹⁾
X ⁽²⁾	H	X ⁽²⁾	Z ⁽¹⁾

1. Z = high impedance
2. X = don't care

Figure 2. Input and output equivalent circuit

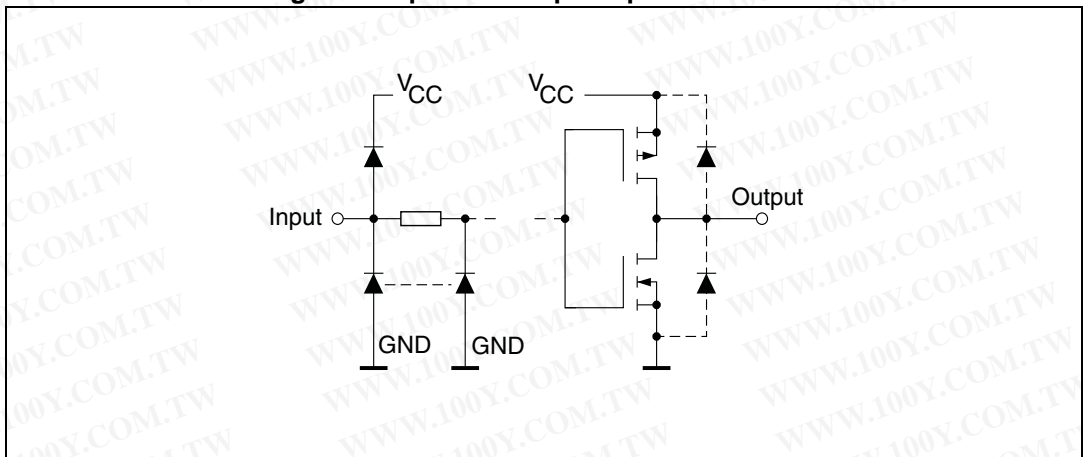

3 Electrical characteristics

“Absolute maximum ratings” are those values beyond which damage to the device may occur. Functional operation under these conditions is not implied.

Table 4. Absolute maximum ratings

Symbol	Parameter	Value	Unit
V_{CC}	Supply voltage	-0.5 to +7	V
V_I	DC input voltage	-0.5 to $V_{CC} + 0.5$	
V_O	DC output voltage		
I_{IK}	DC input diode current	± 20	mA
I_{OK}	DC output diode current	± 35	
I_O	DC output current		
I_{CC} or I_{GND}	DC V_{CC} or ground current	± 70	
P_D	Power dissipation	500 ⁽¹⁾	mW
T_{stg}	Storage temperature	-65 to +150	°C
T_L	Lead temperature (10 sec)	300	

1. 500 mW at 65 °C; derate to 300 mW by 10 mW/°C from 65 °C to 85 °C

Table 5. Recommended operating conditions

Symbol	Parameter	Value	Unit	
V_{CC}	Supply voltage	2 to 6	V	
V_I	Input voltage	0 to V_{CC}		
V_O	Output voltage			
T_{op}	Operating temperature	-55 to 125	°C	
t_r, t_f	Input rise and fall time	$V_{CC} = 2.0\text{ V}$	0 to 1000	ns
		$V_{CC} = 4.5\text{ V}$	0 to 500	
		$V_{CC} = 6.0\text{ V}$	0 to 400	

Table 6. DC specifications

Symbol	Parameter	Test condition		Value						Unit	
		V _{CC} (V)		T _A = 25 °C			-40 to 85 °C		-55 to 125 °C		
				Min.	Typ.	Max.	Min.	Max.	Min.		Max.
V _{IH}	High level input voltage	2.0		1.5			1.5		1.5		V
		4.5		3.15			3.15		3.15		
		6.0		4.2			4.2		4.2		
V _{IL}	Low level input voltage	2.0				0.5		0.5		0.5	V
		4.5				1.35		1.35		1.35	
		6.0				1.8		1.8		1.8	
V _{OH}	High level output voltage	2.0	I _O = -20 μA	1.9	2.0		1.9		1.9		V
		4.5	I _O = -20 μA	4.4	4.5		4.4		4.4		
		6.0	I _O = -20 μA	5.9	6.0		5.9		5.9		
		4.5	I _O = -6.0 mA	4.18	4.31		4.13		4.10		
		6.0	I _O = -7.8 mA	5.68	5.8		5.63		5.60		
V _{OL}	Low level output voltage	2.0	I _O = 20 μA		0.0	0.1		0.1		0.1	V
		4.5	I _O = 20 μA		0.0	0.1		0.1		0.1	
		6.0	I _O = 20 μA		0.0	0.1		0.1		0.1	
		4.5	I _O = 6.0 mA		0.17	0.26		0.33		0.40	
		6.0	I _O = 7.8 mA		0.18	0.26		0.33		0.40	
I _I	Input leakage current	6.0	V _I = V _{CC} or GND			±0.1		±1		±1	μA
I _{OZ}	High impedance output leakage current	6.0	V _I = V _{IH} or V _{IL} V _O = V _{CC} or GND			±0.5		±5		±10	μA
I _{CC}	Quiescent supply current	6.0	V _I = V _{CC} or GND			4		40		80	μA

Table 7. AC electrical characteristics
($C_L = 50$ pF, Input $t_r = t_f = 6$ ns)

Symbol	Parameter	Test condition			Value								Unit
		V_{CC} (V)	C_L (pF)		$T_A = 25\text{ °C}$			$-40\text{ to }85\text{ °C}$		$-55\text{ to }125\text{ °C}$			
					Min.	Typ.	Max.	Min.	Max.	Min.	Max.		
t_{TLH}, t_{THL}	Output transition time	2.0	50		25	60		75		90	ns		
		4.5			7	12		19		18			
		6.0			6	10		13		15			
t_{PLH}, t_{PHL}	Propagation delay time	2.0	50		38	90		115		135	ns		
		4.5			12	18		23		27			
		6.0			10	15		20		23			
		2.0	150		51	130		165		195	ns		
		4.5			17	26		33		39			
		6.0			14	22		28		33			
t_{PZL}, t_{PZH}	High impedance output enable time	2.0	50	$R_L = 1\text{ k}\Omega$	64	130		165		195	ns		
		4.5				16	26		33			39	
		6.0				14	22		28			33	
		2.0	150			76	150		190		225	ns	
		4.5				19	30		38		45		
		6.0				16	26		32		38		
t_{PLZ}, t_{PHZ}	High impedance output disable time	2.0	50	$R_L = 1\text{ k}\Omega$	42	130		165		195	ns		
		4.5				18	26		33			39	
		6.0				15	22		28			33	

Table 8. Capacitive characteristics

Sym	Parameter	Test condition	Value							Unit
			V_{CC} (V)	$T_A = 25\text{ °C}$			$-40\text{ to }85\text{ °C}$		$-55\text{ to }125\text{ °C}$	
		Min		Typ	Max	Min	Max	Min	Max	
C_{IN}	Input capacitance			5	10		10		10	pF
C_{PD}	Power dissipation capacitance ⁽¹⁾	5.0	-	27		-		-		

1. C_{PD} is defined as the value of the IC's internal equivalent capacitance which is calculated from the operating current consumption without load (refer to test circuit). Average operating current can be obtained by the following equation:
 $I_{CC(opr)} = C_{PD} \times V_{CC} \times f_{IN} + I_{CC}/6$ (per gate).

Figure 3. Test circuit

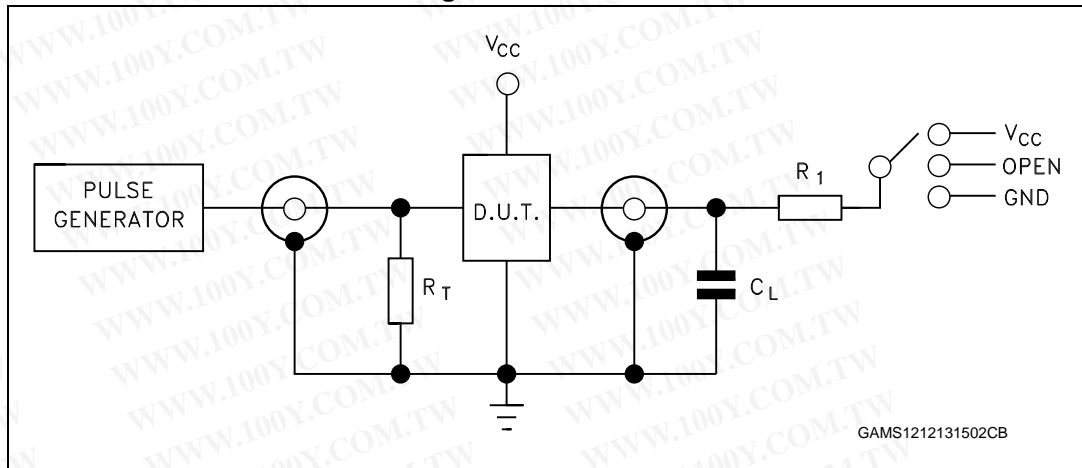

- Legend:
 $C_L = 50 \text{ pF}/150 \text{ pF}$ or equivalent (includes jig and probe capacitance).
 $R_1 = 1 \text{ k}\Omega$ or equivalent.
 $R_T = Z_{OUT}$ of pulse generator (typically 50Ω).

Table 9. Propagation delay time configuration

Test	Switch
t_{PLH}, t_{PHL}	Open
t_{PZL}, t_{PLZ}	V_{CC}
t_{PZH}, t_{PHZ}	GND

Figure 4. Waveform 1: propagation delay times
(f = 1 MHz; 50 % duty cycle)

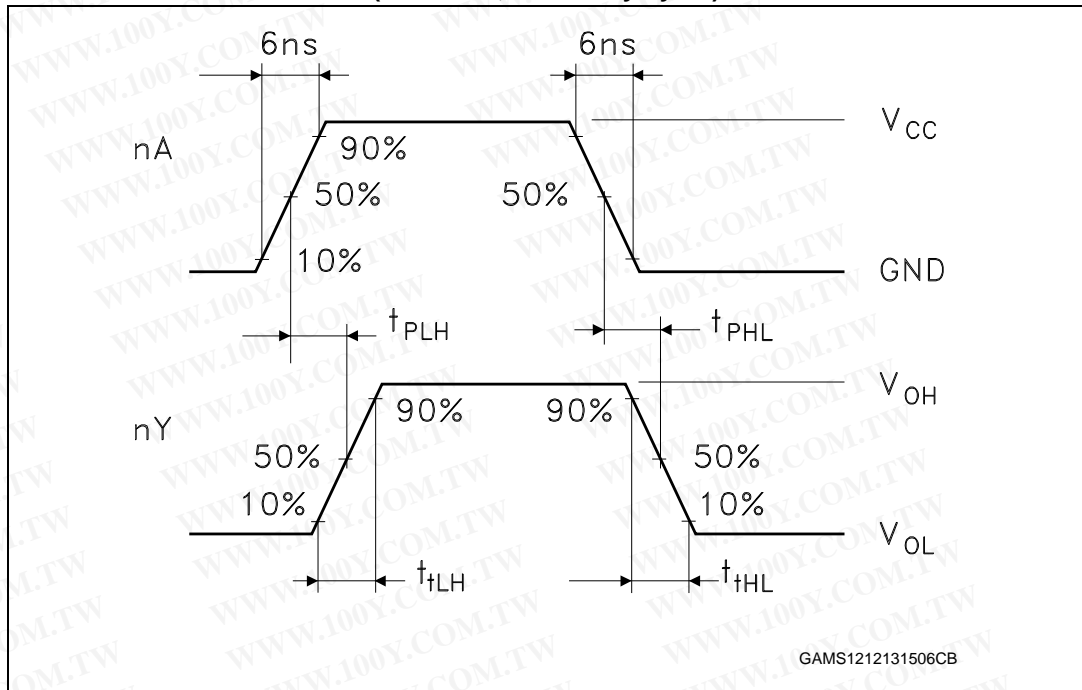
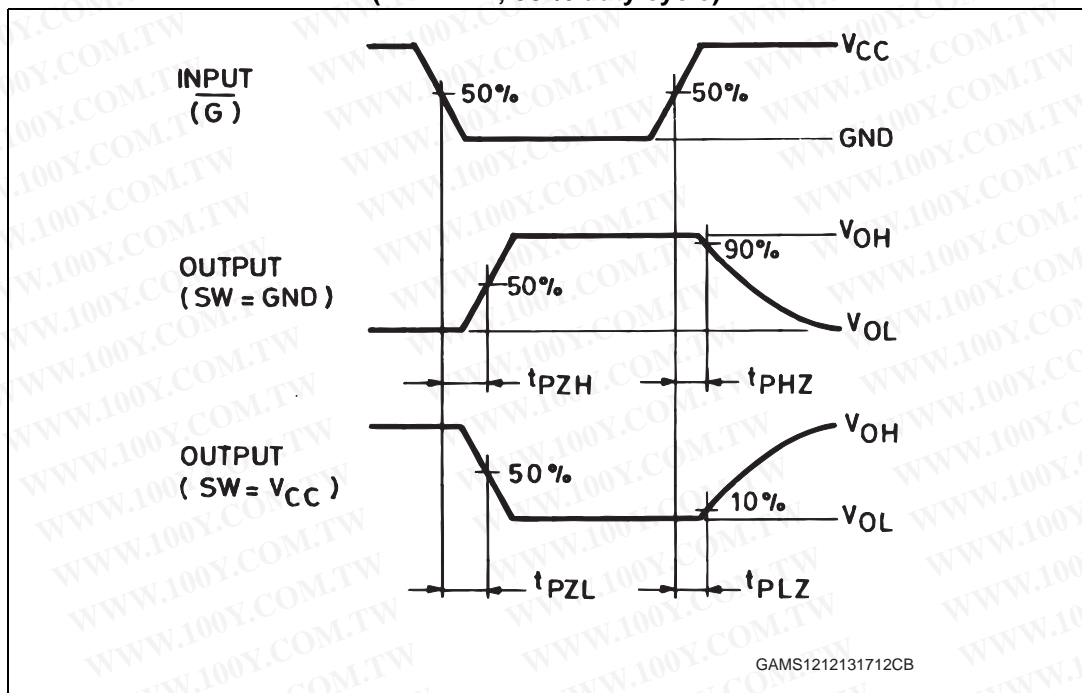

Figure 5. Waveform 2: Output enable and disable times
(f = 1 MHz; 50 % duty cycle)



4 Package information

In order to meet environmental requirements, ST offers these devices in different grades of ECOPACK® packages, depending on their level of environmental compliance. ECOPACK® specifications, grade definitions and product status are available at: www.st.com. ECOPACK® is an ST trademark.

4.1 SO16 package information

Figure 6. SO16 package mechanical drawing

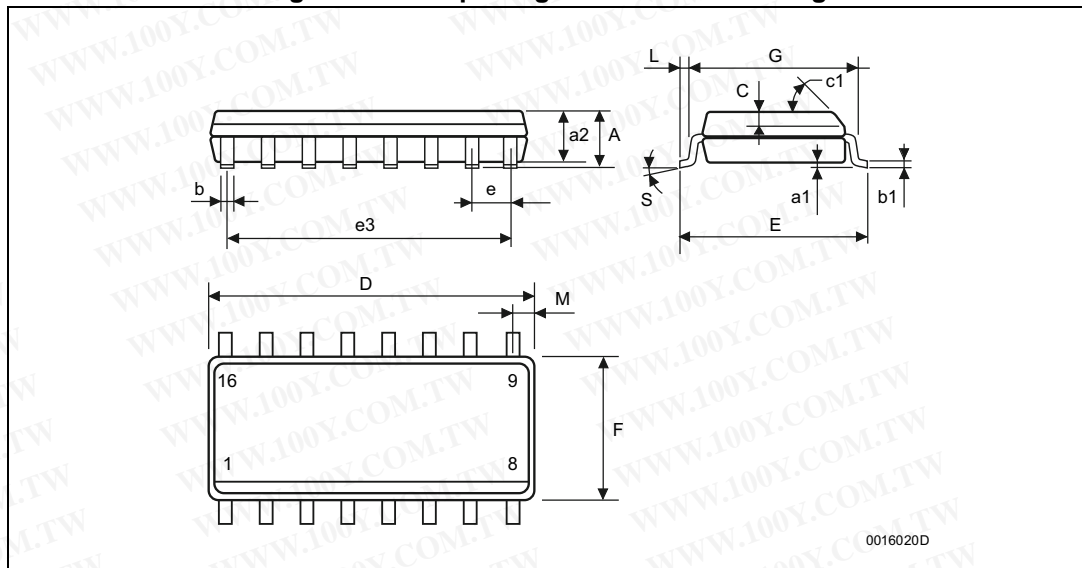

Table 10. SO16 package mechanical data

Symbol	Dimensions					
	mm			inch		
	Min.	Typ.	Max.	Min.	Typ.	Max.
A			1.75			0.068
a1	0.1		0.2	0.003		0.008
a2			1.65			0.064
b	0.35		0.46	0.013		0.018
b1	0.19		0.25	0.007		0.010
C		0.5			0.019	
c1	45° (typ.)					
D	9.8		10	0.385		0.393
E	5.8		6.2	0.228		0.244
e		1.27			0.050	
e3		8.89			0.350	
F	3.8		4.0	0.149		0.157
G	4.6		5.3	0.181		0.208
L	0.5		1.27	0.019		0.050
M			0.62			0.024
S	8° (max.)					

4.2 TSSOP16 package information

Figure 7. TSSOP16 package mechanical drawing

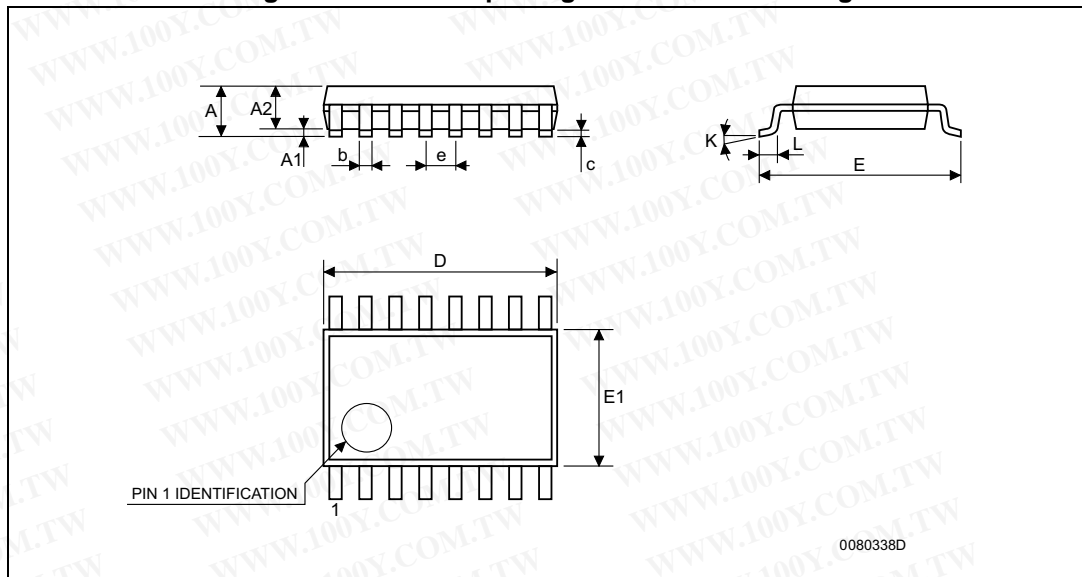

Table 11. TSSOP16 package mechanical data

Symbol	Dimensions					
	mm			inch		
	Min.	Typ.	Max.	Min.	Typ.	Max.
A			1.2			0.047
A1	0.05		0.15	0.002	0.004	0.006
A2	0.8	1	1.05	0.031	0.039	0.041
b	0.19		0.30	0.007		0.012
c	0.09		0.20	0.004		0.0089
D	4.9	5	5.1	0.193	0.197	0.201
E	6.2	6.4	6.6	0.244	0.252	0.260
E1	4.3	4.4	4.48	0.169	0.173	0.176
e		0.65			0.0256	
K	0 °		8 °	0 °		8 °
L	0.45	0.60	0.75	0.018	0.024	0.030

5 Ordering information

Table 12. Order codes

Order code	Temp. range	Package	Packing	Marking
M74HC365RM13TR	-55 °C to 125 °C	S016	Tape and reel	74HC365
M74HC365YRM13TR ⁽¹⁾	-40 °C to 125 °C	SO16 (automotive grade)		74HC365Y
M74HC365TTR	-55 °C to 125 °C	TSSOP16		HC365
M74HC365YTTR ⁽¹⁾	-40 °C to 125 °C	TSSOP16 (automotive grade)		HC365Y

1. Qualification and characterization according to AEC Q100 and Q003 or equivalent, advanced screening according to AEC Q001 and Q002 or equivalent.

6 Revision history

Table 13. Document revision history

Date	Revision	Changes
Aug-2001	1	Initial release.
13-Dec-2013	2	Removed DIP16 package Table 1: Device summary : updated order codes, added automotive grade order codes, added temperature range and marking details. Added Section 5: Ordering information .
13-Jan-2014	3	Added ESD data to Features

勝特力材料 886-3-5753170
勝特力电子(上海) 86-21-34970699
勝特力电子(深圳) 86-755-83298787
[Http://www.100y.com.tw](http://www.100y.com.tw)

Please Read Carefully:

Information in this document is provided solely in connection with ST products. STMicroelectronics NV and its subsidiaries ("ST") reserve the right to make changes, corrections, modifications or improvements, to this document, and the products and services described herein at any time, without notice.

All ST products are sold pursuant to ST's terms and conditions of sale.

Purchasers are solely responsible for the choice, selection and use of the ST products and services described herein, and ST assumes no liability whatsoever relating to the choice, selection or use of the ST products and services described herein.

No license, express or implied, by estoppel or otherwise, to any intellectual property rights is granted under this document. If any part of this document refers to any third party products or services it shall not be deemed a license grant by ST for the use of such third party products or services, or any intellectual property contained therein or considered as a warranty covering the use in any manner whatsoever of such third party products or services or any intellectual property contained therein.

UNLESS OTHERWISE SET FORTH IN ST'S TERMS AND CONDITIONS OF SALE ST DISCLAIMS ANY EXPRESS OR IMPLIED WARRANTY WITH RESPECT TO THE USE AND/OR SALE OF ST PRODUCTS INCLUDING WITHOUT LIMITATION IMPLIED WARRANTIES OF MERCHANTABILITY, FITNESS FOR A PARTICULAR PURPOSE (AND THEIR EQUIVALENTS UNDER THE LAWS OF ANY JURISDICTION), OR INFRINGEMENT OF ANY PATENT, COPYRIGHT OR OTHER INTELLECTUAL PROPERTY RIGHT.

ST PRODUCTS ARE NOT DESIGNED OR AUTHORIZED FOR USE IN: (A) SAFETY CRITICAL APPLICATIONS SUCH AS LIFE SUPPORTING, ACTIVE IMPLANTED DEVICES OR SYSTEMS WITH PRODUCT FUNCTIONAL SAFETY REQUIREMENTS; (B) AERONAUTIC APPLICATIONS; (C) AUTOMOTIVE APPLICATIONS OR ENVIRONMENTS, AND/OR (D) AEROSPACE APPLICATIONS OR ENVIRONMENTS. WHERE ST PRODUCTS ARE NOT DESIGNED FOR SUCH USE, THE PURCHASER SHALL USE PRODUCTS AT PURCHASER'S SOLE RISK, EVEN IF ST HAS BEEN INFORMED IN WRITING OF SUCH USAGE, UNLESS A PRODUCT IS EXPRESSLY DESIGNATED BY ST AS BEING INTENDED FOR "AUTOMOTIVE, AUTOMOTIVE SAFETY OR MEDICAL" INDUSTRY DOMAINS ACCORDING TO ST PRODUCT DESIGN SPECIFICATIONS. PRODUCTS FORMALLY ESCC, QML OR JAN QUALIFIED ARE DEEMED SUITABLE FOR USE IN AEROSPACE BY THE CORRESPONDING GOVERNMENTAL AGENCY.

Resale of ST products with provisions different from the statements and/or technical features set forth in this document shall immediately void any warranty granted by ST for the ST product or service described herein and shall not create or extend in any manner whatsoever, any liability of ST.

ST and the ST logo are trademarks or registered trademarks of ST in various countries.

Information in this document supersedes and replaces all information previously supplied.

The ST logo is a registered trademark of STMicroelectronics. All other names are the property of their respective owners.

© 2014 STMicroelectronics - All rights reserved

STMicroelectronics group of companies

Australia - Belgium - Brazil - Canada - China - Czech Republic - Finland - France - Germany - Hong Kong - India - Israel - Italy - Japan - Malaysia - Malta - Morocco - Philippines - Singapore - Spain - Sweden - Switzerland - United Kingdom - United States of America

www.st.com