

- State-of-the-Art Advanced BiCMOS Technology (ABT) Design for 3.3-V Operation and Low Static Power Dissipation
- Support Mixed-Mode Signal Operation (5-V Input and Output Voltages With 3.3-V  $V_{CC}$ )
- Support Unregulated Battery Operation Down to 2.7 V
- Typical  $V_{OLP}$  (Output Ground Bounce)  $< 0.8$  V at  $V_{CC} = 3.3$  V,  $T_A = 25^\circ\text{C}$
- ESD Protection Exceeds 2000 V Per MIL-STD-883C, Method 3015; Exceeds 200 V Using Machine Model ( $C = 200$  pF,  $R = 0$ )
- Latch-Up Performance Exceeds 500 mA Per JEDEC Standard JESD-17
- Bus-Hold Data Inputs Eliminate the Need for External Pullup Resistors
- Support Live Insertion
- Package Options Include Plastic Small-Outline (DW), Shrink Small-Outline (DB), and Thin Shrink Small-Outline (PW) Packages, Ceramic Chip Carriers (FK), Ceramic Flat (W) Packages, and Ceramic (J) DIPs

SN54LVT573 . . . J OR W PACKAGE  
 SN74LVT573 . . . DB, DW, OR PW PACKAGE  
 (TOP VIEW)

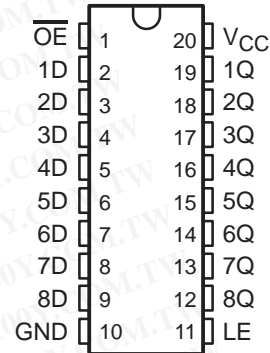

SN54LVT573 . . . FK PACKAGE  
 (TOP VIEW)

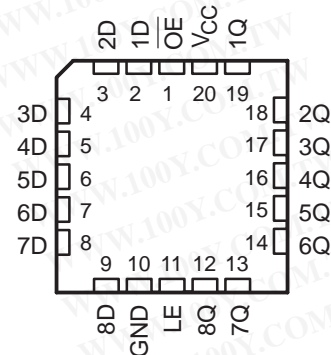

## description

These octal latches are designed specifically for low-voltage (3.3-V)  $V_{CC}$  operation, but with the capability to provide a TTL interface to a 5-V system environment.

The eight latches of the 'LVT573 are transparent D-type latches. While the latch-enable (LE) input is high, the Q outputs follow the data (D) inputs. When LE is taken low, the Q outputs are latched at the logic levels set up at the D inputs.

A buffered output-enable ( $\overline{OE}$ ) input can be used to place the eight outputs in either a normal logic state (high or low logic levels) or a high-impedance state. In the high-impedance state, the outputs neither load nor drive the bus lines significantly. The high-impedance state and increased drive provide the capability to drive bus lines without need for interface or pullup components.  $\overline{OE}$  does not affect the internal operations of the latches. Old data can be retained or new data can be entered while the outputs are in the high-impedance state.

Active bus-hold circuitry is provided to hold unused or floating data inputs at a valid logic level.

To ensure the high-impedance state during power up or power down,  $\overline{OE}$  should be tied to  $V_{CC}$  through a pullup resistor; the minimum value of the resistor is determined by the current-sinking capability of the driver.

The SN74LVT573 is available in TI's shrink small-outline package (DB), which provides the same I/O pin count and functionality of standard small-outline packages in less than half the printed-circuit-board area.

The SN54LVT573 is characterized for operation over the full military temperature range of  $-55^\circ\text{C}$  to  $125^\circ\text{C}$ . The SN74LVT573 is characterized for operation from  $-40^\circ\text{C}$  to  $85^\circ\text{C}$ .



Please be aware that an important notice concerning availability, standard warranty, and use in critical applications of Texas Instruments semiconductor products and disclaimers thereto appears at the end of this data sheet.

**SN54LVT573, SN74LVT573**  
**3.3-V ABT OCTAL TRANSPARENT D-TYPE LATCHES**  
**WITH 3-STATE OUTPUTS**

SCBS138D – MAY 1992 – REVISED JULY 1995

勝特力材料 886-3-5753170  
 勝特力电子(上海) 86-21-34970699  
 勝特力电子(深圳) 86-755-83298787  
[Http://www.100y.com.tw](http://www.100y.com.tw)

**FUNCTION TABLE**  
(each latch)

INPUTS			OUTPUT
$\overline{OE}$	LE	D	Q
L	H	H	H
L	H	L	L
L	L	X	$Q_0$
H	X	X	Z

**logic symbol†**

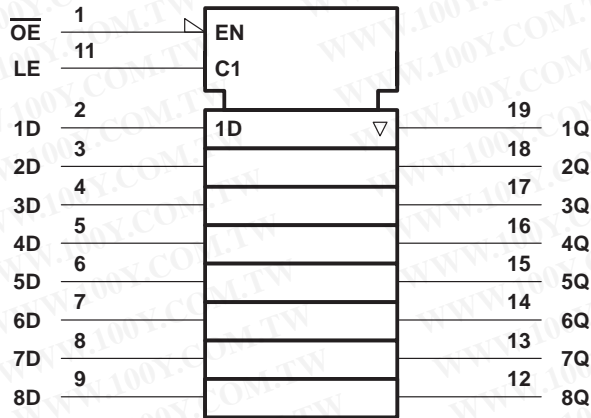

**logic diagram (positive logic)**

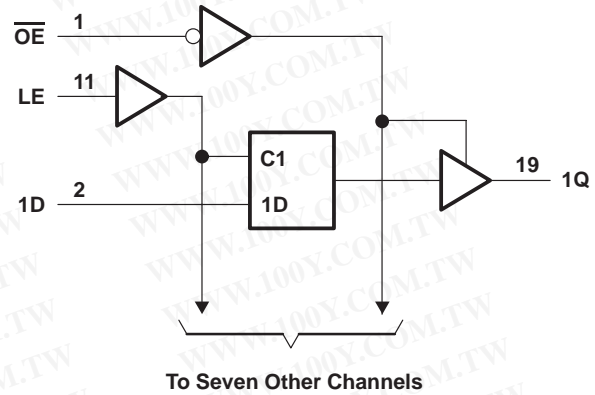

† This symbol is in accordance with ANSI/IEEE Std 91-1984 and IEC Publication 617-12.

**absolute maximum ratings over operating free-air temperature range (unless otherwise noted)‡**

Supply voltage range, $V_{CC}$	–0.5 V to 4.6 V
Input voltage range, $V_I$ (see Note 1)	–0.5 V to 7 V
Voltage range applied to any output in the high state or power-off state, $V_O$ (see Note 1)	–0.5 V to 7 V
Current into any output in the low state, $I_O$ : SN54LVT573	96 mA
SN74LVT573	128 mA
Current into any output in the high state, $I_O$ (see Note 2): SN54LVT573	48 mA
SN74LVT573	64 mA
Input clamp current, $I_{IK}$ ( $V_I < 0$ )	–50 mA
Output clamp current, $I_{OK}$ ( $V_O < 0$ )	–50 mA
Maximum power dissipation at $T_A = 55^\circ\text{C}$ (in still air) (see Note 3): DB package	0.6 W
DW package	1.6 W
PW package	0.7 W
Storage temperature range, $T_{stg}$	–65°C to 150°C

‡ Stresses beyond those listed under “absolute maximum ratings” may cause permanent damage to the device. These are stress ratings only, and functional operation of the device at these or any other conditions beyond those indicated under “recommended operating conditions” is not implied. Exposure to absolute-maximum-rated conditions for extended periods may affect device reliability.

- NOTES: 1. The input and output negative-voltage ratings may be exceeded if the input and output clamp-current ratings are observed.  
 2. This current flows only when the output is in the high state and  $V_O > V_{CC}$ .  
 3. The maximum package power dissipation is calculated using a junction temperature of 150°C and a board trace length of 750 mils. For more information, refer to the *Package Thermal Considerations* application note in the 1994 *ABT Advanced BiCMOS Technology Data Book*, literature number SCBD002B.

**SN54LVT573, SN74LVT573**  
**3.3-V ABT OCTAL TRANSPARENT D-TYPE LATCHES**  
**WITH 3-STATE OUTPUTS**

SCBS138D – MAY 1992 – REVISED JULY 1995

**recommended operating conditions (see Note 4)**

		SN54LVT573		SN74LVT573		UNIT
		MIN	MAX	MIN	MAX	
$V_{CC}$	Supply voltage	2.7	3.6	2.7	3.6	V
$V_{IH}$	High-level input voltage	2		2		V
$V_{IL}$	Low-level input voltage		0.8		0.8	V
$V_I$	Input voltage		5.5		5.5	V
$I_{OH}$	High-level output current		-24		-32	mA
$I_{OL}$	Low-level output current		48		64	mA
$\Delta t/\Delta v$	Input transition rise or fall rate	Outputs enabled		10	10	ns/V
$T_A$	Operating free-air temperature	-55	125	-40	85	°C

NOTE 4: Unused control inputs must be held high or low to prevent them from floating.

**勝特力材料 886-3-5753170**  
**勝特力电子(上海) 86-21-34970699**  
**勝特力电子(深圳) 86-755-83298787**  
[Http://www.100y.com.tw](http://www.100y.com.tw)



**SN54LVT573, SN74LVT573**  
**3.3-V ABT OCTAL TRANSPARENT D-TYPE LATCHES**  
**WITH 3-STATE OUTPUTS**

SCBS138D – MAY 1992 – REVISED JULY 1995

勝特力材料 886-3-5753170  
 勝特力电子(上海) 86-21-34970699  
 勝特力电子(深圳) 86-755-83298787  
[Http://www.100y.com.tw](http://www.100y.com.tw)

**electrical characteristics over recommended operating free-air temperature range (unless otherwise noted)**

PARAMETER	TEST CONDITIONS		SN54LVT573		SN74LVT573		UNIT
			MIN	TYP†	MAX	MIN	
$V_{IK}$	$V_{CC} = 2.7\text{ V}$ , $I_I = -18\text{ mA}$			-1.2		-1.2	V
$V_{OH}$	$V_{CC} = \text{MIN to MAX}^\ddagger$ , $I_{OH} = -100\ \mu\text{A}$		$V_{CC} - 0.2$		$V_{CC} - 0.2$		V
	$V_{CC} = 2.7\text{ V}$ , $I_{OH} = -8\text{ mA}$		2.4		2.4		
	$V_{CC} = 3\text{ V}$		2		2		
$V_{OL}$	$V_{CC} = 2.7\text{ V}$		$I_{OL} = 100\ \mu\text{A}$		0.2		V
			$I_{OL} = 24\text{ mA}$		0.5		
	$V_{CC} = 3\text{ V}$		$I_{OL} = 16\text{ mA}$		0.4		
			$I_{OL} = 32\text{ mA}$		0.5		
			$I_{OL} = 48\text{ mA}$		0.55		
			$I_{OL} = 64\text{ mA}$		0.55		
$I_I$	$V_{CC} = 0\text{ or MAX}^\ddagger$ , $V_I = 5.5\text{ V}$		50		10		$\mu\text{A}$
	$V_{CC} = 3.6\text{ V}$	$V_I = V_{CC}\text{ or GND}$	Control inputs		$\pm 1$		
		$V_I = V_{CC}$	Data inputs		1		
		$V_I = 0$			-5		
$I_{off}$	$V_{CC} = 0$ , $V_I\text{ or }V_O = 0\text{ to }4.5\text{ V}$				$\pm 100$		$\mu\text{A}$
$I_I(\text{hold})$	$V_{CC} = 3\text{ V}$		$V_I = 0.8\text{ V}$		75		$\mu\text{A}$
			$V_I = 2\text{ V}$		-75		
$I_{OZH}$	$V_{CC} = 3.6\text{ V}$ , $V_O = 3\text{ V}$		1		1		$\mu\text{A}$
$I_{OZL}$	$V_{CC} = 3.6\text{ V}$ , $V_O = 0.5\text{ V}$		-1		-1		$\mu\text{A}$
$I_{CC}$	$V_{CC} = 3.6\text{ V}$ , $V_I = V_{CC}\text{ or GND}$ , $I_O = 0$		Outputs high		0.13 0.39		mA
			Outputs low		8.6 14		
			Outputs disabled		0.13 0.39		
$\Delta I_{CC}^\S$	$V_{CC} = 3\text{ V to }3.6\text{ V}$ , One input at $V_{CC} - 0.6\text{ V}$ , Other inputs at $V_{CC}\text{ or GND}$		0.3		0.2		mA
$C_i$	$V_I = 3\text{ V or }0$		4		4		pF
$C_o$	$V_O = 3\text{ V or }0$		8		8		pF

† All typical values are at  $V_{CC} = 3.3\text{ V}$ ,  $T_A = 25^\circ\text{C}$ .

‡ For conditions shown as MIN or MAX, use the appropriate value specified under recommended operating conditions.

§ This is the increase in supply current for each input that is at the specified TTL voltage level rather than  $V_{CC}$  or GND.

**timing requirements over recommended operating free-air temperature range (unless otherwise noted) (see Figure 1)**

		SN54LVT573		SN74LVT573		UNIT		
		$V_{CC} = 3.3\text{ V} \pm 0.3\text{ V}$		$V_{CC} = 2.7\text{ V}$				
		MIN	MAX	MIN	MAX		MIN	MAX
$t_w$	Pulse duration, LE high	3.3		3.3		3.3	3.3	ns
$t_{su}$	Setup time, data before LE↓	1		0.9		0.7	0.6	ns
$t_h$	Hold time, data after LE↓	1.8		2		1.6	1.8	ns



POST OFFICE BOX 655303 • DALLAS, TEXAS 75265

**SN54LVT573, SN74LVT573**  
**3.3-V ABT OCTAL TRANSPARENT D-TYPE LATCHES**  
**WITH 3-STATE OUTPUTS**

SCBS138D – MAY 1992 – REVISED JULY 1995

switching characteristics over recommended operating free-air temperature range,  $C_L = 50$  pF (unless otherwise noted) (see Figure 1)

PARAMETER	FROM (INPUT)	TO (OUTPUT)	SN54LVT573				SN74LVT573				UNIT	
			$V_{CC} = 3.3\text{ V} \pm 0.3\text{ V}$		$V_{CC} = 2.7\text{ V}$		$V_{CC} = 3.3\text{ V} \pm 0.3\text{ V}$			$V_{CC} = 2.7\text{ V}$		
			MIN	MAX	MIN	MAX	MIN	TYP†	MAX	MIN		MAX
$t_{PLH}$	D	Q	0.5	4.7	4.9		1	2.5	4.2	4.7		ns
$t_{PHL}$			0.5	4.9	5.4		1	2.7	4.3	5.2		
$t_{PLH}$	LE	Q	1	6	6.9		1.6	3.5	5.6	6.3		ns
$t_{PHL}$			1.4	6.9	7.6		2.5	4.3	6.5	7.2		
$t_{PZH}$	$\overline{OE}$	Q	0.5	5.3	6.4		1	2.8	5.1	6.2		ns
$t_{PZL}$			0.7	5.7	7.2		1.3	3.3	5.5	6.6		
$t_{PHZ}$	$\overline{OE}$	Q	1.2	5.9	6.9		2	3.7	5.7	6.7		ns
$t_{PLZ}$			1	5.4	5.5		1.5	3	4.6	5.1		

† All typical values are at  $V_{CC} = 3.3\text{ V}$ ,  $T_A = 25^\circ\text{C}$ .

勝特力材料 886-3-5753170  
 勝特力电子(上海) 86-21-34970699  
 勝特力电子(深圳) 86-755-83298787  
[Http://www.100y.com.tw](http://www.100y.com.tw)

# SN54LVT573, SN74LVT573 3.3-V ABT OCTAL TRANSPARENT D-TYPE LATCHES WITH 3-STATE OUTPUTS

SCBS138D – MAY 1992 – REVISED JULY 1995

## PARAMETER MEASUREMENT INFORMATION

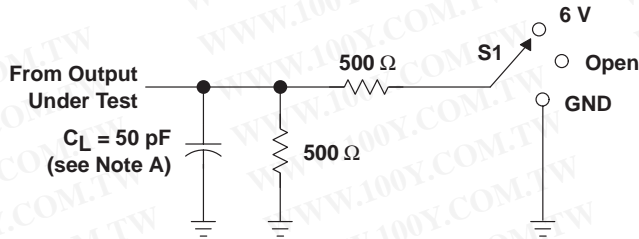

TEST	S1
$t_{PLH}/t_{PHL}$	Open
$t_{PLZ}/t_{PZL}$	6 V
$t_{PHZ}/t_{PZH}$	GND

LOAD CIRCUIT FOR OUTPUTS

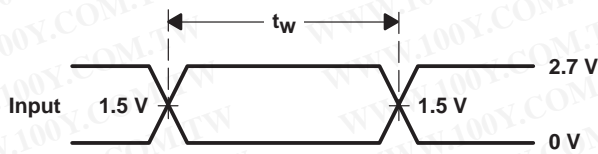

VOLTAGE WAVEFORMS  
PULSE DURATION

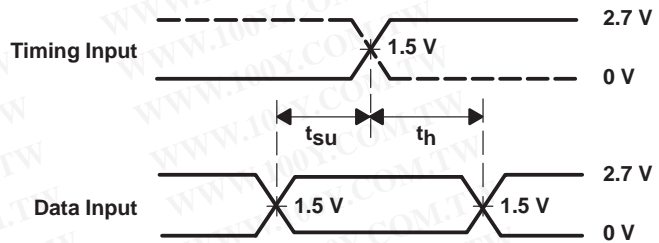

VOLTAGE WAVEFORMS  
SETUP AND HOLD TIMES

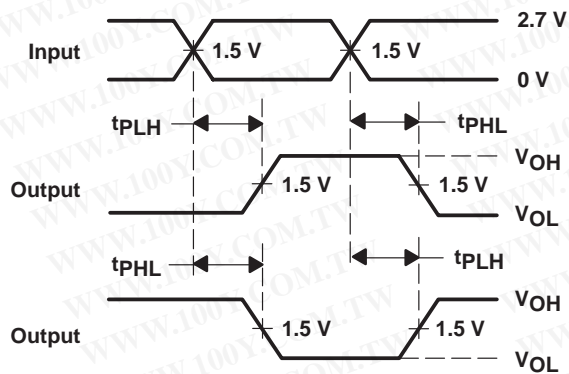

VOLTAGE WAVEFORMS  
PROPAGATION DELAY TIMES  
INVERTING AND NONINVERTING OUTPUTS

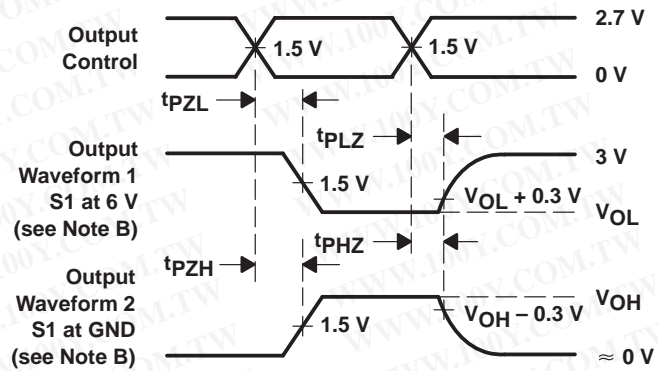

VOLTAGE WAVEFORMS  
ENABLE AND DISABLE TIMES  
LOW- AND HIGH-LEVEL ENABLING

- NOTES: A.  $C_L$  includes probe and jig capacitance.  
 B. Waveform 1 is for an output with internal conditions such that the output is low except when disabled by the output control. Waveform 2 is for an output with internal conditions such that the output is high except when disabled by the output control.  
 C. All input pulses are supplied by generators having the following characteristics:  $PRR \leq 10$  MHz,  $Z_O = 50 \Omega$ ,  $t_r \leq 2.5$  ns,  $t_f \leq 2.5$  ns.  
 D. The outputs are measured one at a time with one transition per measurement.

Figure 1. Load Circuit and Voltage Waveforms

勝特力材料 886-3-5753170  
 勝特力电子(上海) 86-21-34970699  
 勝特力电子(深圳) 86-755-83298787  
[Http://www.100y.com.tw](http://www.100y.com.tw)

**PACKAGING INFORMATION**

Orderable Device	Status <sup>(1)</sup>	Package Type	Package Drawing	Pins	Package Qty	Eco Plan <sup>(2)</sup>	Lead/Ball Finish	MSL Peak Temp <sup>(3)</sup>
SN74LVT573DBLE	OBSOLETE	SSOP	DB	20		TBD	Call TI	Call TI
SN74LVT573DBR	NRND	SSOP	DB	20	2000	Green (RoHS & no Sb/Br)	CU NIPDAU	Level-1-260C-UNLIM
SN74LVT573DW	NRND	SOIC	DW	20	25	Green (RoHS & no Sb/Br)	CU NIPDAU	Level-1-260C-UNLIM
SN74LVT573DWR	NRND	SOIC	DW	20	2000	Green (RoHS & no Sb/Br)	CU NIPDAU	Level-1-260C-UNLIM
SN74LVT573NSR	OBSOLETE	SO	NS	20		TBD	Call TI	Call TI
SN74LVT573PWLE	OBSOLETE	TSSOP	PW	20		TBD	Call TI	Call TI
SN74LVT573PWR	NRND	TSSOP	PW	20	2000	Green (RoHS & no Sb/Br)	CU NIPDAU	Level-1-260C-UNLIM
SNJ54LVT573FK	OBSOLETE	LCCC	FK	20		TBD	Call TI	Call TI
SNJ54LVT573J	OBSOLETE	CDIP	J	20		TBD	Call TI	Call TI
SNJ54LVT573W	OBSOLETE	CFP	W	20		TBD	Call TI	Call TI

<sup>(1)</sup> The marketing status values are defined as follows:

**ACTIVE:** Product device recommended for new designs.

**LIFEBUY:** TI has announced that the device will be discontinued, and a lifetime-buy period is in effect.

**NRND:** Not recommended for new designs. Device is in production to support existing customers, but TI does not recommend using this part in a new design.

**PREVIEW:** Device has been announced but is not in production. Samples may or may not be available.

**OBSOLETE:** TI has discontinued the production of the device.

<sup>(2)</sup> Eco Plan - The planned eco-friendly classification: Pb-Free (RoHS), Pb-Free (RoHS Exempt), or Green (RoHS & no Sb/Br) - please check for the latest availability information and additional product content details.

**TBD:** The Pb-Free/Green conversion plan has not been defined.

**Pb-Free (RoHS):** TI's terms "Lead-Free" or "Pb-Free" mean semiconductor products that are compatible with the current RoHS requirements for all 6 substances, including the requirement that lead not exceed 0.1% by weight in homogeneous materials. Where designed to be soldered at high temperatures, TI Pb-Free products are suitable for use in specified lead-free processes.

**Pb-Free (RoHS Exempt):** This component has a RoHS exemption for either 1) lead-based flip-chip solder bumps used between the die and package, or 2) lead-based die adhesive used between the die and leadframe. The component is otherwise considered Pb-Free (RoHS compatible) as defined above.

**Green (RoHS & no Sb/Br):** TI defines "Green" to mean Pb-Free (RoHS compatible), and free of Bromine (Br) and Antimony (Sb) based flame retardants (Br or Sb do not exceed 0.1% by weight in homogeneous material)

<sup>(3)</sup> MSL, Peak Temp. -- The Moisture Sensitivity Level rating according to the JEDEC industry standard classifications, and peak solder temperature.

**Important Information and Disclaimer:** The information provided on this page represents TI's knowledge and belief as of the date that it is provided. TI bases its knowledge and belief on information provided by third parties, and makes no representation or warranty as to the accuracy of such information. Efforts are underway to better integrate information from third parties. TI has taken and continues to take reasonable steps to provide representative and accurate information but may not have conducted destructive testing or chemical analysis on incoming materials and chemicals. TI and TI suppliers consider certain information to be proprietary, and thus CAS numbers and other limited information may not be available for release.

In no event shall TI's liability arising out of such information exceed the total purchase price of the TI part(s) at issue in this document sold by TI to Customer on an annual basis.

勝特力材料 886-3-5753170  
 勝特力电子(上海) 86-21-34970699  
 勝特力电子(深圳) 86-755-83298787  
[Http://www.100y.com.tw](http://www.100y.com.tw)



**TAPE AND REEL INFORMATION**

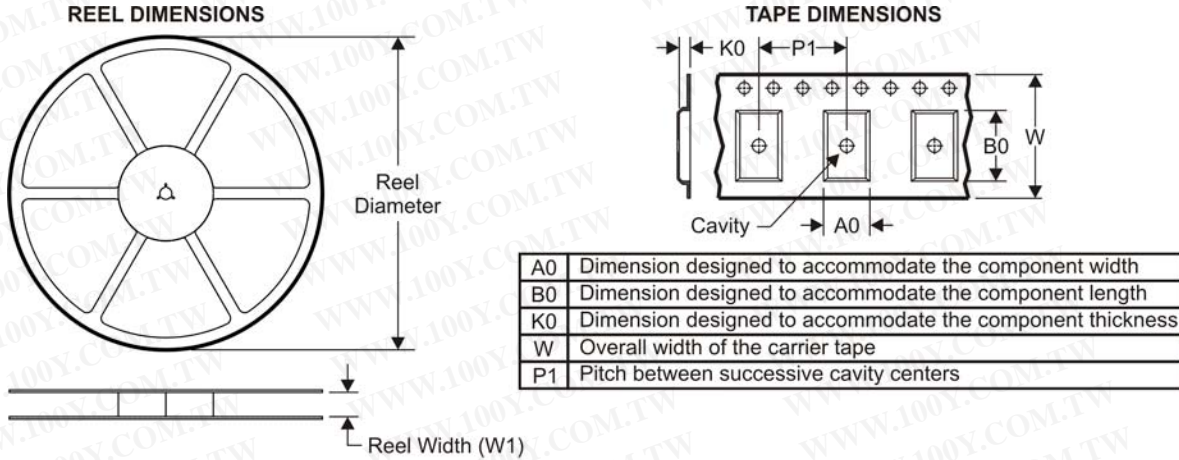

**QUADRANT ASSIGNMENTS FOR PIN 1 ORIENTATION IN TAPE**

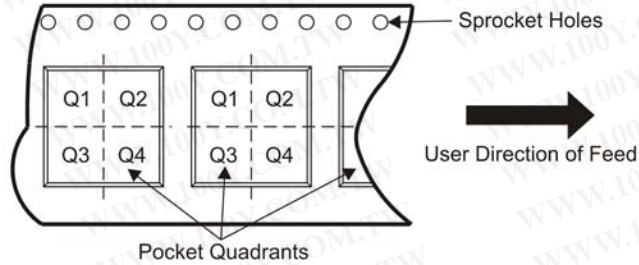

\*All dimensions are nominal

Device	Package Type	Package Drawing	Pins	SPQ	Reel Diameter (mm)	Reel Width W1 (mm)	A0 (mm)	B0 (mm)	K0 (mm)	P1 (mm)	W (mm)	Pin1 Quadrant
SN74LVT573DBR	SSOP	DB	20	2000	330.0	16.4	8.2	7.5	2.5	12.0	16.0	Q1
SN74LVT573DWR	SOIC	DW	20	2000	330.0	24.4	10.8	13.0	2.7	12.0	24.0	Q1
SN74LVT573PWR	TSSOP	PW	20	2000	330.0	16.4	6.95	7.1	1.6	8.0	16.0	Q1

勝特力材料 886-3-5753170  
 勝特力电子(上海) 86-21-34970699  
 勝特力电子(深圳) 86-755-83298787  
[Http://www.100y.com.tw](http://www.100y.com.tw)



**TAPE AND REEL BOX DIMENSIONS**

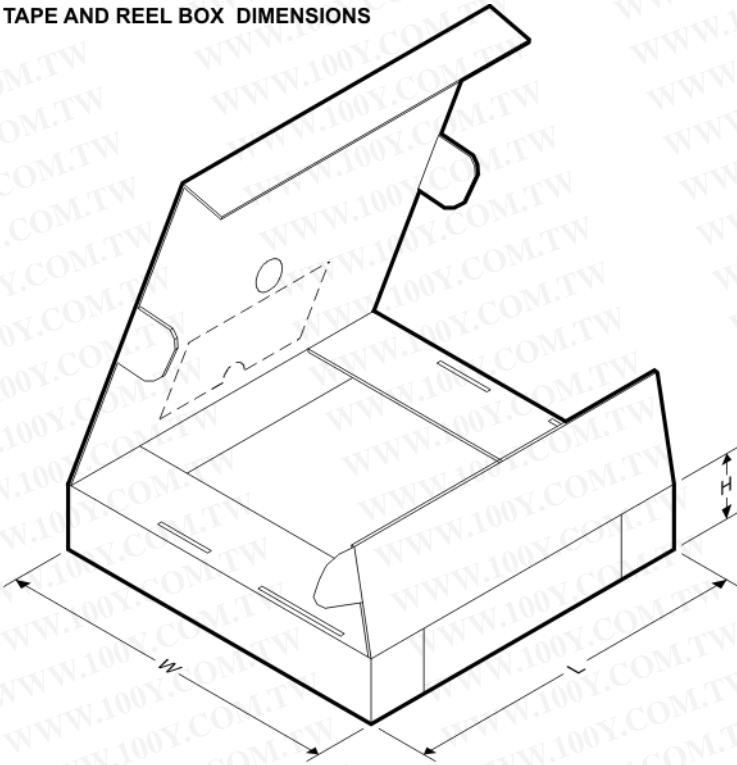

\*All dimensions are nominal

Device	Package Type	Package Drawing	Pins	SPQ	Length (mm)	Width (mm)	Height (mm)
SN74LVT573DBR	SSOP	DB	20	2000	346.0	346.0	33.0
SN74LVT573DWR	SOIC	DW	20	2000	346.0	346.0	41.0
SN74LVT573PWR	TSSOP	PW	20	2000	346.0	346.0	33.0

勝特力材料 886-3-5753170  
 勝特力电子(上海) 86-21-34970699  
 勝特力电子(深圳) 86-755-83298787  
[Http://www.100y.com.tw](http://www.100y.com.tw)

DB (R-PDSO-G\*\*)

PLASTIC SMALL-OUTLINE

28 PINS SHOWN

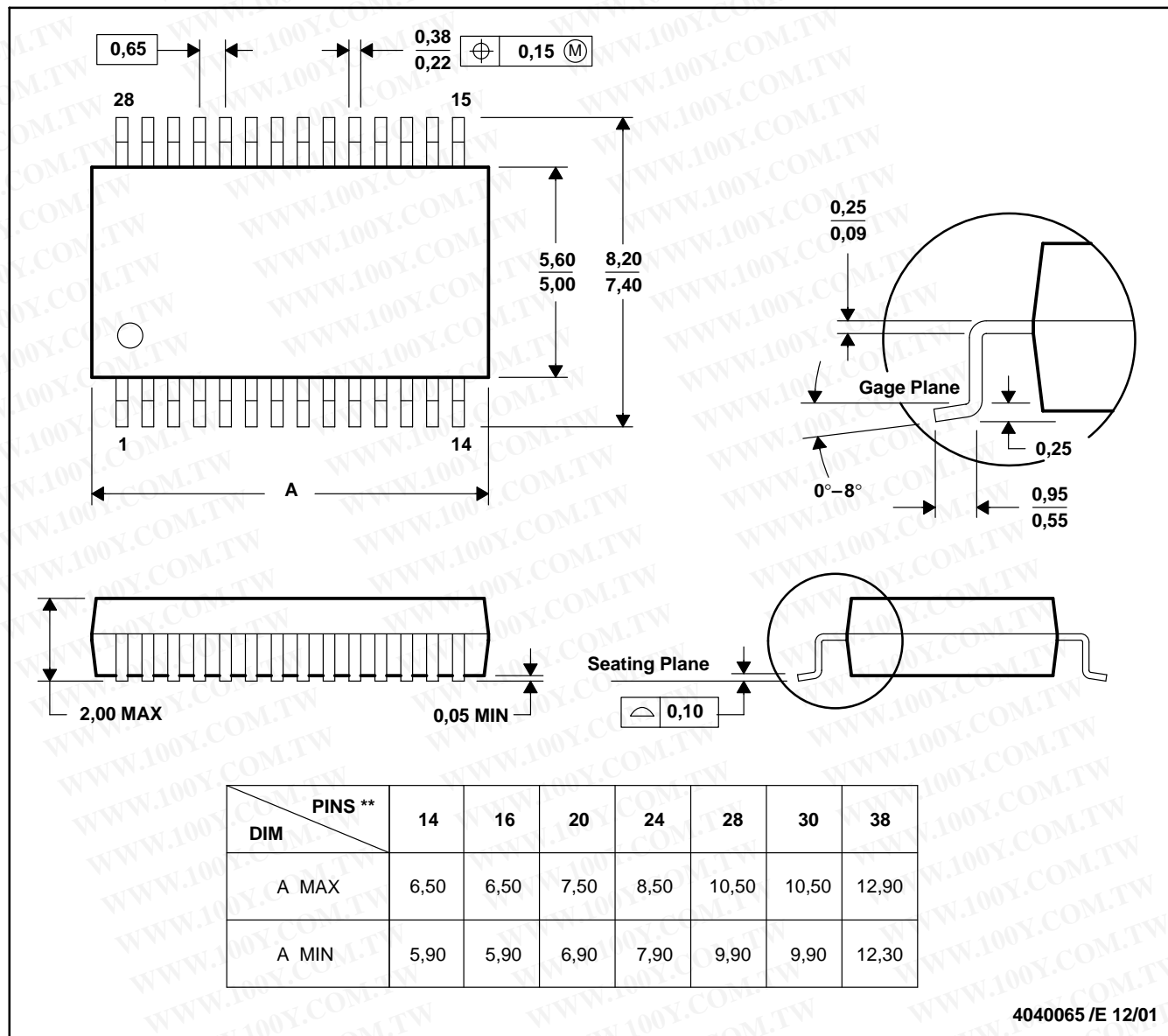

- NOTES: A. All linear dimensions are in millimeters.  
 B. This drawing is subject to change without notice.  
 C. Body dimensions do not include mold flash or protrusion not to exceed 0,15.  
 D. Falls within JEDEC MO-150

勝特力材料 886-3-5753170  
 勝特力电子(上海) 86-21-34970699  
 勝特力电子(深圳) 86-755-83298787  
[Http://www.100y.com.tw](http://www.100y.com.tw)

PW (R-PDSO-G\*\*)

PLASTIC SMALL-OUTLINE PACKAGE

14 PINS SHOWN

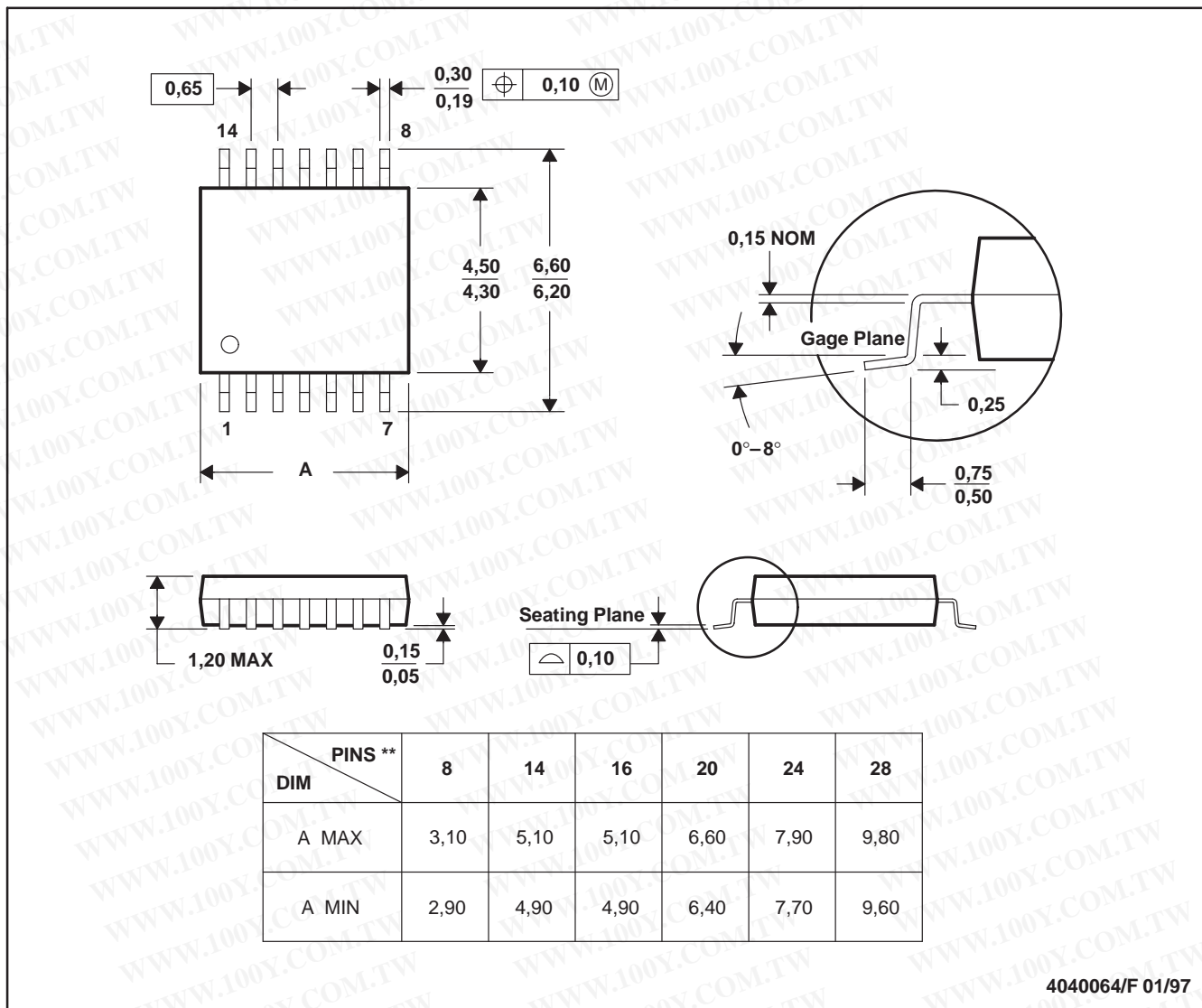

- NOTES: A. All linear dimensions are in millimeters.  
 B. This drawing is subject to change without notice.  
 C. Body dimensions do not include mold flash or protrusion not to exceed 0,15.  
 D. Falls within JEDEC MO-153

勝特力材料 886-3-5753170  
 胜特力电子(上海) 86-21-34970699  
 胜特力电子(深圳) 86-755-83298787  
[Http://www.100y.com.tw](http://www.100y.com.tw)

# MECHANICAL DATA

NS (R-PDSO-G\*\*)

PLASTIC SMALL-OUTLINE PACKAGE

14-PINS SHOWN

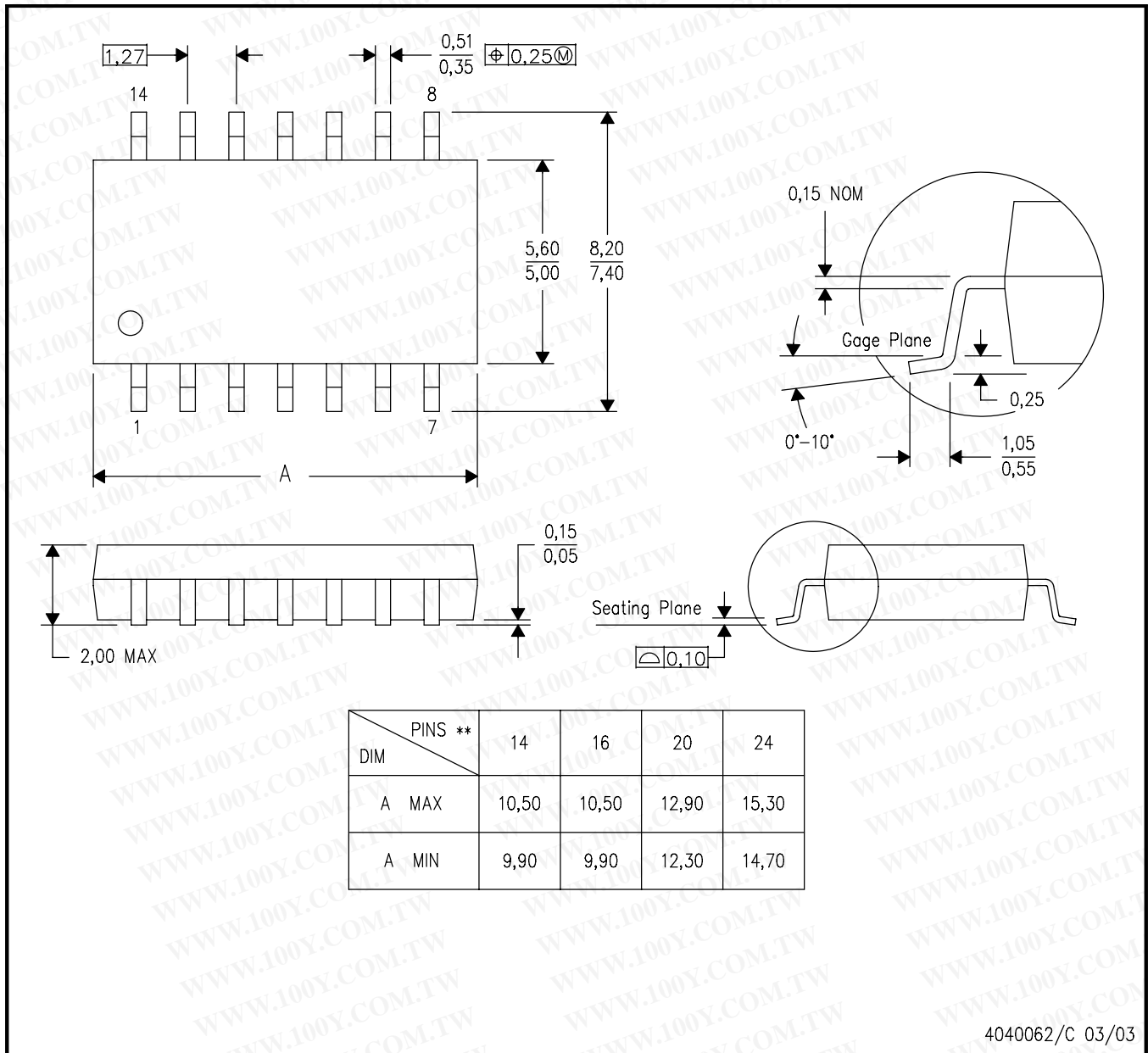

- NOTES:
- A. All linear dimensions are in millimeters.
  - B. This drawing is subject to change without notice.
  - C. Body dimensions do not include mold flash or protrusion, not to exceed 0,15.

**勝特力材料 886-3-5753170**  
**勝特力电子(上海) 86-21-34970699**  
**勝特力电子(深圳) 86-755-83298787**  
[Http://www.100y.com.tw](http://www.100y.com.tw)



J (R-GDIP-T\*\*)  
 14 LEADS SHOWN

CERAMIC DUAL IN-LINE PACKAGE

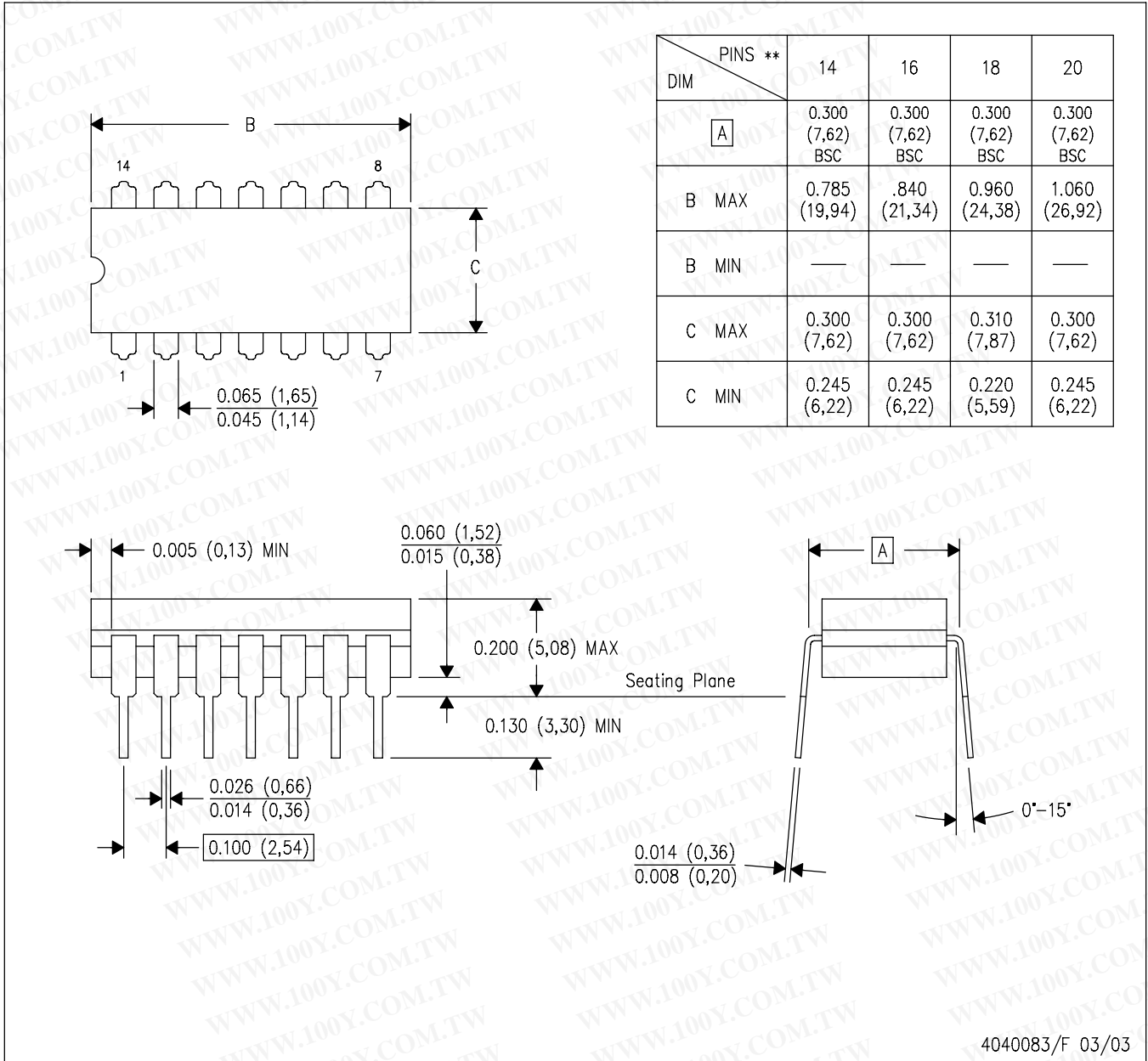

- NOTES:
- A. All linear dimensions are in inches (millimeters).
  - B. This drawing is subject to change without notice.
  - C. This package is hermetically sealed with a ceramic lid using glass frit.
  - D. Index point is provided on cap for terminal identification only on press ceramic glass frit seal only.
  - E. Falls within MIL STD 1835 GDIP1-T14, GDIP1-T16, GDIP1-T18 and GDIP1-T20.

FK (S-CQCC-N\*\*)

LEADLESS CERAMIC CHIP CARRIER

28 TERMINAL SHOWN

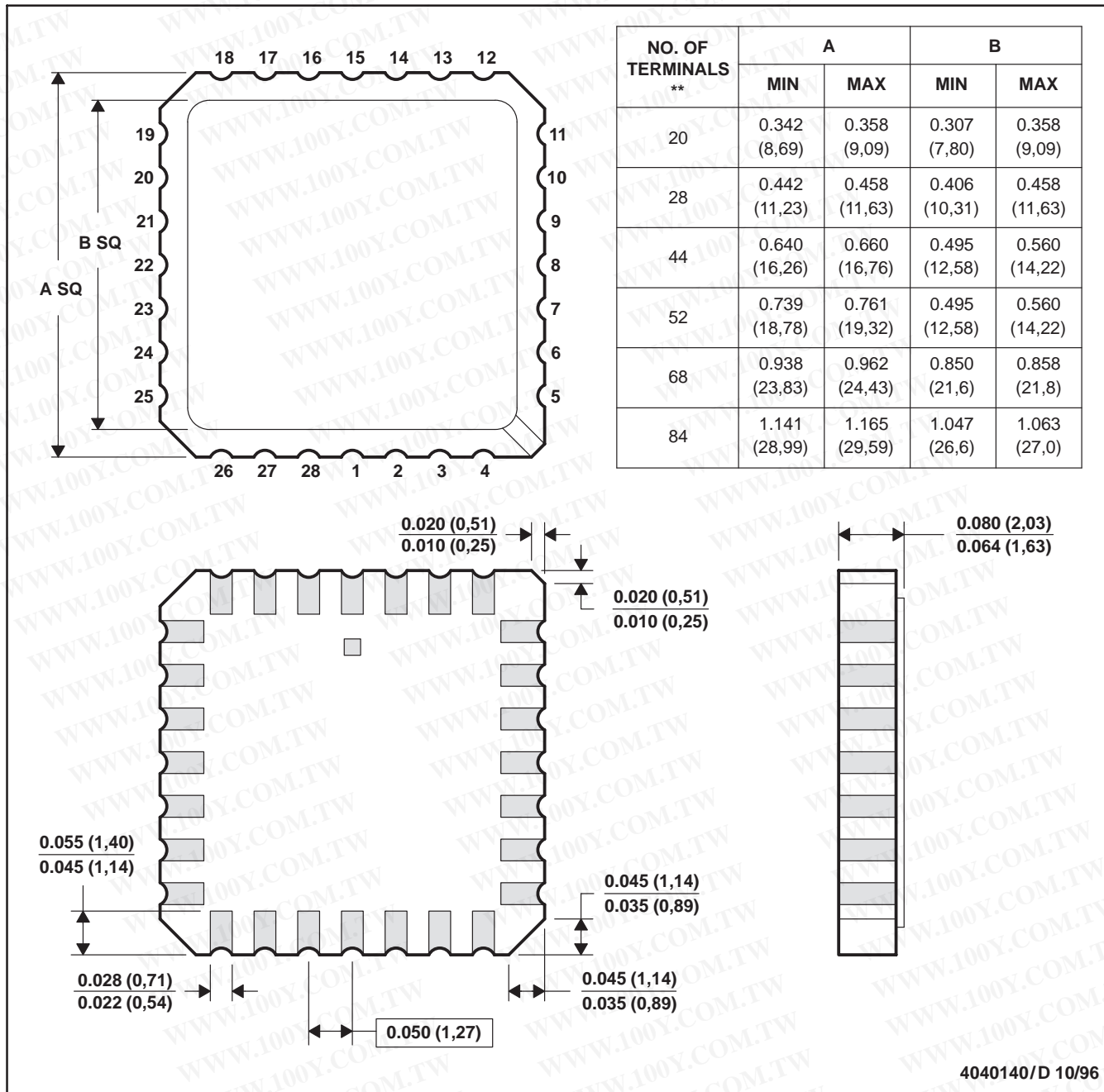

- NOTES:
- A. All linear dimensions are in inches (millimeters).
  - B. This drawing is subject to change without notice.
  - C. This package can be hermetically sealed with a metal lid.
  - D. The terminals are gold plated.
  - E. Falls within JEDEC MS-004

勝特力材料 886-3-5753170  
 勝特力电子(上海) 86-21-34970699  
 勝特力电子(深圳) 86-755-83298787  
[Http://www.100y.com.tw](http://www.100y.com.tw)

W (R-GDFP-F20)

CERAMIC DUAL FLATPACK

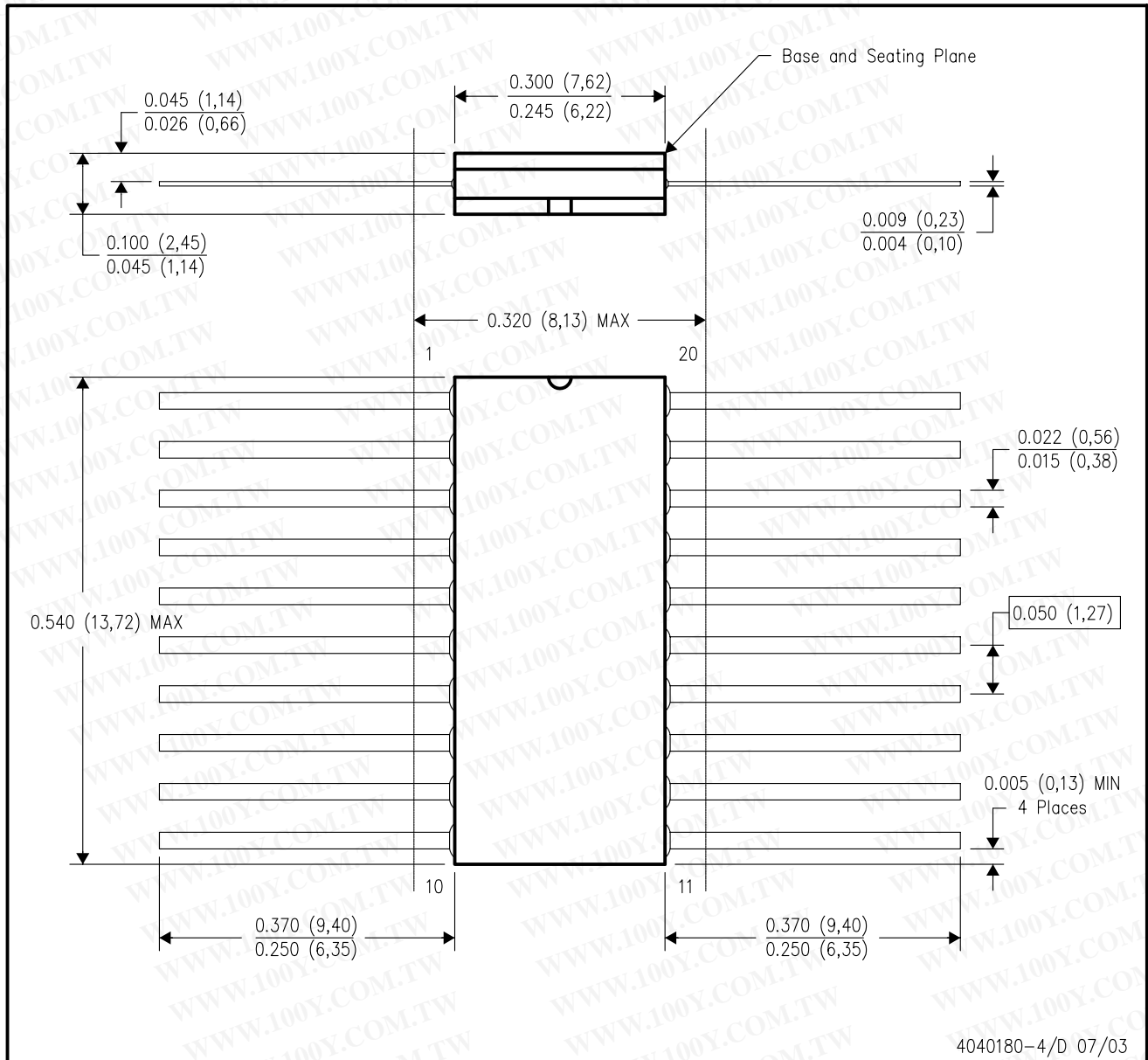

- NOTES:
- A. All linear dimensions are in inches (millimeters).
  - B. This drawing is subject to change without notice.
  - C. This package can be hermetically sealed with a ceramic lid using glass frit.
  - D. Index point is provided on cap for terminal identification only.
  - E. Falls within Mil-Std 1835 GDFP2-F20

勝特力材料 886-3-5753170  
 勝特力电子(上海) 86-21-34970699  
 勝特力电子(深圳) 86-755-83298787  
[Http://www.100y.com.tw](http://www.100y.com.tw)

DW (R-PDSO-G20)

PLASTIC SMALL-OUTLINE PACKAGE

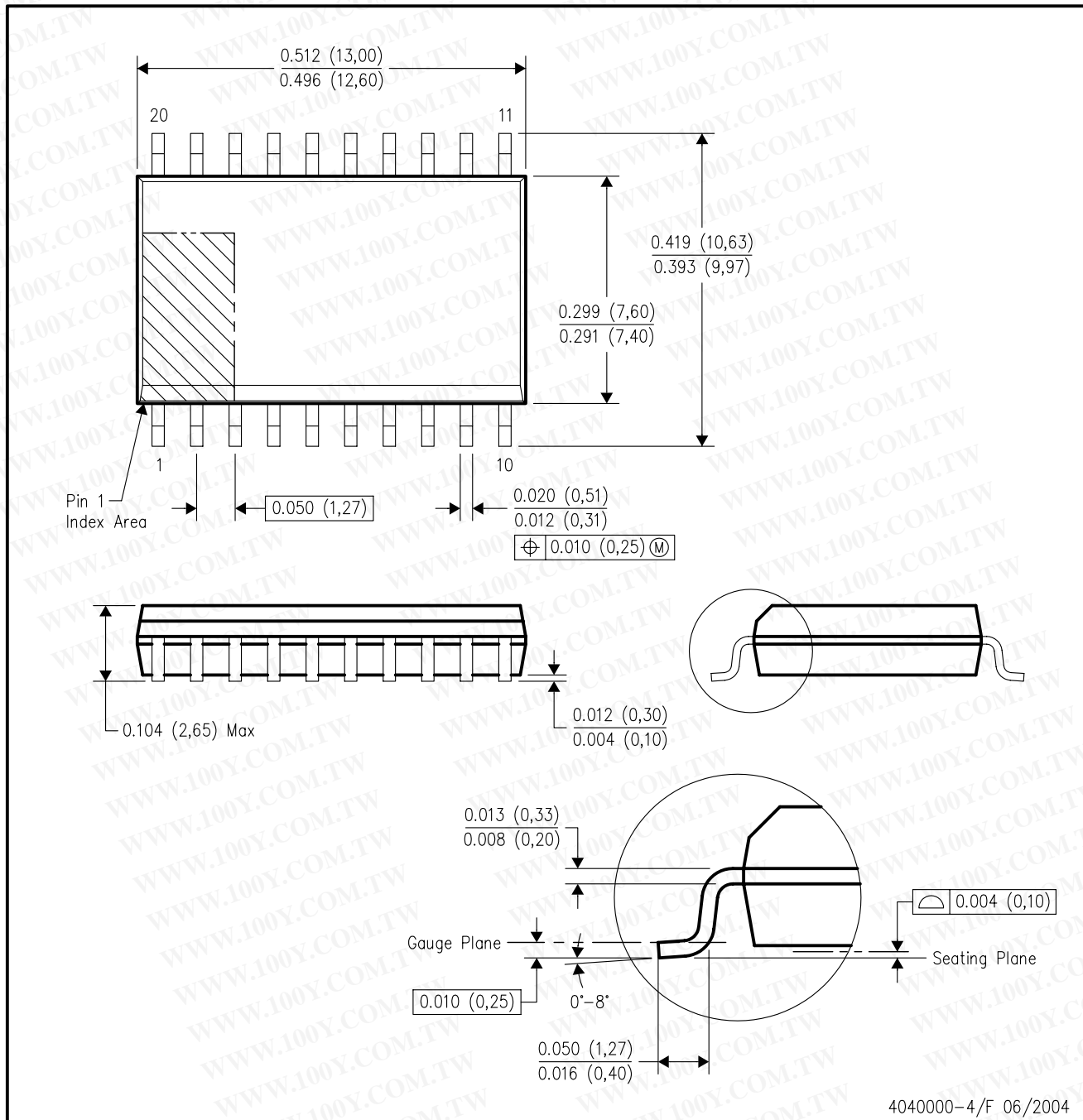

- NOTES:
- A. All linear dimensions are in inches (millimeters).
  - B. This drawing is subject to change without notice.
  - C. Body dimensions do not include mold flash or protrusion not to exceed 0.006 (0,15).
  - D. Falls within JEDEC MS-013 variation AC.