

FEATURES

- Member of the Texas Instruments Widebus™ Family
- Max t_{pd} of 5.8 ns at 3.3 V
- ± 24 -mA Output Drive at 3.3 V
- Control Inputs V_{IH}/V_{IL} Levels Are Referenced to V_{CCA} Voltage
- Latch-Up Performance Exceeds 250 mA Per JESD 17

NOTE: New and improved versions of the SN74ALVC164245 are available. The new part numbers are SN74LVC16T245 and SN74LVCH16T245 and should be considered for new designs.

DESCRIPTION/ORDERING INFORMATION

This 16-bit (dual-octal) noninverting bus transceiver contains two separate supply rails. B port has V_{CCB} , which is set to operate at 3.3 V and 5 V. A port has V_{CCA} , which is set to operate at 2.5 V and 3.3 V. This allows for translation from a 2.5-V to a 3.3-V environment, and vice versa, or from a 3.3-V to a 5-V environment, and vice versa.

The SN74ALVC164245 is designed for asynchronous communication between data buses. The control circuitry (1DIR, 2DIR, $1\overline{OE}$, and $2\overline{OE}$) is powered by V_{CCA} .

To ensure the high-impedance state during power up or power down, the output-enable (\overline{OE}) input should be tied to V_{CC} through a pullup resistor; the minimum value of the resistor is determined by the current-sinking capability of the driver.

DGG OR DL PACKAGE
(TOP VIEW)

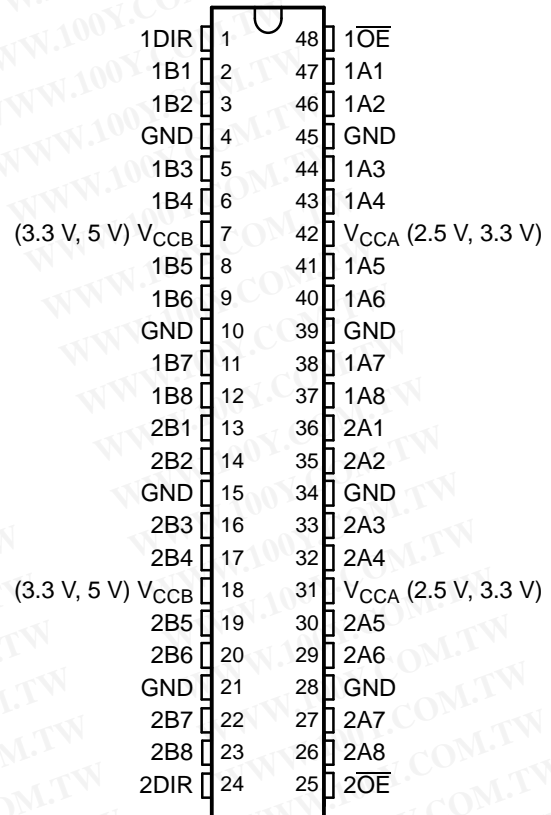

ORDERING INFORMATION

T_A	PACKAGE ⁽¹⁾		ORDERABLE PART NUMBER	TOP-SIDE MARKING
-40°C to 85°C	FBGA – GRD	Tape and reel	74ALVC164245GRDR	VC4245
	FBGA – ZRD (Pb-free)		74ALVC164245ZRDR	
	SSOP – DL	Tube of 25	SN74ALVC164245DL	ALVC164245
		Reel of 1000	SN74ALVC164245DLR 74ALVC164245DLRG4	
	TSSOP – DGG	Reel of 2000	SN74ALVC164245DGGR	ALVC164245
			74ALVC164245DGGRG4	
		Reel of 250	SN74ALVC164245DGGT	
			74ALVC164245DGGTE4	
	VFBGA – GQL	Reel of 1000	SN74ALVC164245KR	VC4245
	VFBGA – ZQL (Pb-free)		74ALVC164245ZQLR	

(1) Package drawings, standard packing quantities, thermal data, symbolization, and PCB design guidelines are available at www.ti.com/sc/package.



Please be aware that an important notice concerning availability, standard warranty, and use in critical applications of Texas Instruments semiconductor products and disclaimers thereto appears at the end of this data sheet.

Widebus is a trademark of Texas Instruments.

SN74ALVC164245
16-BIT 2.5-V TO 3.3-V/3.3-V TO 5-V LEVEL-SHIFTING TRANSCEIVER
WITH 3-STATE OUTPUTS

SCAS416P—MARCH 1994—REVISED NOVEMBER 2005

DESCRIPTION/ORDERING INFORMATION (CONTINUED)

The logic levels of the direction-control (DIR) input and the output-enable (\overline{OE}) input activate either the B-port outputs or the A-port outputs or place both output ports into the high-impedance mode. The device transmits data from the A bus to the B bus when the B-port outputs are activated, and from the B bus to the A bus when the A-port outputs are activated. The input circuitry on both A and B ports always is active and must have a logic HIGH or LOW level applied to prevent excess I_{CC} and I_{CCZ} .

GQL OR ZQL PACKAGE
(TOP VIEW)

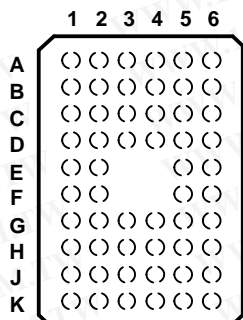

TERMINAL ASSIGNMENTS⁽¹⁾
(56-Ball GQL/ZQL Package)

	1	2	3	4	5	6
A	1DIR	NC	NC	NC	NC	1 \overline{OE}
B	1B2	1B1	GND	GND	1A1	1A2
C	1B4	1B3	V _{CCB}	V _{CCA}	1A3	1A4
D	1B6	1B5	GND	GND	1A5	1A6
E	1B8	1B7			1A7	1A8
F	2B1	2B2			2A2	2A1
G	2B3	2B4	GND	GND	2A4	2A3
H	2B5	2B6	V _{CCB}	V _{CCA}	2A6	2A5
J	2B7	2B8	GND	GND	2A8	2A7
K	2DIR	NC	NC	NC	NC	2 \overline{OE}

(1) NC – No internal connection

TERMINAL ASSIGNMENTS⁽¹⁾
(54-Ball GRD/ZRD Package)

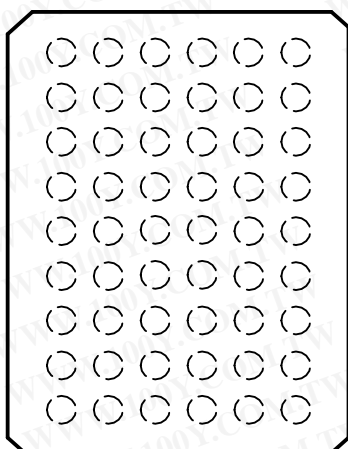

	1	2	3	4	5	6
A	1B1	NC	1DIR	1 \overline{OE}	NC	1A1
B	1B3	1B2	NC	NC	1A2	1A3
C	1B5	1B4	V _{CCB}	V _{CCA}	1A4	1A5
D	1B7	1B6	GND	GND	1A6	1A7
E	2B1	1B8	GND	GND	1A8	2A1
F	2B3	2B2	GND	GND	2A2	2A3
G	2B5	2B4	V _{CCB}	V _{CCA}	2A4	2A5
H	2B7	2B6	NC	NC	2A6	2A7
J	2B8	NC	2DIR	2 \overline{OE}	NC	2A8

(1) NC – No internal connection

FUNCTION TABLE⁽¹⁾
(EACH 8-BIT SECTION)

CONTROL INPUTS		OUTPUT CIRCUITS		OPERATION
\overline{OE}	DIR	A PORT	B PORT	
L	L	Enabled	Hi-Z	B data to A bus
L	H	Hi-Z	Enabled	A data to B bus
H	X	Hi-Z	Hi-Z	Isolation

(1) Input circuits of the data I/Os always are active.

勝特力材料 886-3-5753170
 勝特力电子(上海) 86-21-54151736
 勝特力电子(深圳) 86-755-83298787
[Http://www.100y.com.tw](http://www.100y.com.tw)

LOGIC DIAGRAM (POSITIVE LOGIC)

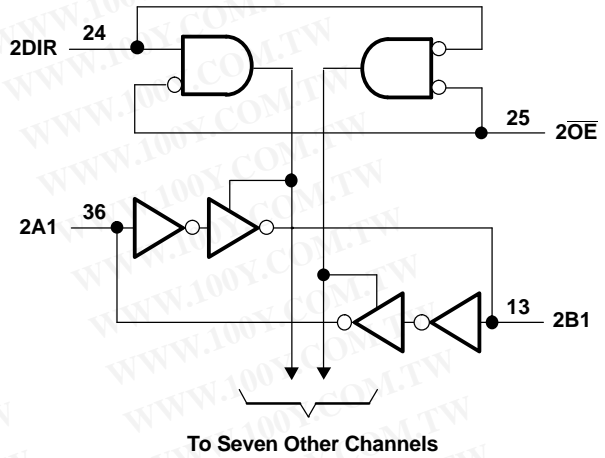
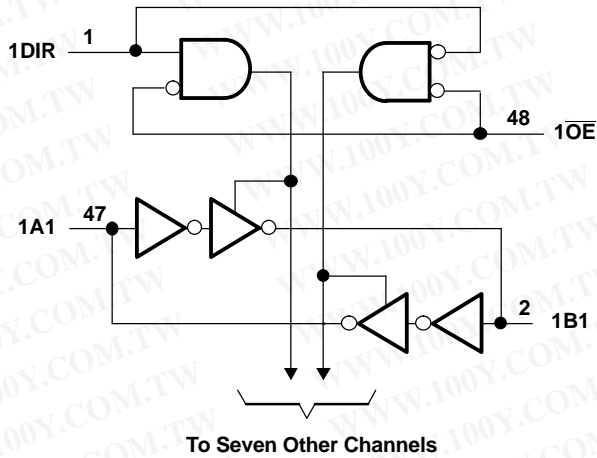

Absolute Maximum Ratings⁽¹⁾

over operating free-air temperature range for V_{CCB} at 5 V and V_{CCA} at 3.3 V (unless otherwise noted)

		MIN	MAX	UNIT	
V_{CC}	Supply voltage range	V_{CCA}	-0.5	4.6	V
		V_{CCB}	-0.5	6	
V_I	Input voltage range	Except I/O ports ⁽²⁾	-0.5	6	V
		I/O port A ⁽³⁾	-0.5	$V_{CCA} + 0.5$	
		I/O port B ⁽²⁾	-0.5	$V_{CCB} + 0.5$	
I_{IK}	Input clamp current	$V_I < 0$		-50	mA
I_{OK}	Output clamp current	$V_O < 0$		-50	mA
I_O	Continuous output current			± 50	mA
		Continuous current through each V_{CC} or GND			
θ_{JA}	Package thermal impedance ⁽⁴⁾	DGG package		70	°C/W
		DL package		63	
		GQL/ZQL package		42	
		GRD/ZRD package		36	
T_{stg}	Storage temperature range		-65	150	°C

- (1) Stresses beyond those listed under "absolute maximum ratings" may cause permanent damage to the device. These are stress ratings only, and functional operation of the device at these or any other conditions beyond those indicated under "recommended operating conditions" is not implied. Exposure to absolute-maximum-rated conditions for extended periods may affect device reliability.
- (2) This value is limited to 6 V maximum.
- (3) This value is limited to 4.6 V maximum.
- (4) The package thermal impedance is calculated in accordance with JESD 51-7.

勝特力材料 886-3-5753170
 勝特力电子(上海) 86-21-54151736
 勝特力电子(深圳) 86-755-83298787
[Http://www.100y.com.tw](http://www.100y.com.tw)

SN74ALVC164245

16-BIT 2.5-V TO 3.3-V/3.3-V TO 5-V LEVEL-SHIFTING TRANSCEIVER WITH 3-STATE OUTPUTS

SCAS416P–MARCH 1994–REVISED NOVEMBER 2005

Recommended Operating Conditions⁽¹⁾

for V_{CCB} at 3.3 V and 5 V

		MIN	MAX	UNIT
V_{CCB}	Supply voltage	3	5.5	V
V_{IH}	High-level input voltage	2		V
V_{IL}	Low-level input voltage	$V_{CCB} = 3 \text{ V to } 3.6 \text{ V}$		V
		$V_{CCB} = 4.5 \text{ V to } 5.5 \text{ V}$		
V_{IB}	Input voltage	0	V_{CCB}	V
V_{OB}	Output voltage	0	V_{CCB}	V
I_{OH}	High-level output current		-24	mA
I_{OL}	Low-level output current		24	mA
$\Delta t/\Delta v$	Input transition rise or fall rate		10	ns/V
T_A	Operating free-air temperature	-40	85	°C

(1) All unused inputs of the device must be held at V_{CC} or GND to ensure proper device operation. Refer to the TI application report, *Implications of Slow or Floating CMOS Inputs*, literature number SCBA004.

Recommended Operating Conditions⁽¹⁾

for V_{CCA} at 2.5 V and 3.3 V

		MIN	MAX	UNIT
V_{CCA}	Supply voltage	2.3	3.6	V
V_{IH}	High-level input voltage	$V_{CCA} = 2.3 \text{ V to } 2.7 \text{ V}$		V
		$V_{CCA} = 3 \text{ V to } 3.6 \text{ V}$		
V_{IL}	Low-level input voltage	$V_{CCA} = 2.3 \text{ V to } 2.7 \text{ V}$		V
		$V_{CCA} = 3 \text{ V to } 3.6 \text{ V}$		
V_{IA}	Input voltage	0	V_{CCA}	V
V_{OA}	Output voltage	0	V_{CCA}	V
I_{OH}	High-level output current	$V_{CCA} = 2.3 \text{ V}$		mA
		$V_{CCA} = 3 \text{ V}$		
I_{OL}	Low-level output current	$V_{CCA} = 2.3 \text{ V}$		mA
		$V_{CCA} = 3 \text{ V}$		
$\Delta t/\Delta v$	Input transition rise or fall rate		10	ns/V
T_A	Operating free-air temperature	-40	85	°C

(1) All unused inputs of the device must be held at V_{CC} or GND to ensure proper device operation. Refer to the TI application report, *Implications of Slow or Floating CMOS Inputs*, literature number SCBA004.

勝特力材料 886-3-5753170
 勝特力电子(上海) 86-21-54151736
 勝特力电子(深圳) 86-755-83298787
[Http://www.100y.com.tw](http://www.100y.com.tw)

Electrical Characteristics

over recommended operating free-air temperature range for $V_{CCA} = 2.7\text{ V}$ to 3.6 V and $V_{CCB} = 4.5\text{ V}$ to 5.5 V (unless otherwise noted)

PARAMETER	TEST CONDITIONS	V_{CCA}	V_{CCB}	MIN	TYP ⁽¹⁾	MAX	UNIT
V_{OH}	B to A	$I_{OH} = -100\ \mu\text{A}$	2.7 V to 3.6 V		$V_{CC} - 0.2$		V
		$I_{OH} = -12\ \text{mA}$	2.7 V		2.2		
		$I_{OH} = -24\ \text{mA}$	3 V		2.4		
	A to B	$I_{OH} = -100\ \mu\text{A}$		4.5 V	4.3		
				5.5 V	5.3		
		$I_{OH} = -24\ \text{mA}$		4.5 V	3.7		
			5.5 V	4.7			
V_{OL}	B to A	$I_{OL} = 100\ \mu\text{A}$	2.7 V to 3.6 V			0.2	V
		$I_{OL} = 12\ \text{mA}$	2.7 V			0.4	
		$I_{OL} = 24\ \text{mA}$	3 V			0.55	
	A to B	$I_{OL} = 100\ \mu\text{A}$		4.5 V to 5.5 V		0.2	
		$I_{OL} = 12\ \text{mA}$		4.5 V to 5.5 V		0.55	
		$I_{OL} = 24\ \text{mA}$		4.5 V to 5.5 V		0.55	
I_I	Control inputs	$V_I = V_{CCA}/V_{CCB}$ or GND	3.6 V	5.5 V		±5	μA
$I_{OZ}^{(2)}$	A or B port	$V_O = V_{CCA}/V_{CCB}$ or GND	3.6 V	5.5 V		±10	μA
I_{CC}		$V_I = V_{CCA}/V_{CCB}$ or GND, $I_O = 0$	3.6 V	5.5 V		40	μA
$\Delta I_{CC}^{(3)}$		One input at $V_{CCA}/V_{CCB} - 0.6\text{ V}$, Other inputs at V_{CCA}/V_{CCB} or GND	3 V to 3.6 V	4.5 V to 5.5 V		750	μA
C_i	Control inputs	$V_I = V_{CCA}/V_{CCB}$ or GND	3.3 V	5 V		6.5	pF
C_{io}	A or B port	$V_O = V_{CCA}/V_{CCB}$ or GND	3.3 V	3.3 V		8.5	pF

(1) Typical values are measured at $V_{CCA} = 3.3\text{ V}$ and $V_{CCB} = 5\text{ V}$, $T_A = 25^\circ\text{C}$.

(2) For I/O ports, the parameter I_{OZ} includes the input leakage current.

(3) This is the increase in supply current for each input that is at one of the specified TTL voltage levels, rather than at 0 or the associated V_{CC} .

Electrical Characteristics

over recommended operating free-air temperature range for $V_{CCA} = 2.3\text{ V}$ to 2.7 V and $V_{CCB} = 3\text{ V}$ to 3.6 V (unless otherwise noted)

PARAMETER	TEST CONDITIONS	V_{CCA}	V_{CCB}	MIN	MAX	UNIT	
V_{OH}	B to A	$I_{OH} = -100\ \mu\text{A}$	2.3 V to 2.7 V	3 V to 3.6 V	$V_{CCA} - 0.2$	V	
		$I_{OH} = -8\ \text{mA}$	2.3 V	3 V to 3.6 V	1.7		
		$I_{OH} = -12\ \text{mA}$	2.7 V	3 V to 3.6 V	1.8		
	A to B	$I_{OH} = -100\ \mu\text{A}$	2.3 V to 2.7 V	3 V to 3.6 V	$V_{CCB} - 0.2$		
		$I_{OH} = -18\ \text{mA}$	2.3 V to 2.7 V	3 V	2.2		
V_{OL}	B to A	$I_{OL} = 100\ \mu\text{A}$	2.3 V to 2.7 V	3 V to 3.6 V		0.2	
		$I_{OL} = 12\ \text{mA}$	2.3 V	3 V to 3.6 V		0.6	
		$I_{OL} = 100\ \mu\text{A}$	2.3 V to 2.7 V	3 V to 3.6 V		0.2	
	A to B	$I_{OL} = 12\ \text{mA}$	2.3 V	3 V		0.55	
I_I	Control inputs	$V_I = V_{CCA}/V_{CCB}$ or GND	2.3 V to 2.7 V	3 V to 3.6 V		±5	μA
$I_{OZ}^{(1)}$	A or B port	$V_O = V_{CCA}/V_{CCB}$ or GND	2.3 V to 2.7 V	3 V to 3.6 V		±10	μA
I_{CC}		$V_I = V_{CCA}/V_{CCB}$ or GND, $I_O = 0$	2.3 V to 2.7 V	3 V to 3.6 V		20	μA
$\Delta I_{CC}^{(2)}$		One input at $V_{CCA}/V_{CCB} - 0.6\text{ V}$, Other inputs at V_{CCA}/V_{CCB} or GND	2.3 V to 2.7 V	3 V to 3.6 V		750	μA

(1) For I/O ports, the parameter I_{OZ} includes the input leakage current.

(2) This is the increase in supply current for each input that is at one of the specified TTL voltage levels, rather than at 0 or the associated V_{CC} .

SN74ALVC164245
16-BIT 2.5-V TO 3.3-V/3.3-V TO 5-V LEVEL-SHIFTING TRANSCEIVER
WITH 3-STATE OUTPUTS



SCAS416P—MARCH 1994—REVISED NOVEMBER 2005

Switching Characteristics

over recommended operating free-air temperature range (unless otherwise noted) (see Figure 1 through Figure 4)

PARAMETER	FROM (INPUT)	TO (OUTPUT)	$V_{CCB} = 3.3\text{ V} \pm 0.3\text{ V}$		$V_{CCB} = 5\text{ V} \pm 0.5\text{ V}$		UNIT
			$V_{CCA} = 2.5\text{ V} \pm 0.2\text{ V}$		$V_{CCA} = 3.3\text{ V} \pm 0.3\text{ V}$		
			MIN	MAX	MIN	MAX	
t_{pd}	A	B	7.6		5.9		ns
	B	A	7.6		6.7		
t_{en}	\overline{OE}	B	11.5		9.3		ns
t_{dis}	\overline{OE}	B	10.5		9.2		ns
t_{en}	\overline{OE}	A	12.3		10.2		ns
t_{dis}	\overline{OE}	A	9.3		9		ns

Operating Characteristics

$T_A = 25^\circ\text{C}$

PARAMETER		TEST CONDITIONS	$V_{CCB} = 3.3\text{ V}$	$V_{CCB} = 5\text{ V}$	UNIT
			$V_{CCA} = 2.5\text{ V}$	$V_{CCA} = 3.3\text{ V}$	
			TYP	TYP	
C_{pd} Power dissipation capacitance	Outputs enabled (B)	$C_L = 50\text{ pF}, f = 10\text{ MHz}$	55	56	pF
	Outputs disabled (B)		27	6	
	Outputs enabled (A)	$C_L = 50\text{ pF}, f = 10\text{ MHz}$	118	56	
	Outputs disabled (A)		58	6	

勝特力材料 886-3-5753170
 勝特力电子(上海) 86-21-54151736
 勝特力电子(深圳) 86-755-83298787
[Http://www.100y.com.tw](http://www.100y.com.tw)

POWER-UP CONSIDERATIONS⁽¹⁾

TI level-translation devices offer an opportunity for successful mixed-voltage signal design. A proper power-up sequence always should be followed to avoid excessive supply current, bus contention, oscillations, or other anomalies caused by improperly biased device pins. Take these precautions to guard against such power-up problems:

1. Connect ground before any supply voltage is applied.
 2. Power up the control side of the device (V_{CCA} for all four of these devices).
 3. Tie \overline{OE} to V_{CCA} with a pullup resistor so that it ramps with V_{CCA} .
 4. Depending on the direction of the data path, DIR can be high or low. If DIR high is needed (A data to B bus), ramp it with V_{CCA} . Otherwise, keep DIR low.
- (1) Refer to the TI application report, *Texas Instruments Voltage-Level-Translation Devices*, literature number SCEA021.

勝特力材料 886-3-5753170
勝特力电子(上海) 86-21-54151736
勝特力电子(深圳) 86-755-83298787
[Http://www.100y.com.tw](http://www.100y.com.tw)

SN74ALVC164245
16-BIT 2.5-V TO 3.3-V/3.3-V TO 5-V LEVEL-SHIFTING TRANSCEIVER
WITH 3-STATE OUTPUTS

SCAS416P—MARCH 1994—REVISED NOVEMBER 2005

PARAMETER MEASUREMENT INFORMATION

$V_{CCA} = 2.5\text{ V} \pm 0.2\text{ V}$ to $V_{CCB} = 3.3\text{ V} \pm 0.3\text{ V}$

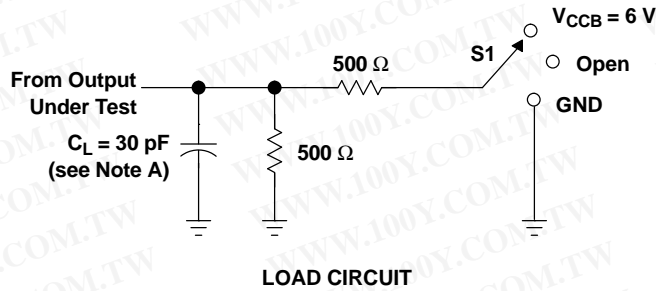

TEST	S1
t_{pd} t_{PLZ}/t_{PZL} t_{PHZ}/t_{PZH}	Open $V_{CCB} = 6\text{ V}$ GND

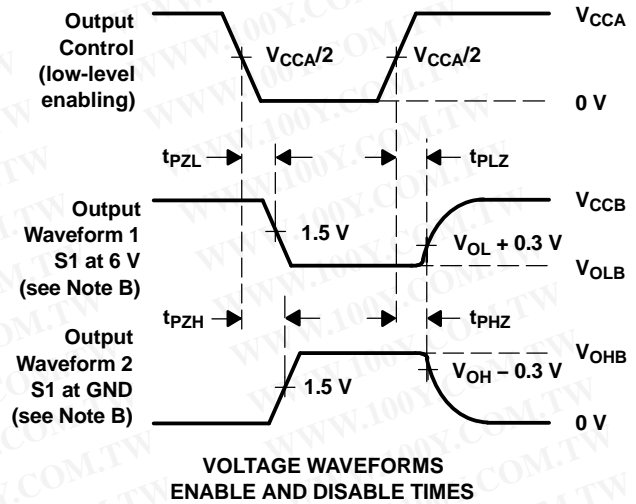
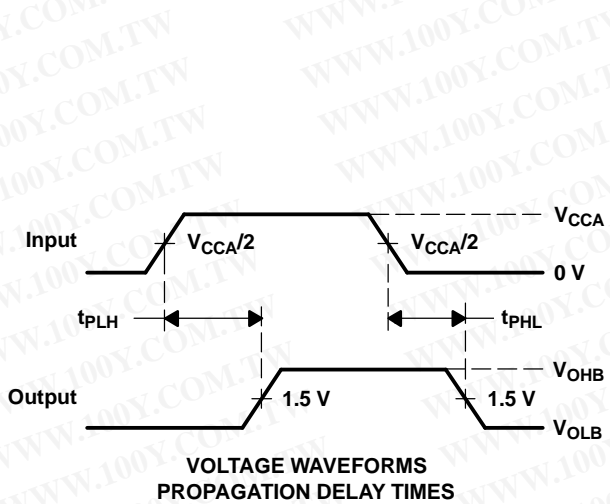

- NOTES: A. C_L includes probe and jig capacitance.
B. Waveform 1 is for an output with internal conditions such that the output is low, except when disabled by the output control. Waveform 2 is for an output with internal conditions such that the output is high, except when disabled by the output control.
C. All input pulses are supplied by generators having the following characteristics: $PRR \leq 10\text{ MHz}$, $Z_O = 50\ \Omega$, $t_r \leq 2\text{ ns}$, $t_f \leq 2\text{ ns}$.
D. The outputs are measured one at a time, with one transition per measurement.
E. t_{PLZ} and t_{PHZ} are the same as t_{dis} .
F. t_{PZL} and t_{PZH} are the same as t_{en} .
G. t_{PLH} and t_{PHL} are the same as t_{pd} .

Figure 1. Load Circuit and Voltage Waveforms

勝特力材料 886-3-5753170
勝特力电子(上海) 86-21-54151736
勝特力电子(深圳) 86-755-83298787
[Http://www.100y.com.tw](http://www.100y.com.tw)

PARAMETER MEASUREMENT INFORMATION

$V_{CCB} = 3.3\text{ V} \pm 0.3\text{ V}$ to $V_{CCA} = 2.5\text{ V} \pm 0.2\text{ V}$

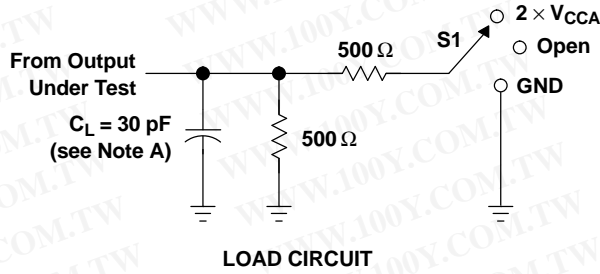

TEST	S1
t_{pd}	Open
t_{PLZ}/t_{PZL}	2 $\times V_{CCA}$
t_{PHZ}/t_{PZH}	GND

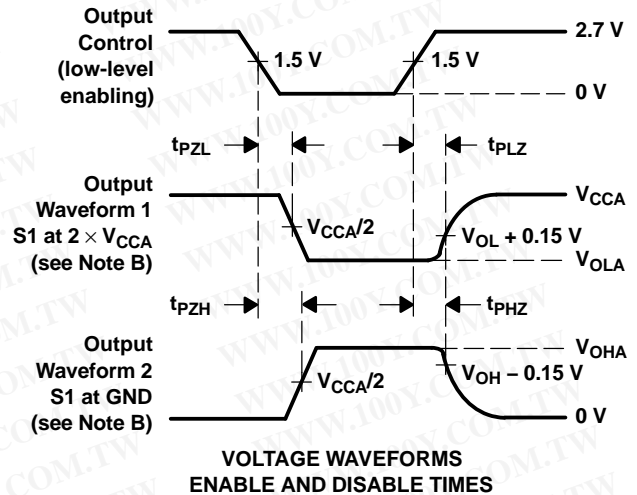
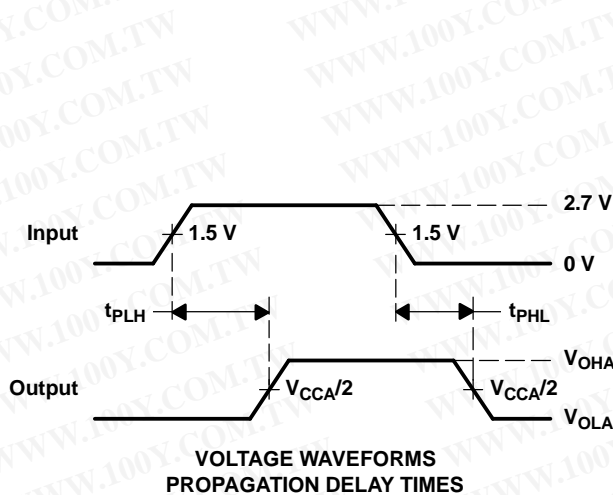

- NOTES:
- A. C_L includes probe and jig capacitance.
 - B. Waveform 1 is for an output with internal conditions such that the output is low, except when disabled by the output control. Waveform 2 is for an output with internal conditions such that the output is high, except when disabled by the output control.
 - C. All input pulses are supplied by generators having the following characteristics: $PRR \leq 10\text{ MHz}$, $Z_O = 50\ \Omega$, $t_r \leq 2\text{ ns}$, $t_f \leq 2\text{ ns}$.
 - D. The outputs are measured one at a time, with one transition per measurement.
 - E. t_{PLZ} and t_{PHZ} are the same as t_{dis} .
 - F. t_{PZL} and t_{PZH} are the same as t_{en} .
 - G. t_{PLH} and t_{PHL} are the same as t_{pd} .

Figure 2. Load Circuit and Voltage Waveforms

勝特力材料 886-3-5753170
 勝特力电子(上海) 86-21-54151736
 勝特力电子(深圳) 86-755-83298787
[Http://www.100y.com.tw](http://www.100y.com.tw)

SN74ALVC164245
16-BIT 2.5-V TO 3.3-V/3.3-V TO 5-V LEVEL-SHIFTING TRANSCEIVER
WITH 3-STATE OUTPUTS

SCAS416P—MARCH 1994—REVISED NOVEMBER 2005

PARAMETER MEASUREMENT INFORMATION

$V_{CCA} = 3.3\text{ V} \pm 0.3\text{ V}$ to $V_{CCB} = 5\text{ V} \pm 0.5\text{ V}$

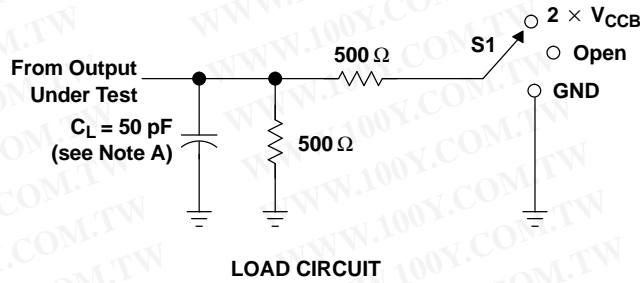

TEST	S1
t_{pd}	Open
t_{PLZ}/t_{PZL}	$2 \times V_{CCB}$
t_{PHZ}/t_{PHL}	GND

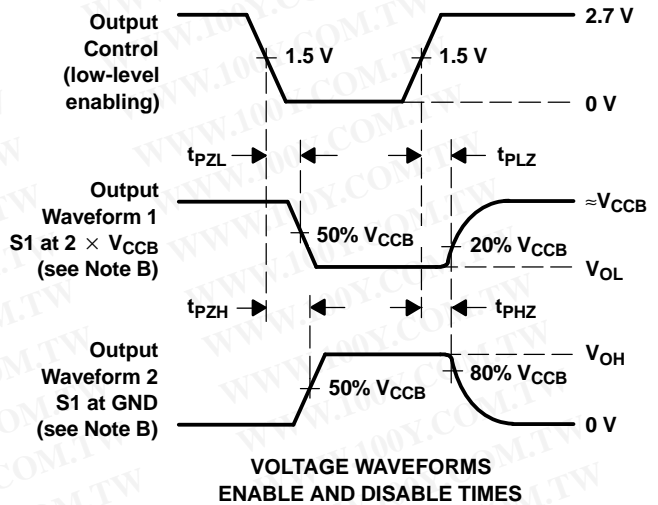
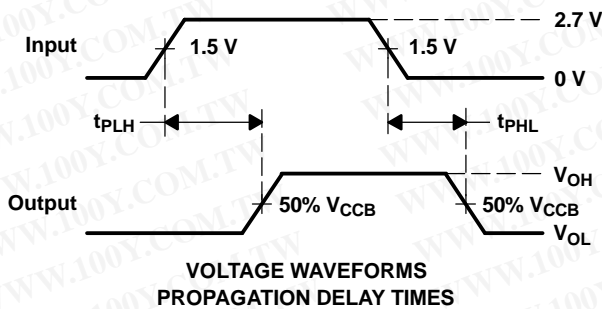

- NOTES:
- A. C_L includes probe and jig capacitance.
 - B. Waveform 1 is for an output with internal conditions such that the output is low, except when disabled by the output control. Waveform 2 is for an output with internal conditions such that the output is high, except when disabled by the output control.
 - C. All input pulses are supplied by generators having the following characteristics: PRR $\leq 10\text{ MHz}$, $Z_O = 50\ \Omega$, $t_r \leq 2.5\text{ ns}$, $t_f \leq 2.5\text{ ns}$.
 - D. The outputs are measured one at a time, with one transition per measurement.
 - E. t_{PLZ} and t_{PHZ} are the same as t_{dis} .
 - F. t_{PZL} and t_{PZH} are the same as t_{en} .
 - G. t_{PLH} and t_{PHL} are the same as t_{pd} .

Figure 3. Load Circuit and Voltage Waveforms

勝特力材料 886-3-5753170
 勝特力电子(上海) 86-21-54151736
 勝特力电子(深圳) 86-755-83298787
[Http://www.100y.com.tw](http://www.100y.com.tw)

PARAMETER MEASUREMENT INFORMATION
 $V_{CCB} = 5\text{ V} \pm 0.5\text{ V}$ to $V_{CCA} = 2.7\text{ V}$ and $3.3\text{ V} \pm 0.3\text{ V}$

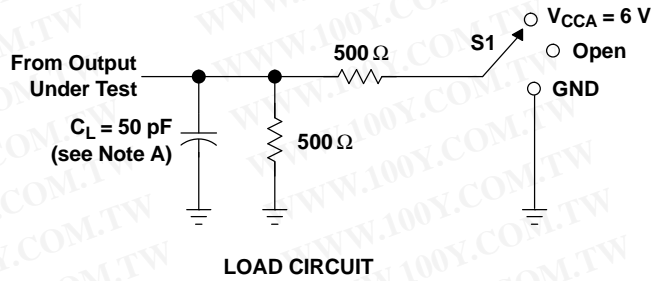

TEST	S1
t_{pd}	Open
t_{PLZ}/t_{PZL}	$V_{CCA} = 6\text{ V}$
t_{PHZ}/t_{PZH}	GND

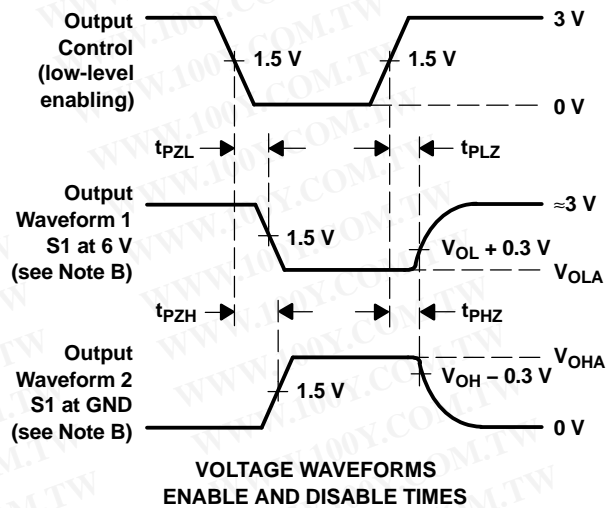
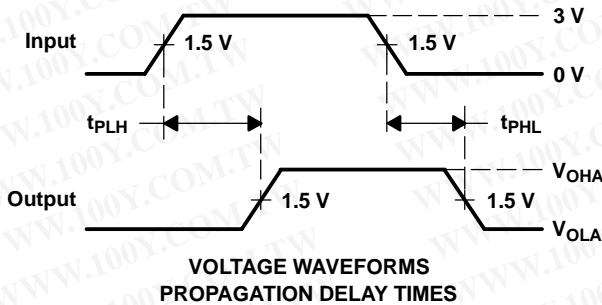

- NOTES:
- C_L includes probe and jig capacitance.
 - Waveform 1 is for an output with internal conditions such that the output is low, except when disabled by the output control. Waveform 2 is for an output with internal conditions such that the output is high, except when disabled by the output control.
 - All input pulses are supplied by generators having the following characteristics: $PRR \leq 10\text{ MHz}$, $Z_O = 50\ \Omega$, $t_r \leq 2.5\text{ ns}$, $t_f \leq 2.5\text{ ns}$.
 - The outputs are measured one at a time, with one transition per measurement.
 - t_{PLZ} and t_{PHZ} are the same as t_{dis} .
 - t_{PZL} and t_{PZH} are the same as t_{en} .
 - t_{PLH} and t_{PHL} are the same as t_{pd} .

Figure 4. Load Circuit and Voltage Waveforms

勝特力材料 886-3-5753170
 勝特力电子(上海) 86-21-54151736
 勝特力电子(深圳) 86-755-83298787
[Http://www.100y.com.tw](http://www.100y.com.tw)

PACKAGING INFORMATION

Orderable Device	Status ⁽¹⁾	Package Type	Package Drawing	Pins	Package Qty	Eco Plan ⁽²⁾	Lead/Ball Finish	MSL Peak Temp ⁽³⁾
74ALVC164245DGGRE4	ACTIVE	TSSOP	DGG	48	2000	Green (RoHS & no Sb/Br)	CU NIPDAU	Level-1-260C-UNLIM
74ALVC164245DGGRG4	ACTIVE	TSSOP	DGG	48	2000	Green (RoHS & no Sb/Br)	CU NIPDAU	Level-1-260C-UNLIM
74ALVC164245DGGTE4	ACTIVE	TSSOP	DGG	48	250	Green (RoHS & no Sb/Br)	CU NIPDAU	Level-1-260C-UNLIM
74ALVC164245DGGTG4	ACTIVE	TSSOP	DGG	48	250	Green (RoHS & no Sb/Br)	CU NIPDAU	Level-1-260C-UNLIM
74ALVC164245DLG4	ACTIVE	SSOP	DL	48	25	Green (RoHS & no Sb/Br)	CU NIPDAU	Level-1-260C-UNLIM
74ALVC164245DLRG4	ACTIVE	SSOP	DL	48	1000	Green (RoHS & no Sb/Br)	CU NIPDAU	Level-1-260C-UNLIM
74ALVC164245GRDR	ACTIVE	BGA MI CROSTA R JUNI OR	GRD	54	1000	TBD	SNPB	Level-1-240C-UNLIM
74ALVC164245ZQLR	ACTIVE	BGA MI CROSTA R JUNI OR	ZQL	56	1000	Green (RoHS & no Sb/Br)	SNAGCU	Level-1-260C-UNLIM
74ALVC164245ZRDR	ACTIVE	BGA MI CROSTA R JUNI OR	ZRD	54	1000	Green (RoHS & no Sb/Br)	SNAGCU	Level-1-260C-UNLIM
SN74ALVC164245DGGR	ACTIVE	TSSOP	DGG	48	2000	Green (RoHS & no Sb/Br)	CU NIPDAU	Level-1-260C-UNLIM
SN74ALVC164245DGGT	ACTIVE	TSSOP	DGG	48	250	Green (RoHS & no Sb/Br)	CU NIPDAU	Level-1-260C-UNLIM
SN74ALVC164245DL	ACTIVE	SSOP	DL	48	25	Green (RoHS & no Sb/Br)	CU NIPDAU	Level-1-260C-UNLIM
SN74ALVC164245DLR	ACTIVE	SSOP	DL	48	1000	Green (RoHS & no Sb/Br)	CU NIPDAU	Level-1-260C-UNLIM
SN74ALVC164245KR	ACTIVE	BGA MI CROSTA R JUNI OR	GQL	56	1000	TBD	SNPB	Level-1-240C-UNLIM

⁽¹⁾ The marketing status values are defined as follows:

ACTIVE: Product device recommended for new designs.

LIFEBUY: TI has announced that the device will be discontinued, and a lifetime-buy period is in effect.

NRND: Not recommended for new designs. Device is in production to support existing customers, but TI does not recommend using this part in a new design.

PREVIEW: Device has been announced but is not in production. Samples may or may not be available.

OBSOLETE: TI has discontinued the production of the device.

⁽²⁾ Eco Plan - The planned eco-friendly classification: Pb-Free (RoHS), Pb-Free (RoHS Exempt), or Green (RoHS & no Sb/Br) - please check <http://www.ti.com/productcontent> for the latest availability information and additional product content details.

TBD: The Pb-Free/Green conversion plan has not been defined.

Pb-Free (RoHS): TI's terms "Lead-Free" or "Pb-Free" mean semiconductor products that are compatible with the current RoHS requirements for all 6 substances, including the requirement that lead not exceed 0.1% by weight in homogeneous materials. Where designed to be soldered at high temperatures, TI Pb-Free products are suitable for use in specified lead-free processes.

Pb-Free (RoHS Exempt): This component has a RoHS exemption for either 1) lead-based flip-chip solder bumps used between the die and package, or 2) lead-based die adhesive used between the die and leadframe. The component is otherwise considered Pb-Free (RoHS compatible) as defined above.

Green (RoHS & no Sb/Br): TI defines "Green" to mean Pb-Free (RoHS compatible), and free of Bromine (Br) and Antimony (Sb) based flame retardants (Br or Sb do not exceed 0.1% by weight in homogeneous material)

⁽³⁾ MSL, Peak Temp. -- The Moisture Sensitivity Level rating according to the JEDEC industry standard classifications, and peak solder temperature.

Important Information and Disclaimer: The information provided on this page represents TI's knowledge and belief as of the date that it is provided. TI bases its knowledge and belief on information provided by third parties, and makes no representation or warranty as to the accuracy of such information. Efforts are underway to better integrate information from third parties. TI has taken and continues to take reasonable steps to provide representative and accurate information but may not have conducted destructive testing or chemical analysis on incoming materials and chemicals. TI and TI suppliers consider certain information to be proprietary, and thus CAS numbers and other limited information may not be available for release.

In no event shall TI's liability arising out of such information exceed the total purchase price of the TI part(s) at issue in this document sold by TI to Customer on an annual basis.

勝特力材料 886-3-5753170
勝特力电子(上海) 86-21-54151736
勝特力电子(深圳) 86-755-83298787
[Http://www.100y.com.tw](http://www.100y.com.tw)

TAPE AND REEL INFORMATION

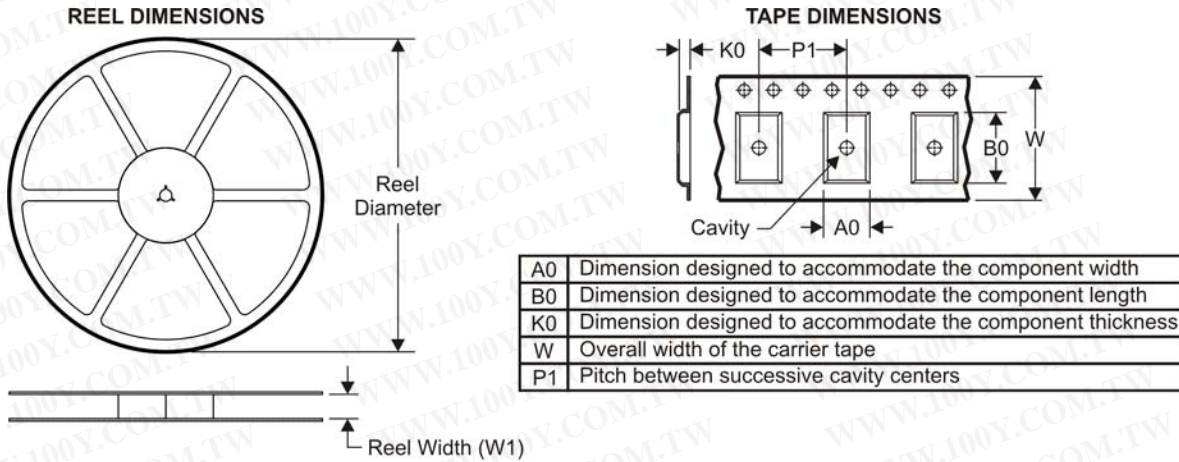

QUADRANT ASSIGNMENTS FOR PIN 1 ORIENTATION IN TAPE

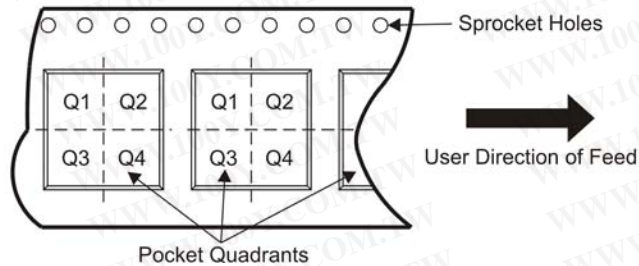

*All dimensions are nominal

Device	Package Type	Package Drawing	Pins	SPQ	Reel Diameter (mm)	Reel Width W1 (mm)	A0 (mm)	B0 (mm)	K0 (mm)	P1 (mm)	W (mm)	Pin1 Quadrant
74ALVC164245GRDR	BGA MICROSTAR JUNIOR	GRD	54	1000	330.0	16.4	5.8	8.3	1.55	8.0	16.0	Q1
74ALVC164245ZQLR	BGA MICROSTAR JUNIOR	ZQL	56	1000	330.0	16.4	4.8	7.3	1.45	8.0	16.0	Q1
74ALVC164245ZRDR	BGA MICROSTAR JUNIOR	ZRD	54	1000	330.0	16.4	5.8	8.3	1.55	8.0	16.0	Q1
SN74ALVC164245DGGR	TSSOP	DGG	48	2000	330.0	24.4	8.6	15.8	1.8	12.0	24.0	Q1
SN74ALVC164245DLR	SSOP	DL	48	1000	330.0	32.4	11.35	16.2	3.1	16.0	32.0	Q1
SN74ALVC164245KR	BGA MICROSTAR JUNIOR	GQL	56	1000	330.0	16.4	4.8	7.3	1.45	8.0	16.0	Q1

勝特力材料 886-3-5753170
 勝特力电子(上海) 86-21-54151736
 勝特力电子(深圳) 86-755-83298787
[Http://www.100y.com.tw](http://www.100y.com.tw)

TAPE AND REEL BOX DIMENSIONS

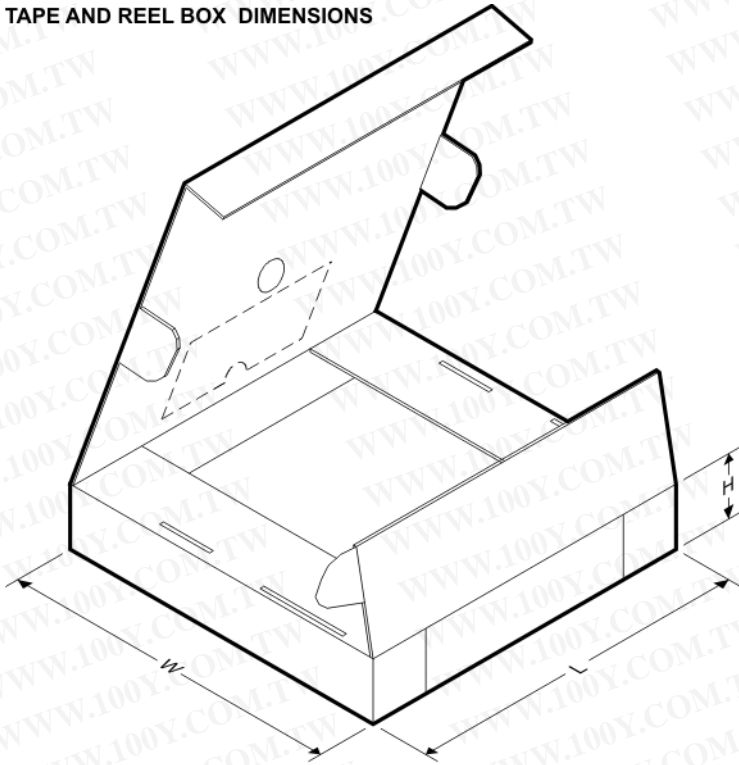

*All dimensions are nominal

Device	Package Type	Package Drawing	Pins	SPQ	Length (mm)	Width (mm)	Height (mm)
74ALVC164245GRDR	BGA MICROSTAR JUNIOR	GRD	54	1000	346.0	346.0	33.0
74ALVC164245ZQLR	BGA MICROSTAR JUNIOR	ZQL	56	1000	346.0	346.0	33.0
74ALVC164245ZRDR	BGA MICROSTAR JUNIOR	ZRD	54	1000	346.0	346.0	33.0
SN74ALVC164245DGGR	TSSOP	DGG	48	2000	346.0	346.0	41.0
SN74ALVC164245DLR	SSOP	DL	48	1000	346.0	346.0	49.0
SN74ALVC164245KR	BGA MICROSTAR JUNIOR	GQL	56	1000	346.0	346.0	33.0

勝特力材料 886-3-5753170
 勝特力电子(上海) 86-21-54151736
 勝特力电子(深圳) 86-755-83298787
[Http://www.100y.com.tw](http://www.100y.com.tw)

GQL (R-PBGA-N56)

PLASTIC BALL GRID ARRAY

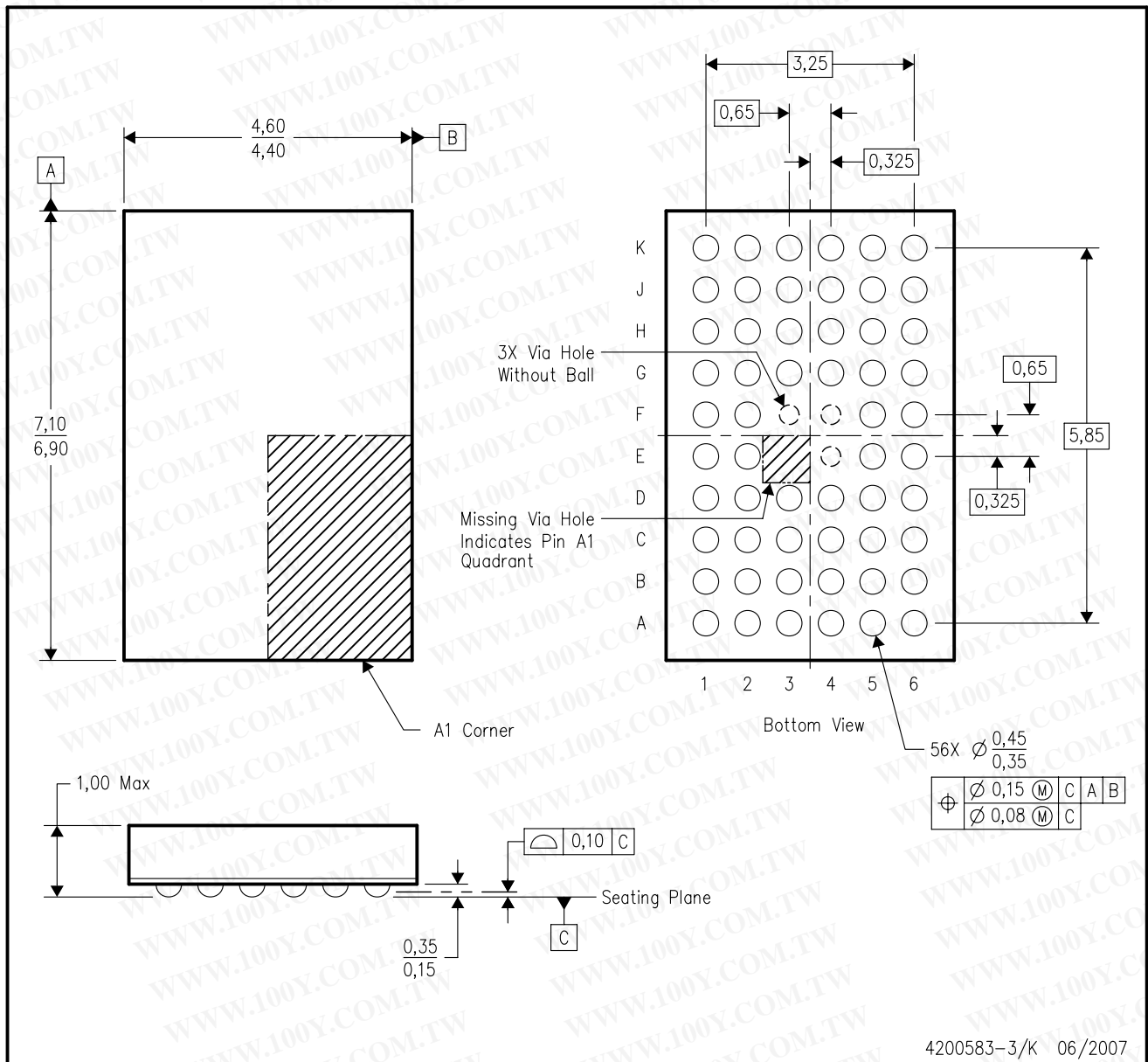

- NOTES:
- A. All linear dimensions are in millimeters. Dimensioning and tolerancing per ASME Y14.5M-1994.
 - B. This drawing is subject to change without notice.
 - C. Falls within JEDEC MO-285 variation BA-2.
 - D. This package is tin-lead (SnPb). Refer to the 56 ZQL package (drawing 4204437) for lead-free.

勝特力材料 886-3-5753170
 勝特力电子(上海) 86-21-54151736
 勝特力电子(深圳) 86-755-83298787
[Http://www.100y.com.tw](http://www.100y.com.tw)

ZQL (R-PBGA-N56)

PLASTIC BALL GRID ARRAY

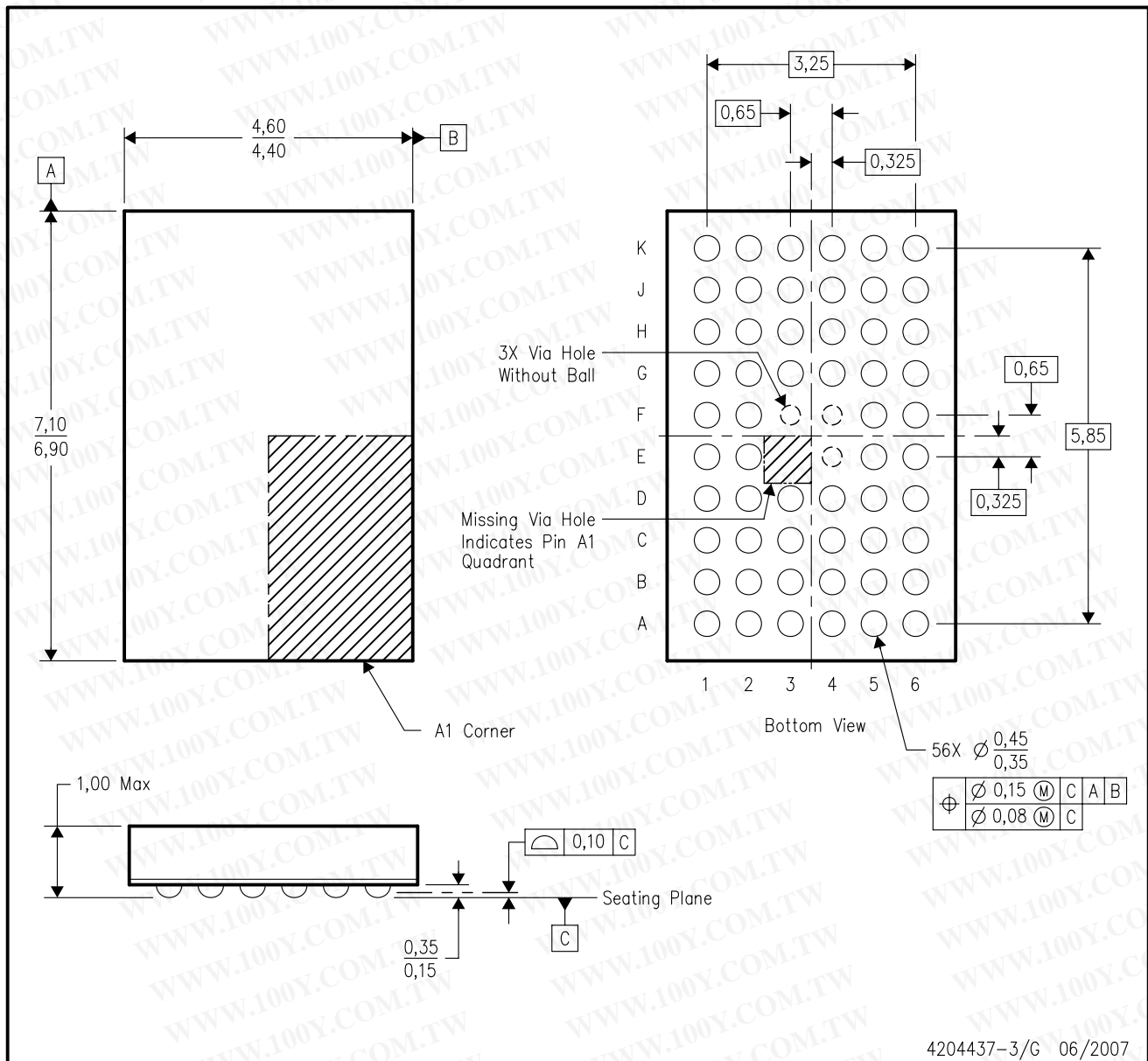

- NOTES:
- A. All linear dimensions are in millimeters. Dimensioning and tolerancing per ASME Y14.5M-1994.
 - B. This drawing is subject to change without notice.
 - C. Falls within JEDEC MO-285 variation BA-2.
 - D. This package is lead-free. Refer to the 56 GQL package (drawing 4200583) for tin-lead (SnPb).

DL (R-PDSO-G)**

PLASTIC SMALL-OUTLINE PACKAGE

48 PINS SHOWN

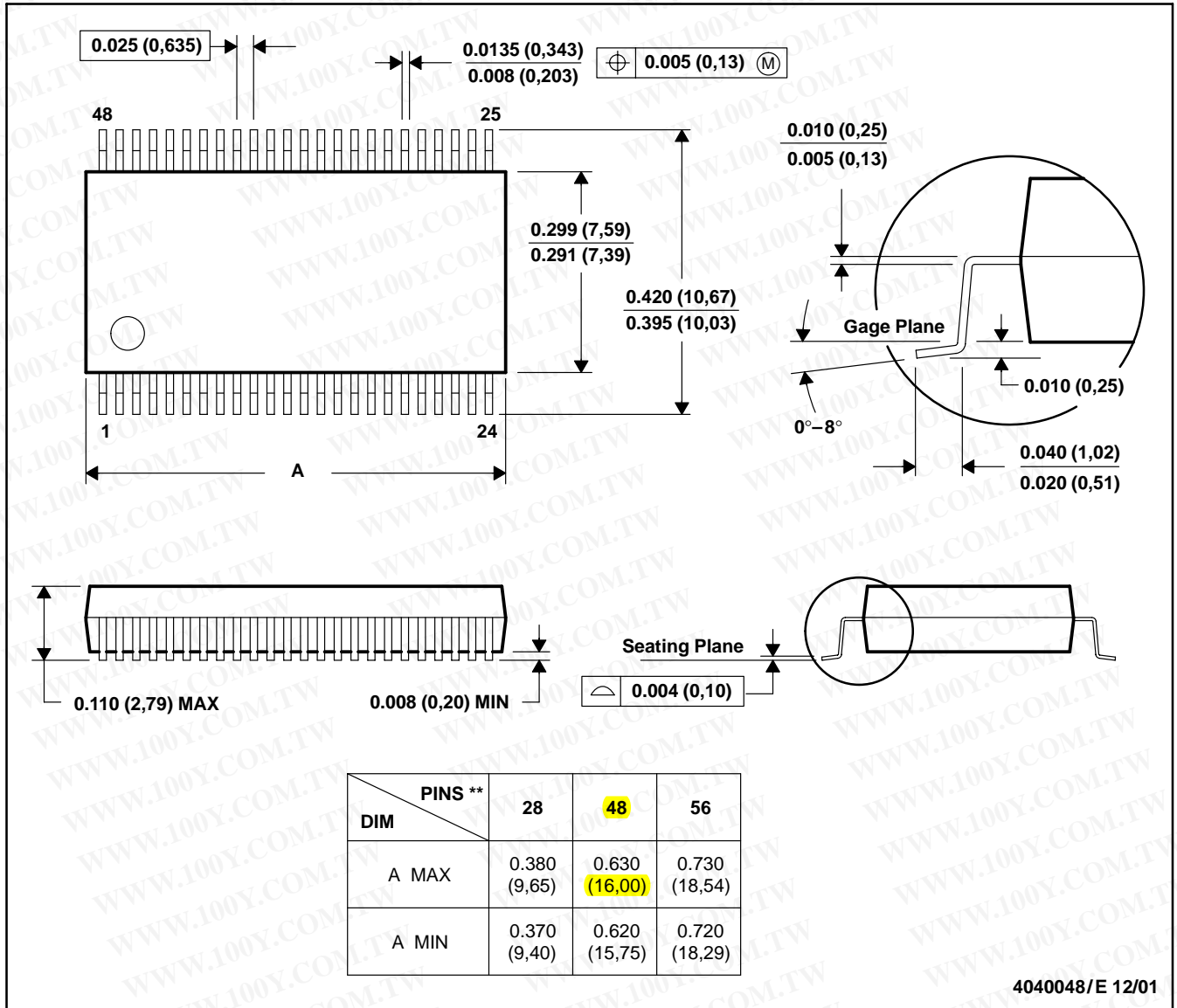

4040048/E 12/01

- NOTES: A. All linear dimensions are in inches (millimeters).
 B. This drawing is subject to change without notice.
 C. Body dimensions do not include mold flash or protrusion not to exceed 0.006 (0,15).
 D. Falls within JEDEC MO-118

勝特力材料 886-3-5753170
 勝特力电子(上海) 86-21-54151736
 勝特力电子(深圳) 86-755-83298787
[Http://www.100y.com.tw](http://www.100y.com.tw)

DGG (R-PDSO-G**)

PLASTIC SMALL-OUTLINE PACKAGE

48 PINS SHOWN

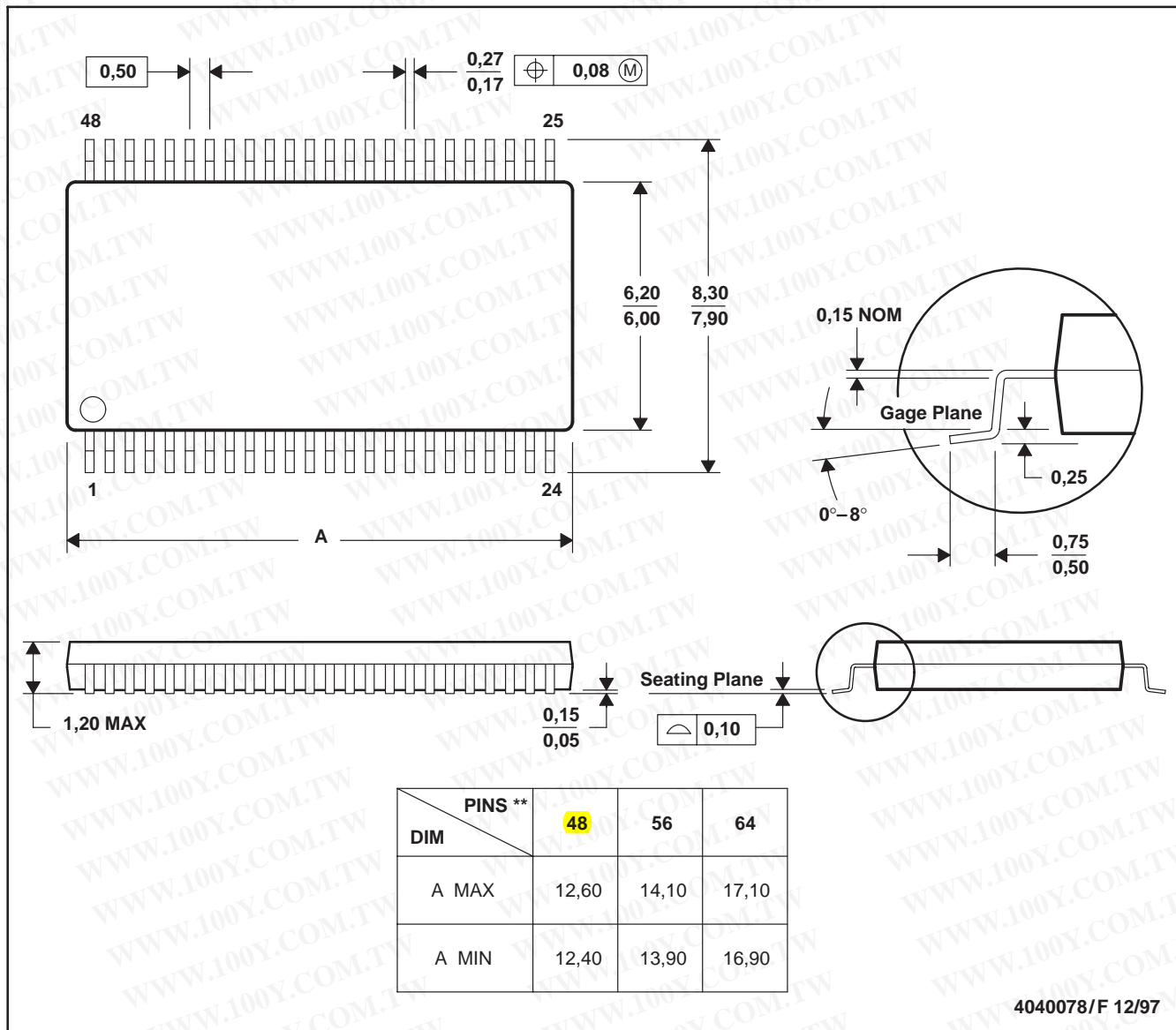

- NOTES: A. All linear dimensions are in millimeters.
 B. This drawing is subject to change without notice.
 C. Body dimensions do not include mold protrusion not to exceed 0,15.
 D. Falls within JEDEC MO-153

勝特力材料 886-3-5753170
 勝特力电子(上海) 86-21-54151736
 勝特力电子(深圳) 86-755-83298787
[Http://www.100y.com.tw](http://www.100y.com.tw)

GRD (R-PBGA-N54)

PLASTIC BALL GRID ARRAY

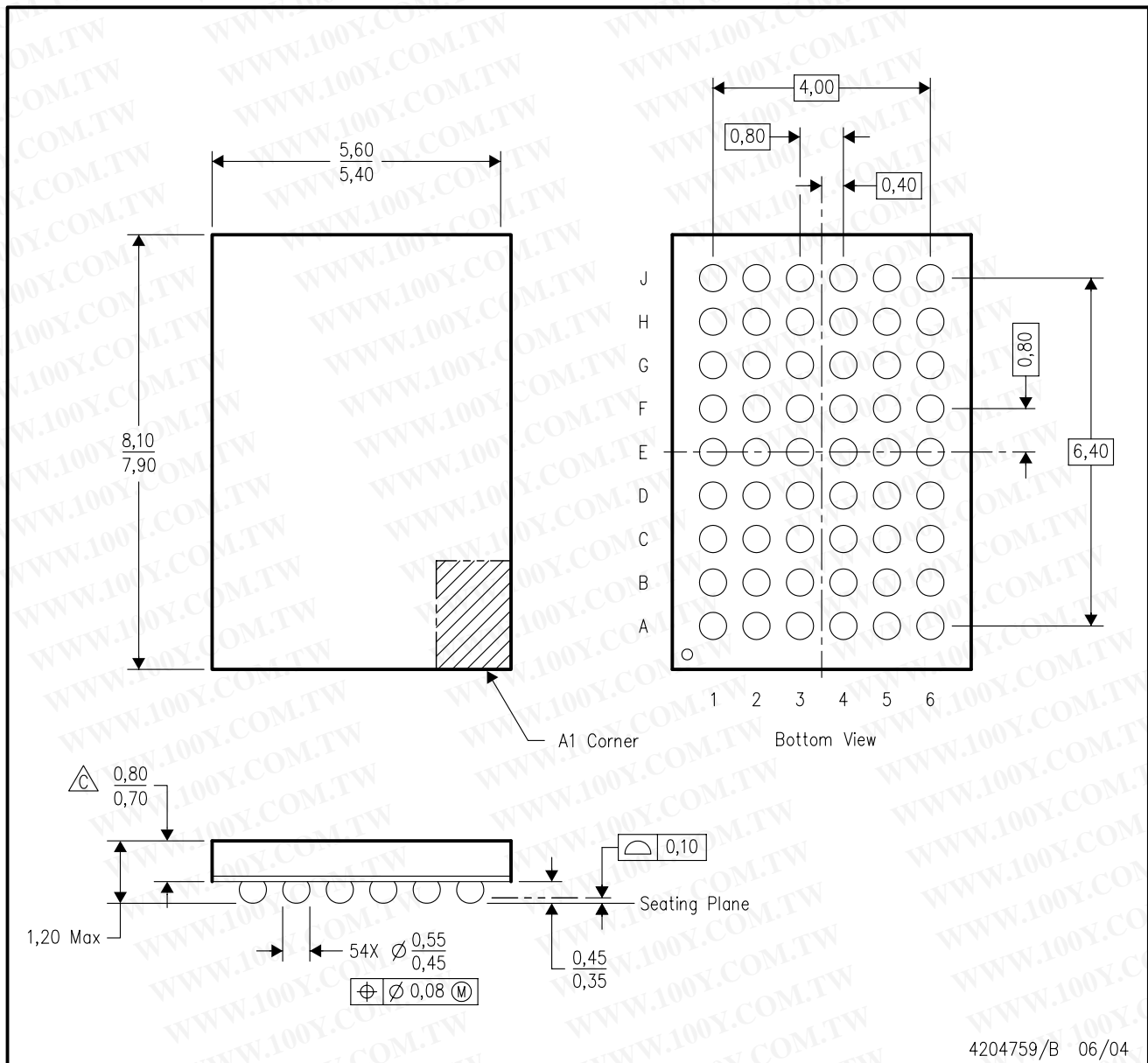



- NOTES:
- A. All linear dimensions are in millimeters.
 - B. This drawing is subject to change without notice.
 - \triangle Falls within JEDEC MO-205 variation DD.
 - D. This package is tin-lead (SnPb). Refer to the 54 ZRD package (drawing 4204760) for lead-free.

勝特力材料 886-3-5753170
 勝特力电子(上海) 86-21-54151736
 勝特力电子(深圳) 86-755-83298787
[Http://www.100y.com.tw](http://www.100y.com.tw)

ZRD (R-PBGA-N54)

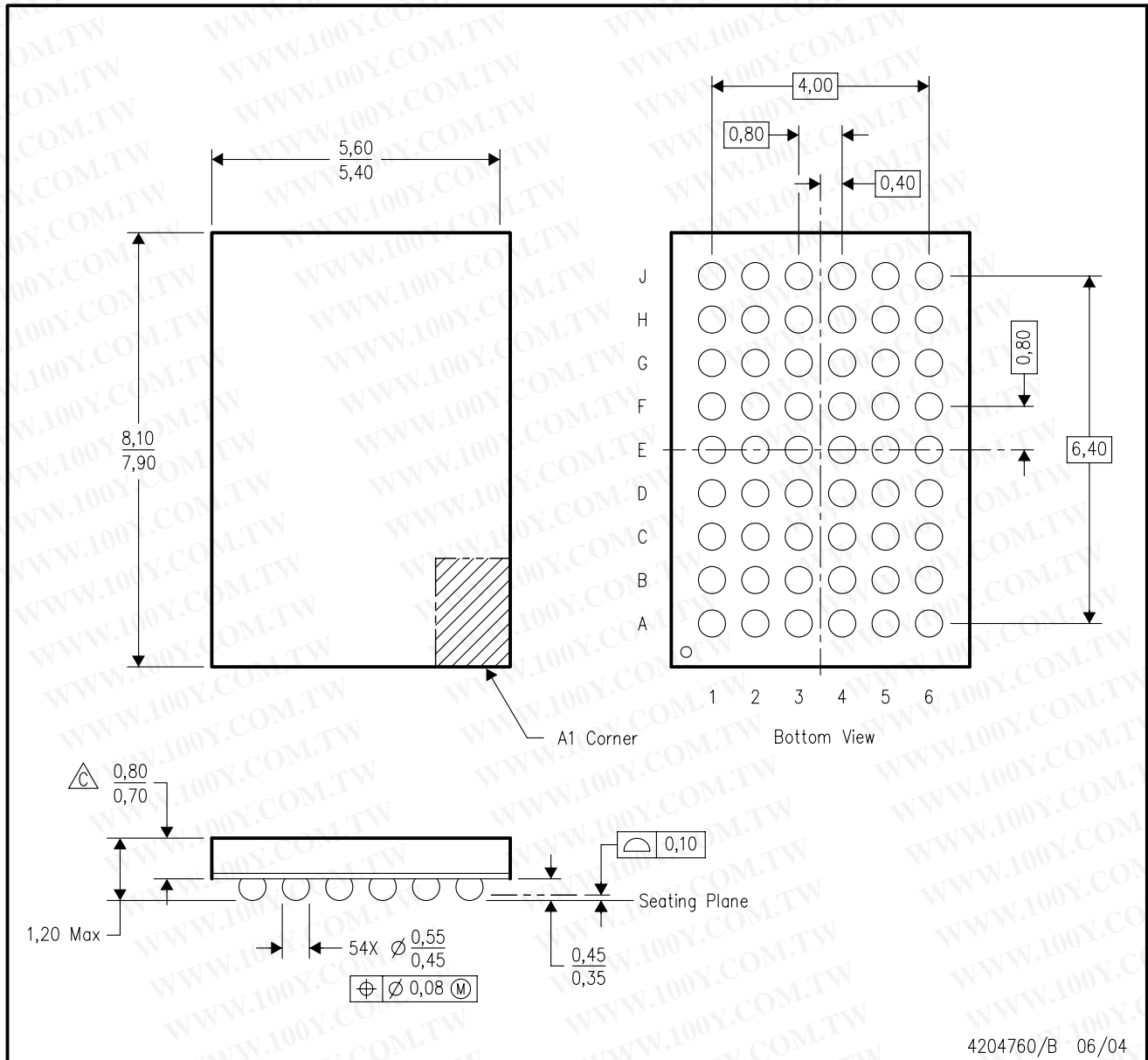
PLASTIC BALL GRID ARRAY



- NOTES:
- A. All linear dimensions are in millimeters.
 - B. This drawing is subject to change without notice.
 -  Falls within JEDEC M0-205 variation DD.
 - D. This package is lead-free. Refer to the 54 GRD package (drawing 4204759) for tin-lead (SnPb).

勝特力材料 886-3-5753170
 勝特力电子(上海) 86-21-54151736
 勝特力电子(深圳) 86-755-83298787
[Http://www.100y.com.tw](http://www.100y.com.tw)

IMPORTANT NOTICE

Texas Instruments Incorporated and its subsidiaries (TI) reserve the right to make corrections, modifications, enhancements, improvements, and other changes to its products and services at any time and to discontinue any product or service without notice. Customers should obtain the latest relevant information before placing orders and should verify that such information is current and complete. All products are sold subject to TI's terms and conditions of sale supplied at the time of order acknowledgment.

TI warrants performance of its hardware products to the specifications applicable at the time of sale in accordance with TI's standard warranty. Testing and other quality control techniques are used to the extent TI deems necessary to support this warranty. Except where mandated by government requirements, testing of all parameters of each product is not necessarily performed.

TI assumes no liability for applications assistance or customer product design. Customers are responsible for their products and applications using TI components. To minimize the risks associated with customer products and applications, customers should provide adequate design and operating safeguards.

TI does not warrant or represent that any license, either express or implied, is granted under any TI patent right, copyright, mask work right, or other TI intellectual property right relating to any combination, machine, or process in which TI products or services are used. Information published by TI regarding third-party products or services does not constitute a license from TI to use such products or services or a warranty or endorsement thereof. Use of such information may require a license from a third party under the patents or other intellectual property of the third party, or a license from TI under the patents or other intellectual property of TI.

Reproduction of TI information in TI data books or data sheets is permissible only if reproduction is without alteration and is accompanied by all associated warranties, conditions, limitations, and notices. Reproduction of this information with alteration is an unfair and deceptive business practice. TI is not responsible or liable for such altered documentation. Information of third parties may be subject to additional restrictions.

Resale of TI products or services with statements different from or beyond the parameters stated by TI for that product or service voids all express and any implied warranties for the associated TI product or service and is an unfair and deceptive business practice. TI is not responsible or liable for any such statements.

TI products are not authorized for use in safety-critical applications (such as life support) where a failure of the TI product would reasonably be expected to cause severe personal injury or death, unless officers of the parties have executed an agreement specifically governing such use. Buyers represent that they have all necessary expertise in the safety and regulatory ramifications of their applications, and acknowledge and agree that they are solely responsible for all legal, regulatory and safety-related requirements concerning their products and any use of TI products in such safety-critical applications, notwithstanding any applications-related information or support that may be provided by TI. Further, Buyers must fully indemnify TI and its representatives against any damages arising out of the use of TI products in such safety-critical applications.

TI products are neither designed nor intended for use in military/aerospace applications or environments unless the TI products are specifically designated by TI as military-grade or "enhanced plastic." Only products designated by TI as military-grade meet military specifications. Buyers acknowledge and agree that any such use of TI products which TI has not designated as military-grade is solely at the Buyer's risk, and that they are solely responsible for compliance with all legal and regulatory requirements in connection with such use.

TI products are neither designed nor intended for use in automotive applications or environments unless the specific TI products are designated by TI as compliant with ISO/TS 16949 requirements. Buyers acknowledge and agree that, if they use any non-designated products in automotive applications, TI will not be responsible for any failure to meet such requirements.

Following are URLs where you can obtain information on other Texas Instruments products and application solutions:

Products

Amplifiers	amplifier.ti.com
Data Converters	dataconverter.ti.com
DSP	dsp.ti.com
Clocks and Timers	www.ti.com/clocks
Interface	interface.ti.com
Logic	logic.ti.com
Power Mgmt	power.ti.com
Microcontrollers	microcontroller.ti.com
RFID	www.ti-rfid.com
RF/IF and ZigBee® Solutions	www.ti.com/lprf

Applications

Audio	www.ti.com/audio
Automotive	www.ti.com/automotive
Broadband	www.ti.com/broadband
Digital Control	www.ti.com/digitalcontrol
Medical	www.ti.com/medical
Military	www.ti.com/military
Optical Networking	www.ti.com/opticalnetwork
Security	www.ti.com/security
Telephony	www.ti.com/telephony
Video & Imaging	www.ti.com/video
Wireless	www.ti.com/wireless

Mailing Address: Texas Instruments, Post Office Box 655303, Dallas, Texas 75265
Copyright © 2008, Texas Instruments Incorporated

勝特力材料 886-3-5753170
勝特力电子(上海) 86-21-54151736
勝特力电子(深圳) 86-755-83298787
[Http://www.100y.com.tw](http://www.100y.com.tw)