

FEATURES

- Bidirectional Voltage Translator
- 5.5 V on A Port and 2.7 V to 3.6 V on B Port
- Control Inputs V_{IH}/V_{IL} Levels Are Referenced to V_{CCA} Voltage
- Latch-Up Performance Exceeds 250 mA Per JESD 17
- ESD Protection Exceeds JESD 22
 - 2000-V Human-Body Model (A114-A)
 - 200-V Machine Model (A115-A)
 - 1000-V Charged-Device Model (C101)

DESCRIPTION/ORDERING INFORMATION

This 8-bit (octal) noninverting bus transceiver contains two separate supply rails; B port has V_{CCB} , which is set at 3.3 V, and A port has V_{CCA} , which is set at 5 V. This allows for translation from a 3.3-V to a 5-V environment, and vice versa.

The SN74LVC4245A is designed for asynchronous communication between data buses. The device transmits data from the A bus to the B bus or from the B bus to the A bus, depending on the logic level at the direction-control (DIR) input. The output-enable (\overline{OE}) input can be used to disable the device so the buses are effectively isolated. The control circuitry (DIR, \overline{OE}) is powered by V_{CCA} .

The SN74LVC4245A pinout allows the designer to switch to a normal all-3.3-V or all-5-V 20-pin '245 device without board re-layout. The designer uses the data paths for pins 2–11 and 14–23 of the SN74LVC4245A to align with the conventional '245 pinout.

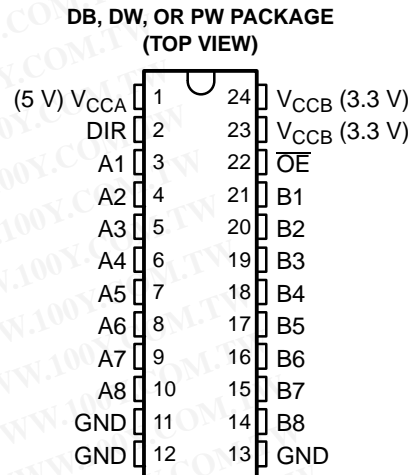

ORDERING INFORMATION

T_A	PACKAGE ⁽¹⁾		ORDERABLE PART NUMBER	TOP-SIDE MARKING
–40°C to 85°C	SOIC – DW	Tube of 25	SN74LVC4245ADW	LVC4245A
		Reel of 2000	SN74LVC4245ADWR	
	SSOP – DB	Reel of 2000	SN74LVC4245ADBR	LJ245A
	TSSOP – PW	Tube of 60	SN74LVC4245APW	LJ245A
		Reel of 2000	SN74LVC4245APWR	
		Reel of 250	SN74LVC4245APWT	

(1) Package drawings, standard packing quantities, thermal data, symbolization, and PCB design guidelines are available at www.ti.com/sc/package.

FUNCTION TABLE

INPUTS		OPERATION
\overline{OE}	DIR	
L	L	B data to A bus
L	H	A data to B bus
H	X	Isolation

勝特力材料 886-3-5753170
 勝特力电子(上海) 86-21-34970699
 勝特力电子(深圳) 86-755-83298787
[Http://www.100y.com.tw](http://www.100y.com.tw)



Please be aware that an important notice concerning availability, standard warranty, and use in critical applications of Texas Instruments semiconductor products and disclaimers thereto appears at the end of this data sheet.

SN74LVC4245A OCTAL BUS TRANSCEIVER AND 3.3-V TO 5-V SHIFTER WITH 3-STATE OUTPUTS



SCAS375H—MARCH 1994—REVISED MARCH 2005

LOGIC DIAGRAM (POSITIVE LOGIC)

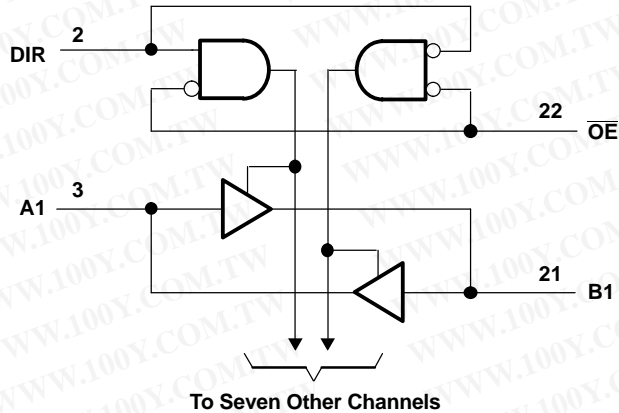

Absolute Maximum Ratings⁽¹⁾

over operating free-air temperature range for $V_{CCA} = 4.5\text{ V to }5.5\text{ V}$ (unless otherwise noted)

		MIN	MAX	UNIT
V_{CCA}	Supply voltage range	-0.5	6.5	V
V_I	Input voltage range	A port ⁽²⁾	$V_{CCA} + 0.5$	V
		Control inputs	6	
V_O	Output voltage range	-0.5	$V_{CCA} + 0.5$	V
I_{IK}	Input clamp current		-50	mA
I_{OK}	Output clamp current		-50	mA
I_O	Continuous output current		±50	mA
	Continuous current through each V_{CCA} or GND		±100	mA
θ_{JA}	Package thermal impedance ⁽³⁾	DB package	63	°C/W
		DW package	46	
		PW package	88	
T_{stg}	Storage temperature range	-65	150	°C

- (1) Stresses beyond those listed under "absolute maximum ratings" may cause permanent damage to the device. These are stress ratings only, and functional operation of the device at these or any other conditions beyond those indicated under "recommended operating conditions" is not implied. Exposure to absolute-maximum-rated conditions for extended periods may affect device reliability.
- (2) This value is limited to 6 V maximum.
- (3) The package thermal impedance is calculated in accordance with JESD 51-7.

勝特力材料 886-3-5753170
勝特力电子(上海) 86-21-34970699
勝特力电子(深圳) 86-755-83298787
[Http://www.100y.com.tw](http://www.100y.com.tw)

Absolute Maximum Ratings⁽¹⁾

 over operating free-air temperature range for $V_{CCB} = 2.7\text{ V to }3.6\text{ V}$ (unless otherwise noted)

		MIN	MAX	UNIT
V_{CCB}	Supply voltage range	-0.5	4.6	V
V_I	Input voltage range	-0.5	$V_{CCB} + 0.5$	V
V_O	Output voltage range	-0.5	$V_{CCB} + 0.5$	V
I_{IK}	Input clamp current	$V_I < 0$	-50	mA
I_{OK}	Output clamp current	$V_O < 0$	-50	mA
I_O	Continuous output current		±50	mA
	Continuous current through V_{CCB} or GND		±100	mA
θ_{JA}	Package thermal impedance ⁽³⁾	DB package	63	°C/W
		DW package	46	
		PW package	88	
T_{stg}	Storage temperature range	-65	150	°C

(1) Stresses beyond those listed under "absolute maximum ratings" may cause permanent damage to the device. These are stress ratings only, and functional operation of the device at these or any other conditions beyond those indicated under "recommended operating conditions" is not implied. Exposure to absolute-maximum-rated conditions for extended periods may affect device reliability.

(2) This value is limited to 4.6 V maximum.

(3) The package thermal impedance is calculated in accordance with JESD 51-7.

Recommended Operating Conditions⁽¹⁾

 for $V_{CCA} = 4.5\text{ V to }5.5\text{ V}$

		MIN	MAX	UNIT
V_{CCA}	Supply voltage	4.5	5.5	V
V_{IH}	High-level input voltage	2		V
V_{IL}	Low-level input voltage		0.8	V
V_{IA}	Input voltage	0	V_{CCA}	V
V_{OA}	Output voltage	0	V_{CCA}	V
I_{OH}	High-level output current		-24	mA
I_{OL}	Low-level output current		24	mA
T_A	Operating free-air temperature	-40	85	°C

(1) All unused inputs of the device must be held at the associated V_{CC} or GND to ensure proper device operation. Refer to the TI application report, *Implications of Slow or Floating CMOS Inputs*, literature number SCBA004.

Recommended Operating Conditions⁽¹⁾

 for $V_{CCB} = 2.7\text{ V to }3.6\text{ V}$

		MIN	MAX	UNIT
V_{CCB}	Supply voltage	2.7	3.6	V
V_{IH}	High-level input voltage	$V_{CCB} = 2.7\text{ V to }3.6\text{ V}$	2	V
V_{IL}	Low-level input voltage	$V_{CCB} = 2.7\text{ V to }3.6\text{ V}$	0.8	V
V_{IB}	Input voltage	0	V_{CCB}	V
V_{OB}	Output voltage	0	V_{CCB}	V
I_{OH}	High-level output current	$V_{CCB} = 2.7\text{ V}$	-12	mA
		$V_{CCB} = 3\text{ V}$	-24	
I_{OL}	Low-level output current	$V_{CCB} = 2.7\text{ V}$	12	mA
		$V_{CCB} = 3\text{ V}$	24	
T_A	Operating free-air temperature	-40	85	°C

(1) All unused inputs of the device must be held at the associated V_{CC} or GND to ensure proper device operation. Refer to the TI application report, *Implications of Slow or Floating CMOS Inputs*, literature number SCBA004.

SN74LVC4245A

OCTAL BUS TRANSCEIVER AND 3.3-V TO 5-V SHIFTER WITH 3-STATE OUTPUTS



SCAS375H—MARCH 1994—REVISED MARCH 2005

Electrical Characteristics⁽¹⁾

over recommended operating free-air temperature range for $V_{CCA} = 4.5\text{ V to }5.5\text{ V}$ (unless otherwise noted)

PARAMETER		TEST CONDITIONS	V_{CCA}	MIN	TYP ⁽²⁾	MAX	UNIT
V_{OH}		$I_{OH} = -100\ \mu\text{A}$	4.5 V	4.3			V
			5.5 V	5.3			
		$I_{OH} = -24\ \text{mA}$	4.5 V	3.7			
			5.5 V	4.7			
V_{OL}		$I_{OL} = 100\ \mu\text{A}$	4.5 V			0.2	V
			5.5 V			0.2	
		$I_{OL} = 24\ \text{mA}$	4.5 V			0.55	
			5.5 V			0.55	
I_I	Control inputs	$V_I = V_{CCA}$ or GND	5.5 V			± 1	μA
$I_{OZ}^{(3)}$	A port	$V_O = V_{CCA}$ or GND	5.5 V			± 5	μA
I_{CCA}		$V_I = V_{CCA}$ or GND, $I_O = 0$	5.5 V			80	μA
$\Delta I_{CCA}^{(4)}$		One input at 3.4 V, Other inputs at V_{CCA} or GND	5.5 V			1.5	mA
C_i	Control inputs	$V_I = V_{CCA}$ or GND	Open		5		pF
C_{io}	A port	$V_O = V_{CCA}$ or GND	5 V		11		pF

(1) $V_{CCB} = 2.7\text{ V to }3.6\text{ V}$

(2) All typical values are measured at $V_{CC} = 5\text{ V}$, $T_A = 25^\circ\text{C}$.

(3) For I/O ports, the parameter I_{OZ} includes the input leakage current.

(4) This is the increase in supply current for each input that is at one of the specified TTL voltage levels, rather than 0 V or the associated V_{CC} .

Electrical Characteristics⁽¹⁾

over recommended operating free-air temperature range for $V_{CCB} = 2.7\text{ V to }3.6\text{ V}$ (unless otherwise noted)

PARAMETER		TEST CONDITIONS	V_{CCB}	MIN	TYP ⁽²⁾	MAX	UNIT
V_{OH}		$I_{OH} = -100\ \mu\text{A}$	2.7 V to 3.6 V	$V_{CC} - 0.2$			V
			2.7 V	2.2			
		$I_{OH} = -12\ \text{mA}$	3 V	2.4			
			3 V	2			
V_{OL}		$I_{OL} = 100\ \mu\text{A}$	2.7 V to 3.6 V			0.2	V
			2.7 V			0.4	
			3 V			0.55	
$I_{OZ}^{(3)}$	B port	$V_O = V_{CCB}$ or GND	3.6 V			± 5	μA
I_{CCB}		$V_I = V_{CCB}$ or GND, $I_O = 0$	3.6 V			50	μA
$\Delta I_{CCB}^{(4)}$		One input at $V_{CCB} - 0.6\text{ V}$, Other inputs at V_{CCB} or GND	2.7 V to 3.6 V			0.5	mA
C_{io}	B port	$V_O = V_{CCB}$ or GND	3.3 V		11		pF

(1) $V_{CCA} = 5\text{ V} \pm 0.5\text{ V}$

(2) All typical values are measured at $V_{CC} = 3.3\text{ V}$, $T_A = 25^\circ\text{C}$.

(3) For I/O ports, the parameter I_{OZ} includes the input leakage current.

(4) This is the increase in supply current for each input that is at one of the specified TTL voltage levels, rather than 0 V or the associated V_{CC} .

勝特力材料 886-3-5753170
 勝特力电子(上海) 86-21-34970699
 勝特力电子(深圳) 86-755-83298787
[Http://www.100y.com.tw](http://www.100y.com.tw)

Switching Characteristics

over recommended operating free-air temperature range, $C_L = 50$ pF (unless otherwise noted) (see Figure 1 and Figure 2)

PARAMETER	FROM (INPUT)	TO (OUTPUT)	$V_{CCA} = 5\text{ V} \pm 0.5\text{ V}$, $V_{CCB} = 2.7\text{ V to } 3.6\text{ V}$		UNIT
			MIN	MAX	
t_{PHL}	A	B	1	6.3	ns
t_{PLH}			1	6.7	
t_{PHL}	B	A	1	6.1	ns
t_{PLH}			1	5	
t_{PZL}	\overline{OE}	A	1	9	ns
t_{PZH}			1	8.1	
t_{PZL}	\overline{OE}	B	1	8.8	ns
t_{PZH}			1	9.8	
t_{PLZ}	\overline{OE}	A	1	7	ns
t_{PHZ}			1	5.8	
t_{PLZ}	\overline{OE}	B	1	7.7	ns
t_{PHZ}			1	7.8	

Operating Characteristics

$V_{CCA} = 4.5\text{ V to } 5.5\text{ V}$, $V_{CCB} = 2.7\text{ V to } 3.6\text{ V}$, $T_A = 25^\circ\text{C}$

PARAMETER		TEST CONDITIONS	TYP	UNIT
C_{pd}	Power dissipation capacitance per transceiver	Outputs enabled	39.5	pF
		Outputs disabled	5	

Power-Up Considerations⁽¹⁾

TI level-translation devices offer an opportunity for successful mixed-voltage signal design. A proper power-up sequence always should be followed to avoid excessive supply current, bus contention, oscillations, or other anomalies caused by improperly biased device pins. Take these precautions to guard against such power-up problems:

1. Connect ground before any supply voltage is applied.
2. Power up the control side of the device (V_{CCA} for all four of these devices).
3. Tie \overline{OE} to V_{CCA} with a pullup resistor so that it ramps with V_{CCA} .
4. Depending on the direction of the data path, DIR can be high or low. If DIR high is needed (A data to B bus), ramp it with V_{CCA} . Otherwise, keep DIR low.

(1) Refer to the TI application report, *Texas Instruments Voltage-Level-Translation Devices*, literature number SCEA021.

勝特力材料 886-3-5753170
 勝特力电子(上海) 86-21-34970699
 勝特力电子(深圳) 86-755-83298787
[Http://www.100y.com.tw](http://www.100y.com.tw)

PARAMETER MEASUREMENT INFORMATION
A PORT

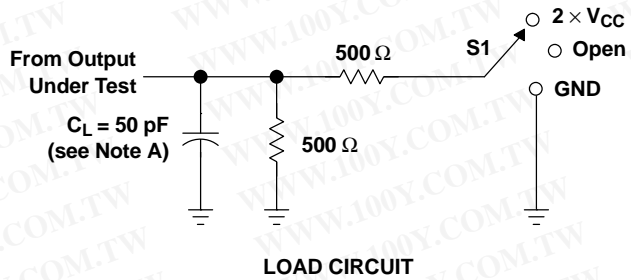

TEST	S1
t_{PLH}/t_{PHL}	Open
t_{PLZ}/t_{PZL}	$2 \times V_{CC}$
t_{PHZ}/t_{PZH}	GND

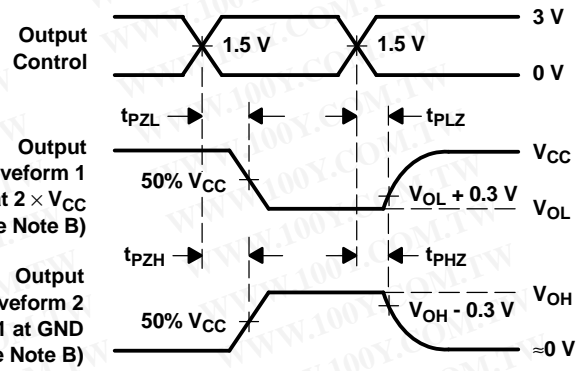
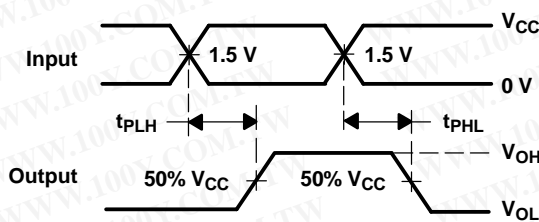
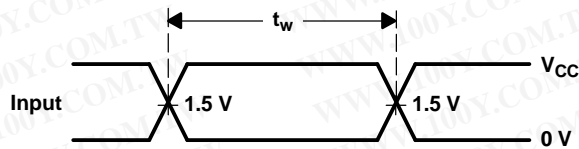

- NOTES: A. C_L includes probe and jig capacitance.
 B. Waveform 1 is for an output with internal conditions such that the output is low, except when disabled by the output control. Waveform 2 is for an output with internal conditions such that the output is high, except when disabled by the output control.
 C. All input pulses are supplied by generators having the following characteristics: $PRR \leq 10 \text{ MHz}$, $Z_O = 50 \Omega$, $t_r \leq 2.5 \text{ ns}$, $t_f \leq 2.5 \text{ ns}$.
 D. The outputs are measured one at a time, with one transition per measurement.
 E. All parameters and waveforms are not applicable to all devices.

Figure 1. Load Circuit and Voltage Waveforms

勝特力材料 886-3-5753170
 勝特力电子(上海) 86-21-34970699
 勝特力电子(深圳) 86-755-83298787
[Http://www.100y.com.tw](http://www.100y.com.tw)

PARAMETER MEASUREMENT INFORMATION
B PORT

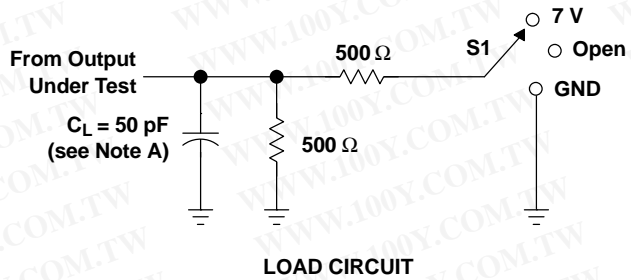

TEST	S1
t_{PLH}/t_{PHL}	Open
t_{PLZ}/t_{PZL}	7 V
t_{PHZ}/t_{PZH}	GND

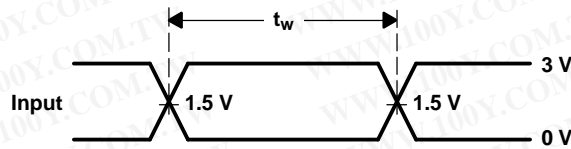

VOLTAGE WAVEFORMS
PULSE DURATION

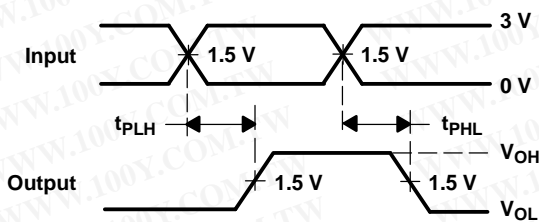

VOLTAGE WAVEFORMS
PROPAGATION DELAY TIMES
NONINVERTING OUTPUTS

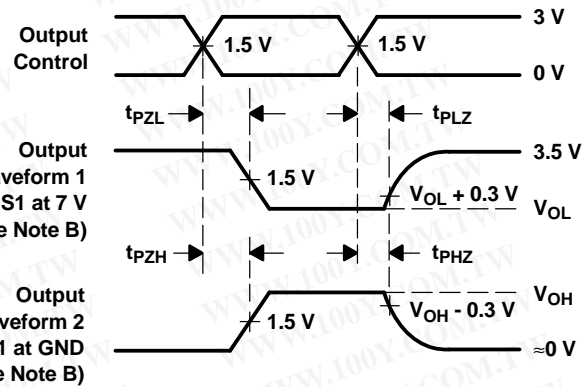

VOLTAGE WAVEFORMS
ENABLE AND DISABLE TIMES
LOW- AND HIGH-LEVEL ENABLING

- NOTES: A. C_L includes probe and jig capacitance.
 B. Waveform 1 is for an output with internal conditions such that the output is low, except when disabled by the output control. Waveform 2 is for an output with internal conditions such that the output is high, except when disabled by the output control.
 C. All input pulses are supplied by generators having the following characteristics: $PRR \leq 10$ MHz, $Z_O = 50 \Omega$, $t_r \leq 2.5$ ns, $t_f \leq 2.5$ ns.
 D. The outputs are measured one at a time, with one transition per measurement.
 E. All parameters and waveforms are not applicable to all devices.

Figure 2. Load Circuit and Voltage Waveforms

勝特力材料 886-3-5753170
 勝特力电子(上海) 86-21-34970699
 勝特力电子(深圳) 86-755-83298787
[Http://www.100y.com.tw](http://www.100y.com.tw)

PACKAGING INFORMATION

Orderable Device	Status ⁽¹⁾	Package Type	Package Drawing	Pins	Package Qty	Eco Plan ⁽²⁾	Lead/Ball Finish	MSL Peak Temp ⁽³⁾
SN74LVC4245ADBR	ACTIVE	SSOP	DB	24	2000	Green (RoHS & no Sb/Br)	CU NIPDAU	Level-1-260C-UNLIM
SN74LVC4245ADBRE4	ACTIVE	SSOP	DB	24	2000	Green (RoHS & no Sb/Br)	CU NIPDAU	Level-1-260C-UNLIM
SN74LVC4245ADBRG4	ACTIVE	SSOP	DB	24	2000	Green (RoHS & no Sb/Br)	CU NIPDAU	Level-1-260C-UNLIM
SN74LVC4245ADW	ACTIVE	SOIC	DW	24	25	Green (RoHS & no Sb/Br)	CU NIPDAU	Level-1-260C-UNLIM
SN74LVC4245ADWE4	ACTIVE	SOIC	DW	24	25	Green (RoHS & no Sb/Br)	CU NIPDAU	Level-1-260C-UNLIM
SN74LVC4245ADWG4	ACTIVE	SOIC	DW	24	25	Green (RoHS & no Sb/Br)	CU NIPDAU	Level-1-260C-UNLIM
SN74LVC4245ADWR	ACTIVE	SOIC	DW	24	2000	Green (RoHS & no Sb/Br)	CU NIPDAU	Level-1-260C-UNLIM
SN74LVC4245ADWRE4	ACTIVE	SOIC	DW	24	2000	Green (RoHS & no Sb/Br)	CU NIPDAU	Level-1-260C-UNLIM
SN74LVC4245ADWRG4	ACTIVE	SOIC	DW	24	2000	Green (RoHS & no Sb/Br)	CU NIPDAU	Level-1-260C-UNLIM
SN74LVC4245APW	ACTIVE	TSSOP	PW	24	60	Green (RoHS & no Sb/Br)	CU NIPDAU	Level-1-260C-UNLIM
SN74LVC4245APWE4	ACTIVE	TSSOP	PW	24	60	Green (RoHS & no Sb/Br)	CU NIPDAU	Level-1-260C-UNLIM
SN74LVC4245APWG4	ACTIVE	TSSOP	PW	24	60	Green (RoHS & no Sb/Br)	CU NIPDAU	Level-1-260C-UNLIM
SN74LVC4245APWR	ACTIVE	TSSOP	PW	24	2000	Green (RoHS & no Sb/Br)	CU NIPDAU	Level-1-260C-UNLIM
SN74LVC4245APWRE4	ACTIVE	TSSOP	PW	24	2000	Green (RoHS & no Sb/Br)	CU NIPDAU	Level-1-260C-UNLIM
SN74LVC4245APWRG4	ACTIVE	TSSOP	PW	24	2000	Green (RoHS & no Sb/Br)	CU NIPDAU	Level-1-260C-UNLIM
SN74LVC4245APWT	ACTIVE	TSSOP	PW	24	250	Green (RoHS & no Sb/Br)	CU NIPDAU	Level-1-260C-UNLIM
SN74LVC4245APWTE4	ACTIVE	TSSOP	PW	24	250	Green (RoHS & no Sb/Br)	CU NIPDAU	Level-1-260C-UNLIM
SN74LVC4245APWTG4	ACTIVE	TSSOP	PW	24	250	Green (RoHS & no Sb/Br)	CU NIPDAU	Level-1-260C-UNLIM

⁽¹⁾ The marketing status values are defined as follows:

ACTIVE: Product device recommended for new designs.

LIFEBUY: TI has announced that the device will be discontinued, and a lifetime-buy period is in effect.

NRND: Not recommended for new designs. Device is in production to support existing customers, but TI does not recommend using this part in a new design.

PREVIEW: Device has been announced but is not in production. Samples may or may not be available.

OBsolete: TI has discontinued the production of the device.

⁽²⁾ Eco Plan - The planned eco-friendly classification: Pb-Free (RoHS), Pb-Free (RoHS Exempt), or Green (RoHS & no Sb/Br) - please check for the latest availability information and additional product content details.

TBD: The Pb-Free/Green conversion plan has not been defined.

Pb-Free (RoHS): TI's terms "Lead-Free" or "Pb-Free" mean semiconductor products that are compatible with the current RoHS requirements for all 6 substances, including the requirement that lead not exceed 0.1% by weight in homogeneous materials. Where designed to be soldered at high temperatures, TI Pb-Free products are suitable for use in specified lead-free processes.

Pb-Free (RoHS Exempt): This component has a RoHS exemption for either 1) lead-based flip-chip solder bumps used between the die and

package, or 2) lead-based die adhesive used between the die and leadframe. The component is otherwise considered Pb-Free (RoHS compatible) as defined above.

Green (RoHS & no Sb/Br): TI defines "Green" to mean Pb-Free (RoHS compatible), and free of Bromine (Br) and Antimony (Sb) based flame retardants (Br or Sb do not exceed 0.1% by weight in homogeneous material)

(3) MSL, Peak Temp. -- The Moisture Sensitivity Level rating according to the JEDEC industry standard classifications, and peak solder temperature.

Important Information and Disclaimer:The information provided on this page represents TI's knowledge and belief as of the date that it is provided. TI bases its knowledge and belief on information provided by third parties, and makes no representation or warranty as to the accuracy of such information. Efforts are underway to better integrate information from third parties. TI has taken and continues to take reasonable steps to provide representative and accurate information but may not have conducted destructive testing or chemical analysis on incoming materials and chemicals. TI and TI suppliers consider certain information to be proprietary, and thus CAS numbers and other limited information may not be available for release.

In no event shall TI's liability arising out of such information exceed the total purchase price of the TI part(s) at issue in this document sold by TI to Customer on an annual basis.

OTHER QUALIFIED VERSIONS OF SN74LVC4245A :

- Enhanced Product:

NOTE: Qualified Version Definitions:

- Enhanced Product - Supports Defense, Aerospace and Medical Applications

勝特力材料 886-3-5753170
勝特力电子(上海) 86-21-34970699
勝特力电子(深圳) 86-755-83298787
[Http://www.100y.com.tw](http://www.100y.com.tw)

TAPE AND REEL INFORMATION

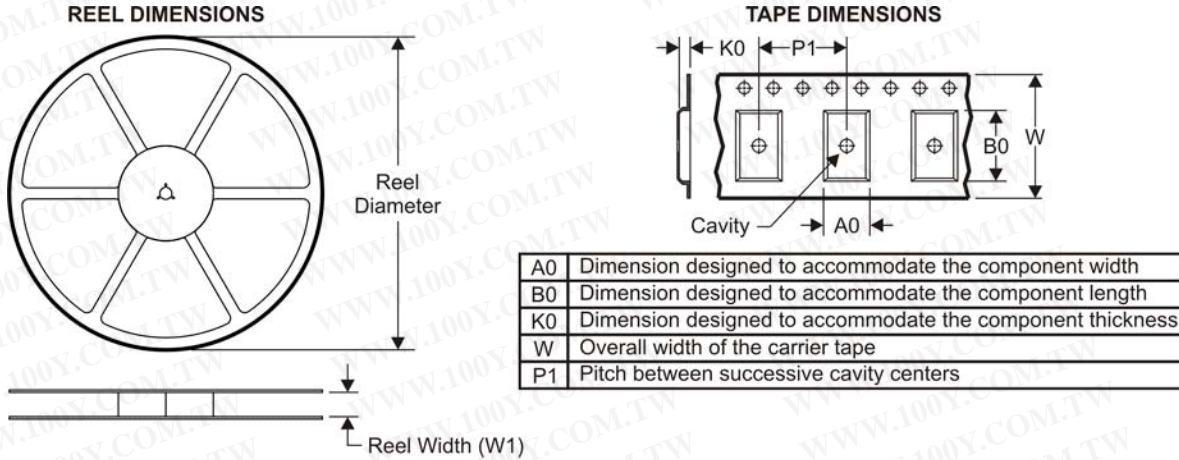

QUADRANT ASSIGNMENTS FOR PIN 1 ORIENTATION IN TAPE

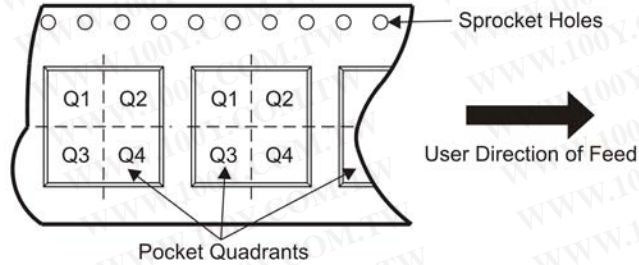

*All dimensions are nominal

Device	Package Type	Package Drawing	Pins	SPQ	Reel Diameter (mm)	Reel Width W1 (mm)	A0 (mm)	B0 (mm)	K0 (mm)	P1 (mm)	W (mm)	Pin1 Quadrant
SN74LVC4245ADBR	SSOP	DB	24	2000	330.0	16.4	8.2	8.8	2.5	12.0	16.0	Q1
SN74LVC4245ADWR	SOIC	DW	24	2000	330.0	24.4	10.75	15.7	2.7	12.0	24.0	Q1
SN74LVC4245APWR	TSSOP	PW	24	2000	330.0	16.4	6.95	8.3	1.6	8.0	16.0	Q1

勝特力材料 886-3-5753170
 勝特力电子(上海) 86-21-34970699
 勝特力电子(深圳) 86-755-83298787
[Http://www.100y.com.tw](http://www.100y.com.tw)

TAPE AND REEL BOX DIMENSIONS

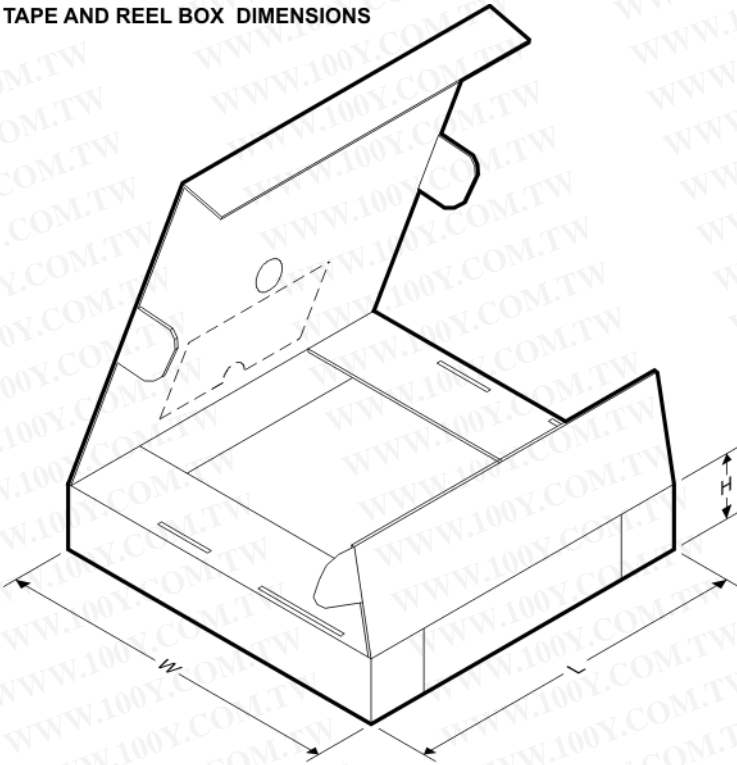

*All dimensions are nominal

Device	Package Type	Package Drawing	Pins	SPQ	Length (mm)	Width (mm)	Height (mm)
SN74LVC4245ADBR	SSOP	DB	24	2000	346.0	346.0	33.0
SN74LVC4245ADWR	SOIC	DW	24	2000	346.0	346.0	41.0
SN74LVC4245APWR	TSSOP	PW	24	2000	346.0	346.0	33.0

勝特力材料 886-3-5753170
 勝特力电子(上海) 86-21-34970699
 勝特力电子(深圳) 86-755-83298787
[Http://www.100y.com.tw](http://www.100y.com.tw)

DB (R-PDSO-G**)

PLASTIC SMALL-OUTLINE

28 PINS SHOWN

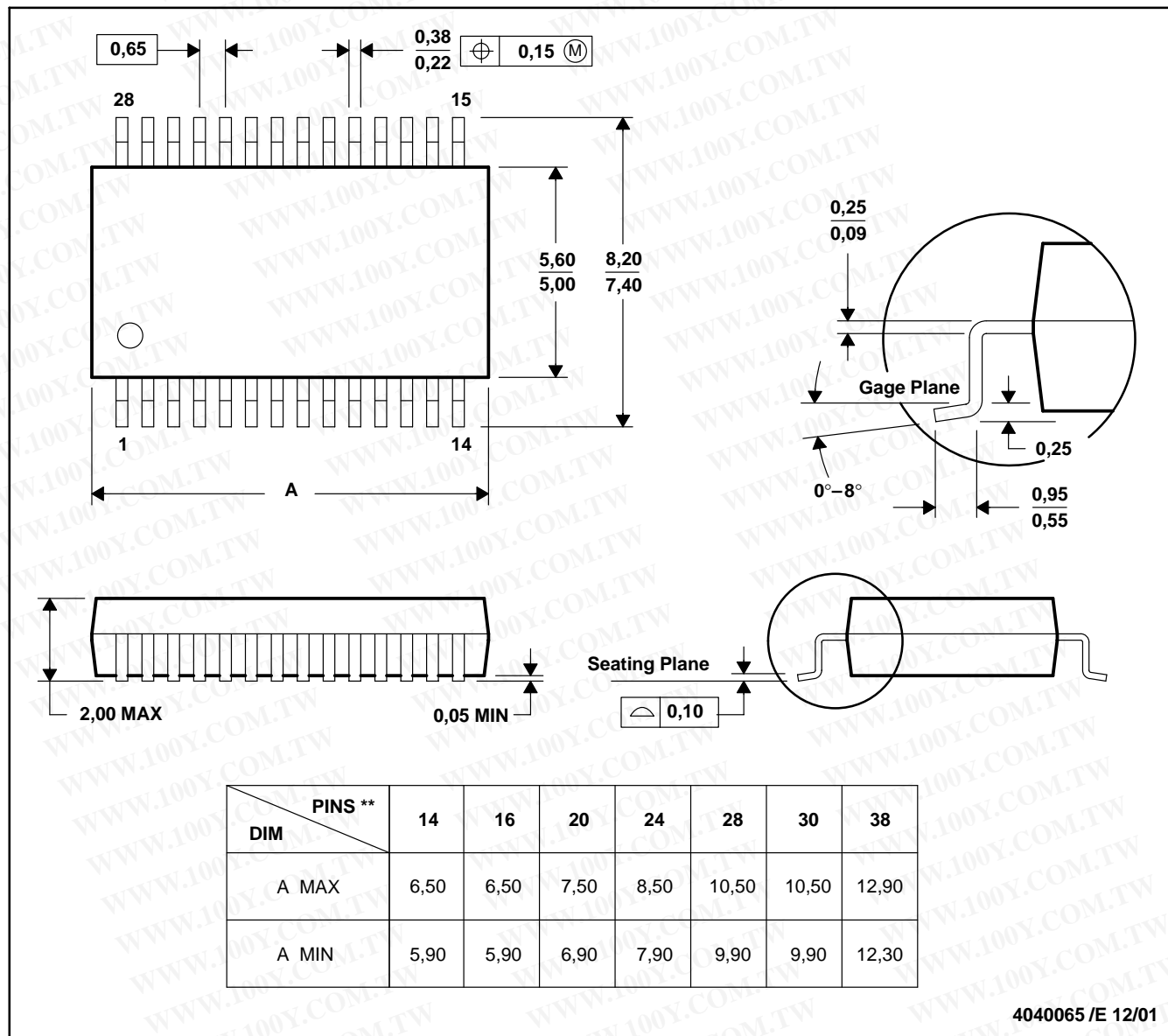

- NOTES: A. All linear dimensions are in millimeters.
 B. This drawing is subject to change without notice.
 C. Body dimensions do not include mold flash or protrusion not to exceed 0,15.
 D. Falls within JEDEC MO-150

勝特力材料 86-3-5753170
 勝特力电子(上海) 86-21-34970699
 勝特力电子(深圳) 86-755-83298787
[Http://www.100y.com.tw](http://www.100y.com.tw)

PW (R-PDSO-G**)

PLASTIC SMALL-OUTLINE PACKAGE

14 PINS SHOWN

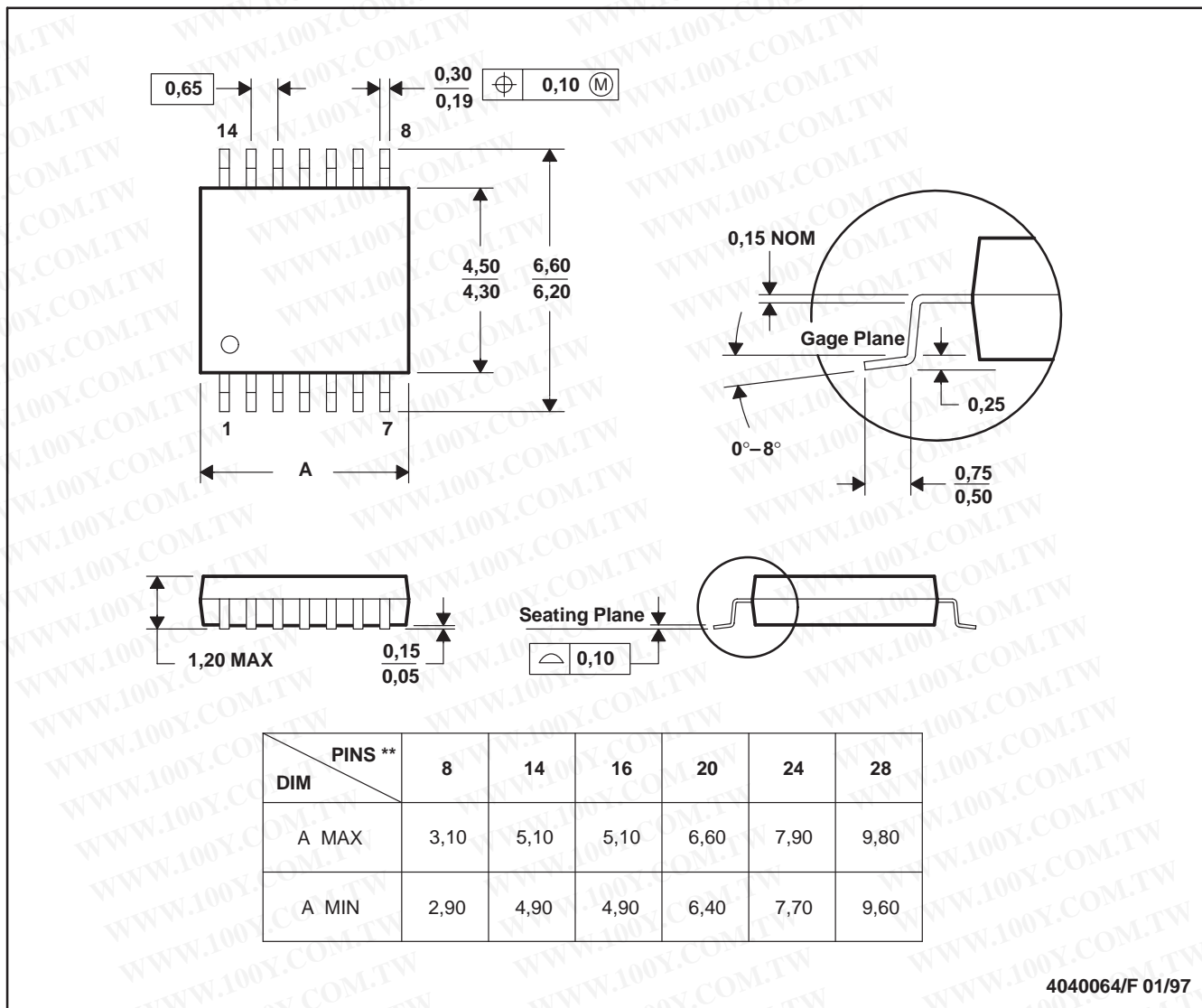

- NOTES: A. All linear dimensions are in millimeters.
 B. This drawing is subject to change without notice.
 C. Body dimensions do not include mold flash or protrusion not to exceed 0,15.
 D. Falls within JEDEC MO-153

勝特力材料 886-3-5753170
 勝特力电子(上海) 86-21-34970699
 勝特力电子(深圳) 86-755-83298787
[Http://www.100y.com.tw](http://www.100y.com.tw)

DW (R-PDSO-G24)

PLASTIC SMALL-OUTLINE PACKAGE

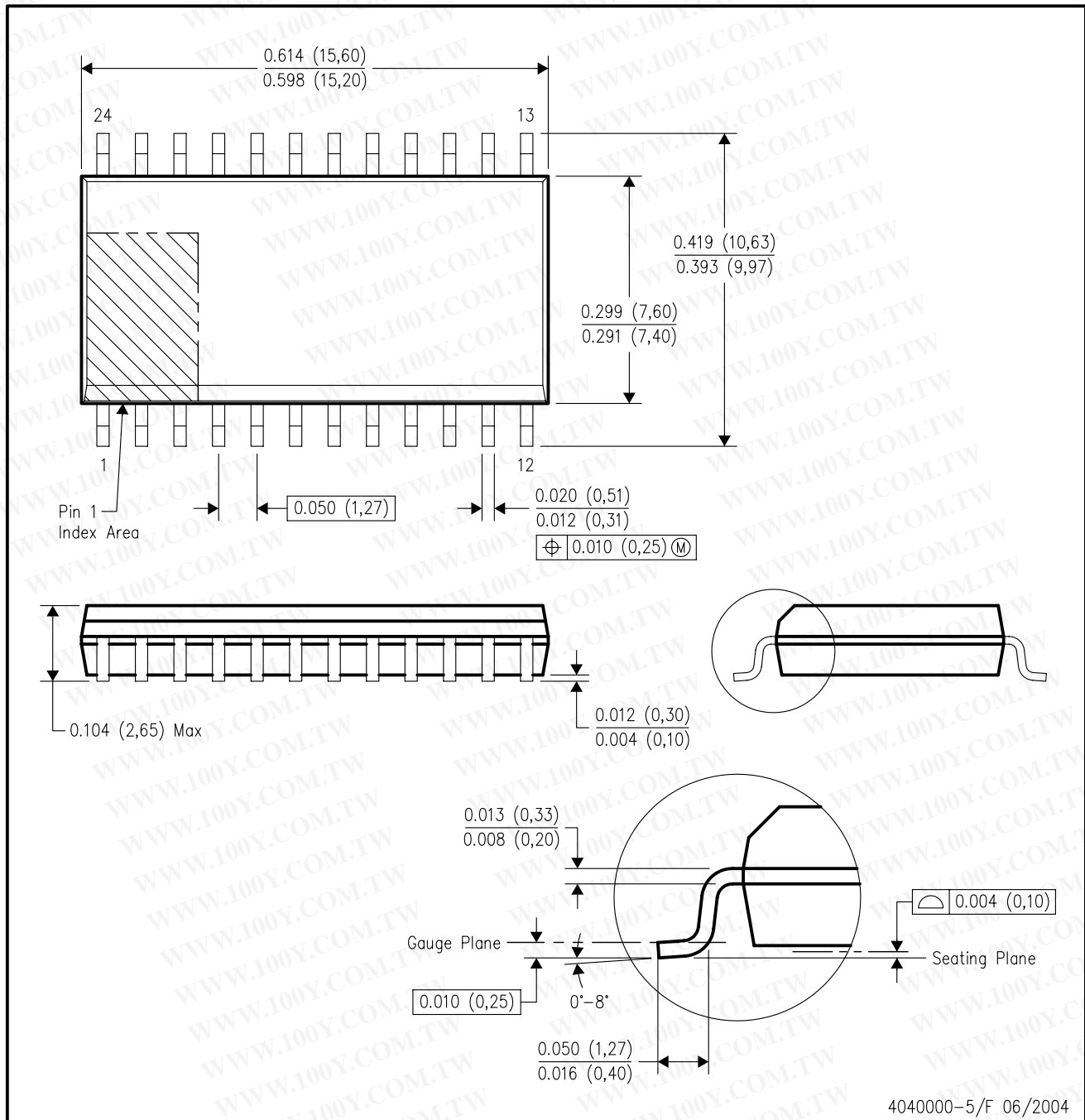

- NOTES:
- All linear dimensions are in inches (millimeters).
 - This drawing is subject to change without notice.
 - Body dimensions do not include mold flash or protrusion not to exceed 0.006 (0,15).
 - Falls within JEDEC MS-013 variation AD.