

TOSHIBA CMOS Digital Integrated Circuit Silicon Monolithic

# TC4028BP, TC4028BF, TC4028BFN

## TC4028B BCD-to-Decimal Decoder

TC4028B is a BCD-to-DECIMAL decoder which converts BCD signal into DECIMAL signal.

Of ten outputs from Q0 to Q9, one output corresponding to input BCD code goes to the "H" level and all the others remain at the "L" level.

When D is used as inhibit input by use of three input lines from A to C, this decoder can be served as a BINARY-to-OCTAL decoder.

### Pin Assignment

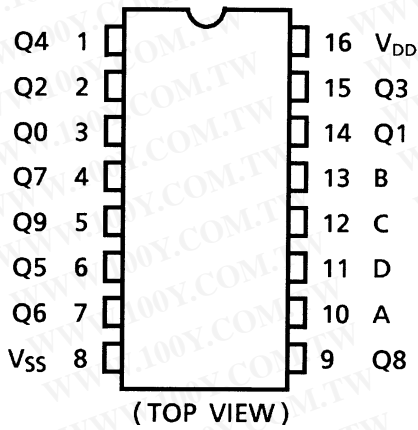

Note: xxxFN (JEDEC SOP) is not available in Japan.

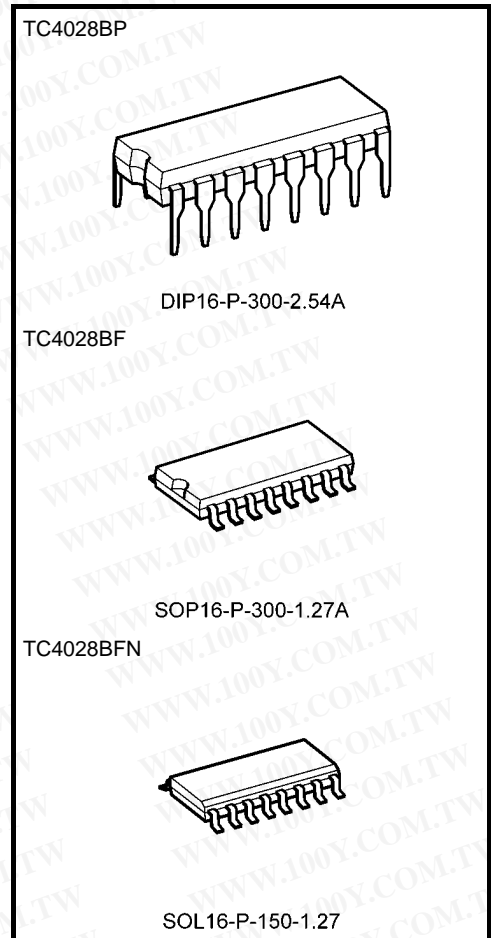

Weight	
DIP16-P-300-2.54A	: 1.00 g (typ.)
SOP16-P-300-1.27A	: 0.18 g (typ.)
SOL16-P-150-1.27	: 0.13 g (typ.)

勝特力材料 886-3-5753170  
 勝特力电子(上海) 86-21-34970699  
 勝特力电子(深圳) 86-755-83298787  
[Http://www.100y.com.tw](http://www.100y.com.tw)

## Truth Table

Inputs				Outputs									
D	C	B	A	Q0	Q1	Q2	Q3	Q4	Q5	Q6	Q7	Q8	Q9
L	L	L	L	H	L	L	L	L	L	L	L	L	L
L	L	L	H	L	H	L	L	L	L	L	L	L	L
L	L	H	L	L	L	H	L	L	L	L	L	L	L
L	L	H	H	L	L	L	H	L	L	L	L	L	L
L	H	L	L	L	L	L	L	H	L	L	L	L	L
L	H	L	H	L	L	L	L	L	H	L	L	L	L
L	H	H	L	L	L	L	L	L	L	H	L	L	L
L	H	H	H	L	L	L	L	L	L	L	H	L	L
H	L	L	L	L	L	L	L	L	L	L	L	H	L
H	L	L	H	L	L	L	L	L	L	L	L	L	H
H	L	H	L	L	L	L	L	L	L	L	L	L	L
H	L	H	H	L	L	L	L	L	L	L	L	L	L
H	H	L	L	L	L	L	L	L	L	L	L	L	L
H	H	L	H	L	L	L	L	L	L	L	L	L	L
H	H	H	L	L	L	L	L	L	L	L	L	L	L
H	H	H	H	L	L	L	L	L	L	L	L	L	L

H = High level

L = Low level

## Logic Diagram

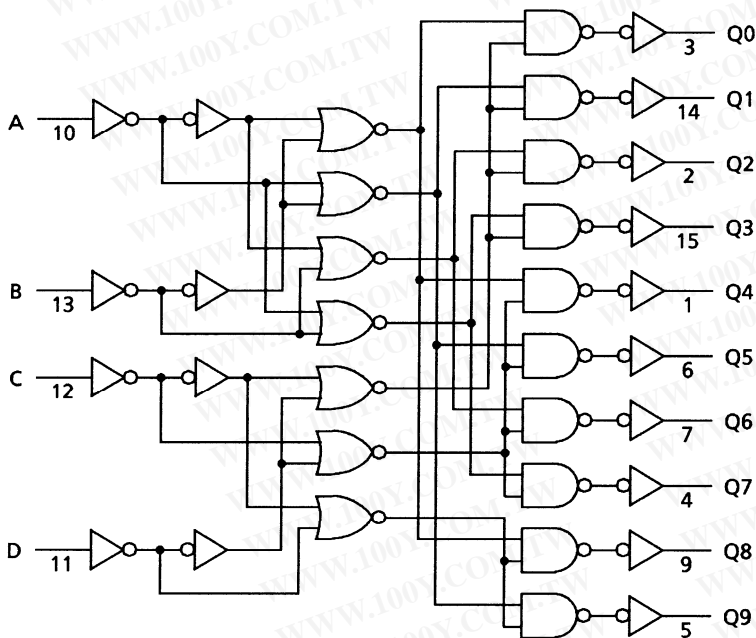

## Absolute Maximum Ratings (Note)

Characteristics	Symbol	Rating	Unit
DC supply voltage	$V_{DD}$	$V_{SS} - 0.5$ to $V_{SS} + 20$	V
Input voltage	$V_{IN}$	$V_{SS} - 0.5$ to $V_{DD} + 0.5$	V
Output voltage	$V_{OUT}$	$V_{SS} - 0.5$ to $V_{DD} + 0.5$	V
DC input current	$I_{IN}$	$\pm 10$	mA
Power dissipation	$P_D$	300 (DIP)/180 (SOIC)	mW
Operating temperature range	$T_{opr}$	-40 to 85	°C
Storage temperature range	$T_{stg}$	-65 to 150	°C

Note: Exceeding any of the absolute maximum ratings, even briefly, lead to deterioration in IC performance or even destruction.

Using continuously under heavy loads (e.g. the application of high temperature/current/voltage and the significant change in temperature, etc.) may cause this product to decrease in the reliability significantly even if the operating conditions (i.e. operating temperature/current/voltage, etc.) are within the absolute maximum ratings and the operating ranges.

Please design the appropriate reliability upon reviewing the Toshiba Semiconductor Reliability Handbook ("Handling Precautions"/"Derating Concept and Methods") and individual reliability data (i.e. reliability test report and estimated failure rate, etc.).

## Operating Ranges ( $V_{SS} = 0$ V) (Note)

Characteristics	Symbol	Test Condition	Min	Typ.	Max	Unit
DC supply voltage	$V_{DD}$	—	3	—	18	V
Input voltage	$V_{IN}$	—	0	—	$V_{DD}$	V

Note: The operating ranges must be maintained to ensure the normal operation of the device.  
Unused inputs must be tied to either  $V_{DD}$  or  $V_{SS}$ .

## Static Electrical Characteristics (V<sub>SS</sub> = 0 V)

Characteristics	Sym- bol	Test Condition	V <sub>DD</sub> (V)	-40°C		25°C			85°C		Unit	
				Min	Max	Min	Typ.	Max	Min	Max		
High-level output voltage	V <sub>OH</sub>	I <sub>OUT</sub>   < 1 μA V <sub>IN</sub> = V <sub>SS</sub> , V <sub>DD</sub>	5	4.95	—	4.95	5.00	—	4.95	—	V	
			10	9.95	—	9.95	10.00	—	9.95	—		
			15	14.95	—	14.95	15.00	—	14.95	—		
Low-level output voltage	V <sub>OL</sub>	I <sub>OUT</sub>   < 1 μA V <sub>IN</sub> = V <sub>SS</sub> , V <sub>DD</sub>	5	—	0.05	—	0.00	0.05	—	0.05	V	
			10	—	0.05	—	0.00	0.05	—	0.05		
			15	—	0.05	—	0.00	0.05	—	0.05		
Output high current	I <sub>OH</sub>	V <sub>OH</sub> = 4.6 V V <sub>OH</sub> = 2.5 V V <sub>OH</sub> = 9.5 V V <sub>OH</sub> = 13.5 V V <sub>IN</sub> = V <sub>SS</sub> , V <sub>DD</sub>	5	-0.61	—	-0.51	-1.0	—	-0.42	—	mA	
			5	-2.50	—	-2.10	-4.0	—	-1.70	—		
			10	-1.50	—	-1.30	-2.2	—	-1.10	—		
			15	-4.00	—	-3.40	-9.0	—	-2.80	—		
Output low current	I <sub>OL</sub>	V <sub>OL</sub> = 0.4 V V <sub>OL</sub> = 0.5 V V <sub>OL</sub> = 1.5 V V <sub>IN</sub> = V <sub>SS</sub> , V <sub>DD</sub>	5	0.61	—	0.51	1.2	—	0.42	—	mA	
			10	1.50	—	1.30	3.2	—	1.10	—		
			15	4.00	—	3.40	12.0	—	2.80	—		
Input high voltage	V <sub>IH</sub>	V <sub>OUT</sub> = 0.5 V, 4.5 V V <sub>OUT</sub> = 1.0 V, 9.0 V V <sub>OUT</sub> = 1.5 V, 13.5 V  I <sub>OUT</sub>   < 1 μA	5	3.5	—	3.5	2.75	—	3.5	—	V	
			10	7.0	—	7.0	5.50	—	7.0	—		
			15	11.0	—	11.0	8.25	—	11.0	—		
Input low voltage	V <sub>IL</sub>	V <sub>OUT</sub> = 0.5 V, 4.5 V V <sub>OUT</sub> = 1.0 V, 9.0 V V <sub>OUT</sub> = 1.5 V, 13.5 V  I <sub>OUT</sub>   < 1 μA	5	—	1.5	—	2.25	1.5	—	1.5	V	
			10	—	3.0	—	4.50	3.0	—	3.0		
			15	—	4.0	—	6.75	4.0	—	4.0		
Input current	"H" level	I <sub>IH</sub>	V <sub>IH</sub> = 18 V	18	—	0.1	—	10 <sup>-5</sup>	0.1	—	1.0	μA
	"L" level	I <sub>IL</sub>	V <sub>IL</sub> = 0 V	18	—	-0.1	—	-10 <sup>-5</sup>	-0.1	—	-1.0	
Quiescent supply current	I <sub>DD</sub>	V <sub>IN</sub> = V <sub>SS</sub> , V <sub>DD</sub> (Note)	5	—	5	—	0.005	5	—	150	μA	
			10	—	10	—	0.010	10	—	300		
			15	—	20	—	0.015	20	—	600		

Note: All valid input combinations.

## Dynamic Electrical Characteristics (Ta = 25°C, VSS = 0 V, CL = 50 pF)

Characteristics	Symbol	Test Condition	VDD (V)	Min	Typ.	Max	Unit
Output transition time (low to high)	t <sub>TLH</sub>	—	5	—	70	200	ns
			10	—	35	100	
			15	—	30	80	
Output transition time (high to low)	t <sub>THL</sub>	—	5	—	70	200	ns
			10	—	35	100	
			15	—	30	80	
Propagation delay time	t <sub>pLH</sub> t <sub>pHL</sub>	—	5	—	110	350	ns
			10	—	55	160	
			15	—	40	120	
Input capacitance	C <sub>IN</sub>	—	—	5	7.5	pF	

### Waveform for Measurement of Dynamic Characteristics

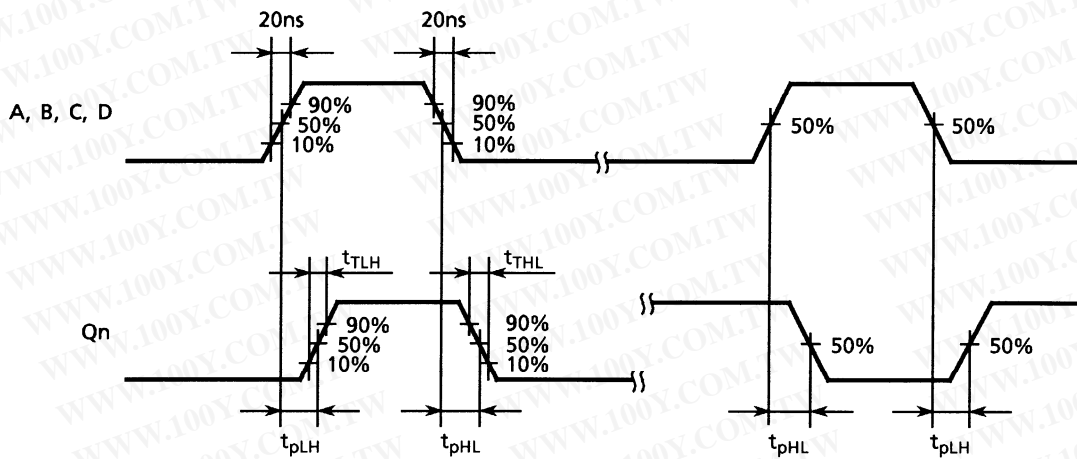

## Package Dimensions

DIP16-P-300-2.54A

Unit : mm

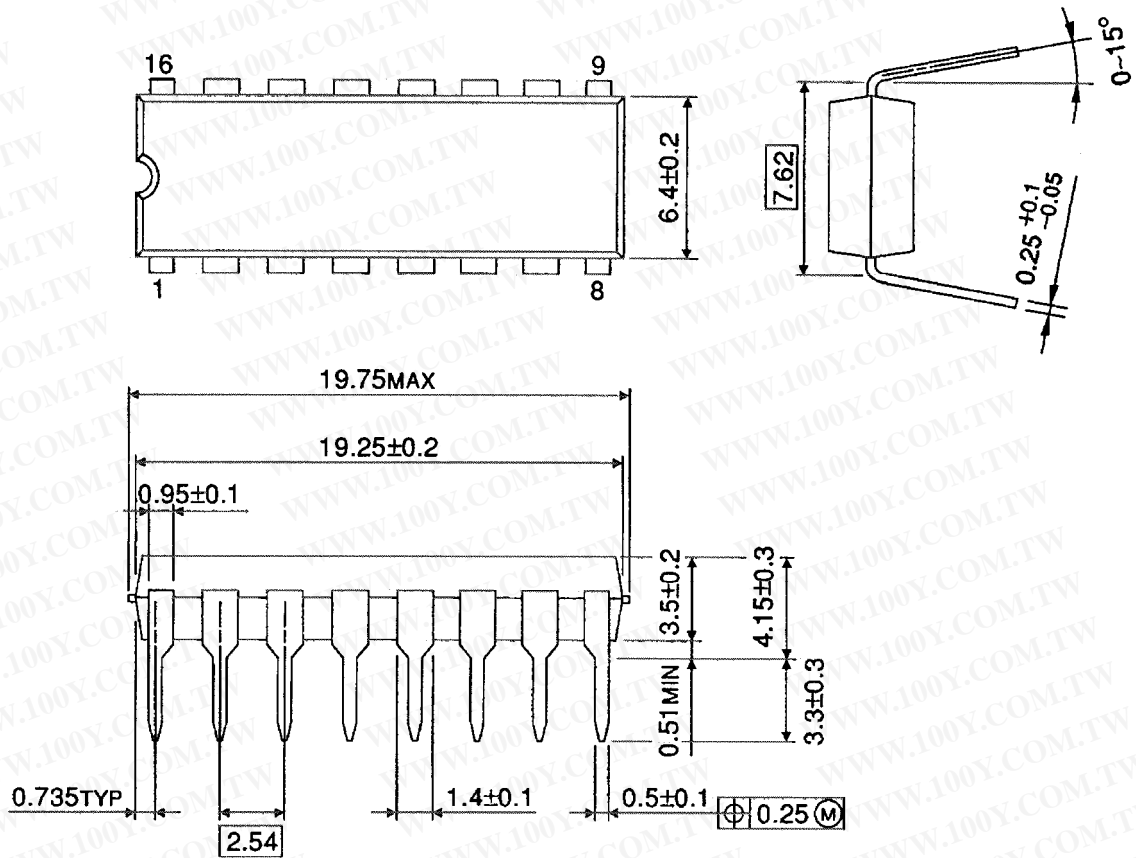

Weight: 1.00 g (typ.)

## Package Dimensions

SOP16-P-300-1.27A

Unit: mm

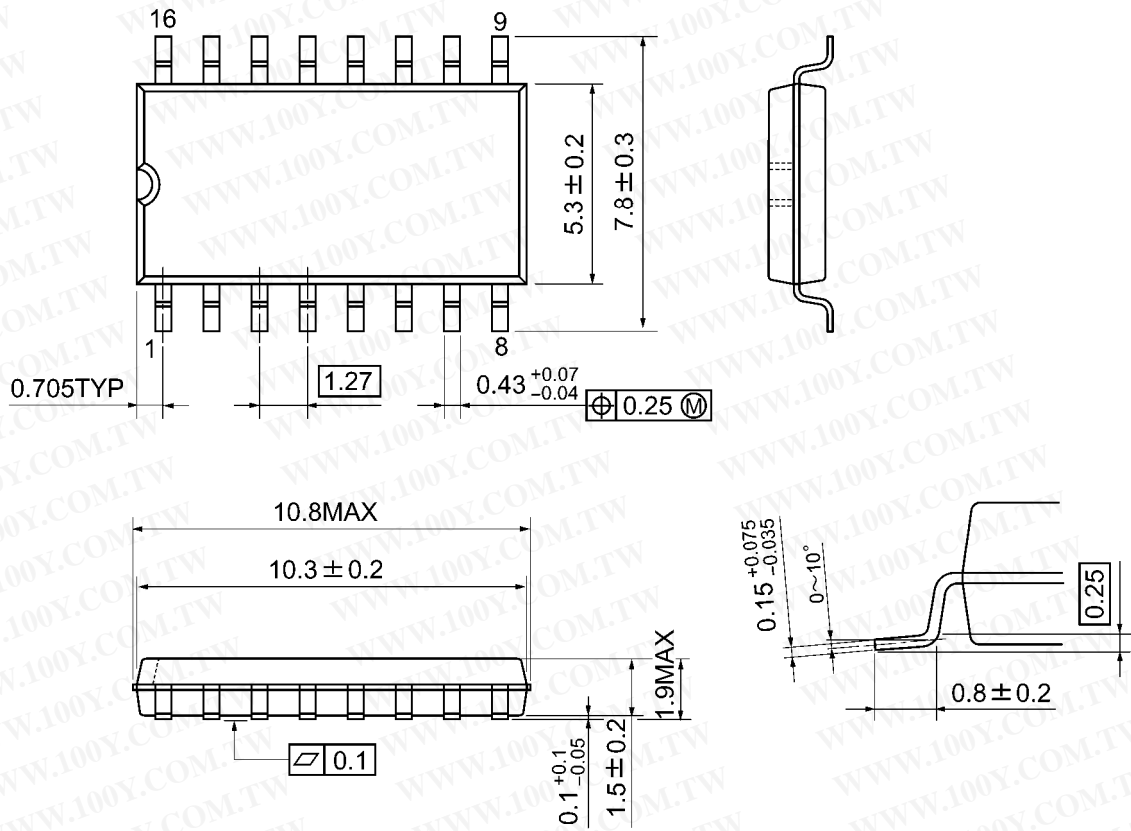

Weight: 0.18 g (typ.)

## Package Dimensions (Note)

SOL16-P-150-1.27

Unit : mm

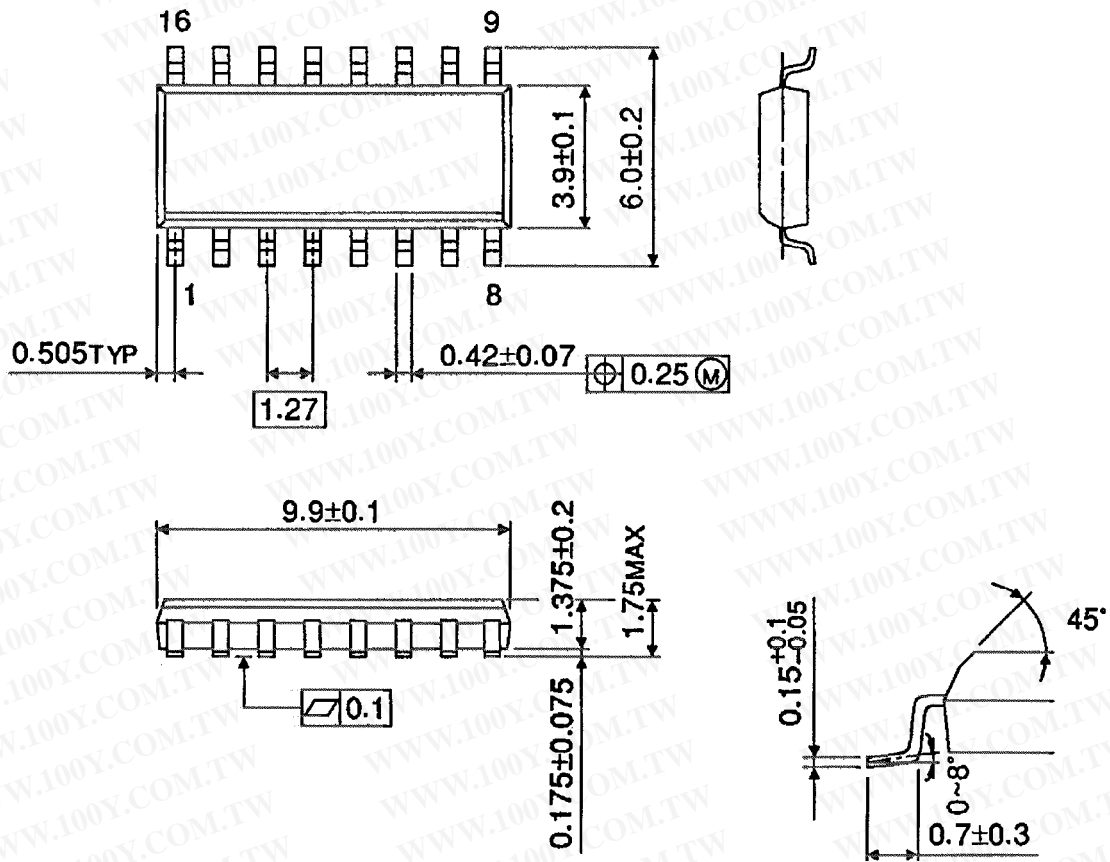

Note: This package is not available in Japan.

Weight: 0.13 g (typ.)

勝特力材料 886-3-5753170  
 勝特力电子(上海) 86-21-34970699  
 勝特力电子(深圳) 86-755-83298787  
[Http://www.100y.com.tw](http://www.100y.com.tw)