



勝特力材料 886-3-5753170
勝特力电子(上海) 86-21-34970699
勝特力电子(深圳) 86-755-83298787
[Http://www.100y.com.tw](http://www.100y.com.tw)

MC78XXE 3-Terminal 1A Positive Voltage Regulator

Features

- Output Current up to 1 A
- Output Voltages of 5 V, 12 V
- Thermal Overload Protection
- Short-Circuit Protection
- Output Transistor Safe Operating Area Protection

Description

The MC78XXE series of three terminal positive regulators are available in the D-PAK package and with several fixed output voltages, making them useful in a wide range of applications. Each type employs internal current limiting, thermal shut down and safe operating area protection, making it essentially indestructible. If adequate heat sinking is provided, they can deliver over 1 A output current. Although designed primarily as fixed voltage regulators, these devices can be used with external components to obtain adjustable voltages and currents.

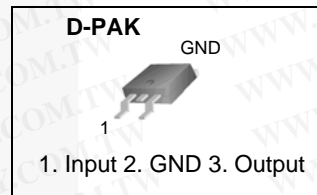

Ordering Information

Product Number	Marking	Package	Packing Method	Output Voltage Tolerance	Operating Temperature
MC7805ECDTX	MC7805	TO-252 3L (D-PAK)	Tape and Reel	±4%	-40 to +125°C
MC7812ECDTX	MC7812	TO-252 3L (D-PAK)	Tape and Reel		

Block Diagram

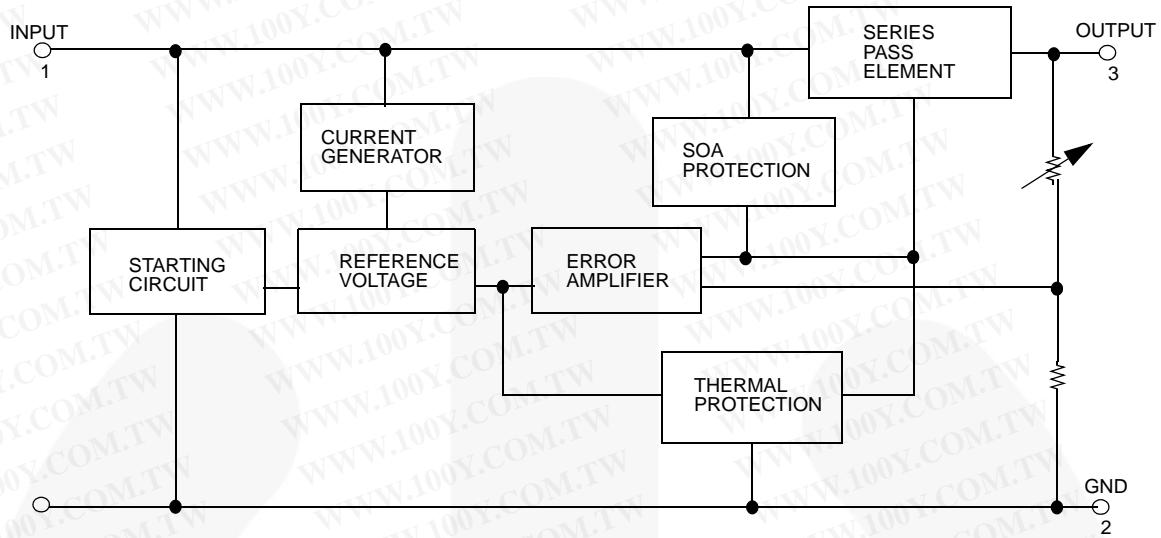

Figure 1. Block Diagram

Absolute Maximum Ratings

Stresses exceeding the absolute maximum ratings may damage the device. The device may not function or be operable above the recommended operating conditions and stressing the parts to these levels is not recommended. In addition, extended exposure to stresses above the recommended operating conditions may affect device reliability. The absolute maximum ratings are stress ratings only. Values are at $T_A = 25^\circ\text{C}$ unless otherwise noted.

Symbol	Parameter		Value	Unit
V_I	Input Voltage	$V_O = 5\text{ V to }18\text{ V}$	35	V
T_{OPR}	Operating Temperature Range		-40 to +125	$^\circ\text{C}$
T_{STG}	Storage Temperature Range		-65 to +150	$^\circ\text{C}$

Electrical Characteristics (MC7805E)

Refer to test circuit, $-40^{\circ}\text{C} < T_J < 125^{\circ}\text{C}$, $I_O = 500\text{ mA}$, $V_I = 10\text{ V}$, $C_I = 0.33\text{ }\mu\text{F}$, $C_O = 0.1\text{ }\mu\text{F}$, unless otherwise specified.

Symbol	Parameter	Conditions	Min.	Typ.	Max.	Unit
V_O	Output Voltage	$T_J = +25^{\circ}\text{C}$	4.80	5.00	5.20	V
		$5.0\text{ mA } I_O \text{ 1.0 A, } P_O \text{ 15 W, } V_I = 7\text{ V to } 20\text{ V}$	4.75	5.00	5.25	
Regline	Line Regulation ⁽¹⁾	$T_J = +25^{\circ}\text{C}$	$V_I = 7\text{ V to } 25\text{ V}$	4	100	mV
			$V_I = 8\text{ V to } 12\text{ V}$	1.6	50	
Regload	Load Regulation ⁽¹⁾	$T_J = +25^{\circ}\text{C}$	$I_O = 5.0\text{ mA to } 1.5\text{ A}$	9	100	mV
			$I_O = 250\text{ mA to } 750\text{ mA}$	4	50	
I_Q	Quiescent Current	$T_J = +25^{\circ}\text{C}$		5	8	mA
ΔI_Q	Quiescent Current Change	$I_O = 5\text{ mA to } 1.0\text{ A}$		0.03	0.50	mA
			$V_I = 7\text{ V to } 25\text{ V}$	0.3	1.3	
$\Delta V_O/\Delta T$	Output Voltage Drift ⁽²⁾	$I_O = 5\text{ mA}$		-0.8		mV/ $^{\circ}\text{C}$
V_N	Output Noise Voltage	$f = 10\text{ Hz to } 100\text{ kHz, } T_A = +25^{\circ}\text{C}$		42		μV
RR	Ripple Rejection ⁽²⁾	$f = 120\text{ Hz, } V_O = 8\text{ V to } 18\text{ V}$	62	73		dB
V_{Drop}	Dropout Voltage	$I_O = 1\text{ A, } T_J = +25^{\circ}\text{C}$		2		V
r_O	Output Resistance ⁽²⁾	$f = 1\text{ kHz}$		15		m Ω
I_{SC}	Short Circuit Current	$V_I = 35\text{ V, } T_A = +25^{\circ}\text{C}$		230		mA
I_{PK}	Peak Current ⁽²⁾	$T_J = +25^{\circ}\text{C}$		2.2		A

Notes:

1. Load and line regulation are specified at constant junction temperature. Changes in V_O due to heating effects must be taken into account separately. Pulse testing with low duty is used.
2. These parameters, although guaranteed, are not 100% tested in production.

Electrical Characteristics (MC7812E)

Refer to test circuit, $-40^{\circ}\text{C} < T_J < 125^{\circ}\text{C}$, $I_O = 500\text{ mA}$, $V_I = 19\text{ V}$, $C_I = 0.33\text{ }\mu\text{F}$, $C_O = 0.1\text{ }\mu\text{F}$, unless otherwise specified.

Symbol	Parameter	Conditions	Min.	Typ.	Max.	Unit	
V_O	Output Voltage	$T_J = +25^{\circ}\text{C}$	11.5	12.0	12.5	V	
		$5.0\text{ mA} \leq I_O \leq 1.0\text{ A}$, $P_O \leq 15\text{ W}$, $V_I = 14.5\text{ V to } 27\text{ V}$	11.4	12.0	12.6		
Regline	Line Regulation ⁽³⁾	$T_J = +25^{\circ}\text{C}$	$V_I = 14.5\text{ V to } 30\text{ V}$		10	240	mV
			$V_I = 16\text{ V to } 22\text{ V}$		3	120	
Regload	Load Regulation ⁽³⁾	$T_J = +25^{\circ}\text{C}$	$I_O = 5\text{ mA to } 1.5\text{ A}$		11	240	mV
			$I_O = 250\text{ mA to } 750\text{ mA}$		5	120	
I_Q	Quiescent Current	$T_J = +25^{\circ}\text{C}$		5.1	8.0	mA	
ΔI_Q	Quiescent Current Change	$I_O = 5\text{ mA to } 1.0\text{ A}$		0.1	0.5	mA	
		$V_I = 14.5\text{ V to } 30\text{ V}$		0.5	1.0		
$\Delta V_O/\Delta T$	Output Voltage Drift ⁽⁴⁾	$I_O = 5\text{ mA}$		-1		mV/ $^{\circ}\text{C}$	
V_N	Output Noise Voltage	$f = 10\text{ Hz to } 100\text{ kHz}$, $T_A = +25^{\circ}\text{C}$		76		μV	
RR	Ripple Rejection ⁽⁴⁾	$f = 120\text{ Hz}$, $V_I = 15\text{ V to } 25\text{ V}$	55	71		dB	
V_{Drop}	Dropout Voltage	$I_O = 1\text{ A}$, $T_J = +25^{\circ}\text{C}$		2		V	
r_O	Output Resistance ⁽⁴⁾	$f = 1\text{ kHz}$		18		m Ω	
I_{SC}	Short Circuit Current	$V_I = 35\text{ V}$, $T_A = +25^{\circ}\text{C}$		230		mA	
I_{PK}	Peak Current ⁽⁴⁾	$T_J = +25^{\circ}\text{C}$		2.2		A	

Notes:

- Load and line regulation are specified at constant junction temperature. Changes in V_O due to heating effects must be taken into account separately. Pulse testing with low duty is used.
- These parameters, although guaranteed, are not 100% tested in production.

Typical Performance Characteristics

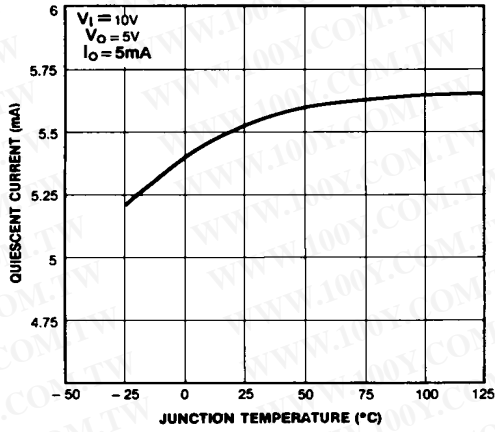

Figure 2. Quiescent Current

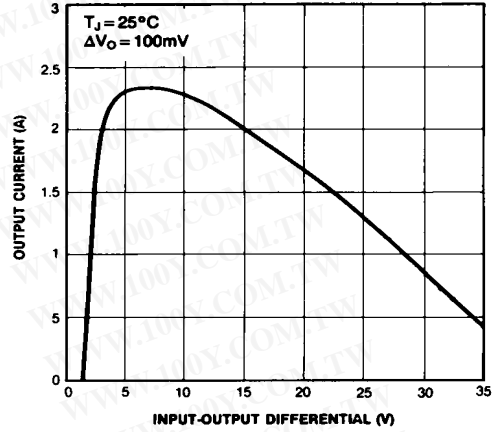

Figure 3. Peak Output Current

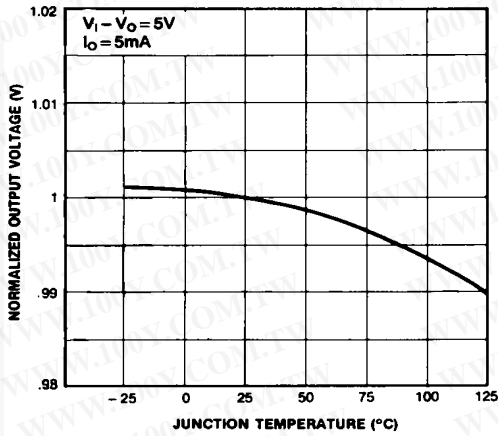

Figure 4. Output Voltage

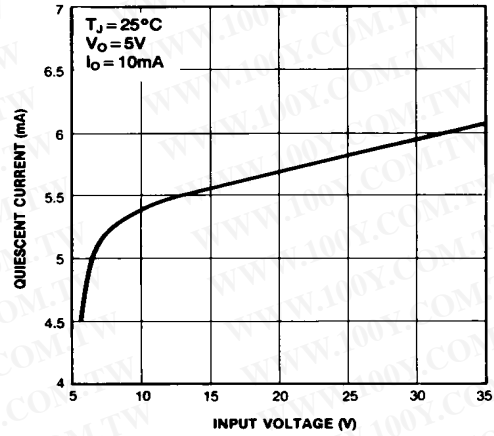

Figure 5. Quiescent Current

Typical Applications

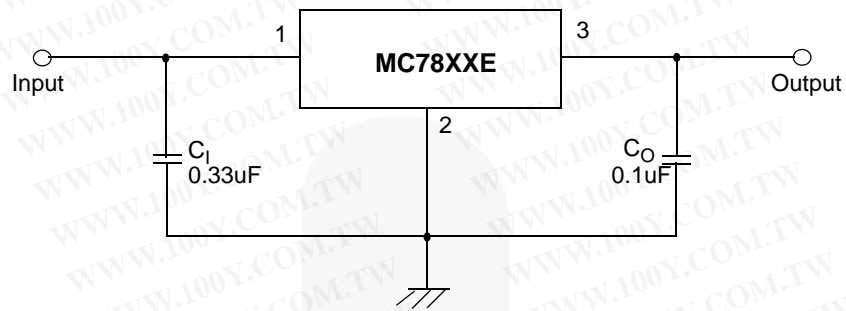

Figure 6. DC Parameters

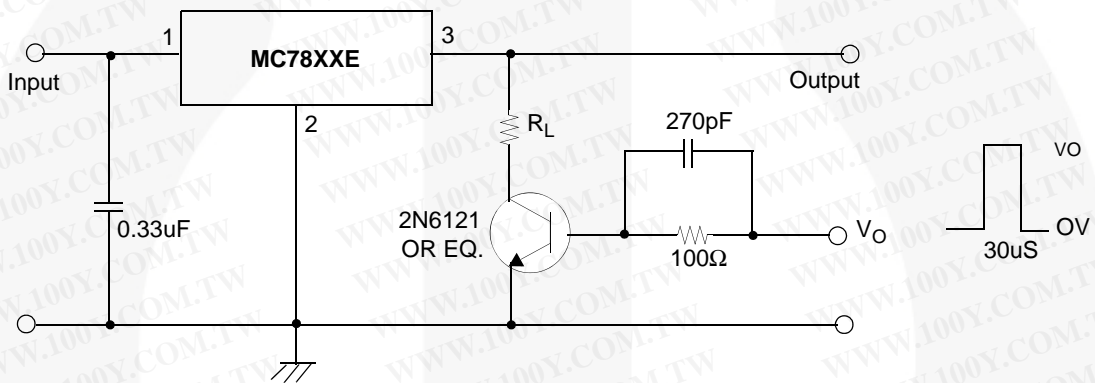

Figure 7. Load Regulation

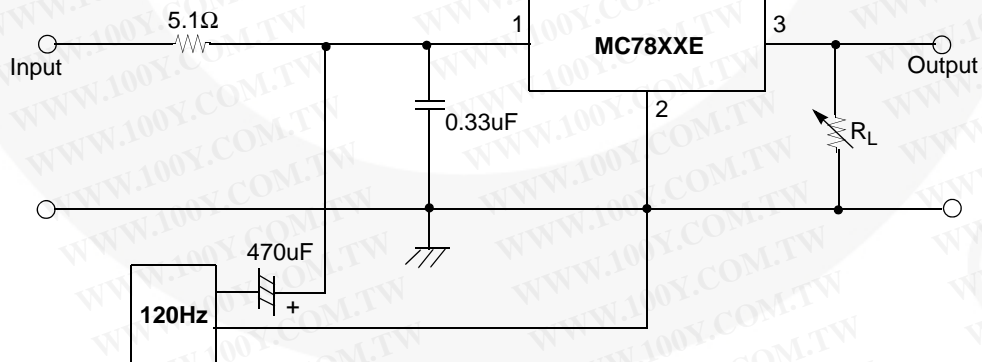

Figure 8. Ripple Rejection

Typical Applications (Continued)

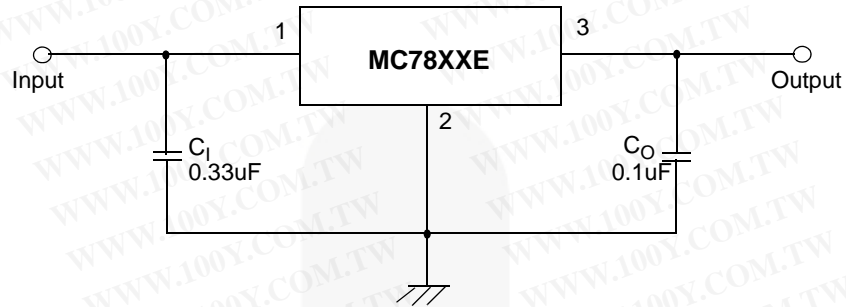

Figure 9. Fixed Output Regulator

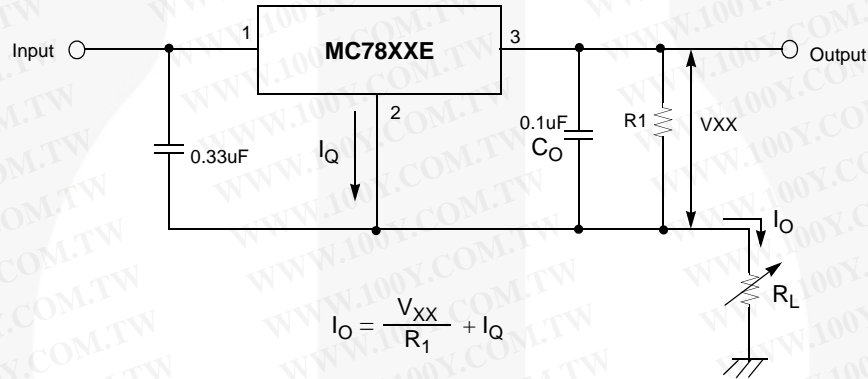

Figure 10. Constant Current Regulator

Notes:

5. To specify an output voltage, substitute voltage value for "XX." A common ground is required between the input and the Output voltage. The input voltage must remain typically 2.0V above the output voltage even during the low point on the input ripple voltage.
6. C₁ is required if regulator is located an appreciable distance from power Supply filter.
7. C_O improves stability and transient response.

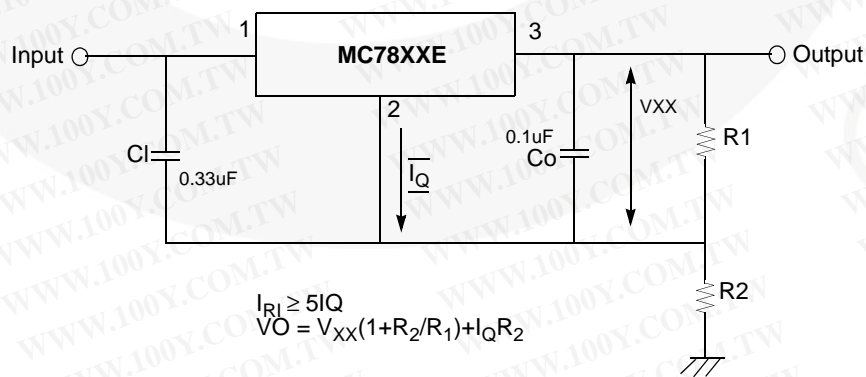

Figure 11. Circuit for Increasing Output Voltage

Typical Applications (Continued)

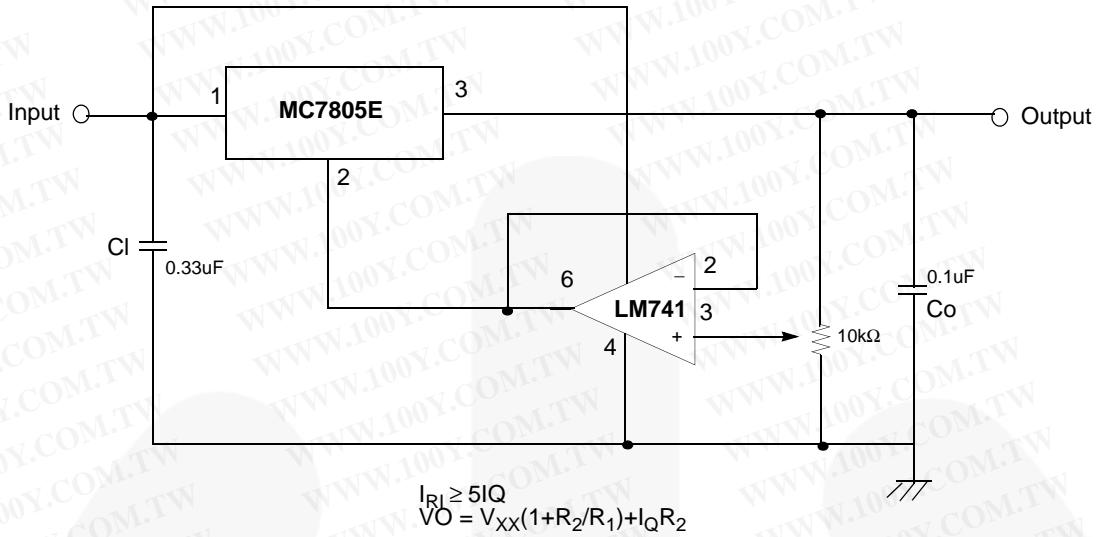

Figure 12. Adjustable Output Regulator (7 to 30V)

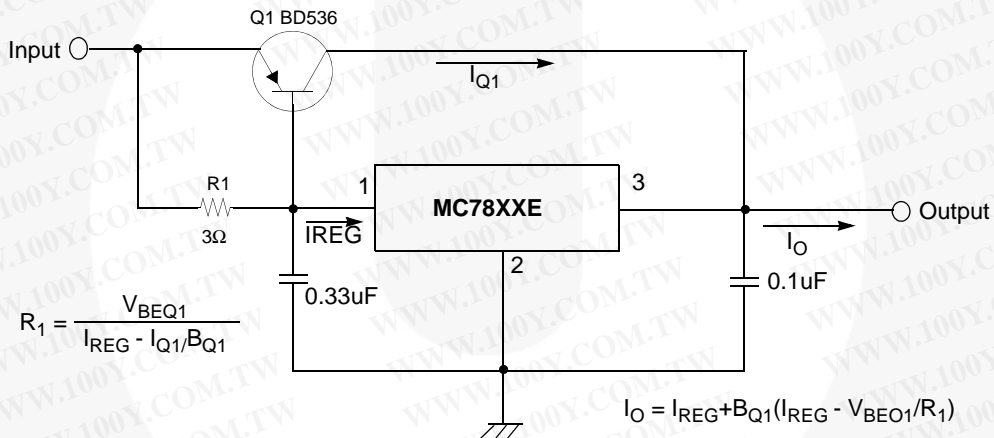

Figure 13. High Current Voltage Regulator

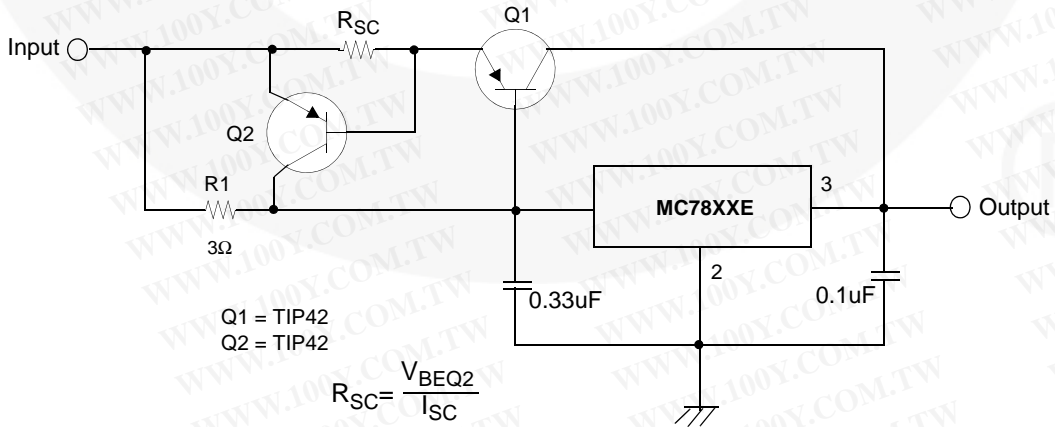

Figure 14. High Output Current with Short Circuit Protection

Typical Applications (Continued)

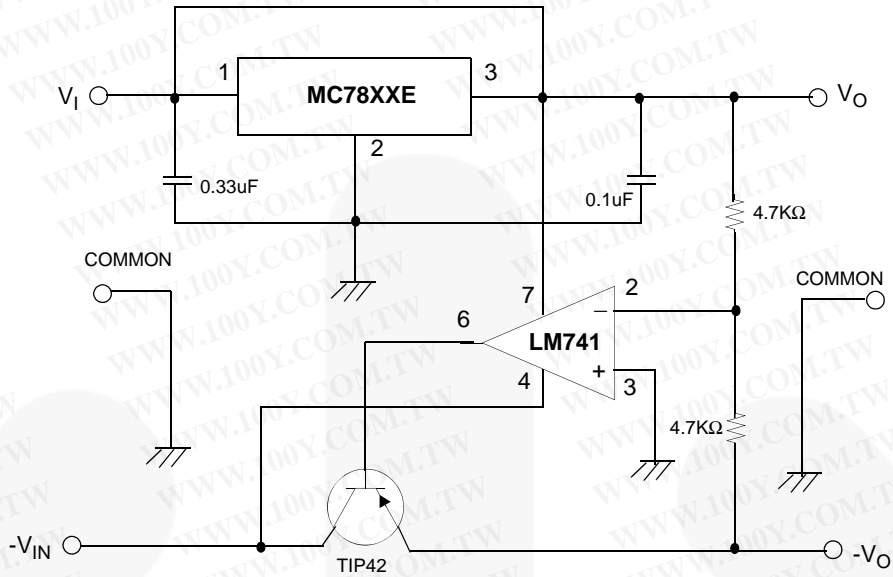

Figure 15. Tracking Voltage Regulator

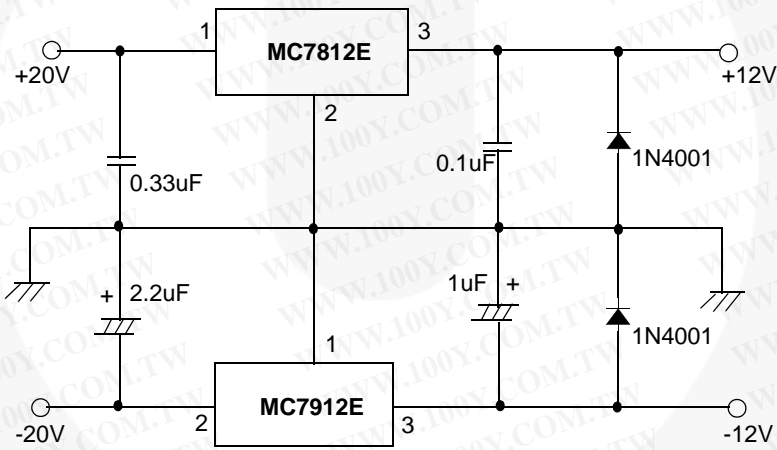

Figure 16. Split Power Supply ($\pm 12\text{ V} - 1\text{ A}$)

Typical Applications (Continued)

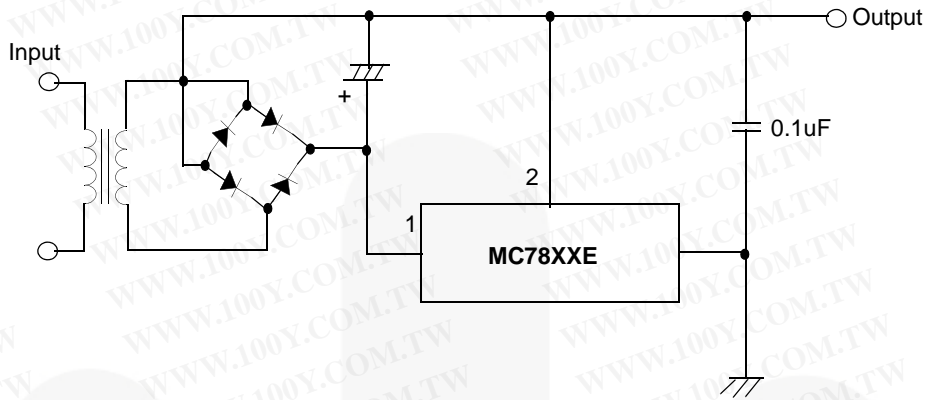

Figure 17. Negative Output Voltage Circuit

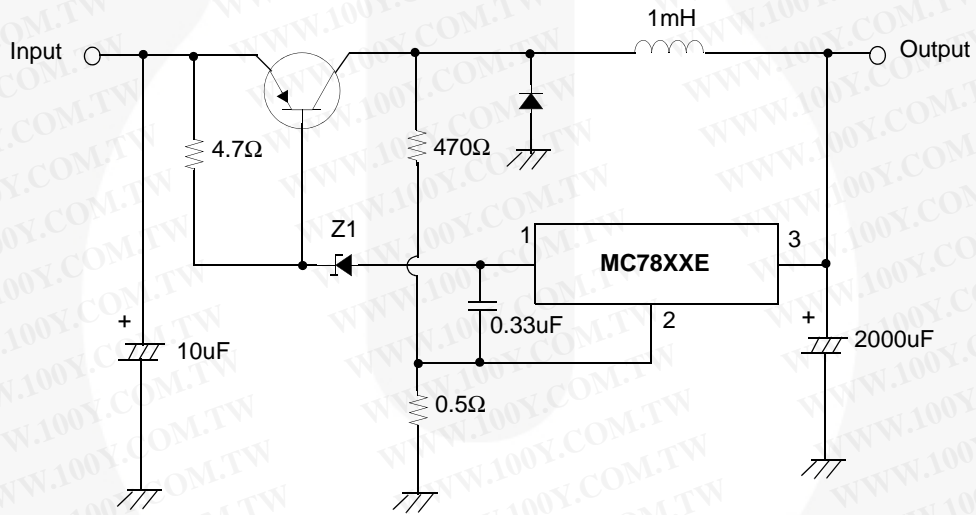

Figure 18. Switching Regulator

Physical Dimensions

勝特力材料 886-3-5753170
 勝特力电子(上海) 86-21-34970699
 勝特力电子(深圳) 86-755-83298787
 Http://www.100y.com.tw

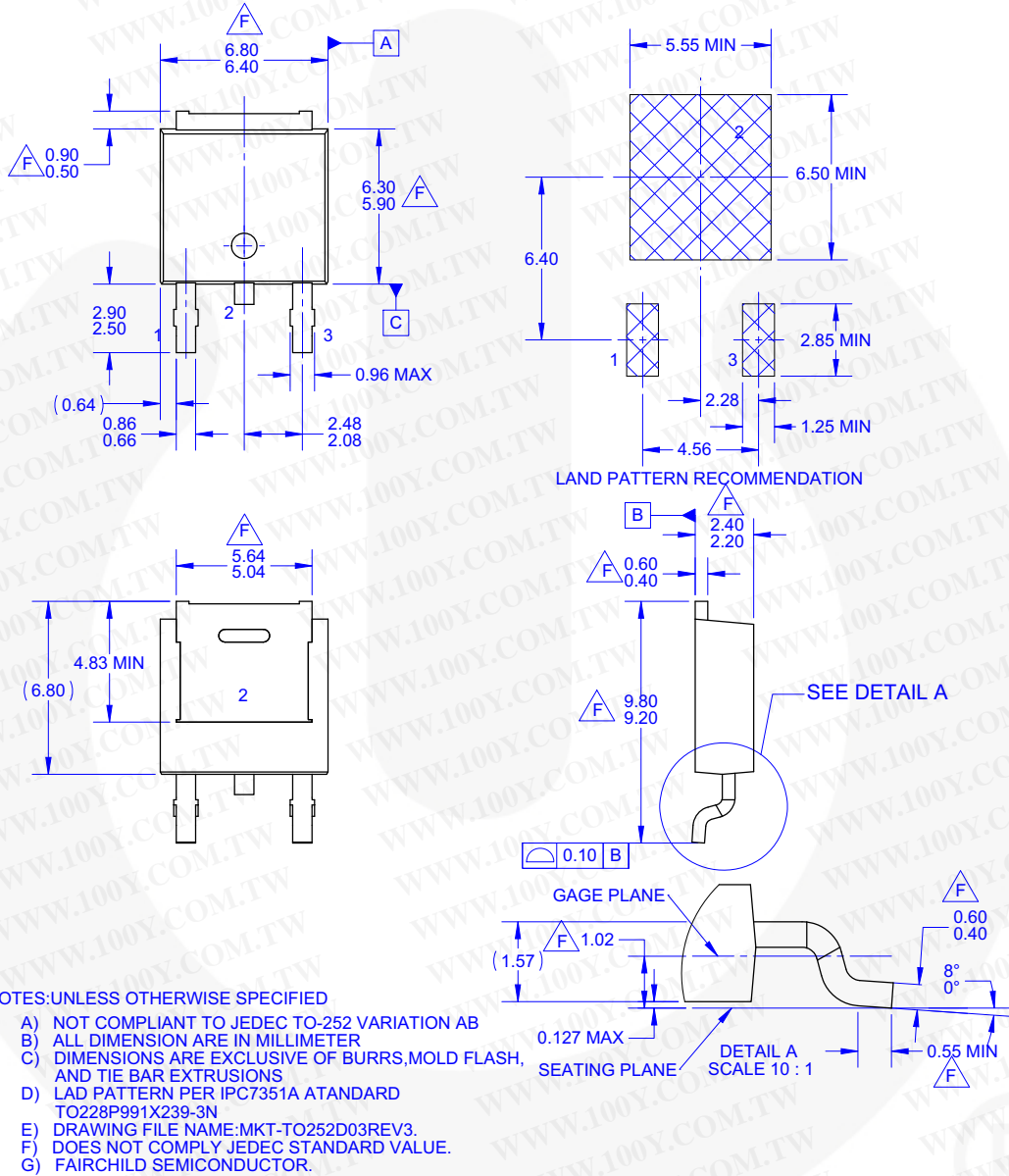

Figure 19. 3LEAD, TO-252, NOT COMPLIANT JEDEC TO-252 VAR. AB, SURFACE MOUNT (DPAK)