

## FEATURES

- Fixed 5V Output
- 2A On-Board Switch
- 100kHz Switching Frequency
- 2% Output Voltage Tolerance Over Temperature
- Greatly Improved Dynamic Behavior
- Available in Low Cost 5- and 7-Lead Packages
- Only 9.5mA Quiescent Current
- Operates Up to 60V Input

## APPLICATIONS

- 5V Output Buck Converter
- Tapped Inductor Buck Converter with 4A Output at 5V
- Positive-to-Negative Converter

勝特力材料 886-3-5753170  
 勝特力电子(上海) 86-21-54151736  
 勝特力电子(深圳) 86-755-83298787  
 Http://www.100y.com.tw

## DESCRIPTION

The LT<sup>®</sup>1076-5 is a 2A fixed 5V output monolithic bipolar switching regulator which requires only a few external parts for normal operation. The power switch, all oscillator and control circuitry, all current limit components, and an output monitor are included on the chip. The topology is a classic positive “buck” configuration but several design innovations allow this device to be used as a positive-to-negative converter, a negative boost converter, and as a flyback converter. The switch output is specified to swing 40V below ground, allowing the LT1076-5 to drive a tapped inductor in the buck mode with output currents up to 4A.

The LT1076-5 uses a true analog multiplier in the feedback loop. This makes the device respond nearly instantaneously to input voltage fluctuations and makes loop gain independent of input voltage. As a result, dynamic behavior of the regulator is significantly improved over previous designs.

On-chip pulse by pulse current limiting makes the LT1076-5 nearly bust-proof for output overloads or shorts. The input voltage range as a buck converter is 8V to 60V, but a self-boot feature allows input voltages as low as 5V in the inverting and boost configurations.

The LT1076-5 is available in a low cost 5- and 7-lead TO-220 packages with frequency pre-set at 100kHz and current limit at 2.6A. See Application Note 44 for design details.

LT, LT, LTC and LTM are registered trademarks of Linear Technology Corporation. All other trademarks are the property of their respective owners.

## TYPICAL APPLICATION

Basic Positive Buck Converter

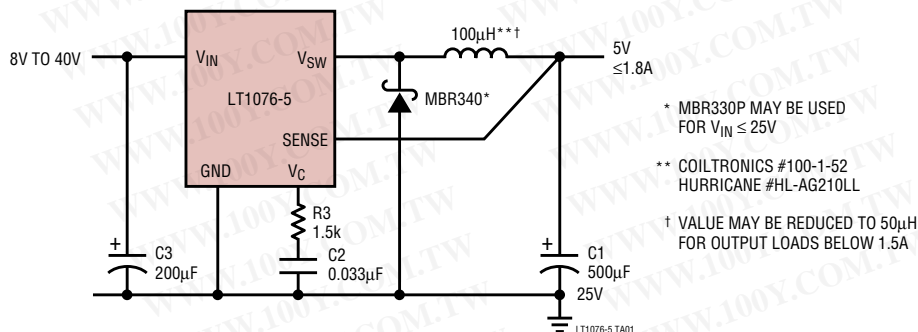

# LT1076-5

## ABSOLUTE MAXIMUM RATINGS

(Note 1)

Input Voltage		Sense Pin Voltage	..... -2V, 10V
LT1076-5	..... 45V	Maximum Operating Ambient Temperature Range	
LT1076HV-5	..... 64V	LT1076C-5, LT1076HVC-5	..... 0°C to 70°C
Switch Voltage with Respect to Input Voltage		LT1076I-5, LT1076HVI-5	..... -40°C to 85°C
LT1076-5	..... 64V	Maximum Operating Junction Temperature Range	
LT1076HV-5	..... 75V	LT1076C-5, LT1076HVC-5	..... 0°C to 125°C
Switch Voltage with Respect to Ground Pin		LT1076I-5, LT1076HVI-5	..... -40°C to 125°C
( $V_{SW}$ Negative)		Maximum Storage Temperature	..... -65°C to 150°C
LT1076-5 (Note 6)	..... 35V	Lead Temperature (Soldering, 10 sec)	..... 300°C
LT1076HV-5 (Note 6)	..... 45V		

## PACKAGE/ORDER INFORMATION

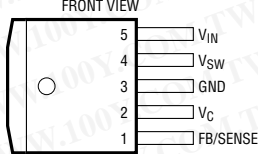
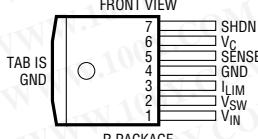
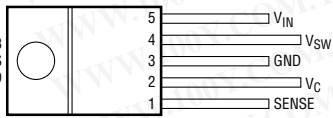
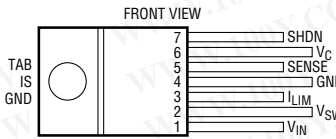
 <p>FRONT VIEW</p> <p>Q PACKAGE 5-LEAD PLASTIC DD <math>\theta_{JC} = 4^{\circ}\text{C/W}</math>, <math>\theta_{JA} = 30^{\circ}\text{C/W}</math></p>	 <p>FRONT VIEW</p> <p>R PACKAGE 7-LEAD PLASTIC DD <math>\theta_{JC} = 4^{\circ}\text{C/W}</math>, <math>\theta_{JA} = 30^{\circ}\text{C/W}</math></p>	<p>ORDER PART NUMBER</p> <p>LT1076CQ-5</p>	<p>ORDER PART NUMBER</p> <p>LT1076CR-5</p>
 <p>FRONT VIEW</p> <p>T PACKAGE 5-LEAD PLASTIC TO-220 LEADS ARE FORMED STANDARD FOR STRAIGHT LEADS, ORDER FLOW 06 <math>\theta_{JC} = 4^{\circ}\text{C/W}</math>, <math>\theta_{JA} = 50^{\circ}\text{C/W}</math></p>	 <p>FRONT VIEW</p> <p>T7 PACKAGE 7-LEAD PLASTIC TO-220 <math>\theta_{JC} = 4^{\circ}\text{C/W}</math>, <math>\theta_{JA} = 50^{\circ}\text{C/W}</math></p>	<p>ORDER PART NUMBER</p> <p><b>LT1076CT-5</b> LT1076HVCT-5 LT1076IT-5 LT1076HVIT-5</p>	<p>ORDER PART NUMBER</p> <p>LT1076CT7-5</p>
<p>Order Options Tape and Reel: Add #TR Lead Free: Add #PBF Lead Free Tape and Reel: Add #TRPBF Lead Free Part Marking: <a href="http://www.linear.com/leadfree/">http://www.linear.com/leadfree/</a></p>			

Consult LTC Marketing for parts specified with wider operating temperature ranges. \*The temperature grade is identified by a label on the shipping container.

## ELECTRICAL CHARACTERISTICS

The ● denotes the specifications which apply over the full operating temperature range, otherwise specifications are at  $T_J = 25^{\circ}\text{C}$ .  $V_{IN} = 25\text{V}$ , unless otherwise noted.

SYMBOL	CONDITIONS	MIN	TYP	MAX	UNITS
Switch "On" Voltage (Note 2)	$I_{SW} = 0.5\text{A}$	●		1.2	V
	$I_{SW} = 2\text{A}$	●		1.7	V
Switch "Off" Leakage	$V_{IN} = 25\text{V}$ , $V_{SW} = 0$			150	$\mu\text{A}$
	$V_{IN} = 25\text{V}$ , $V_{SW} = 0$			250	$\mu\text{A}$

勝特力材料 886-3-5753170  
 勝特力电子(上海) 86-21-54151736  
 勝特力电子(深圳) 86-755-83298787  
[Http://www.100y.com.tw](http://www.100y.com.tw)

10765fc

**ELECTRICAL CHARACTERISTICS** The ● denotes the specifications which apply over the full operating temperature range, otherwise specifications are at  $T_J = 25^\circ\text{C}$ .  $V_{IN} = 25\text{V}$ , unless otherwise noted.

SYMBOL	CONDITIONS	MIN	TYP	MAX	UNITS	
Supply Current (Note 3)	$V_{OUT} = 5.5\text{V}$ , $V_{IN} \leq 40\text{V}$ $40\text{V} < V_{IN} < 60\text{V}$ $V_{SHDN} = 0.1\text{V}$ (Device Shutdown) (Note 9)	●	8.5	11	mA	
		●	9.0	12	mA	
		●	140	300	$\mu\text{A}$	
Minimum Supply Voltage	Normal Mode	●	7.3	8.0	V	
		●	3.5	4.8	V	
Switch Current Limit (Note 5)	$I_{LIM} = \text{Open}$ $R_{LIM} = 10\text{k}$ (Note 10) $R_{LIM} = 7\text{k}$ (Note 10)	●	2	2.6	3.2	A
		●		1.8		A
		●		1.2		A
Maximum Duty Cycle		●	85	90	%	
Switching Frequency	$T_J \leq 125^\circ\text{C}$ $V_{OUT} = V_{SENSE} = 0\text{V}$ (Note 5)	●	90	100	110	kHz
		●	85		120	kHz
		●		20		kHz
Switching Frequency Line Regulation	$8\text{V} \leq V_{IN} \leq V_{MAX}$ (Note 8)	●		0.03	0.1	%/V
Error Amplifier Voltage Gain (Note 8)	$1\text{V} \leq V_C \leq 4\text{V}$			2000		V/V
Error Amplifier Transconductance (Note 8)			3700	5000	8000	$\mu\text{mho}$
Error Amplifier Source and Sink Current	Source ( $V_{SENSE} = 4.5\text{V}$ ) Sink ( $V_{SENSE} = 5.5\text{V}$ )		100	140	225	$\mu\text{A}$
			0.7	1.0	1.6	mA
Sense Pin Divider Resistance			3	5	8	k $\Omega$
Sense Voltage	$V_C = 2\text{V}$	●	4.85	5	5.15	V
Output Voltage Tolerance	$V_{OUT}$ (Nominal) = 5V All Conditions of Input Voltage, Output Voltage, Temperature and Load Current	●		$\pm 0.5$	$\pm 2$	%
		●		$\pm 1.0$	$\pm 3$	%
Output Voltage Line Regulation	$8\text{V} \leq V_{IN} \leq V_{MAX}$ (Note 7)	●		0.005	0.02	%/V
VC Voltage at 0% Duty Cycle	Over Temperature	●		1.5		V
		●		-4.0		mV/ $^\circ\text{C}$
Multiplier Reference Voltage				24		V
Shutdown Pin Current	$V_{SHDN} = 5\text{V}$ $V_{SHDN} \leq V_{THRESHOLD} (\approx 2.5\text{V})$		5	10	20	$\mu\text{A}$
					50	$\mu\text{A}$
Shutdown Thresholds	Switch Duty Cycle = 0 Fully Shut Down		2.2	2.45	2.7	V
			0.1	0.30	0.5	V
Thermal Resistance Junction to Case					4	$^\circ\text{C}/\text{W}$

**Note 1:** Stresses beyond those listed under Absolute Maximum Ratings may cause permanent damage to the device. Exposure to any Absolute Maximum Rating condition for extended periods may affect device reliability and lifetime.

**Note 2:** To calculate maximum switch “on” voltage at currents between low and high conditions, a linear interpolation may be used.

**Note 3:** A sense pin voltage ( $V_{SENSE}$ ) of 5.5V forces the VC pin to its low clamp level and the switch duty cycle to zero. This approximates the zero load condition where duty cycle approaches zero.

**Note 4:** Total voltage from  $V_{IN}$  pin to ground pin must be  $\geq 8\text{V}$  after start-up for proper regulation. For  $T_A < 25^\circ\text{C}$ , limit = 5V.

**Note 5:** Switch frequency is internally scaled down when the sense pin voltage is less than 2.6V to avoid extremely short switch on times. During

current limit testing,  $V_{SENSE}$  is adjusted to give a minimum switch on time of 1ms.

**Note 6:** Switch to input voltage limitation must also be observed.

**Note 7:**  $V_{MAX} = 40\text{V}$  for the LT1076-5 and 60V for the LT1076HV-5.

**Note 8:** Error amplifier voltage gain and transconductance are specified relative to the internal feedback node. To calculate gain and transconductance from the Sense pin (Output) to the  $V_C$  pin, multiply by 0.44.

**Note 9:** Does not include switch leakage.

**Note 10:**  $I_{LIM} \approx \frac{R_{LIM} - 1\text{k}}{5\text{k}}$

勝特力材料 886-3-5753170  
 勝特力电子(上海) 86-21-54151736  
 勝特力电子(深圳) 86-755-83298787  
[Http://www.100y.com.tw](http://www.100y.com.tw)

**PACKAGE DESCRIPTION**

**Q Package  
5-Lead Plastic DD Pak**

(Reference LTC DWG # 05-08-1461)

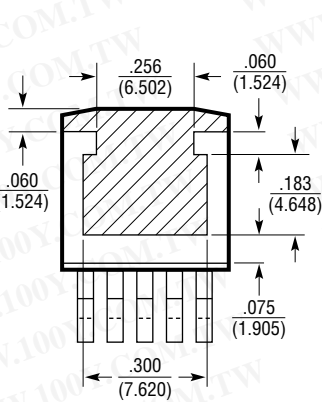

**BOTTOM VIEW OF DD PAK**  
HATCHED AREA IS SOLDER PLATED  
COPPER HEAT SINK

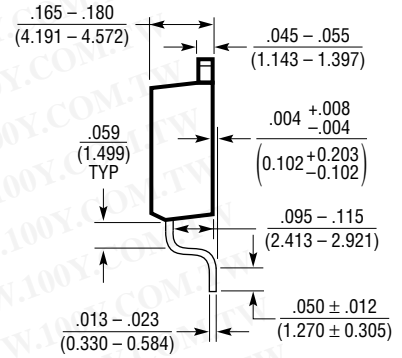
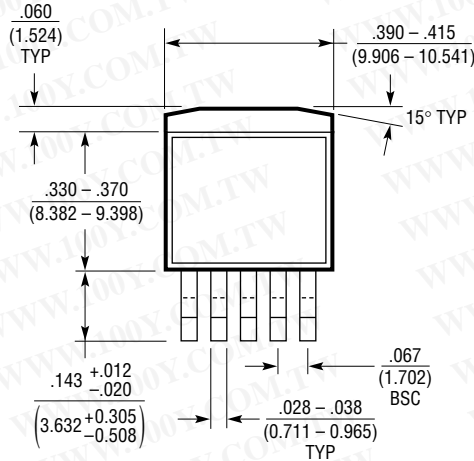

Q(DD5) 0502

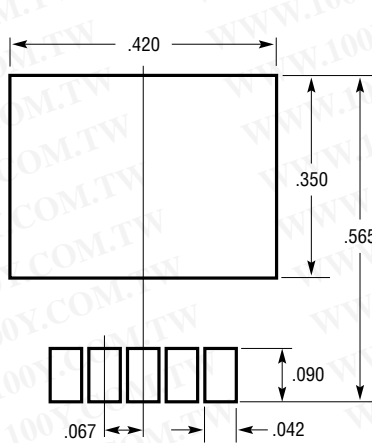

**RECOMMENDED SOLDER PAD LAYOUT**

- NOTE:**  
1. DIMENSIONS IN INCH/(MILLIMETER)  
2. DRAWING NOT TO SCALE

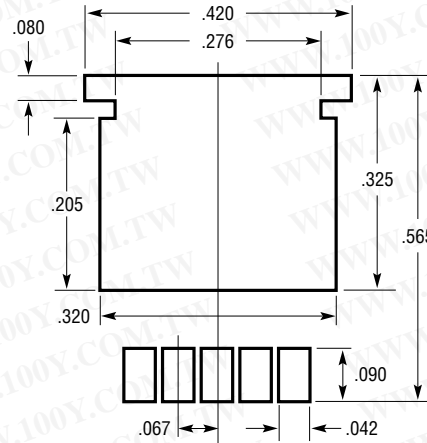

**RECOMMENDED SOLDER PAD LAYOUT  
FOR THICKER SOLDER PASTE APPLICATIONS**

勝特力材料 886-3-5753170  
 勝特力电子(上海) 86-21-54151736  
 勝特力电子(深圳) 86-755-83298787  
[Http://www.100y.com.tw](http://www.100y.com.tw)

**R Package**  
**7-Lead Plastic DD Pak**  
 (Reference LTC DWG # 05-08-1462)

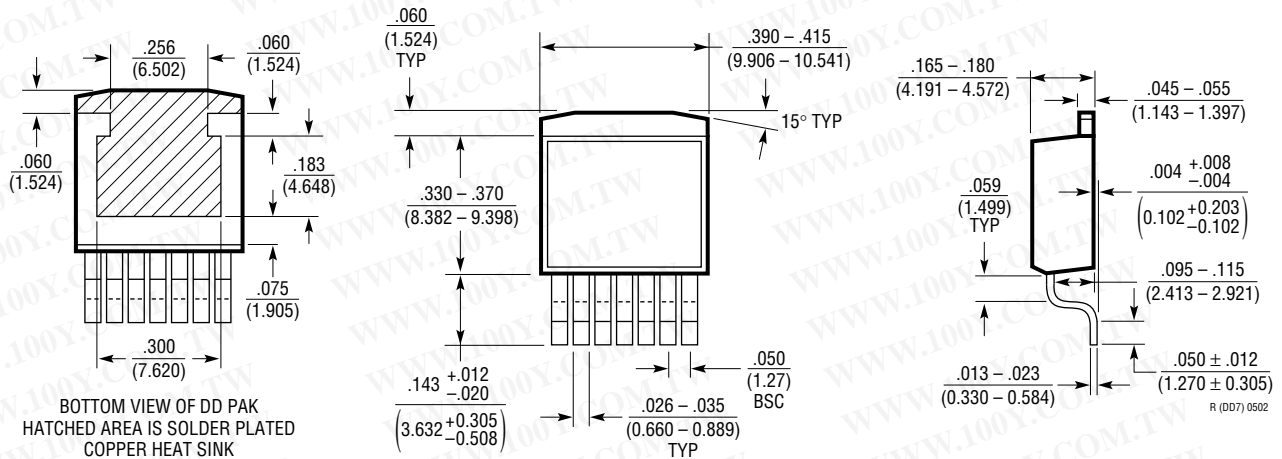

BOTTOM VIEW OF DD PAK  
 HATCHED AREA IS SOLDER PLATED  
 COPPER HEAT SINK

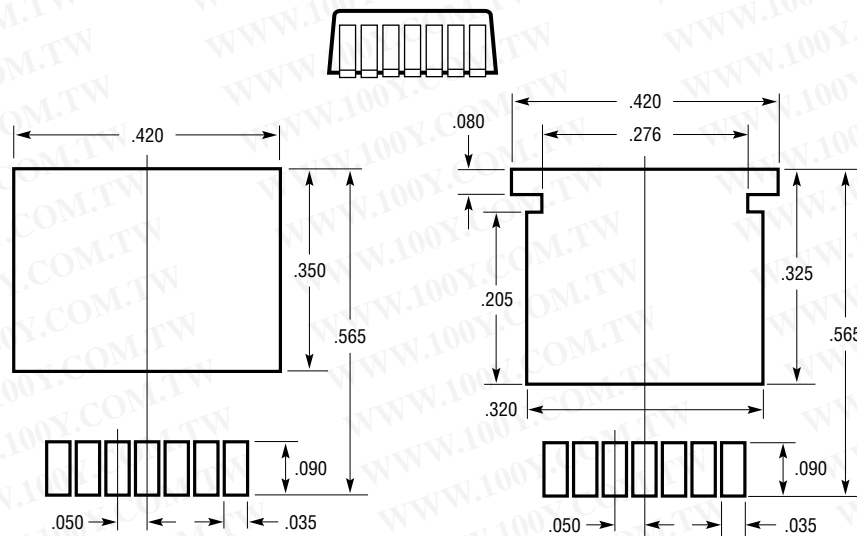

RECOMMENDED SOLDER PAD LAYOUT  
 NOTE:  
 1. DIMENSIONS IN INCH/(MILLIMETER)  
 2. DRAWING NOT TO SCALE

RECOMMENDED SOLDER PAD LAYOUT  
 FOR THICKER SOLDER PASTE APPLICATIONS

勝特力材料 86-3-5753170  
 勝特力电子(上海) 86-21-54151736  
 勝特力电子(深圳) 86-755-83298787  
[Http://www.100y.com.tw](http://www.100y.com.tw)

**PACKAGE DESCRIPTION**

**T Package**  
**5-Lead Plastic TO-220 (Standard)**  
 (Reference LTC DWG # 05-08-1421)

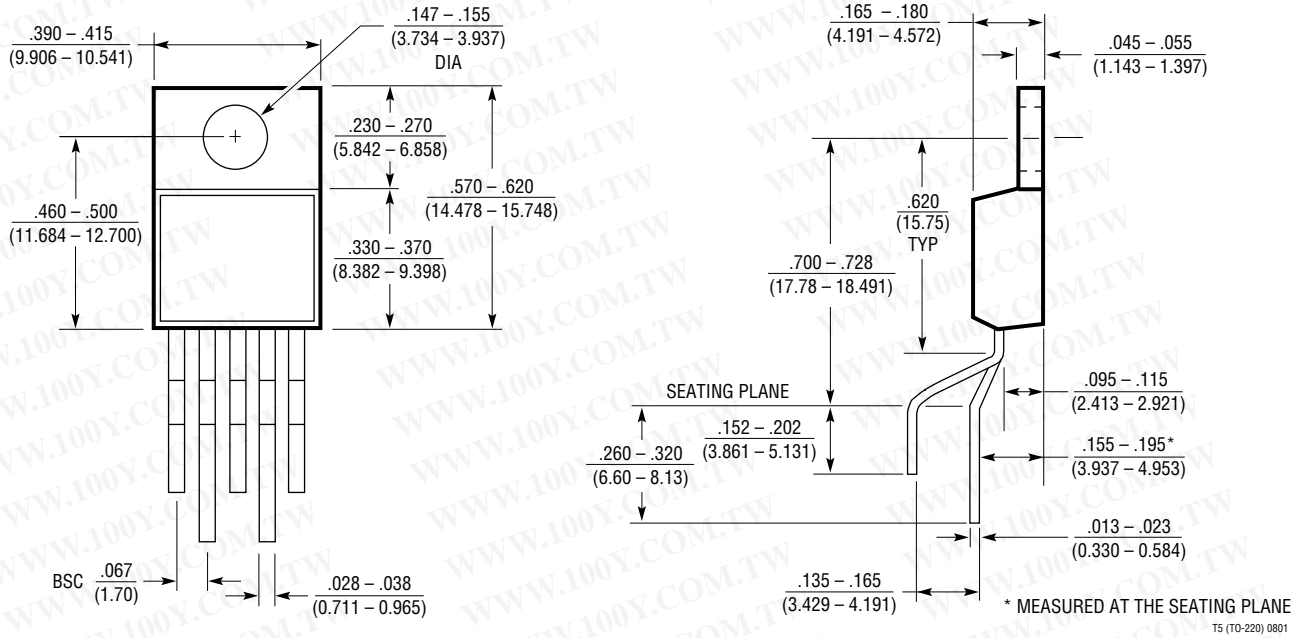

勝特力材料 886-3-5753170  
 勝特力电子(上海) 86-21-54151736  
 勝特力电子(深圳) 86-755-83298787  
[Http://www.100y.com.tw](http://www.100y.com.tw)

PACKAGE DESCRIPTION

**T7 Package**  
**7-Lead Plastic TO-220 (Standard)**  
 (Reference LTC DWG # 05-08-1422)

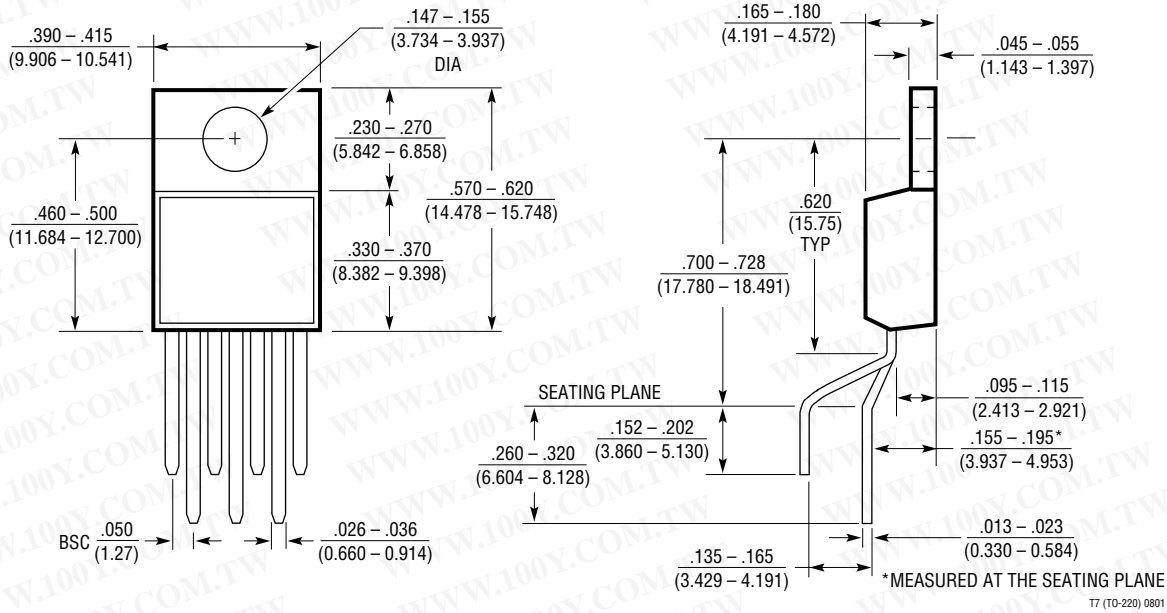

勝特力材料 886-3-5753170  
 勝特力电子(上海) 86-21-54151736  
 勝特力电子(深圳) 86-755-83298787  
[Http://www.100y.com.tw](http://www.100y.com.tw)

# LT1076-5

## RELATED PARTS

PART NUMBER	DESCRIPTION	COMMENTS
LT1074/HV	4.4A (I <sub>OUT</sub> ), 100kHz High Efficiency Step-Down DC/DC Converter	V <sub>IN</sub> : 7.3V to 45V/64V, V <sub>OUT(MIN)</sub> : 2.21V, I <sub>Q</sub> : 8.5mA, I <sub>SHDN</sub> : 10μA, DD5/7, TO-2205/7
LT3430	60V, 2.75A (I <sub>OUT</sub> ), 200kHz High Efficiency Step-Down DC/DC Converter	V <sub>IN</sub> : 5.5V to 60V, V <sub>OUT(MIN)</sub> : 1.20V, I <sub>Q</sub> : 2.5mA, I <sub>SHDN</sub> : 25μA, TSSOP16E
LT1956	60V, 1.2A (I <sub>OUT</sub> ), 500kHz High Efficiency Step-Down DC/DC Converter	V <sub>IN</sub> : 5.5V to 60V, V <sub>OUT(MIN)</sub> : 1.20V, I <sub>Q</sub> : 2.5mA, I <sub>SHDN</sub> : 25μA, TSSOP16E

勝特力材料 886-3-5753170  
勝特力电子(上海) 86-21-54151736  
勝特力电子(深圳) 86-755-83298787  
[Http://www.100y.com.tw](http://www.100y.com.tw)