



MIC5370/1

High-Performance Dual 150mA LDO
1.6mm x 1.6mm Thin MLF[®]

General Description

The MIC5370/1 is an advanced dual LDO ideal for powering general purpose portable devices. The MIC5370/1 provides two independently-controlled, high-performance 150mA LDOs in a tiny 1.6mm x 1.6mm Thin MLF[®] package.

Ideal for battery-powered applications, the MIC5370/1 offers 2% initial accuracy, low dropout voltage (155mV @ 150mA) and low ground current (typically 32 μ A per LDO). The MIC5370/1 can also be put into a zero-off-mode current state, drawing virtually no current when disabled.

When the MIC5371 is disabled an internal resistive load is automatically applied to the output to discharge the output capacitor. This LDO offers fast transient response and high PSRR while consuming a minimum operating current.

The MIC5370/1 is available in fixed output voltages in a lead-free (RoHS-compliant) 6-pin 1.6mm x 1.6mm Thin MLF[®] package.

Data sheets and support documentation can be found on Micrel's web site at: www.micrel.com.

Features

- 2.5V to 5.5V input voltage range
- Two 150mA output current LDOs
- High output accuracy
 - $\pm 2\%$ initial accuracy
- Low quiescent current – 32 μ A per LDO
- Stable with 1 μ F ceramic output capacitors
- Independent enable pins
- Low dropout voltage – 155mV at 150mA
- Thermal-shutdown protection
- Current-limit protection
- Output discharge circuit – MIC5371
- 6-pin 1.6mm x 1.6mm Thin MLF[®] package

Applications

- Camera phones
- Mobile phones
- GPS, PMP, PDAs and handhelds
- Portable electronics

Typical Application

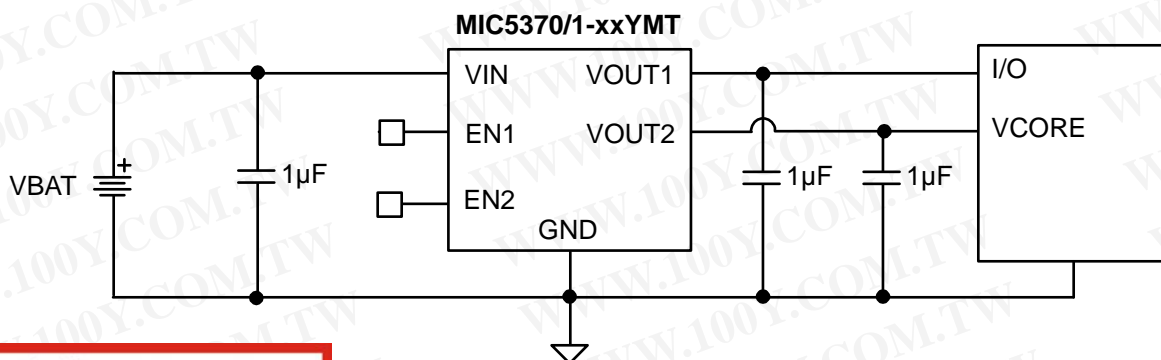

Camera DSP Power Supply Circuit

勝特力材料 886-3-5753170
勝特力电子(上海) 86-21-34970699
勝特力电子(深圳) 86-755-83298787
[Http://www.100y.com.tw](http://www.100y.com.tw)

MLF and MicroLeadFrame are registered trademarks of Amkor Technology, Inc.

Micrel Inc. • 2180 Fortune Drive • San Jose, CA 95131 • USA • tel +1 (408) 944-0800 • fax + 1 (408) 474-1000 • <http://www.micrel.com>

Block Diagrams

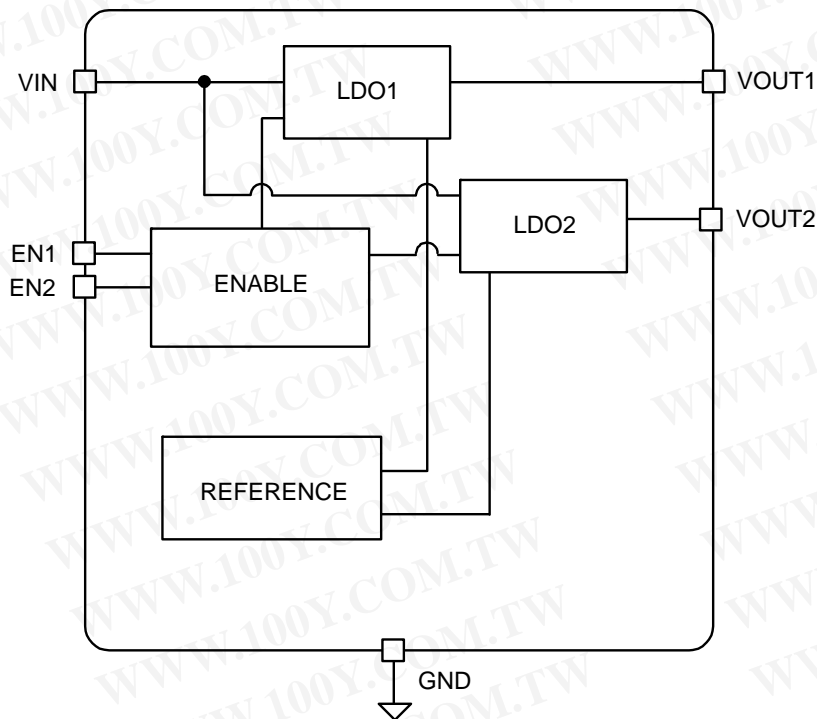

MIC5370 Block Diagram

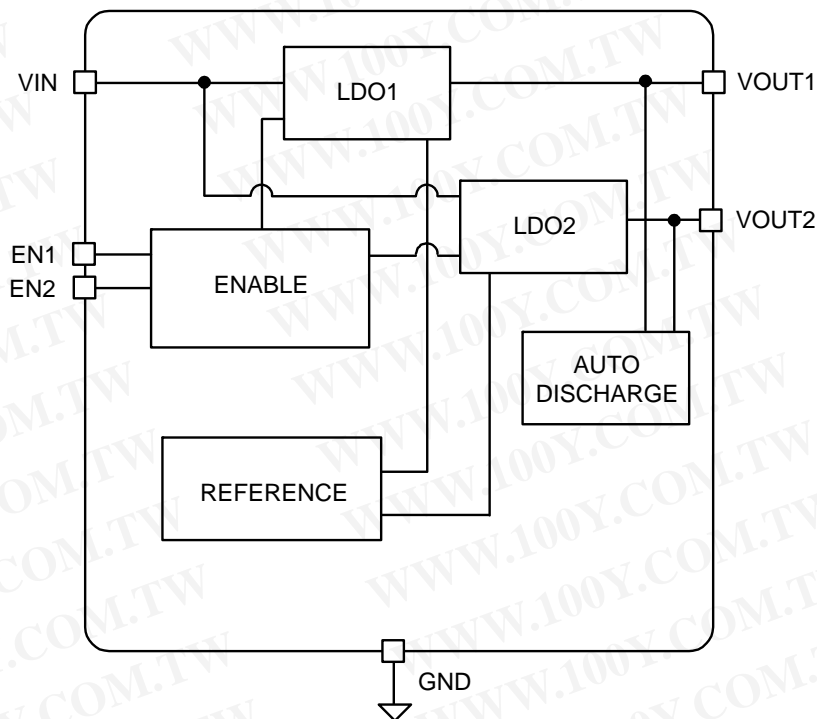

MIC5371 Block Diagram

Ordering Information

Part Number	Manufacturing Part Number	Marking Code	Voltage	Junction Temperature Range	Package	Lead Finish
MIC5370-3.3/3.3YMT	MIC5370-SSYMT	8SS	3.3V/3.3V	-40°C to +125°C	6-Pin 1.6mm × 1.6mm Thin MLF [®]	Pb-Free
MIC5370-3.3/3.0YMT	MIC5370-SPYMT	SP8	3.3V/3.0V	-40°C to +125°C	6-Pin 1.6mm × 1.6mm Thin MLF [®]	Pb-Free
MIC5370-3.3/2.8YMT	MIC5370-SMYMT	SM8	3.3V/2.8V	-40°C to +125°C	6-Pin 1.6mm × 1.6mm Thin MLF [®]	Pb-Free
MIC5370-3.3/2.6YMT	MIC5370-SKYMT	S8K	3.3V/2.6V	-40°C to +125°C	6-Pin 1.6mm × 1.6mm Thin MLF [®]	Pb-Free
MIC5370-3.3/1.8YMT	MIC5370-SGYMT	SG8	3.3V/1.8V	-40°C to +125°C	6-Pin 1.6mm × 1.6mm Thin MLF [®]	Pb-Free
MIC5370-3.0/3.0YMT	MIC5370-PPYMT	P8P	3.0V/3.0V	-40°C to +125°C	6-Pin 1.6mm × 1.6mm Thin MLF [®]	Pb-Free
MIC5370-3.0/2.8YMT	MIC5370-PMYMT	PM8	3.0V/2.8V	-40°C to +125°C	6-Pin 1.6mm × 1.6mm Thin MLF [®]	Pb-Free
MIC5370-3.0/2.6YMT	MIC5370-PKYMT	P8K	3.0V/2.6V	-40°C to +125°C	6-Pin 1.6mm × 1.6mm Thin MLF [®]	Pb-Free
MIC5370-3.0/1.8YMT	MIC5370-PGYMT	PG8	3.0V/1.8V	-40°C to +125°C	6-Pin 1.6mm × 1.6mm Thin MLF [®]	Pb-Free
MIC5370-2.8/2.8YMT	MIC5370-MMYMT	MM8	2.8V/2.8V	-40°C to +125°C	6-Pin 1.6mm × 1.6mm Thin MLF [®]	Pb-Free
MIC5370-2.8/2.6YMT	MIC5370-MKYMT	M8K	2.8V/2.6V	-40°C to +125°C	6-Pin 1.6mm × 1.6mm Thin MLF [®]	Pb-Free
MIC5370-2.8/1.8YMT	MIC5370-MGYMT	MG8	2.8V/1.8V	-40°C to +125°C	6-Pin 1.6mm × 1.6mm Thin MLF [®]	Pb-Free
MIC5370-2.8/1.5YMT	MIC5370-MFYMT	MF8	2.8V/1.5V	-40°C to +125°C	6-Pin 1.6mm × 1.6mm Thin MLF [®]	Pb-Free
MIC5370-2.8/1.2YMT	MIC5370-M4YMT	J48	2.8V/1.2V	-40°C to +125°C	6-Pin 1.6mm × 1.6mm Thin MLF [®]	Pb-Free
MIC5370-1.8/1.2YMT	MIC5370-G4YMT	8G4	1.8V/1.2V	-40°C to +125°C	6-Pin 1.6mm × 1.6mm Thin MLF [®]	Pb-Free
MIC5370-1.2/1.0YMT	MIC5370-4CYMT	84C	1.2V/1.0V	-40°C to +125°C	6-Pin 1.6mm × 1.6mm Thin MLF [®]	Pb-Free
MIC5371-3.3/3.3YMT*	MIC5371-SSYMT	9SS	3.3V/3.3V	-40°C to +125°C	6-Pin 1.6mm × 1.6mm Thin MLF [®]	Pb-Free
MIC5371-3.3/3.0YMT*	MIC5371-SPYMT	9SP	3.3V/3.0V	-40°C to +125°C	6-Pin 1.6mm × 1.6mm Thin MLF [®]	Pb-Free
MIC5371-3.3/2.8YMT*	MIC5371-SMYMT	9SM	3.3V/2.8V	-40°C to +125°C	6-Pin 1.6mm × 1.6mm Thin MLF [®]	Pb-Free
MIC5371-3.3/1.8YMT*	MIC5371-SGYMT	9SG	3.3V/1.8V	-40°C to +125°C	6-Pin 1.6mm × 1.6mm Thin MLF [®]	Pb-Free
MIC5371-3.0/3.0YMT*	MIC5371-PPYMT	9PP	3.0V/3.0V	-40°C to +125°C	6-Pin 1.6mm × 1.6mm Thin MLF [®]	Pb-Free

Ordering Information (Continued)

Part Number	Manufacturing Part Number	Marking Code	Voltage	Junction Temperature Range	Package	Lead Finish
MIC5371-3.0/2.8YMT*	MIC5371-PMYMT	9PM	3.0V/2.8V	-40°C to +125°C	6-Pin 1.6mm × 1.6mm Thin MLF [®]	Pb-Free
MIC5371-2.8/2.8YMT*	MIC5371-MMYMT	9MM	2.8V/2.8V	-40°C to +125°C	6-Pin 1.6mm × 1.6mm Thin MLF [®]	Pb-Free
MIC5371-2.8/1.8YMT*	MIC5371-MGYMT	9MG	2.8V/1.8V	-40°C to +125°C	6-Pin 1.6mm × 1.6mm Thin MLF [®]	Pb-Free
MIC5371-2.8/1.5YMT*	MIC5371-MFYMT	9MF	2.8V/1.5V	-40°C to +125°C	6-Pin 1.6mm × 1.6mm Thin MLF [®]	Pb-Free
MIC5371-2.8/1.2YMT*	MIC5371-M4YMT	9M4	2.8V/1.2V	-40°C to +125°C	6-Pin 1.6mm × 1.6mm Thin MLF [®]	Pb-Free
MIC5371-1.8/1.2YMT*	MIC5371-G4YMT	9G4	1.8V/1.2V	-40°C to +125°C	6-Pin 1.6mm × 1.6mm Thin MLF [®]	Pb-Free
MIC5371-1.2/1.0YMT*	MIC5371-4CYMT	94C	1.2V/1.0V	-40°C to +125°C	6-Pin 1.6mm × 1.6mm Thin MLF [®]	Pb-Free

Note:

- Other voltages available. Contact Micrel for details.
 - Thin MLF[®] Pin 1 Identifier = ▲
 - Thin MLF[®] is a GREEN RoHS-compliant package. Level finish is NiPdAu. Mold compound is Halogen Free.
- * MIC5371 offers Auto-Discharge function.

勝特力材料 886-3-5753170
 勝特力电子(上海) 86-21-34970699
 勝特力电子(深圳) 86-755-83298787
[Http://www.100y.com.tw](http://www.100y.com.tw)

Pin Configuration

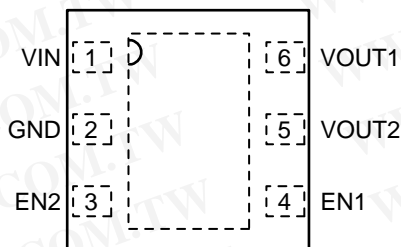

6-Pin 1.6mm x 1.6mm Thin MLF[®] (MT)

Pin Description

Pin Number	Pin Name	Pin Function
1	VIN	Supply Input
2	GND	Ground
3	EN2	Enable Input (regulator 2). Active High Input. Logic High = On; Logic Low = Off; Do not leave floating.
4	EN1	Enable Input (regulator 1). Active High Input. Logic High = On; Logic Low = Off; Do not leave floating.
5	VOUT2	Regulator Output – LDO2
6	VOUT1	Regulator Output – LDO1
EPAD	HS Pad	Heatsink Pad internally connected to ground.

Absolute Maximum Ratings⁽¹⁾

Supply Voltage (V_{IN})	-0.3V to +6V
Enable Voltage (V_{EN1} , V_{EN2})	-0.3V to V_{IN}
Power Dissipation (P_D)	Internally Limited ⁽³⁾
Lead Temperature (soldering, 10sec.)	260°C
Junction Temperature (T_J)	-40°C to +125°C
Storage Temperature (T_S)	-65°C to +150°C
ESD Rating ⁽⁴⁾	2kV

Operating Ratings⁽²⁾

Supply Voltage (V_{IN})	+2.5V to 5.5V
Enable Voltage (V_{EN1} , V_{EN2})	-0.3V to V_{IN}
Junction Temperature (T_J)	-40°C to +125°C
Junction Thermal Resistance 1.6x1.6 Thin MLF [®] -6 (θ_{JA})	90°C/W

勝特力材料 886-3-5753170
 勝特力电子(上海) 86-21-34970699
 勝特力电子(深圳) 86-755-83298787
[Http://www.100y.com.tw](http://www.100y.com.tw)

Electrical Characteristics⁽⁵⁾

$V_{IN} = V_{EN1} = V_{EN2} = V_{OUT} + 1V$; higher of the two regulator outputs; $I_{OUTLDO1} = I_{OUTLDO2} = 100\mu A$; $C_{OUT1} = C_{OUT2} = 1\mu F$; $T_J = 25^\circ C$, **bold** values indicate -40°C to +125°C, unless noted.

Parameter	Condition	Min.	Typ.	Max.	Units
Output Voltage Accuracy	Variation from nominal V_{OUT}	-2.0		+2.0	%
	Variation from nominal V_{OUT} ; -40°C to +125°C	-3.0		+3.0	%
Line Regulation	$V_{IN} = V_{OUT} + 1V$ to 5.5V, $I_{OUT} = 100\mu A$		0.02	0.3	%/V
Load Regulation	$I_{OUT} = 100\mu A$ to 150mA		0.3	1	%
Dropout Voltage	$I_{OUT} = 50mA$		55	110	mV
	$I_{OUT} = 150mA$		155	310	
Ground Pin Current	$V_{EN1} = \text{High}$; $V_{EN2} = \text{Low}$; $I_{OUT} = 0mA$		32	45	μA
	$V_{EN1} = \text{Low}$; $V_{EN2} = \text{High}$; $I_{OUT} = 0mA$		32	45	
	$V_{EN1} = V_{EN2} = \text{High}$; $I_{OUT1} = I_{OUT2} = 0mA$		57	85	
Ground Pin Current in Shutdown	$V_{EN1} = V_{EN2} = 0V$		0.05	1	μA
Ripple Rejection	$f = 1kHz$; $C_{OUT} = 1\mu F$		60		dB
Current Limit	$V_{OUT} = 0V$	200	325	550	mA
Output Voltage Noise	$C_{OUT} = 1\mu F$, 10Hz to 100kHz		200		μV_{RMS}
Auto-Discharge NFET Resistance	MIC5371 Only; $V_{EN1} = V_{EN2} = 0V$; $V_{IN} = 3.6V$		30		Ω
Enable Inputs (EN1/EN2)					
Enable Input Voltage	Logic Low			0.2	V
	Logic High	1.2			
Enable Input Current	$V_{IL} \leq 0.2V$		0.01	1	μA
	$V_{IH} \geq 1.2V$		0.01	1	
Turn-on Time	$C_{OUT} = 1\mu F$		50	125	μs

Notes:

- Exceeding the absolute maximum rating may damage the device.
- The device is not guaranteed to function outside its operating rating.
- The maximum allowable power dissipation of any T_A (ambient temperature) is $P_{D(max)} = (T_{J(max)} - T_A) / \theta_{JA}$. Exceeding the maximum allowable power dissipation will result in excessive die temperature, and the regulator will go into thermal shutdown.
- Devices are ESD sensitive. Handling precautions recommended. Human body model, 1.5k Ω in series with 100pF.
- Specification for packaged product only.

Typical Characteristics

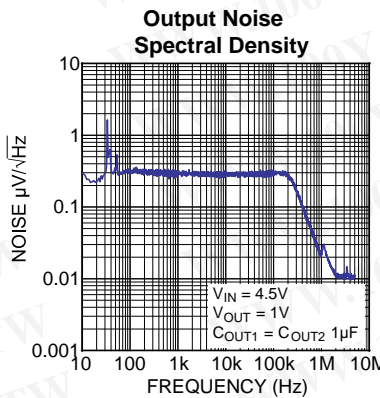
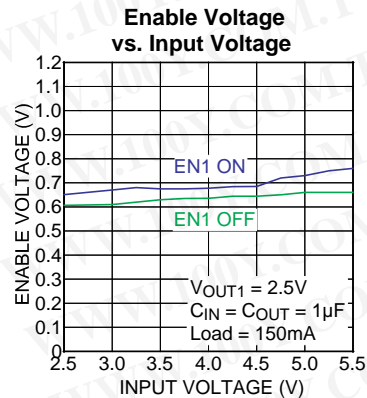
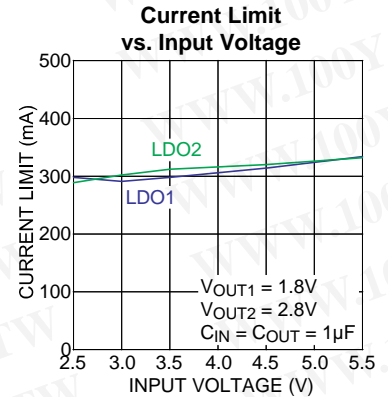
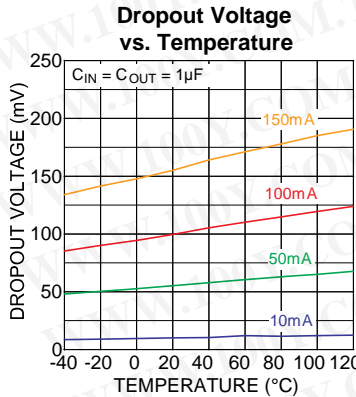
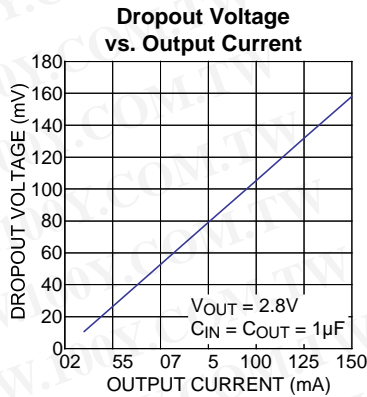
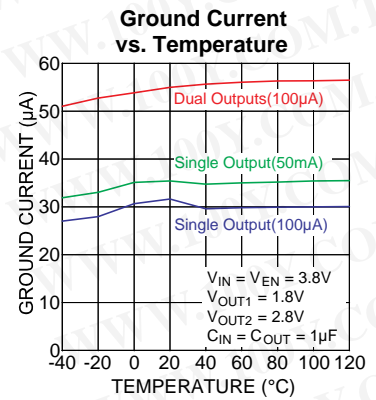
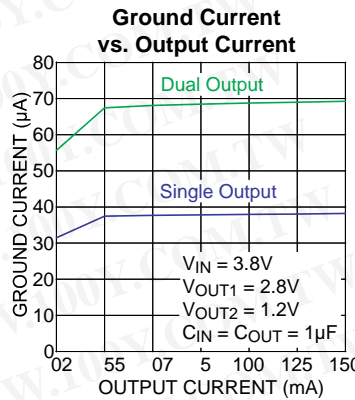
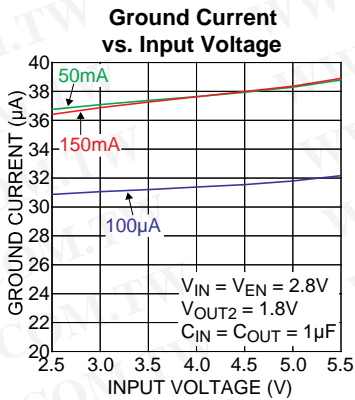
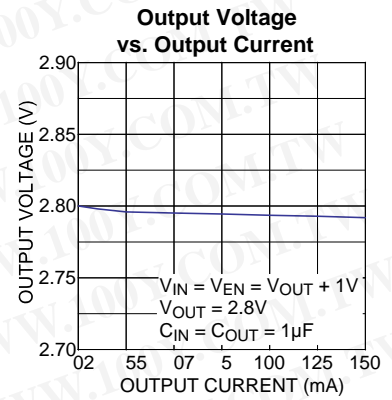
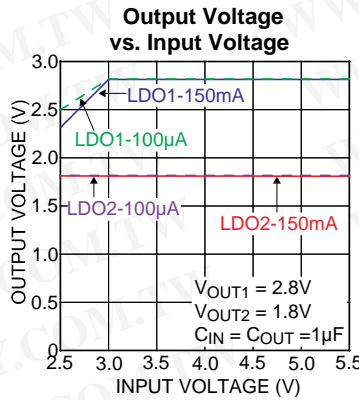
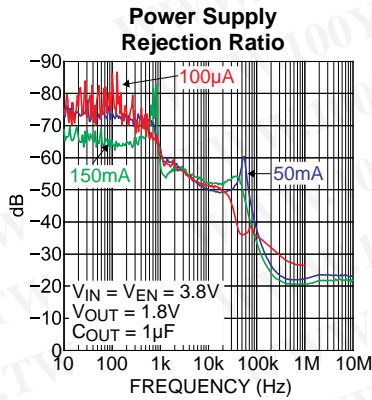

勝特力材料 886-3-5753170
 勝特力电子(上海) 86-21-34970699
 勝特力电子(深圳) 86-755-83298787
[Http://www.100y.com.tw](http://www.100y.com.tw)

Functional Characteristics

Turn-On Time

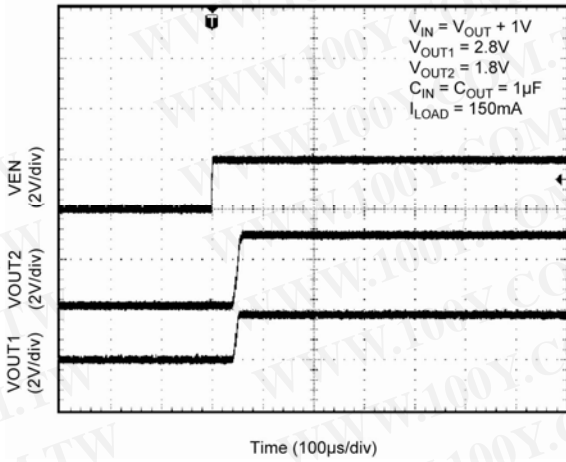

Line Transient

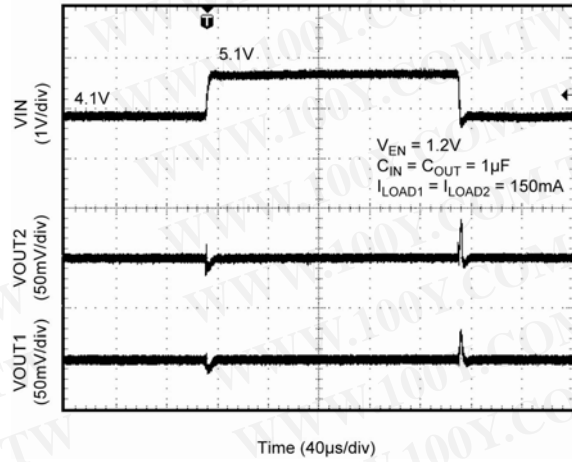

Load Transient

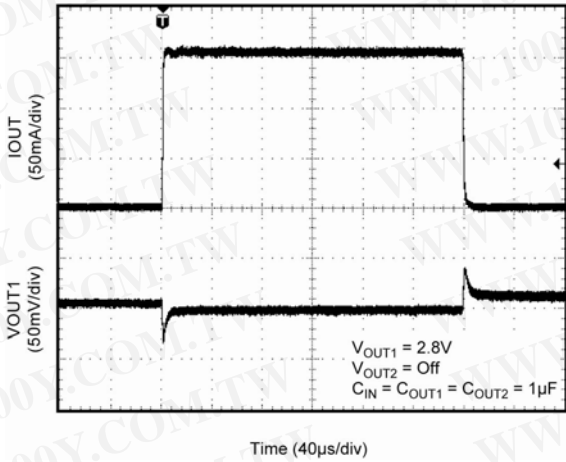

Load Transient

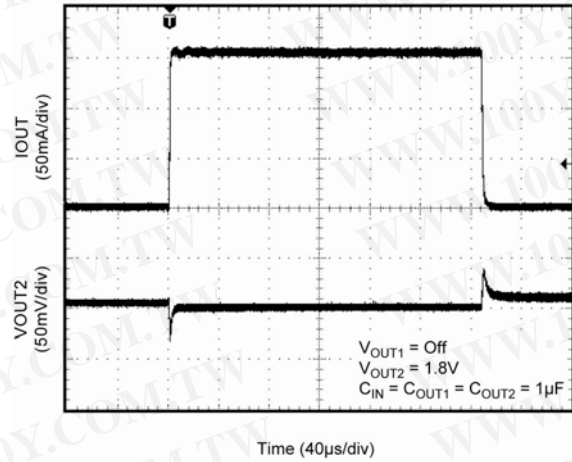

Turn-Off Time

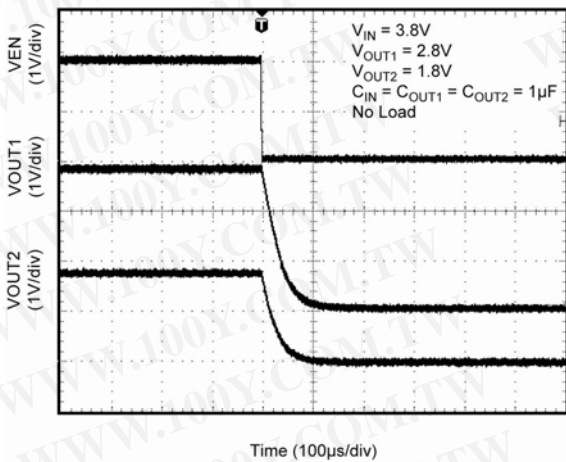

勝特力材料 886-3-5753170
 勝特力电子(上海) 86-21-34970699
 勝特力电子(深圳) 86-755-83298787
[Http://www.100y.com.tw](http://www.100y.com.tw)

Application Information

MIC5370/1 is a dual 150mA LDO in a small 1.6mm x 1.6mm package. The MIC5371 includes an auto-discharge circuit for each of the LDO outputs that are activated when the output is disabled. The MIC5370/1 regulator is fully protected from damage due to fault conditions through linear current limiting and thermal shutdown.

Input Capacitor

The MIC5370/1 is a high-performance, high bandwidth device. An input capacitor of 1 μ F capacitor is required from the input to ground to provide stability. Low-ESR ceramic capacitors provide optimal performance at a minimum of space. Additional high-frequency capacitors, such as small-valued NPO dielectric-type capacitors, help filter out high-frequency noise and are good practice in any RF-based circuit. X5R or X7R dielectrics are recommended for the input capacitor. Y5V dielectrics lose most of their capacitance over temperature and are therefore, not recommended.

Output Capacitor

The MIC5370/1 requires an output capacitor of 1 μ F or greater to maintain stability. The design is optimized for use with low-ESR ceramic chip capacitors. High ESR capacitors may cause high frequency oscillation. The output capacitor can be increased, but performance has been optimized for a 1 μ F ceramic output capacitor and does not improve significantly with larger capacitance.

X7R/X5R dielectric-type ceramic capacitors are recommended because of their temperature performance. X7R-type capacitors change capacitance by 15% over their operating temperature range and are the most stable type of ceramic capacitors. Z5U and Y5V dielectric capacitors change value by as much as 50% and 60%, respectively, over their operating temperature ranges. To use a ceramic chip capacitor with Y5V dielectric, the value must be much higher than an X7R ceramic capacitor to ensure the same minimum capacitance over the equivalent operating temperature range.

No-Load Stability

Unlike many other voltage regulators, the MIC5370/1 will remain stable and in regulation with no load. This is especially important in CMOS RAM keep-alive applications.

Enable/Shutdown

The MIC5370/1 comes with two active-high enable pins that allow each regulator to be disabled independently. Forcing the enable pin low disables the regulator and sends it into a "zero" off-mode-current state. In this state, current consumed by the regulator goes nearly to zero.

When disabled the MIC5371 switches a 30 Ω (typical) load on the regulator output to discharge the external capacitor.

Forcing the enable pin high enables the output voltage. The active-high enable pin uses CMOS technology and the enable pin cannot be left floating; a floating enable pin may cause an indeterminate state on the output.

Thermal Considerations

The MIC5370/1 is designed to provide 150mA of continuous current for both outputs in a very small package. Maximum ambient operating temperature can be calculated based on the output current and the voltage drop across the part. For example if the input voltage is 3.6V, the output voltage is 2.8V for V_{OUT1} , 1.8V for V_{OUT2} and the output current = 150mA. The actual power dissipation of the regulator circuit can be determined using the equation:

$$P_D = (V_{IN} - V_{OUT1}) I_{OUT1} + (V_{IN} - V_{OUT2}) I_{OUT2} + V_{IN} I_{GND}$$

Because this device is CMOS and the ground current is typically <100 μ A over the load range, the power dissipation contributed by the ground current is < 1% and can be ignored for this calculation:

$$P_D = (3.6V - 2.8V) \times 150mA + (3.6V - 1.8) \times 150mA \\ P_D = 0.39W$$

To determine the maximum ambient operating temperature of the package, use the junction-to-ambient thermal resistance of the device and the following basic equation:

$$P_{D(MAX)} = \left(\frac{T_{J(MAX)} - T_A}{\theta_{JA}} \right)$$

$T_{J(max)} = 125^\circ\text{C}$, and the maximum junction temperature of the die, θ_{JA} , thermal resistance = 90°C/W .

Substituting P_D for $P_{D(max)}$ and solving for the ambient operating temperature will give the maximum operating conditions for the regulator circuit. The junction-to-ambient thermal resistance for the minimum footprint is 90°C/W .

The maximum power dissipation must not be exceeded for proper operation.

勝特力材料 886-3-5753170
 勝特力电子(上海) 86-21-34970699
 勝特力电子(深圳) 86-755-83298787

[Http://www.100y.com.tw](http://www.100y.com.tw)

For example, when operating the MIC5370-MGYMT at an input voltage of 3.6V and 150mA loads at each output with a minimum footprint layout, the maximum ambient operating temperature T_A can be determined as follows:

$$0.39W = (125^{\circ}\text{C} - T_A)/(90^{\circ}\text{C/W})$$

$$T_A = 89.9^{\circ}\text{C}$$

Therefore, a 2.8V/1.8V application with 150mA at each output current can accept an ambient operating temperature of 89.9°C in a 1.6mm x 1.6mm MLF[®] package. For a full discussion of heat sinking and thermal effects on voltage regulators, refer to the "Regulator Thermals" section of *Micrel's Designing with Low-Dropout Voltage Regulators* handbook. This information can be found on Micrel's website at:

http://www.micrel.com/PDF/other/LDOBk_ds.pdf

勝特力材料 886-3-5753170
勝特力电子(上海) 86-21-34970699
勝特力电子(深圳) 86-755-83298787
[Http://www.100y.com.tw](http://www.100y.com.tw)

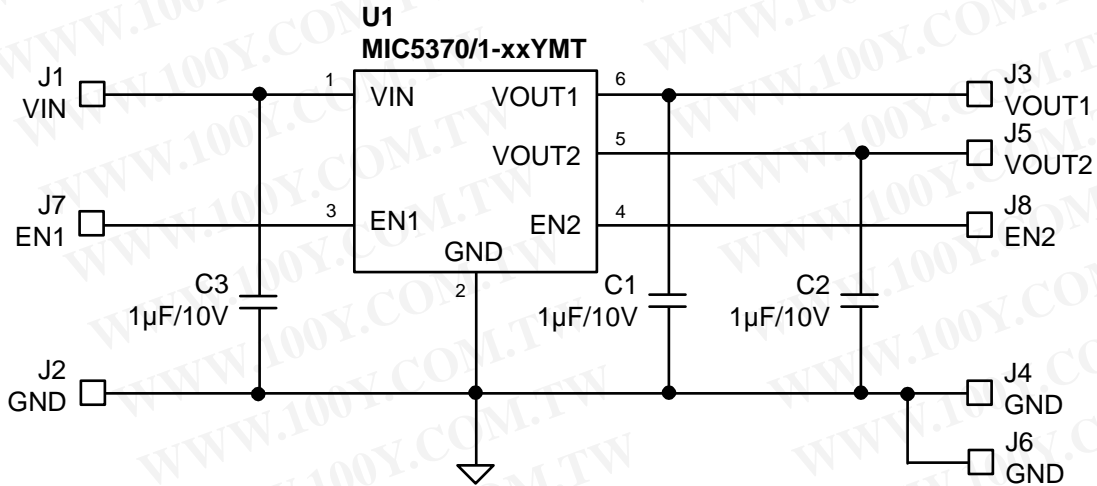

Bill of Materials

Item	Part Number	Manufacturer	Description	Qty.
C1, C2, C3	GRM188R60J225KE19D	Murata ⁽¹⁾	Capacitor, 1µF Ceramic, 10V, X5R, Size 0402	3
U1	MIC5370/1-XXYMT	Micrel ⁽²⁾	Dual, 150mA LDO, Size 1.6mm x 1.6mm Thin MLF®	1

Notes:

- 1. Murata: www.murata.com
- 2. Micrel, Inc.: www.micrel.com

勝特力材料 886-3-5753170
 勝特力电子(上海) 86-21-34970699
 勝特力电子(深圳) 86-755-83298787
[Http://www.100y.com.tw](http://www.100y.com.tw)

PCB Layout Recommendations

勝特力材料 886-3-5753170
 勝特力电子(上海) 86-21-34970699
 勝特力电子(深圳) 86-755-83298787
[Http://www.100y.com.tw](http://www.100y.com.tw)

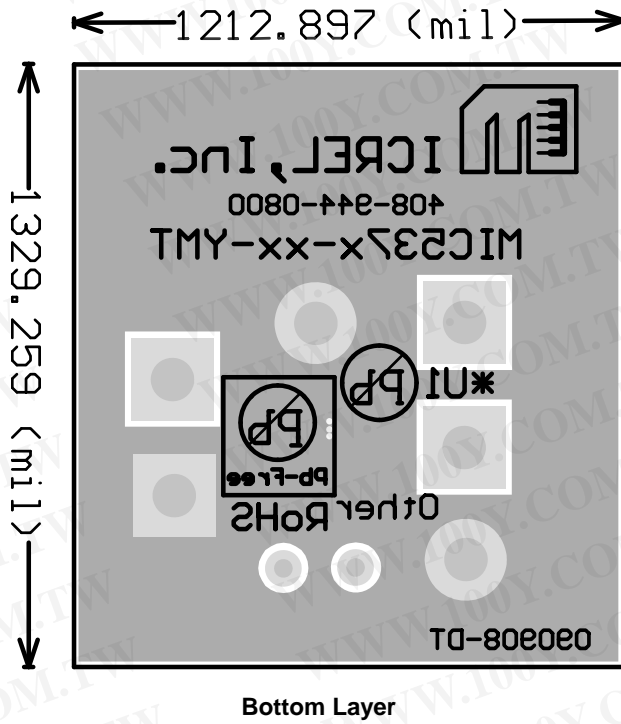
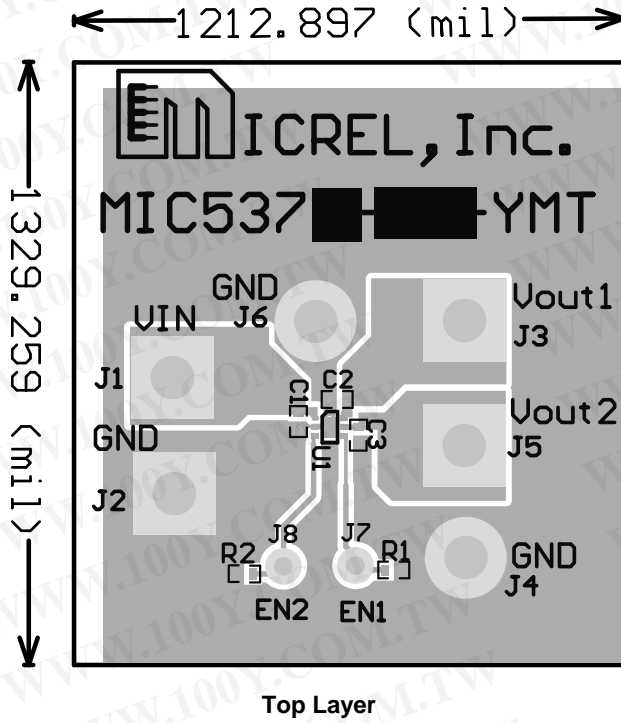

Package Information

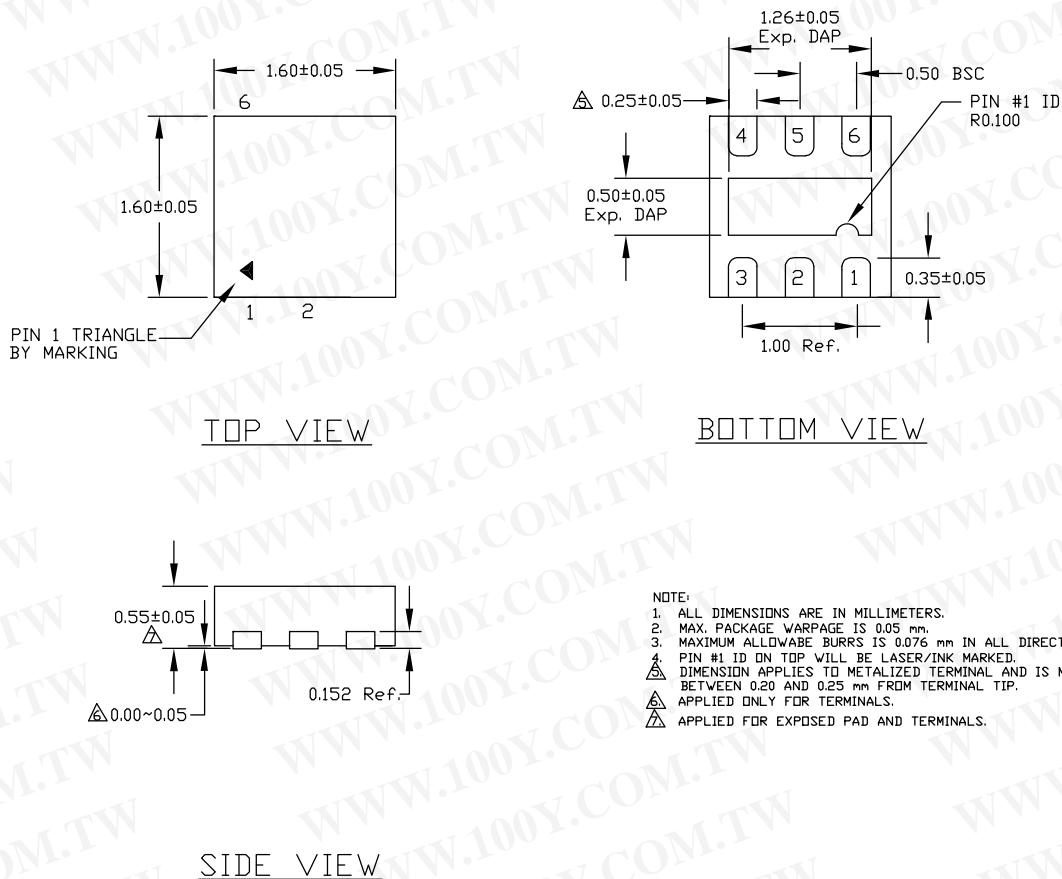

6-Pin 1.6mm x 1.6mm Thin MLF[®] (MT)

MICREL, INC. 2180 FORTUNE DRIVE SAN JOSE, CA 95131 USA
 TEL +1 (408) 944-0800 FAX +1 (408) 474-1000 WEB <http://www.micrel.com>

Micrel makes no representations or warranties with respect to the accuracy or completeness of the information furnished in this data sheet. This information is not intended as a warranty and Micrel does not assume responsibility for its use. Micrel reserves the right to change circuitry, specifications and descriptions at any time without notice. No license, whether express, implied, arising by estoppel or otherwise, to any intellectual property rights is granted by this document. Except as provided in Micrel's terms and conditions of sale for such products, Micrel assumes no liability whatsoever, and Micrel disclaims any express or implied warranty relating to the sale and/or use of Micrel products including liability or warranties relating to fitness for a particular purpose, merchantability, or infringement of any patent, copyright or other intellectual property right.

Micrel Products are not designed or authorized for use as components in life support appliances, devices or systems where malfunction of a product can reasonably be expected to result in personal injury. Life support devices or systems are devices or systems that (a) are intended for surgical implant into the body or (b) support or sustain life, and whose failure to perform can be reasonably expected to result in a significant injury to the user. A Purchaser's use or sale of Micrel Products for use in life support appliances, devices or systems is a Purchaser's own risk and Purchaser agrees to fully indemnify Micrel for any damages resulting from such use or sale.

© 2008 Micrel, Incorporated.