

# BIPOLAR ANALOG INTEGRATED CIRCUIT

# $\mu$ PC29Mxx Series

## THREE TERMINAL LOW DROPOUT VOLTAGE REGULATOR

The  $\mu$ PC29Mxx series of low dropout voltage three terminal positive regulators is constructed with PNP output transistor. The  $\mu$ PC29Mxx series feature the ability to source 0.5 A of output current with a low dropout voltage of typically 0.5 V.

The power dissipation of the  $\mu$ PC29Mxx series can be drastically reduced compared with the conventional three terminal positive voltage regulators that is constructed with NPN output transistor. Also, this series corresponds to the low voltage output (3.0 V, 3.3 V) which is not in the conventional low dropout regulators ( $\mu$ PC24MxxA series).

### FEATURES

- Output current in excess of 0.5 A
- Low dropout voltage  
 $V_{DIF} = 0.5 \text{ V TYP. (I}_o = 0.5 \text{ A)}$
- On-chip over-current and thermal protection circuit
- On-chip output transistor safe operating area protection circuit

<R>

### PIN CONFIGURATIONS (Marking Side)

$\mu$ PC29MxxHF Series: Isolated TO-220 (MP-45G)

$\mu$ PC29MxxHB Series: SC-64 (MP-3)

$\mu$ PC29MxxT Series: SC-63 (MP-3Z)

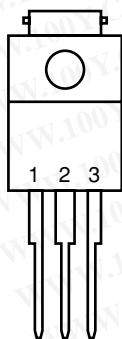

1: INPUT  
2: GND  
3: OUTPUT

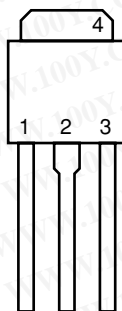

1: INPUT  
2: GND<sup>Note1</sup>  
3: OUTPUT  
4: GND (Fin)

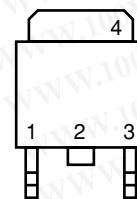

1: INPUT  
2: GND<sup>Note2</sup>  
3: OUTPUT  
4: GND (Fin)

**Notes** 1. No.2 pin and No.4 fin are common GND.

2. No.2 pin is cut. No.2 pin and No.4 fin are common GND.

勝特力材料 886-3-5753170  
 勝特力电子(上海) 86-21-34970699  
 勝特力电子(深圳) 86-755-83298787  
[Http://www.100y.com.tw](http://www.100y.com.tw)

The information in this document is subject to change without notice. Before using this document, please confirm that this is the latest version.  
 Not all products and/or types are available in every country. Please check with an NEC Electronics sales representative for availability and additional information.

BLOCK DIAGRAM

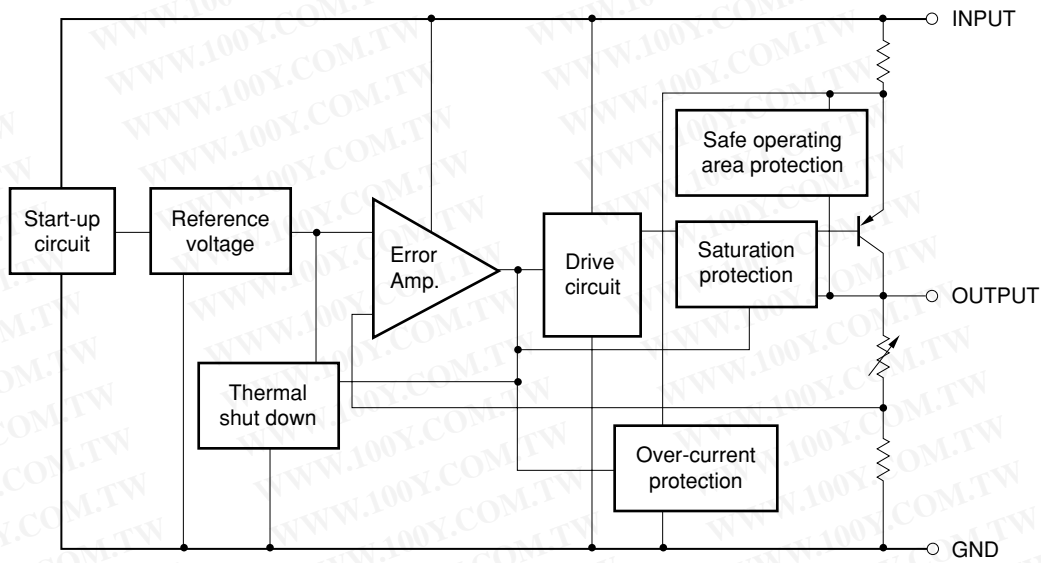

勝特力材料 886-3-5753170  
勝特力电子(上海) 86-21-34970699  
勝特力电子(深圳) 86-755-83298787  
[Http://www.100y.com.tw](http://www.100y.com.tw)

&lt;R&gt;

**ORDERING INFORMATION**

Part Number	Package	Output Voltage	Marking
μPC29M03HF	Isolated TO-220 (MP-45G)	3.0 V	29M03
μPC29M03HB	SC-64 (MP-3)	3.0 V	29M03
μPC29M03T	SC-63 (MP-3Z)	3.0 V	29M03
μPC29M33HF	Isolated TO-220 (MP-45G)	3.3 V	29M33
μPC29M33HB	SC-64 (MP-3)	3.3 V	29M33
μPC29M33T	SC-63 (MP-3Z)	3.3 V	29M33
μPC29M05HF	Isolated TO-220 (MP-45G)	5.0 V	29M05
μPC29M05HB	SC-64 (MP-3)	5.0 V	29M05
μPC29M05T	SC-63 (MP-3Z)	5.0 V	29M05
μPC29M06HF	Isolated TO-220 (MP-45G)	6.0 V	29M06
μPC29M06HB	SC-64 (MP-3)	6.0 V	29M06
μPC29M06T	SC-63 (MP-3Z)	6.0 V	29M06
μPC29M07HF	Isolated TO-220 (MP-45G)	7.0 V	29M07
μPC29M07HB	SC-64 (MP-3)	7.0 V	29M07
μPC29M07T	SC-63 (MP-3Z)	7.0 V	29M07
μPC29M08HF	Isolated TO-220 (MP-45G)	8.0 V	29M08
μPC29M08HB	SC-64 (MP-3)	8.0 V	29M08
μPC29M08T	SC-63 (MP-3Z)	8.0 V	29M08
μPC29M09HF	Isolated TO-220 (MP-45G)	9.0 V	29M09
μPC29M09HB	SC-64 (MP-3)	9.0 V	29M09
μPC29M09T	SC-63 (MP-3Z)	9.0 V	29M09
μPC29M10HF	Isolated TO-220 (MP-45G)	10.0 V	29M10
μPC29M10HB	SC-64 (MP-3)	10.0 V	29M10
μPC29M10T	SC-63 (MP-3Z)	10.0 V	29M10
μPC29M12HF	Isolated TO-220 (MP-45G)	12.0 V	29M12
μPC29M12HB	SC-64 (MP-3)	12.0 V	29M12
μPC29M12T	SC-63 (MP-3Z)	12.0 V	29M12

**Remark** Tape-packaged products have the symbol -E1, or -E2 suffixed to the part number. Pb-free products have the symbol -AZ, or -AY suffixed to the part number. Refer to the following table for details.

勝特力材料 886-3-5753170  
 勝特力电子(上海) 86-21-34970699  
 勝特力电子(深圳) 86-755-83298787  
[Http://www.100y.com.tw](http://www.100y.com.tw)

Part Number <sup>Note1</sup>	Package	Package Type
μPC29MxxHF	Isolated TO-220 (MP-45G)	• Packed in envelop
μPC29MxxHF-AZ <sup>Note2</sup>	Isolated TO-220 (MP-45G)	• Packed in envelop
μPC29MxxHB	SC-64 (MP-3)	• Packed in envelop
μPC29MxxHB-AZ <sup>Note2</sup>	SC-64 (MP-3)	• Packed in envelop
μPC29MxxHB-AY <sup>Note3</sup>	SC-64 (MP-3)	• Packed in envelop
μPC29MxxT-E1	SC-63 (MP-3Z)	• 16 mm wide embossed taping • Pin 1 on draw-out side • 2000 pcs/reel
μPC29MxxT-E1-AZ <sup>Note2</sup>	SC-63 (MP-3Z)	• 16 mm wide embossed taping • Pin 1 on draw-out side • 2000 pcs/reel
μPC29MxxT-E1-AY <sup>Note3</sup>	SC-63 (MP-3Z)	• 16 mm wide embossed taping • Pin 1 on draw-out side • 2000 pcs/reel
μPC29MxxT-E2	SC-63 (MP-3Z)	• 16 mm wide embossed taping • Pin 1 at take-up side • 2000 pcs/reel
μPC29MxxT-E2-AZ <sup>Note2</sup>	SC-63 (MP-3Z)	• 16 mm wide embossed taping • Pin 1 at take-up side • 2000 pcs/reel
μPC29MxxT-E2-AY <sup>Note3</sup>	SC-63 (MP-3Z)	• 16 mm wide embossed taping • Pin 1 at take-up side • 2000 pcs/reel

**Notes 1.** xx stands for symbols that indicate the output voltage.

**2.** Pb-free (This product does not contain Pb in the external electrode.)

**3.** Pb-free (This product does not contain Pb in the external electrode, Sn100% plating.)

勝特力材料 886-3-5753170  
 勝特力电子(上海) 86-21-34970699  
 勝特力电子(深圳) 86-755-83298787  
[Http://www.100y.com.tw](http://www.100y.com.tw)



**ABSOLUTE MAXIMUM RATINGS (T<sub>A</sub> = 25°C, Unless otherwise specified.)**

Parameter	Symbol	Rating		Unit
		μPC29MxxHF	μPC29MxxHB, μPC29MxxT	
Input Voltage	V <sub>IN</sub>	20		V
Internal Power Dissipation (T <sub>C</sub> = 25°C) <sup>Note</sup>	P <sub>T</sub>	15	10	W
Operating Ambient Temperature	T <sub>A</sub>	-30 to +85		°C
Operating Junction Temperature	T <sub>J</sub>	-30 to +150		°C
Storage Temperature	T <sub>stg</sub>	-55 to +150		°C
Thermal Resistance (Junction to Case)	R <sub>th (J-C)</sub>	7	12.5	°C/W
Thermal Resistance (Junction to Ambient)	R <sub>th (J-A)</sub>	65	125	°C/W

**Note** Internally limited. When the operating junction temperature rises above 150°C, the internal circuit shuts down the output voltage.

**Caution** Product quality may suffer if the absolute maximum rating is exceeded even momentarily for any parameter. That is, the absolute maximum ratings are rated values at which the product is on the verge of suffering physical damage, and therefore the product must be used under conditions that ensure that the absolute maximum ratings are not exceeded.

**TYPICAL CONNECTION**

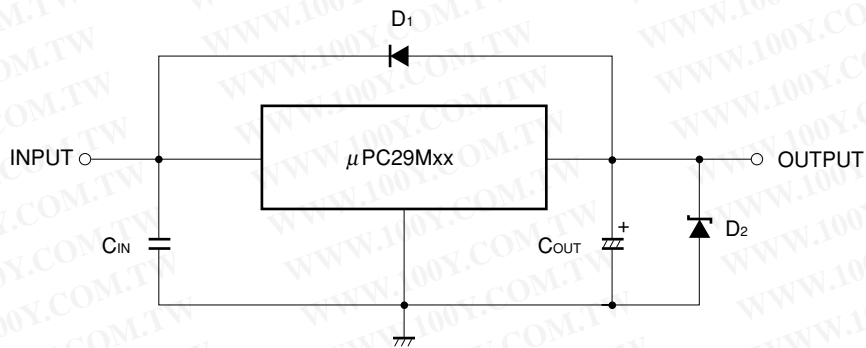

- C<sub>IN</sub> : 0.1 μF or higher. Be sure to connect C<sub>IN</sub> to prevent parasitic oscillation. Set this value according to the length of the line between the regulator and the INPUT pin. Use of a film capacitor or other capacitor with first-rate voltage and temperature characteristics is recommended. If using a laminated ceramic capacitor, it is necessary to ensure that C<sub>IN</sub> is 0.1 μF or higher for the voltage and temperature range to be used.
- C<sub>OUT</sub> : 47 μF or higher. Be sure to connect C<sub>OUT</sub> to prevent oscillation and improve excessive load regulation. Place C<sub>IN</sub> and C<sub>OUT</sub> as close as possible to the IC pins (within 1 to 2 cm). Also, use an electrolytic capacitor with low impedance characteristics if considering use at sub-zero temperatures.
- D<sub>1</sub> : If the OUTPUT pin has a higher voltage than the INPUT pin, connect a diode.
- D<sub>2</sub> : If the OUTPUT pin has a lower voltage than the GND pin, connect a Schottky barrier diode.

**Caution** Make sure that no voltage is applied to the OUTPUT pin from external.

勝特力材料 886-3-5753170  
 勝特力电子(上海) 86-21-34970699  
 勝特力电子(深圳) 86-755-83298787  
[Http://www.100y.com.tw](http://www.100y.com.tw)

RECOMMENDED OPERATING CONDITIONS

Parameter	Symbol	Type Number	MIN.	TYP.	MAX.	Unit
Input Voltage	V <sub>IN</sub>	μPC29M03	4		16	V
		μPC29M33	4.3		16	
		μPC29M05	6		16	
		μPC29M06	7		16	
		μPC29M07	8		16	
		μPC29M08	9		18	
		μPC29M09	10		18	
		μPC29M10	11		18	
μPC29M12	13		18			
Output Current	I <sub>o</sub>	all	0		0.5	A
Operating Ambient Temperature	T <sub>A</sub>	all	-30		+85	°C
Operating Junction Temperature	T <sub>J</sub>	all	-30		+125	°C

ELECTRICAL CHARACTERISTICS

μPC29M03 (T<sub>J</sub> = 25°C, V<sub>IN</sub> = 5 V, I<sub>o</sub> = 350 mA, C<sub>IN</sub> = 0.22 μF, C<sub>OUT</sub> = 47 μF, unless otherwise specified.)

Parameters	Symbol	Conditions	MIN.	TYP.	MAX.	Unit
Output Voltage	V <sub>o</sub>		2.88	3.0	3.12	V
		0°C ≤ T <sub>J</sub> ≤ 125°C, 4.0 V ≤ V <sub>IN</sub> ≤ 16 V, 0 A ≤ I <sub>o</sub> ≤ 350 mA	2.85		3.15	
		0°C ≤ T <sub>J</sub> ≤ 125°C, 0 A ≤ I <sub>o</sub> ≤ 0.5 A				
Line Regulation	REG <sub>IN</sub>	4.0 V ≤ V <sub>IN</sub> ≤ 16 V		7	30	mV
Load Regulation	REG <sub>L</sub>	0 A ≤ I <sub>o</sub> ≤ 0.5 A		8	30	mV
Quiescent Current	I <sub>BIAS</sub>	I <sub>o</sub> = 0 A		1.8	4.0	mA
		I <sub>o</sub> = 0.5 A		17	30	
Startup Quiescent Current	I <sub>BIAS (s)</sub>	V <sub>IN</sub> = 2.95 V, I <sub>o</sub> = 0 A		7	30	mA
		V <sub>IN</sub> = 2.95 V, I <sub>o</sub> = 0.5 A			80	
Quiescent Current Change	ΔI <sub>BIAS</sub>	0°C ≤ T <sub>J</sub> ≤ 125°C, 4.0 V ≤ V <sub>IN</sub> ≤ 16 V		3.2	20	mA
Output Noise Voltage	V <sub>n</sub>	10 Hz ≤ f ≤ 100 kHz		51		μV <sub>r.m.s.</sub>
Ripple Rejection	R·R	f = 120 Hz, 4.0 V ≤ V <sub>IN</sub> ≤ 16 V	48	64		dB
Dropout Voltage	V <sub>DIF</sub>	0°C ≤ T <sub>J</sub> ≤ 125°C, I <sub>o</sub> = 0.5 A		0.5	1.0	V
Short Circuit Current	I <sub>o short</sub>	V <sub>IN</sub> = 4.5 V	0.65	1.0	1.5	A
		V <sub>IN</sub> = 16 V		0.6		
Peak Output Current	I <sub>o peak</sub>	V <sub>IN</sub> = 4.5 V	0.7	1.0	1.5	A
		V <sub>IN</sub> = 16 V	0.6	0.9	1.5	
Temperature Coefficient of Output Voltage	ΔV <sub>o</sub> /ΔT	0°C ≤ T <sub>J</sub> ≤ 125°C, I <sub>o</sub> = 5 mA		-0.3		mV/°C

勝特力材料 886-3-5753170  
 勝特力电子(上海) 86-21-34970699  
 勝特力电子(深圳) 86-755-83298787  
[Http://www.100y.com.tw](http://www.100y.com.tw)

μPC29M33 (T<sub>J</sub> = 25°C, V<sub>IN</sub> = 5 V, I<sub>o</sub> = 350 mA, C<sub>IN</sub> = 0.22 μF, C<sub>OUT</sub> = 47 μF, unless otherwise specified.)

Parameters	Symbol	Conditions	MIN.	TYP.	MAX.	Unit
Output Voltage	V <sub>O</sub>		3.17	3.3	3.43	V
		0°C ≤ T <sub>J</sub> ≤ 125°C, 4.3 V ≤ V <sub>IN</sub> ≤ 16 V, 0 A ≤ I <sub>o</sub> ≤ 350 mA	3.14		3.46	
		0°C ≤ T <sub>J</sub> ≤ 125°C, 0 A ≤ I <sub>o</sub> ≤ 0.5 A				
Line Regulation	REG <sub>IN</sub>	4.3 V ≤ V <sub>IN</sub> ≤ 16 V		8	33	mV
Load Regulation	REG <sub>L</sub>	0 A ≤ I <sub>o</sub> ≤ 0.5 A		10	33	mV
Quiescent Current	I <sub>BIAS</sub>	I <sub>o</sub> = 0 A		1.8	4.0	mA
		I <sub>o</sub> = 0.5 A		15	30	
Startup Quiescent Current	I <sub>BIAS</sub> (s)	V <sub>IN</sub> = 3.1 V, I <sub>o</sub> = 0 A		9	30	mA
		V <sub>IN</sub> = 3.1 V, I <sub>o</sub> = 0.5 A			80	
Quiescent Current Change	ΔI <sub>BIAS</sub>	0°C ≤ T <sub>J</sub> ≤ 125°C, 4.3 V ≤ V <sub>IN</sub> ≤ 16 V		2.9	20	mA
Output Noise Voltage	V <sub>n</sub>	10 Hz ≤ f ≤ 100 kHz		56		μV <sub>r.m.s.</sub>
Ripple Rejection	R·R	f = 120 Hz, 4.3 V ≤ V <sub>IN</sub> ≤ 16 V	48	64		dB
Dropout Voltage	V <sub>DIF</sub>	0°C ≤ T <sub>J</sub> ≤ 125°C, I <sub>o</sub> = 0.5 A		0.5	1.0	V
Short Circuit Current	I <sub>O short</sub>	V <sub>IN</sub> = 4.5 V	0.7	1.1	1.5	A
		V <sub>IN</sub> = 16 V		0.6		
Peak Output Current	I <sub>o peak</sub>	V <sub>IN</sub> = 4.5 V	0.7	1.2	1.5	A
		V <sub>IN</sub> = 16 V	0.6	1.0	1.5	
Temperature Coefficient of Output Voltage	ΔV <sub>O</sub> /ΔT	0°C ≤ T <sub>J</sub> ≤ 125°C, I <sub>o</sub> = 5 mA		-0.4		mV/°C

勝特力材料 886-3-5753170  
 勝特力电子(上海) 86-21-34970699  
 勝特力电子(深圳) 86-755-83298787  
[Http://www.100y.com.tw](http://www.100y.com.tw)

μPC29M05 (T<sub>J</sub> = 25°C, V<sub>IN</sub> = 8 V, I<sub>o</sub> = 350 mA, C<sub>IN</sub> = 0.22 μF, C<sub>OUT</sub> = 47 μF, unless otherwise specified.)

Parameters	Symbol	Conditions	MIN.	TYP.	MAX.	Unit
Output Voltage	V <sub>O</sub>		4.8	5.0	5.2	V
		0°C ≤ T <sub>J</sub> ≤ 125°C, 6 V ≤ V <sub>IN</sub> ≤ 16 V, 0 A ≤ I <sub>o</sub> ≤ 350 mA	4.75		5.25	
		0°C ≤ T <sub>J</sub> ≤ 125°C, 0 A ≤ I <sub>o</sub> ≤ 0.5 A				
Line Regulation	REG <sub>IN</sub>	6 V ≤ V <sub>IN</sub> ≤ 16 V		26	50	mV
Load Regulation	REG <sub>L</sub>	0 A ≤ I <sub>o</sub> ≤ 0.5 A		17	50	mV
Quiescent Current	I <sub>BIAS</sub>	I <sub>o</sub> = 0 A		1.9	4.0	mA
		I <sub>o</sub> = 0.5 A		16	30	
Startup Quiescent Current	I <sub>BIAS (s)</sub>	V <sub>IN</sub> = 4.5 V, I <sub>o</sub> = 0 A		10	30	mA
		V <sub>IN</sub> = 4.5 V, I <sub>o</sub> = 0.5 A			80	
Quiescent Current Change	ΔI <sub>BIAS</sub>	0°C ≤ T <sub>J</sub> ≤ 125°C, 6 V ≤ V <sub>IN</sub> ≤ 16 V		2.4	20	mA
Output Noise Voltage	V <sub>n</sub>	10 Hz ≤ f ≤ 100 kHz		87		μV <sub>r.m.s.</sub>
Ripple Rejection	R·R	f = 120 Hz, 6 V ≤ V <sub>IN</sub> ≤ 16 V	46	60		dB
Dropout Voltage	V <sub>DIF</sub>	0°C ≤ T <sub>J</sub> ≤ 125°C, I <sub>o</sub> = 0.5 A		0.5	1.0	V
Short Circuit Current	I <sub>o short</sub>	V <sub>IN</sub> = 6.5 V	0.65	1.1	1.5	A
		V <sub>IN</sub> = 16 V		0.6		
Peak Output Current	I <sub>o peak</sub>	V <sub>IN</sub> = 6.5 V	0.7	1.2	1.5	A
		V <sub>IN</sub> = 16 V	0.6	1.1	1.5	
Temperature Coefficient of Output Voltage	ΔV <sub>O</sub> /ΔT	0°C ≤ T <sub>J</sub> ≤ 125°C, I <sub>o</sub> = 5 mA		0.7		mV/°C

勝特力材料 886-3-5753170  
 勝特力电子(上海) 86-21-34970699  
 勝特力电子(深圳) 86-755-83298787  
[Http://www.100y.com.tw](http://www.100y.com.tw)



μPC29M06 (T<sub>J</sub> = 25°C, V<sub>IN</sub> = 9 V, I<sub>o</sub> = 350 mA, C<sub>IN</sub> = 0.22 μF, C<sub>OUT</sub> = 47 μF, unless otherwise specified.)

Parameters	Symbol	Conditions	MIN.	TYP.	MAX.	Unit
Output Voltage	V <sub>O</sub>		5.76	6.0	6.24	V
		0°C ≤ T <sub>J</sub> ≤ 125°C, 7 V ≤ V <sub>IN</sub> ≤ 16 V, 0 A ≤ I <sub>o</sub> ≤ 350 mA	5.70		6.30	
		0°C ≤ T <sub>J</sub> ≤ 125°C, 0 A ≤ I <sub>o</sub> ≤ 0.5 A				
Line Regulation	REG <sub>IN</sub>	7 V ≤ V <sub>IN</sub> ≤ 16 V		30	60	mV
Load Regulation	REG <sub>L</sub>	0 A ≤ I <sub>o</sub> ≤ 0.5 A		30	60	mV
Quiescent Current	I <sub>BIAS</sub>	I <sub>o</sub> = 0 A		2.0	4.0	mA
		I <sub>o</sub> = 0.5 A		16	30	
Startup Quiescent Current	I <sub>BIAS</sub> (s)	V <sub>IN</sub> = 5.5 V, I <sub>o</sub> = 0 A		10	30	mA
		V <sub>IN</sub> = 5.5 V, I <sub>o</sub> = 0.5 A			80	
Quiescent Current Change	ΔI <sub>BIAS</sub>	0°C ≤ T <sub>J</sub> ≤ 125°C, 7 V ≤ V <sub>IN</sub> ≤ 16 V		2.5	20	mA
Output Noise Voltage	V <sub>n</sub>	10 Hz ≤ f ≤ 100 kHz		126		μV <sub>r.m.s.</sub>
Ripple Rejection	R·R	f = 120 Hz, 7 V ≤ V <sub>IN</sub> ≤ 16 V	42	58		dB
Dropout Voltage	V <sub>DIF</sub>	0°C ≤ T <sub>J</sub> ≤ 125°C, I <sub>o</sub> = 0.5 A		0.5	1.0	V
Short Circuit Current	I <sub>O short</sub>	V <sub>IN</sub> = 7.5 V	0.7	1.1	1.5	A
		V <sub>IN</sub> = 16 V		0.6		
Peak Output Current	I <sub>o peak</sub>	V <sub>IN</sub> = 7.5 V	0.7	1.1	1.5	A
		V <sub>IN</sub> = 16 V	0.6	1.1	1.5	
Temperature Coefficient of Output Voltage	ΔV <sub>O</sub> /ΔT	0°C ≤ T <sub>J</sub> ≤ 125°C, I <sub>o</sub> = 5 mA		0.44		mV/°C

勝特力材料 886-3-5753170  
 勝特力电子(上海) 86-21-34970699  
 勝特力电子(深圳) 86-755-83298787  
[Http://www.100y.com.tw](http://www.100y.com.tw)

μPC29M07 (T<sub>J</sub> = 25°C, V<sub>IN</sub> = 10 V, I<sub>o</sub> = 350 mA, C<sub>IN</sub> = 0.22 μF, C<sub>OUT</sub> = 47 μF, unless otherwise specified.)

Parameters	Symbol	Conditions	MIN.	TYP.	MAX.	Unit
Output Voltage	V <sub>O</sub>		6.72	7.0	7.28	V
		0°C ≤ T <sub>J</sub> ≤ 125°C, 8 V ≤ V <sub>IN</sub> ≤ 16 V, 0 A ≤ I <sub>o</sub> ≤ 350 mA	6.65		7.35	
		0°C ≤ T <sub>J</sub> ≤ 125°C, 0 A ≤ I <sub>o</sub> ≤ 0.5 A				
Line Regulation	REG <sub>IN</sub>	8 V ≤ V <sub>IN</sub> ≤ 16 V		35	70	mV
Load Regulation	REG <sub>L</sub>	0 A ≤ I <sub>o</sub> ≤ 0.5 A		35	70	mV
Quiescent Current	I <sub>BIAS</sub>	I <sub>o</sub> = 0 A		2.0	4.0	mA
		I <sub>o</sub> = 0.5 A		16	30	
Startup Quiescent Current	I <sub>BIAS (s)</sub>	V <sub>IN</sub> = 6.5 V, I <sub>o</sub> = 0 A		10	30	mA
		V <sub>IN</sub> = 6.5 V, I <sub>o</sub> = 0.5 A			80	
Quiescent Current Change	ΔI <sub>BIAS</sub>	0°C ≤ T <sub>J</sub> ≤ 125°C, 8 V ≤ V <sub>IN</sub> ≤ 16 V		2.6	20	mA
Output Noise Voltage	V <sub>n</sub>	10 Hz ≤ f ≤ 100 kHz		147		μV <sub>r.m.s.</sub>
Ripple Rejection	R·R	f = 120 Hz, 8 V ≤ V <sub>IN</sub> ≤ 16 V	40	56		dB
Dropout Voltage	V <sub>DIF</sub>	0°C ≤ T <sub>J</sub> ≤ 125°C, I <sub>o</sub> = 0.5 A		0.5	1.0	V
Short Circuit Current	I <sub>O short</sub>	V <sub>IN</sub> = 8.5 V	0.7	1.1	1.5	A
		V <sub>IN</sub> = 16 V		0.6		
Peak Output Current	I <sub>o peak</sub>	V <sub>IN</sub> = 8.5 V	0.7	1.2	1.5	A
		V <sub>IN</sub> = 16 V	0.6	1.1	1.5	
Temperature Coefficient of Output Voltage	ΔV <sub>O</sub> /ΔT	0°C ≤ T <sub>J</sub> ≤ 125°C, I <sub>o</sub> = 5 mA		0.7		mV/°C

勝特力材料 886-3-5753170  
 勝特力电子(上海) 86-21-34970699  
 勝特力电子(深圳) 86-755-83298787  
[Http://www.100y.com.tw](http://www.100y.com.tw)

μPC29M08 (T<sub>J</sub> = 25°C, V<sub>IN</sub> = 11 V, I<sub>o</sub> = 350 mA, C<sub>IN</sub> = 0.22 μF, C<sub>OUT</sub> = 47 μF, unless otherwise specified.)

Parameters	Symbol	Conditions	MIN.	TYP.	MAX.	Unit
Output Voltage	V <sub>o</sub>		7.68	8.0	8.32	V
		0°C ≤ T <sub>J</sub> ≤ 125°C, 9 V ≤ V <sub>IN</sub> ≤ 18 V, 0 A ≤ I <sub>o</sub> ≤ 350 mA	7.6		8.4	
		0°C ≤ T <sub>J</sub> ≤ 125°C, 0 A ≤ I <sub>o</sub> ≤ 0.5 A				
Line Regulation	REG <sub>IN</sub>	9 V ≤ V <sub>IN</sub> ≤ 18 V		40	80	mV
Load Regulation	REG <sub>L</sub>	0 A ≤ I <sub>o</sub> ≤ 0.5 A		40	80	mV
Quiescent Current	I <sub>BIAS</sub>	I <sub>o</sub> = 0 A		2.0	4.0	mA
		I <sub>o</sub> = 0.5 A		15	30	
Startup Quiescent Current	I <sub>BIAS</sub> (s)	V <sub>IN</sub> = 7.5 V, I <sub>o</sub> = 0 A		10	30	mA
		V <sub>IN</sub> = 7.5 V, I <sub>o</sub> = 0.5 A			80	
Quiescent Current Change	ΔI <sub>BIAS</sub>	0°C ≤ T <sub>J</sub> ≤ 125°C, 9 V ≤ V <sub>IN</sub> ≤ 18 V		3.0	20	mA
Output Noise Voltage	V <sub>n</sub>	10 Hz ≤ f ≤ 100 kHz		150		μV <sub>r.m.s.</sub>
Ripple Rejection	R·R	f = 120 Hz, 9 V ≤ V <sub>IN</sub> ≤ 18 V	42	58		dB
Dropout Voltage	V <sub>DIF</sub>	0°C ≤ T <sub>J</sub> ≤ 125°C, I <sub>o</sub> = 0.5 A		0.5	1.0	V
Short Circuit Current	I <sub>o short</sub>	V <sub>IN</sub> = 9.5 V		1.0		A
		V <sub>IN</sub> = 18 V		0.55		
Peak Output Current	I <sub>o peak</sub>	V <sub>IN</sub> = 9.5 V	0.7	1.2	1.5	A
		V <sub>IN</sub> = 18 V	0.6	1.1	1.5	
Temperature Coefficient of Output Voltage	ΔV <sub>o</sub> /ΔT	0°C ≤ T <sub>J</sub> ≤ 125°C, I <sub>o</sub> = 5 mA		0.7		mV/°C

勝特力材料 886-3-5753170  
 勝特力电子(上海) 86-21-34970699  
 勝特力电子(深圳) 86-755-83298787  
[Http://www.100y.com.tw](http://www.100y.com.tw)

μPC29M09 (T<sub>J</sub> = 25°C, V<sub>IN</sub> = 12 V, I<sub>o</sub> = 350 mA, C<sub>IN</sub> = 0.22 μF, C<sub>OUT</sub> = 47 μF, unless otherwise specified.)

Parameters	Symbol	Conditions	MIN.	TYP.	MAX.	Unit
Output Voltage	V <sub>O</sub>		8.64	9.0	9.36	V
		0°C ≤ T <sub>J</sub> ≤ 125°C, 10 V ≤ V <sub>IN</sub> ≤ 18 V, 0 A ≤ I <sub>o</sub> ≤ 350 mA	8.55		9.45	
		0°C ≤ T <sub>J</sub> ≤ 125°C, 0 A ≤ I <sub>o</sub> ≤ 0.5 A				
Line Regulation	REG <sub>IN</sub>	10 V ≤ V <sub>IN</sub> ≤ 18 V		45	90	mV
Load Regulation	REG <sub>L</sub>	0 A ≤ I <sub>o</sub> ≤ 0.5 A		45	90	mV
Quiescent Current	I <sub>BIAS</sub>	I <sub>o</sub> = 0 A		2.0	4.0	mA
		I <sub>o</sub> = 0.5 A		15	30	
Startup Quiescent Current	I <sub>BIAS (s)</sub>	V <sub>IN</sub> = 8.5 V, I <sub>o</sub> = 0 A		10	30	mA
		V <sub>IN</sub> = 8.5 V, I <sub>o</sub> = 0.5 A			80	
Quiescent Current Change	ΔI <sub>BIAS</sub>	0°C ≤ T <sub>J</sub> ≤ 125°C, 10 V ≤ V <sub>IN</sub> ≤ 18 V			20	mA
Output Noise Voltage	V <sub>n</sub>	10 Hz ≤ f ≤ 100 kHz		170		μV <sub>r.m.s.</sub>
Ripple Rejection	R-R	f = 120 Hz, 10 V ≤ V <sub>IN</sub> ≤ 18 V	41	57		dB
Dropout Voltage	V <sub>DIF</sub>	0°C ≤ T <sub>J</sub> ≤ 125°C, I <sub>o</sub> = 0.5 A		0.5	1.0	V
Short Circuit Current	I <sub>O short</sub>	V <sub>IN</sub> = 10.5 V		1.0		A
		V <sub>IN</sub> = 18 V		0.55		
Peak Output Current	I <sub>o peak</sub>	V <sub>IN</sub> = 10.5 V	0.7	1.2	1.5	A
		V <sub>IN</sub> = 18 V	0.6	1.1	1.5	
Temperature Coefficient of Output Voltage	ΔV <sub>O</sub> /ΔT	0°C ≤ T <sub>J</sub> ≤ 125°C, I <sub>o</sub> = 5 mA		0.8		mV/°C

勝特力材料 886-3-5753170  
 勝特力电子(上海) 86-21-34970699  
 勝特力电子(深圳) 86-755-83298787  
[Http://www.100y.com.tw](http://www.100y.com.tw)



μPC29M10 (T<sub>J</sub> = 25°C, V<sub>IN</sub> = 13 V, I<sub>o</sub> = 350 mA, C<sub>IN</sub> = 0.22 μF, C<sub>OUT</sub> = 47 μF, unless otherwise specified.)

Parameters	Symbol	Conditions	MIN.	TYP.	MAX.	Unit
Output Voltage	V <sub>o</sub>		9.6	10.0	10.4	V
		0°C ≤ T <sub>J</sub> ≤ 125°C, 11 V ≤ V <sub>IN</sub> ≤ 18 V, 0 A ≤ I <sub>o</sub> ≤ 350 mA	9.5		10.5	
		0°C ≤ T <sub>J</sub> ≤ 125°C, 0 A ≤ I <sub>o</sub> ≤ 0.5 A				
Line Regulation	REG <sub>IN</sub>	11 V ≤ V <sub>IN</sub> ≤ 18 V		34	100	mV
Load Regulation	REG <sub>L</sub>	0 A ≤ I <sub>o</sub> ≤ 0.5 A		10	100	mV
Quiescent Current	I <sub>BIAS</sub>	I <sub>o</sub> = 0 A		2.1	4.0	mA
		I <sub>o</sub> = 0.5 A		16	30	
Startup Quiescent Current	I <sub>BIAS</sub> (s)	V <sub>IN</sub> = 9.5 V, I <sub>o</sub> = 0 A		10	30	mA
		V <sub>IN</sub> = 9.5 V, I <sub>o</sub> = 0.5 A			80	
Quiescent Current Change	ΔI <sub>BIAS</sub>	0°C ≤ T <sub>J</sub> ≤ 125°C, 11 V ≤ V <sub>IN</sub> ≤ 18 V		1.9	20	mA
Output Noise Voltage	V <sub>n</sub>	10 Hz ≤ f ≤ 100 kHz		180		μV <sub>r.m.s.</sub>
Ripple Rejection	R·R	f = 120 Hz, 11 V ≤ V <sub>IN</sub> ≤ 18 V	40	53		dB
Dropout Voltage	V <sub>DIF</sub>	0°C ≤ T <sub>J</sub> ≤ 125°C, I <sub>o</sub> = 0.5 A		0.5	1.0	V
Short Circuit Current	I <sub>o short</sub>	V <sub>IN</sub> = 11.5 V		0.9		A
		V <sub>IN</sub> = 18 V		0.5		
Peak Output Current	I <sub>o peak</sub>	V <sub>IN</sub> = 11.5 V	0.7	1.2	1.5	A
		V <sub>IN</sub> = 18 V	0.6	1.2	1.5	
Temperature Coefficient of Output Voltage	ΔV <sub>o</sub> /ΔT	0°C ≤ T <sub>J</sub> ≤ 125°C, I <sub>o</sub> = 5 mA		0.9		mV/°C

勝特力材料 886-3-5753170  
 勝特力电子(上海) 86-21-34970699  
 勝特力电子(深圳) 86-755-83298787  
[Http://www.100y.com.tw](http://www.100y.com.tw)

μPC29M12 (T<sub>J</sub> = 25°C, V<sub>IN</sub> = 15 V, I<sub>o</sub> = 350 mA, C<sub>IN</sub> = 0.22 μF, C<sub>OUT</sub> = 47 μF, unless otherwise specified.)

Parameters	Symbol	Conditions	MIN.	TYP.	MAX.	Unit
Output Voltage	V <sub>O</sub>		11.52	12	12.48	V
		0°C ≤ T <sub>J</sub> ≤ 125°C, 13 V ≤ V <sub>IN</sub> ≤ 18 V, 0 A ≤ I <sub>o</sub> ≤ 350 mA	11.4		12.6	
		0°C ≤ T <sub>J</sub> ≤ 125°C, 0 A ≤ I <sub>o</sub> ≤ 0.5 A				
Line Regulation	REG <sub>IN</sub>	13 V ≤ V <sub>IN</sub> ≤ 18 V		25	120	mV
Load Regulation	REG <sub>L</sub>	0 A ≤ I <sub>o</sub> ≤ 0.5 A		13	120	mV
Quiescent Current	I <sub>BIAS</sub>	I <sub>o</sub> = 0 A		2.1	4.0	mA
		I <sub>o</sub> = 0.5 A		14	30	
Startup Quiescent Current	I <sub>BIAS (s)</sub>	V <sub>IN</sub> = 11.5 V, I <sub>o</sub> = 0 A		10	30	mA
		V <sub>IN</sub> = 11.5 V, I <sub>o</sub> = 0.5 A			80	
Quiescent Current Change	ΔI <sub>BIAS</sub>	0°C ≤ T <sub>J</sub> ≤ 125°C, 13 V ≤ V <sub>IN</sub> ≤ 18 V		1.7	20	mA
Output Noise Voltage	V <sub>n</sub>	10 Hz ≤ f ≤ 100 kHz		210		μV <sub>r.m.s.</sub>
Ripple Rejection	R-R	f = 120 Hz, 13 V ≤ V <sub>IN</sub> ≤ 18 V	40	53		dB
Dropout Voltage	V <sub>DIF</sub>	0°C ≤ T <sub>J</sub> ≤ 125°C, I <sub>o</sub> = 0.5 A		0.5	1.0	V
Short Circuit Current	I <sub>O short</sub>	V <sub>IN</sub> = 14 V		0.7		A
		V <sub>IN</sub> = 18 V		0.5		
Peak Output Current	I <sub>o peak</sub>	V <sub>IN</sub> = 14 V	0.7	1.2	1.5	A
		V <sub>IN</sub> = 18 V	0.6	1.1	1.5	
Temperature Coefficient of Output Voltage	ΔV <sub>O</sub> /ΔT	0°C ≤ T <sub>J</sub> ≤ 125°C, I <sub>o</sub> = 5 mA		1.2		mV/°C

勝特力材料 886-3-5753170  
 勝特力电子(上海) 86-21-34970699  
 勝特力电子(深圳) 86-755-83298787  
[Http://www.100y.com.tw](http://www.100y.com.tw)

TYPICAL CHARACTERISTICS

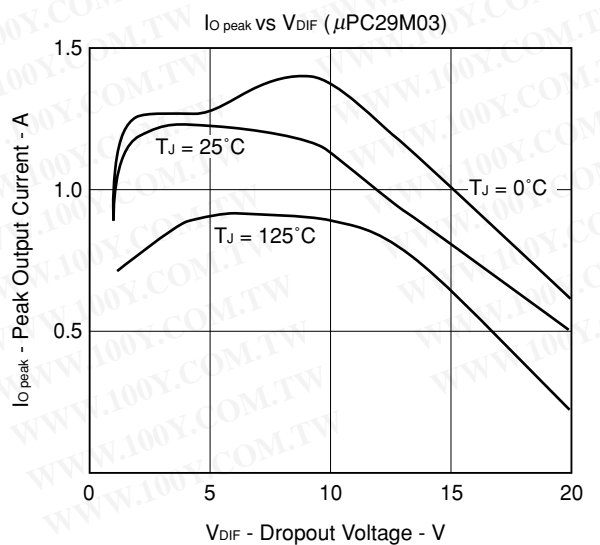
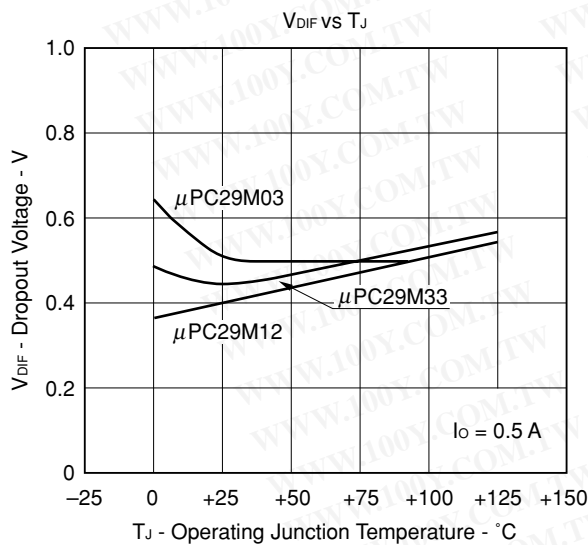
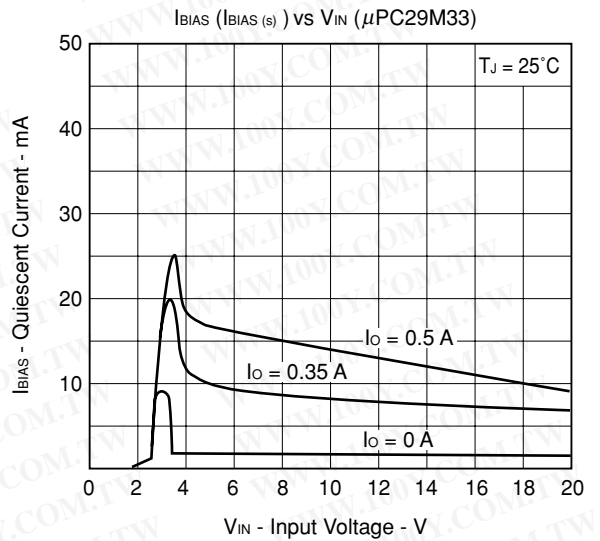
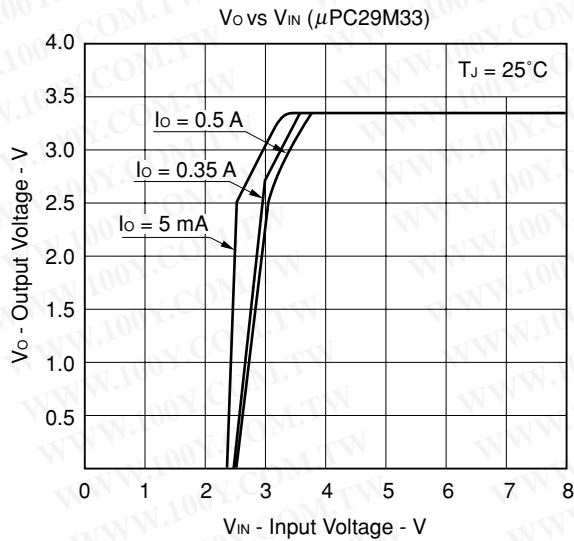
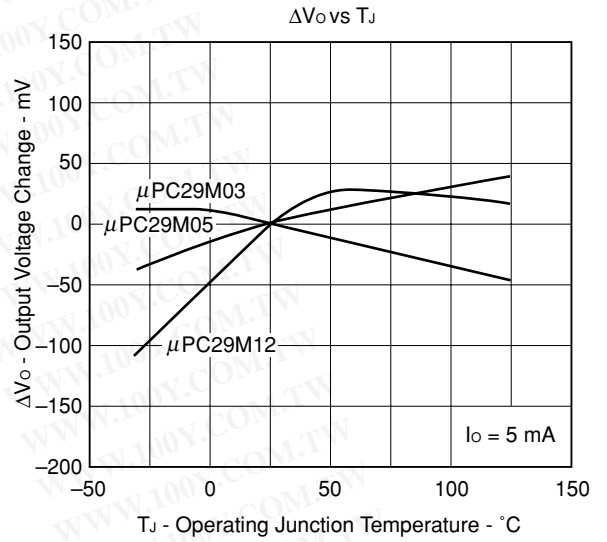
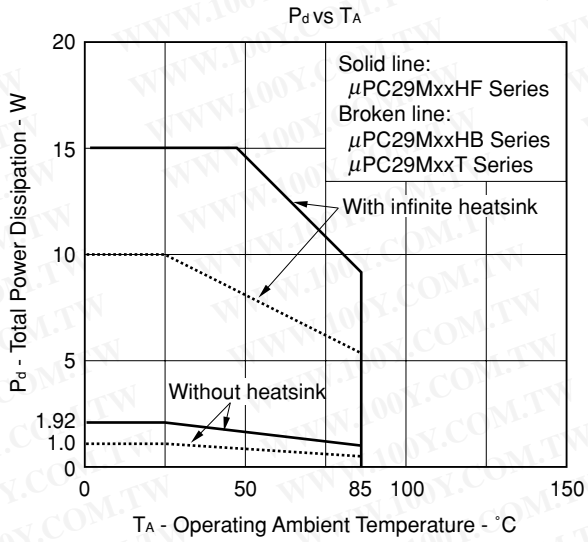

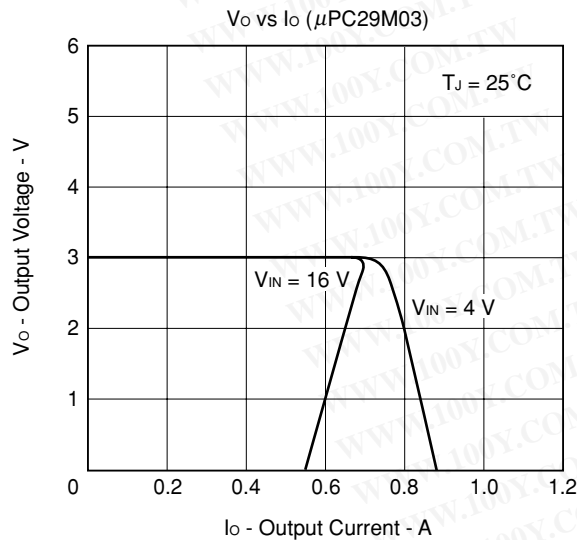
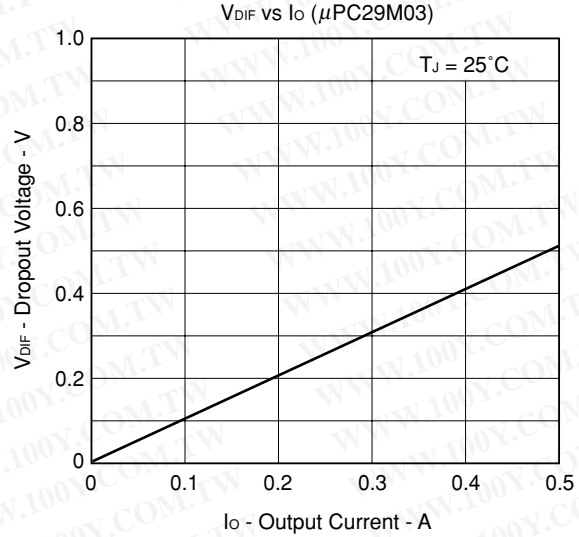
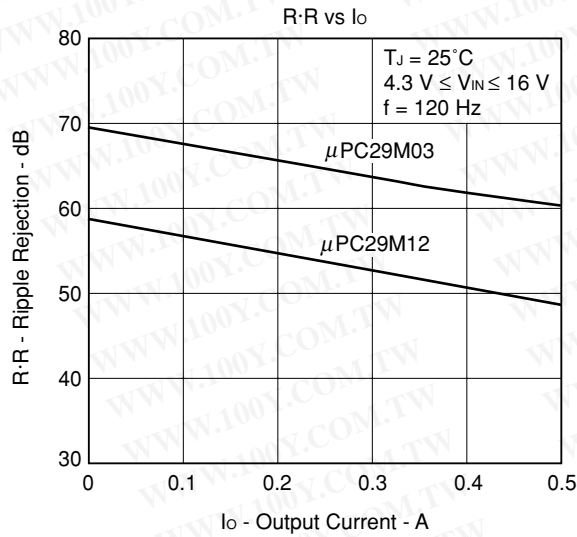
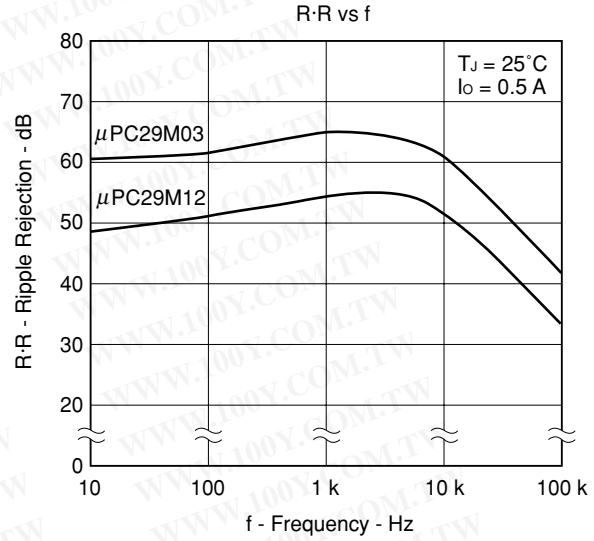
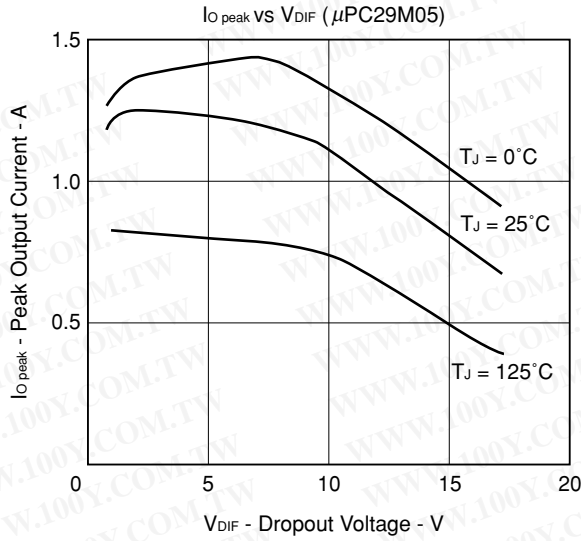

勝特力材料 886-3-5753170  
 勝特力电子(上海) 86-21-34970699  
 勝特力电子(深圳) 86-755-83298787  
[Http://www.100y.com.tw](http://www.100y.com.tw)



PACKAGE DRAWINGS

μPC29MxxHF Series

3PIN PLASTIC SIP (MP-45G)

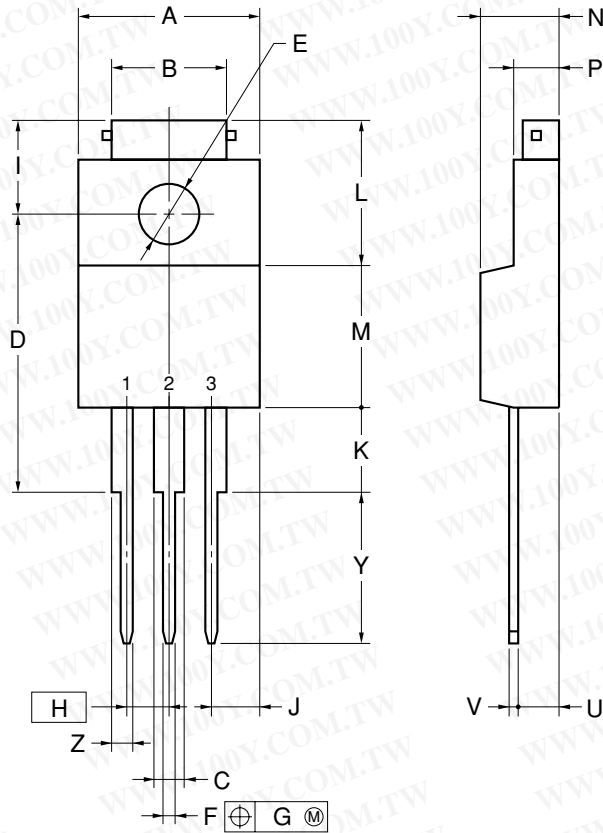

NOTE

Each lead centerline is located within 0.25 mm of its true position (T.P.) at maximum material condition.

ITEM	MILLIMETERS
A	10.0±0.2
B	7.0±0.2
C	1.50±0.2
D	17.0±0.3
E	φ3.3±0.2
F	0.75±0.10
G	0.25
H	2.54 (T.P.)
I	5.0±0.3
J	2.46±0.2
K	5.0±0.2
L	8.5±0.2
M	8.5±0.2
N	4.5±0.2
P	2.8±0.2
U	2.4±0.5
V	0.65±0.10
Y	8.9±0.7
Z	1.30±0.2

P3HF-254B-4

勝特力材料 886-3-5753170  
 勝特力电子(上海) 86-21-34970699  
 勝特力电子(深圳) 86-755-83298787  
[Http://www.100y.com.tw](http://www.100y.com.tw)

μPC29MxxHB Series

SC-64 (MP-3) (Unit: mm)

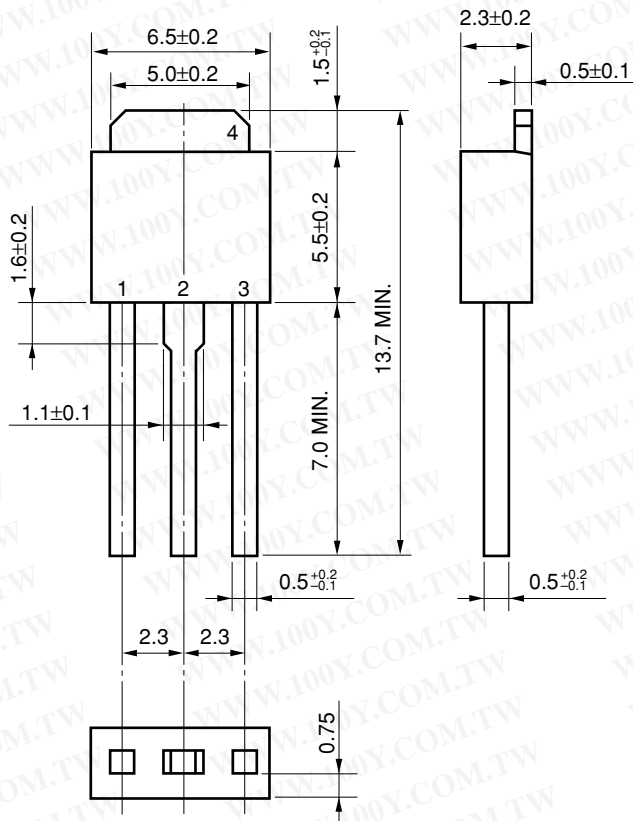

勝特力材料 886-3-5753170  
 勝特力电子(上海) 86-21-34970699  
 勝特力电子(深圳) 86-755-83298787  
[Http://www.100y.com.tw](http://www.100y.com.tw)

μPC29MxxT Series

<R> SC-63 (MP-3Z) (Unit: mm)

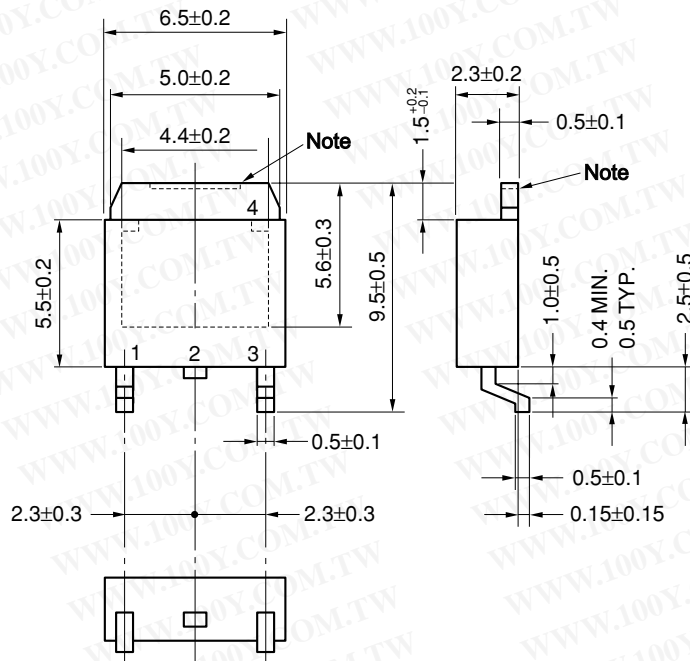

**Note** The depth of notch at the top of the fin is from 0 to 0.2 mm.

<R> **RECOMMENDED SOLDERING CONDITIONS**

When soldering this product, it is highly recommended to observe the conditions as shown below. If other soldering processes are used, or if the soldering is performed under different condition, please make sure to consult with our sales offices.

For more details, refer to the **Semiconductor Device Mount Manual**  
(<http://www.necel.com/pkg/en/mount/index.html>)

**Surface mount devices**

**μPC29MxxT Series: SC-63 (MP-3Z)**

Process	Conditions	Symbol
Infrared ray reflow	Peak temperature: 235°C or below (Package surface temperature), Reflow time: 30 seconds or less (at 210°C or higher), Maximum number of reflow processes: 3 times or less.	IR35-00-3
VPS	Peak temperature: 215°C or below (Package surface temperature), Reflow time: 40 seconds or less (at 200°C or higher), Maximum number of reflow processes: 3 times or less.	VP15-00-3
Partial heating method	Pin temperature: 350°C or below, Heat time: 3 seconds or less (Per each side of the device).	P350

**Caution** Apply only one kind of soldering condition to a device, except for “partial heating method”, or the device will be damaged by heat stress.

**Remark** Flux: Rosin-based flux sith low chlorine content (chlorine 0.2 Wt% or below) is recommended.

**μPC29MxxT-AZ Series <sup>Note1</sup>, μPC29MxxT-AY Series <sup>Note2</sup>: SC-63 (MP-3Z)**

Process	Conditions	Symbol
Infrared ray reflow	Peak temperature: 260°C or below (Package surface temperature), Reflow time: 60 seconds or less (at 220°C or higher), Maximum number of reflow processes: 3 times or less.	IR60-00-3
Partial heating method	Pin temperature: 350°C or below, Heat time: 3 seconds or less (Per each side of the device).	P350

**Notes 1.** Pb-free (This product does not contain Pb in the external electrode.)

**2.** Pb-free (This product does not contain Pb in the external electrode, Sn100% plating.)

**Caution** Apply only one kind of soldering condition to a device, except for “partial heating method”, or the device will be damaged by heat stress.

**Remark** Flux: Rosin-based flux sith low chlorine content (chlorine 0.2 Wt% or below) is recommended.

勝特力材料 886-3-5753170  
 勝特力电子(上海) 86-21-34970699  
 勝特力电子(深圳) 86-755-83298787  
[Http://www.100y.com.tw](http://www.100y.com.tw)

Through-hole devices

μPC29MxxHF Series, μPC29MxxHF-AZ Series <sup>Note1</sup>: Isolated TO-220 (MP-45G)

μPC29MxxHB Series, μPC29MxxHB-AZ Series <sup>Note1</sup>, μPC29MxxHB-AY Series <sup>Note2</sup>: SC-64 (MP-3)

Process	Conditions	Symbol
Wave soldering (only to leads)	Solder temperature: 260°C or below, Flow time: 10 seconds or less.	WS60-00-1
Partial heating method	Pin temperature: 350°C or below, Heat time: 3 seconds or less (Per each pin).	P350

**Notes 1.** Pb-free (This product does not contain Pb in the external electrode.)

**2.** Pb-free (This product does not contain Pb in the external electrode, Sn100% plating.)

**Caution** For through-hole device, the wave soldering process must be applied only to leads, and make sure that the package body does not get jet soldered.

**CAUTION ON USE**

When using the μPC29Mxx series at the input voltage which is lower than in the recommended operating condition, the high quiescent current flows through devices because the transistor of the output paragraph is saturated (Refer to “**I<sub>BIAS</sub> (I<sub>BIAS(s)</sub>) vs V<sub>IN</sub> curves in TYPICAL CHARACTERISTICS**”). The μPC29Mxx series have saturation protection circuits, but they sometimes need about 80 mA current. Therefore the power supply on the input needs the enough current capacity to pass this quiescent current when the devices startup.

<R> **REFERENCE DOCUMENTS**

USER'S MANUAL USAGE OF THREE TERMINAL REGULATORS Document No.G12702E  
 REVIEW OF QUALITY AND RELIABILITY HANDBOOK Document No.C12769E  
 INFORMATION VOLTAGE REGULATOR OF SMD Document No.G11872E  
 SEMICONDUCTOR DEVICE MOUNT MANUAL <http://www.necel.com/pkg/en/mount/index.html>

勝特力材料 886-3-5753170  
 勝特力电子(上海) 86-21-34970699  
 勝特力电子(深圳) 86-755-83298787  
[Http://www.100y.com.tw](http://www.100y.com.tw)