

## LM138/LM338

### 5-Amp Adjustable Regulators

#### General Description

The LM138 series of adjustable 3-terminal positive voltage regulators is capable of supplying in excess of 5A over a 1.2V to 32V output range. They are exceptionally easy to use and require only 2 resistors to set the output voltage. Careful circuit design has resulted in outstanding load and line regulation—comparable to many commercial power supplies. The LM138 family is supplied in a standard 3-lead transistor package.

A unique feature of the LM138 family is time-dependent current limiting. The current limit circuitry allows peak currents of up to 12A to be drawn from the regulator for short periods of time. This allows the LM138 to be used with heavy transient loads and speeds start-up under full-load conditions. Under sustained loading conditions, the current limit decreases to a safe value protecting the regulator. Also included on the chip are thermal overload protection and safe area protection for the power transistor. Overload protection remains functional even if the adjustment pin is accidentally disconnected.

Normally, no capacitors are needed unless the device is situated more than 6 inches from the input filter capacitors in which case an input bypass is needed. An output capacitor can be added to improve transient response, while bypassing the adjustment pin will increase the regulator's ripple rejection.

Besides replacing fixed regulators or discrete designs, the LM138 is useful in a wide variety of other applications. Since the regulator is "floating" and sees only the input-to-output differential voltage, supplies of several hundred volts can be regulated as long as the maximum input to output differential is not exceeded, i.e., do not short-circuit output to ground. The part numbers in the LM138 series which have a K suffix are packaged in a standard Steel TO-3 package, while those with a T suffix are packaged in a TO-220 plastic package. The LM138 is rated for  $-55^{\circ}\text{C} \leq T_J \leq +150^{\circ}\text{C}$ , and the LM338 is rated for  $0^{\circ}\text{C} \leq T_J \leq +125^{\circ}\text{C}$ .

#### Features

- Guaranteed 7A peak output current
- Guaranteed 5A output current
- Adjustable output down to 1.2V
- Guaranteed thermal regulation
- Current limit constant with temperature
- P+ Product Enhancement tested
- Output is short-circuit protected

#### Applications

- Adjustable power supplies
- Constant current regulators
- Battery chargers

#### Connection Diagrams (See Physical Dimension section for further information)

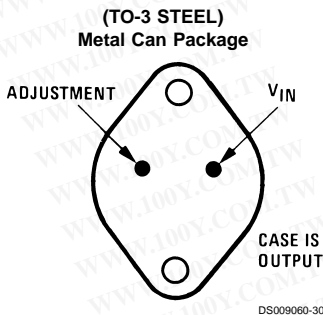

**Bottom View**  
Order Number LM138K STEEL or LM338K STEEL  
See NS Package Number K02A

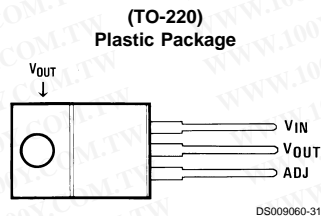

**Front View**  
Order Number LM338T  
See NS Package Number T03B

**勝特力材料 886-3-5753170**  
**勝特力电子(上海) 86-21-34970699**  
**勝特力电子(深圳) 86-755-83298787**  
[Http://www.100y.com.tw](http://www.100y.com.tw)

## Absolute Maximum Ratings (Note 1)

If Military/Aerospace specified devices are required, please contact the National Semiconductor Sales Office/Distributors for availability and specifications.

(Note 4)

Power Dissipation	Internally limited
Input/Output Voltage Differential	+40V, -0.3V
Storage Temperature	-65°C to +150°C

Lead Temperature

Metal Package (Soldering, 10 seconds)  
Plastic Package (Soldering, 4 seconds)

300°C

260°C

ESD Tolerance

TBD

## Operating Temperature Range

LM138

-55°C ≤ T<sub>J</sub> ≤ +150°C

LM338

0°C ≤ T<sub>J</sub> ≤ +125°C

## Electrical Characteristics

Specifications with standard type face are for T<sub>J</sub> = 25°C, and those with **boldface type** apply over full Operating Temperature Range. Unless otherwise specified, V<sub>IN</sub> - V<sub>OUT</sub> = 5V; and I<sub>OUT</sub> = 10 mA. (Note 2)

Symbol	Parameter	Conditions	LM138			Units
			Min	Typ	Max	
V <sub>REF</sub>	Reference Voltage	3V ≤ (V <sub>IN</sub> - V <sub>OUT</sub> ) ≤ 35V, 10 mA ≤ I <sub>OUT</sub> ≤ 5A, P ≤ 50W	<b>1.19</b>	<b>1.24</b>	<b>1.29</b>	V
V <sub>RLINE</sub>	Line Regulation	3V ≤ (V <sub>IN</sub> - V <sub>OUT</sub> ) ≤ 35V (Note 3)		0.005	0.01	%/V
V <sub>RLOAD</sub>	Load Regulation	10 mA ≤ I <sub>OUT</sub> ≤ 5A (Note 3)		0.1	0.3	%
				<b>0.3</b>	<b>0.6</b>	%
	Thermal Regulation	20 ms Pulse		0.002	0.01	%/W
I <sub>ADJ</sub>	Adjustment Pin Current			<b>45</b>	<b>100</b>	μA
ΔI <sub>ADJ</sub>	Adjustment Pin Current Change	10 mA ≤ I <sub>OUT</sub> ≤ 5A, 3V ≤ (V <sub>IN</sub> - V <sub>OUT</sub> ) ≤ 35V		<b>0.2</b>	<b>5</b>	μA
ΔV <sub>R/T</sub>	Temperature Stability	T <sub>MIN</sub> ≤ T <sub>J</sub> ≤ T <sub>MAX</sub>		<b>1</b>		%
I <sub>LOAD(Min)</sub>	Minimum Load Current	V <sub>IN</sub> - V <sub>OUT</sub> = 35V		<b>3.5</b>	<b>5</b>	mA
I <sub>CL</sub>	Current Limit	V <sub>IN</sub> - V <sub>OUT</sub> ≤ 10V DC 0.5 ms Peak	<b>5</b>	<b>8</b>		A
			<b>7</b>	<b>12</b>		A
		V <sub>IN</sub> - V <sub>OUT</sub> = 30V		1	1	A
V <sub>N</sub>	RMS Output Noise, % of V <sub>OUT</sub>	10 Hz ≤ f ≤ 10 kHz		0.003		%
$\frac{\Delta V_R}{\Delta V_{IN}}$	Ripple Rejection Ratio	V <sub>OUT</sub> = 10V, f = 120 Hz, C <sub>ADJ</sub> = 0 μF		<b>60</b>		dB
		V <sub>OUT</sub> = 10V, f = 120 Hz, C <sub>ADJ</sub> = 10 μF	<b>60</b>	<b>75</b>		dB
	Long-Term Stability	T <sub>J</sub> = 125°C, 1000 Hrs		0.3	1	%
θ <sub>JC</sub>	Thermal Resistance, Junction to Case	K Package			1	°C/W
θ <sub>JA</sub>	Thermal Resistance, Junction to Ambient (No Heat Sink)	K Package		35		°C/W

## Electrical Characteristics

Symbol	Parameter	Conditions	LM338			Units
			Min	Typ	Max	
V <sub>REF</sub>	Reference Voltage	3V ≤ (V <sub>IN</sub> - V <sub>OUT</sub> ) ≤ 35V, 10 mA ≤ I <sub>OUT</sub> ≤ 5A, P ≤ 50W	<b>1.19</b>	<b>1.24</b>	<b>1.29</b>	V
V <sub>RLINE</sub>	Line Regulation	3V ≤ (V <sub>IN</sub> - V <sub>OUT</sub> ) ≤ 35V (Note 3)		0.005	0.03	%/V
V <sub>RLOAD</sub>	Load Regulation	10 mA ≤ I <sub>OUT</sub> ≤ 5A (Note 3)		0.1	0.5	%
				<b>0.3</b>	<b>1</b>	%
	Thermal Regulation	20 ms Pulse		0.002	0.02	%/W
I <sub>ADJ</sub>	Adjustment Pin Current			<b>45</b>	<b>100</b>	μA
ΔI <sub>ADJ</sub>	Adjustment Pin Current Change	10 mA ≤ I <sub>OUT</sub> ≤ 5A, 3V ≤ (V <sub>IN</sub> - V <sub>OUT</sub> ) ≤ 35V		<b>0.2</b>	<b>5</b>	μA

## Electrical Characteristics (Continued)

Symbol	Parameter	Conditions	LM338			Units
			Min	Typ	Max	
$\Delta V_{R/T}$	Temperature Stability	$T_{MIN} \leq T_J \leq T_{MAX}$		1		%
$I_{LOAD(Min)}$	Minimum Load Current	$V_{IN} - V_{OUT} = 35V$		3.5	10	mA
$I_{CL}$	Current Limit	$V_{IN} - V_{OUT} \leq 10V$				
		DC	5	8		A
		0.5 ms Peak	7	12		A
		$V_{IN} - V_{OUT} = 30V$			1	A
$V_N$	RMS Output Noise, % of $V_{OUT}$	10 Hz $\leq f \leq$ 10 kHz		0.003		%
$\frac{\Delta V_R}{\Delta V_{IN}}$	Ripple Rejection Ratio	$V_{OUT} = 10V, f = 120 \text{ Hz}, C_{ADJ} = 0 \mu F$		60		dB
		$V_{OUT} = 10V, f = 120 \text{ Hz}, C_{ADJ} = 10 \mu F$	60	75		dB
	Long-Term Stability	$T_J = 125^\circ C, 1000 \text{ hrs}$		0.3	1	%
$\theta_{JC}$	Thermal Resistance Junction to Case	K Package			1	$^\circ C/W$
		T Package			4	$^\circ C/W$
$\theta_{JA}$	Thermal Resistance, Junction to Ambient (No Heat Sink)	K Package		35		$^\circ C/W$
		T Package		50		$^\circ C/W$

**Note 1:** Absolute Maximum Ratings indicate limits beyond which damage to the device may occur. Operating Ratings indicate conditions for which the device is intended to be functional, but do not guarantee specific performance limits. For guaranteed specifications and test conditions, see the Electrical Characteristics.

**Note 2:** These specifications are applicable for power dissipations up to 50W for the TO-3 (K) package and 25W for the TO-220 (T) package. Power dissipation is guaranteed at these values up to 15V input-output differential. Above 15V differential, power dissipation will be limited by internal protection circuitry. All limits (i.e., the numbers in the Min. and Max. columns) are guaranteed to National's AOQL (Average Outgoing Quality Level).

**Note 3:** Regulation is measured at a constant junction temperature, using pulse testing with a low duty cycle. Changes in output voltage due to heating effects are covered under the specifications for thermal regulation.

**Note 4:** Refer to RETS138K drawing for military specifications of LM138K.

## Typical Performance Characteristics

Current Limit

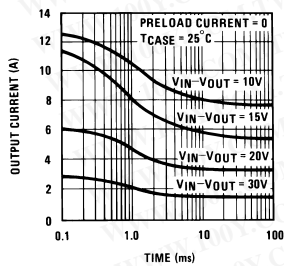

DS009060-32

Current Limit

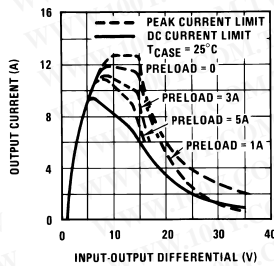

DS009060-33

Current Limit

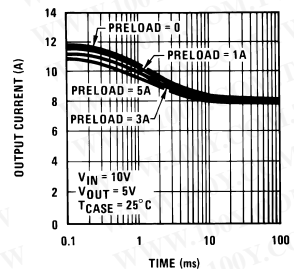

DS009060-34

Load Regulation

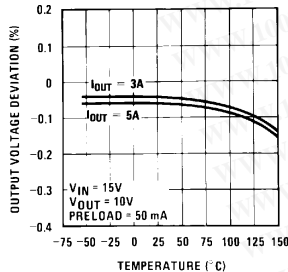

DS009060-35

Dropout Voltage

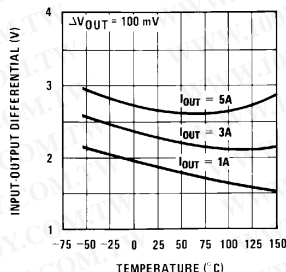

DS009060-36

Adjustment  
Current

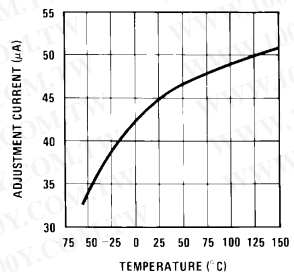

DS009060-37

## Typical Performance Characteristics (Continued)

### Temperature Stability

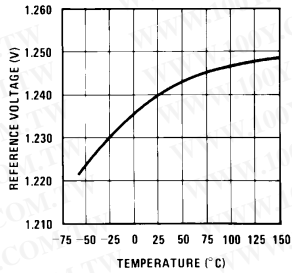

### Output Impedance

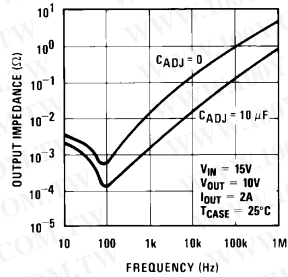

### Minimum Operating Current

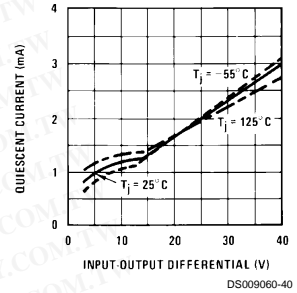

### Ripple Rejection

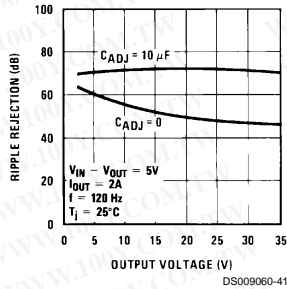

### Ripple Rejection

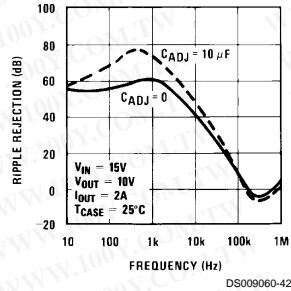

### Ripple Rejection

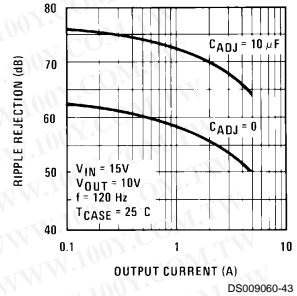

### Line Transient Response

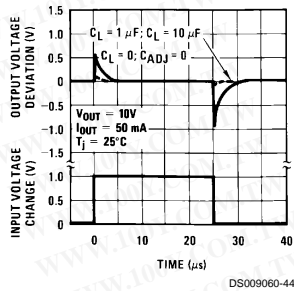

### Load Transient Response

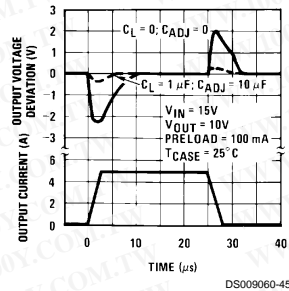

## Application Hints

In operation, the LM138 develops a nominal 1.25V reference voltage,  $V_{REF}$ , between the output and adjustment terminal. The reference voltage is impressed across program resistor R1 and, since the voltage is constant, a constant current  $I_1$  then flows through the output set resistor R2, giving an output voltage of

$$V_{OUT} = V_{REF} \left( 1 + \frac{R2}{R1} \right) + I_{ADJ}R2.$$

## Application Hints (Continued)

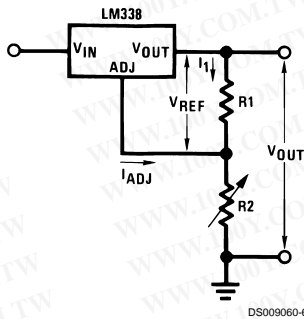

FIGURE 1.

Since the 50  $\mu\text{A}$  current from the adjustment terminal represents an error term, the LM138 was designed to minimize  $I_{\text{ADJ}}$  and make it very constant with line and load changes. To do this, all quiescent operating current is returned to the output establishing a minimum load current requirement. If there is insufficient load on the output, the output will rise.

### External Capacitors

An input bypass capacitor is recommended. A 0.1  $\mu\text{F}$  disc or 1  $\mu\text{F}$  solid tantalum on the input is suitable input bypassing for almost all applications. The device is more sensitive to the absence of input bypassing when adjustment or output capacitors are used but the above values will eliminate the possibility of problems.

The adjustment terminal can be bypassed to ground on the LM138 to improve ripple rejection. This bypass capacitor prevents ripple from being amplified as the output voltage is increased. With a 10  $\mu\text{F}$  bypass capacitor 75 dB ripple rejection is obtainable at any output level. Increases over 20  $\mu\text{F}$  do not appreciably improve the ripple rejection at frequencies above 120 Hz. If the bypass capacitor is used, it is sometimes necessary to include protection diodes to prevent the capacitor from discharging through internal low current paths and damaging the device.

In general, the best type of capacitors to use are solid tantalum. Solid tantalum capacitors have low impedance even at high frequencies. Depending upon capacitor construction, it takes about 25  $\mu\text{F}$  in aluminum electrolytic to equal 1  $\mu\text{F}$  solid tantalum at high frequencies. Ceramic capacitors are also good at high frequencies; but some types have a large decrease in capacitance at frequencies around 0.5 MHz. For this reason, 0.01  $\mu\text{F}$  disc may seem to work better than a 0.1  $\mu\text{F}$  disc as a bypass.

Although the LM138 is stable with no output capacitors, like any feedback circuit, certain values of external capacitance can cause excessive ringing. This occurs with values between 500 pF and 5000 pF. A 1  $\mu\text{F}$  solid tantalum (or 25  $\mu\text{F}$  aluminum electrolytic) on the output swamps this effect and insures stability.

### Load Regulation

The LM138 is capable of providing extremely good load regulation but a few precautions are needed to obtain maximum performance. The current set resistor connected between the adjustment terminal and the output terminal (usually 240 $\Omega$ ) should be tied directly to the output of the regulator (case) rather than near the load. This eliminates line drops from appearing effectively in series with the reference and degrading regulation. For example, a 15V regulator with 0.05 $\Omega$  resistance between the regulator and load will have a load regulation due to line resistance of  $0.05\Omega \times I_L$ . If the set resistor is connected near the load the effective line resistance will be  $0.05\Omega (1 + R2/R1)$  or in this case, 11.5 times worse.

Figure 2 shows the effect of resistance between the regulator and 240 $\Omega$  set resistor.

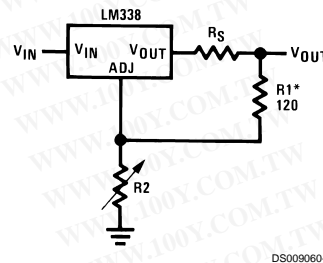

FIGURE 2. Regulator with Line Resistance in Output Lead

With the TO-3 package, it is easy to minimize the resistance from the case to the set resistor, by using 2 separate leads to the case. The ground of R2 can be returned near the ground of the load to provide remote ground sensing and improve load regulation.

### Protection Diodes

When external capacitors are used with *any* IC regulator it is sometimes necessary to add protection diodes to prevent the capacitors from discharging through low current points into the regulator. Most 20  $\mu\text{F}$  capacitors have low enough internal series resistance to deliver 20A spikes when shorted. Although the surge is short, there is enough energy to damage parts of the IC.

When an output capacitor is connected to a regulator and the input is shorted, the output capacitor will discharge into the output of the regulator. The discharge current depends on the value of the capacitor, the output voltage of the regulator, and the rate of decrease of  $V_{\text{IN}}$ . In the LM138 this discharge path is through a large junction that is able to sustain 25A surge with no problem. This is not true of other types of positive regulators. For output capacitors of 100  $\mu\text{F}$  or less at output of 15V or less, there is no need to use diodes.

The bypass capacitor on the adjustment terminal can discharge through a low current junction. Discharge occurs when *either* the input or output is shorted. Internal to the LM138 is a 50 $\Omega$  resistor which limits the peak discharge current. No protection is needed for output voltages of 25V or less and 10  $\mu\text{F}$  capacitance. Figure 3 shows an LM138 with protection diodes included for use with outputs greater than 25V and high values of output capacitance.

## Application Hints (Continued)

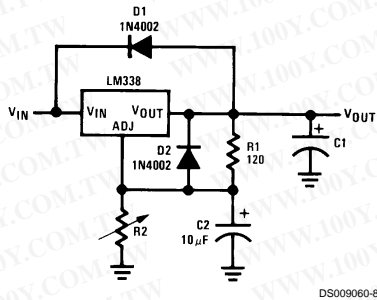

DS009060-8

D1 protects against C1  
D2 protects against C2

$$V_{OUT} = 1.25V \left( 1 + \frac{R_2}{R_1} \right) + I_{ADJ}R_2$$

FIGURE 3. Regulator with Protection Diodes

## Typical Applications

Regulator and Voltage Reference

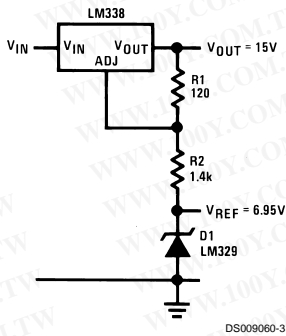

1.2V–25V Adjustable Regulator

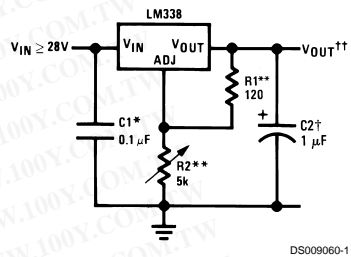

Temperature Controller

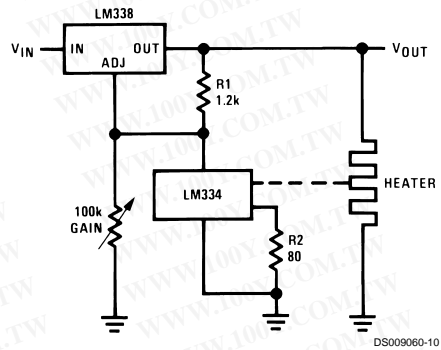

Full output current not available at high input-output voltages

†Optional—improves transient response. Output capacitors in the range of 1 μF to 1000 μF of aluminum or tantalum electrolytic are commonly used to provide improved output impedance and rejection of transients.

\*Needed if device is more than 6 inches from filter capacitors.

$$\dagger\dagger V_{OUT} = 1.25V \left( 1 + \frac{R_2}{R_1} \right) + I_{ADJ}(R_2)$$

\*\*R1 = 240Ω for LM138. R1, R2 as an assembly can be ordered from Bourns:

MIL part no. 7105A-AT2-502

COMM part no. 7105A-AT7-502

# Schematic Diagram

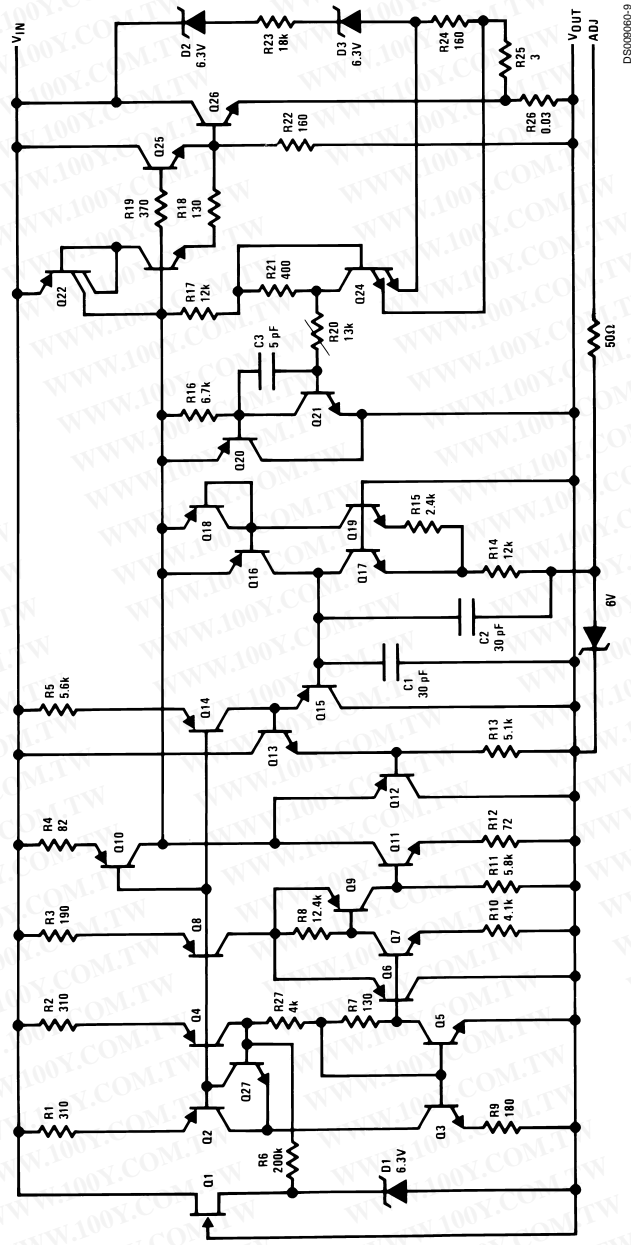



# Typical Applications

## Precision Power Regulator with Low Temperature Coefficient

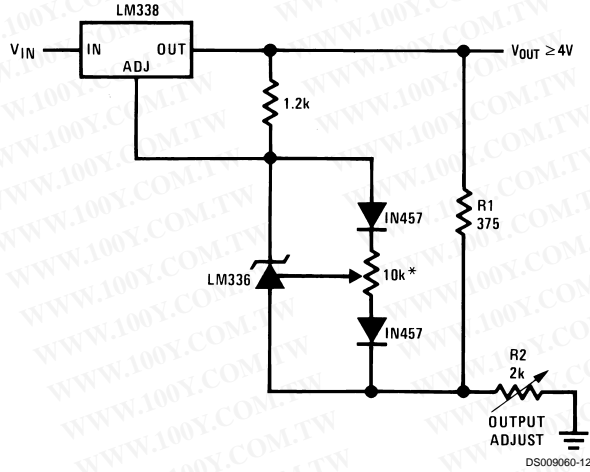

\* Adjust for 3.75 across R1

## Slow Turn-On 15V Regulator

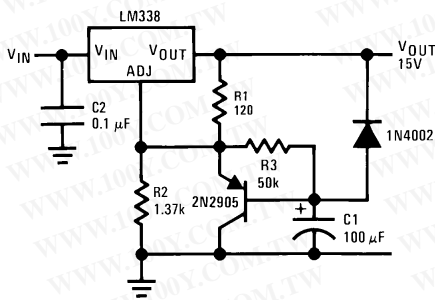

DS009060-13

## Adjustable Regulator with Improved Ripple Rejection

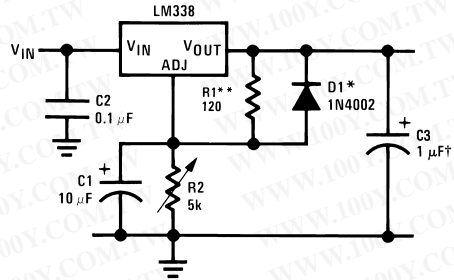

DS009060-14

†Solid tantalum

\*Discharges C1 if output is shorted to ground

\*\*R1 = 240Ω for LM138

## High Stability 10V Regulator

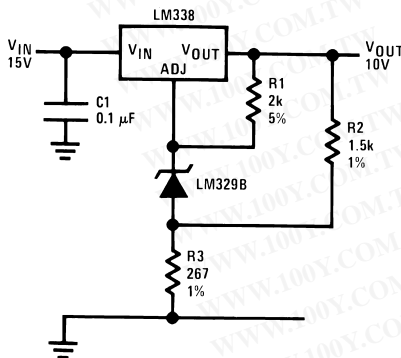

DS009060-15

## Digitally Selected Outputs

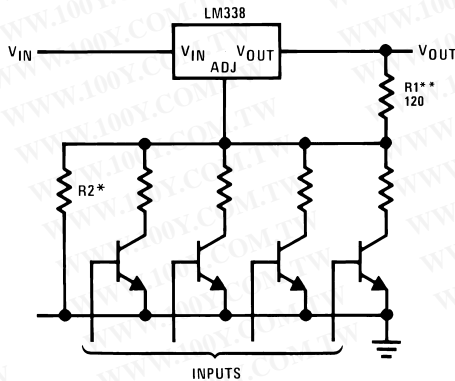

DS009060-16

\*Sets maximum  $V_{OUT}$

\*\*R1 = 240Ω for LM138

## Typical Applications (Continued)

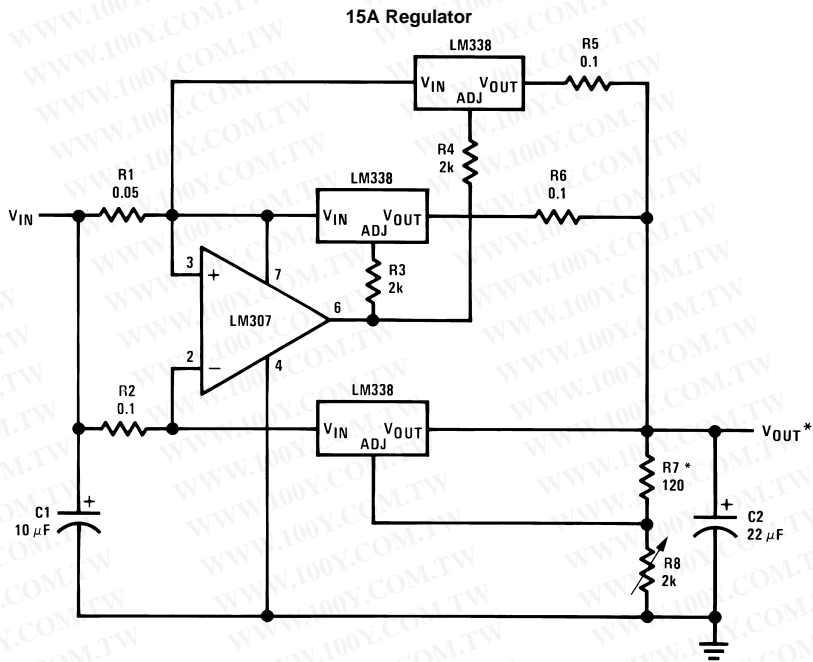

\* Minimum load — 100 mA

### 5V Logic Regulator with Electronic Shutdown\*\*

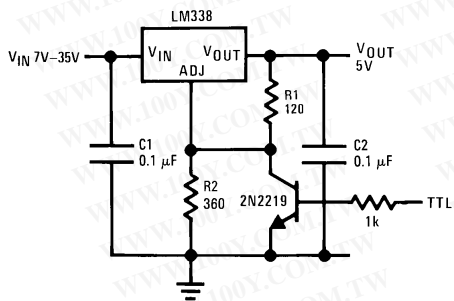

\*\* Minimum output  $\approx$  1.2V

### Light Controller

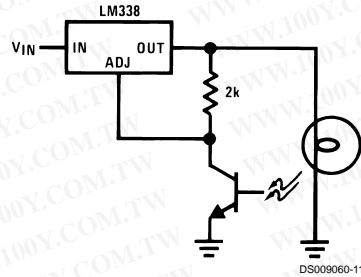

## Typical Applications (Continued)

### 0 to 22V Regulator

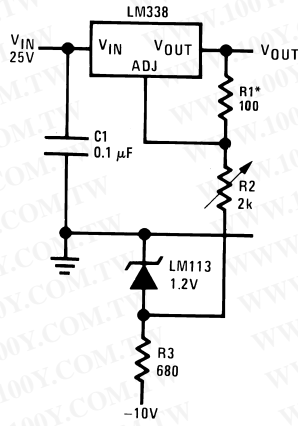

\* R1 = 240Ω, R2 = 5k for LM138  
Full output current not available  
at high input-output voltages

### 12V Battery Charger

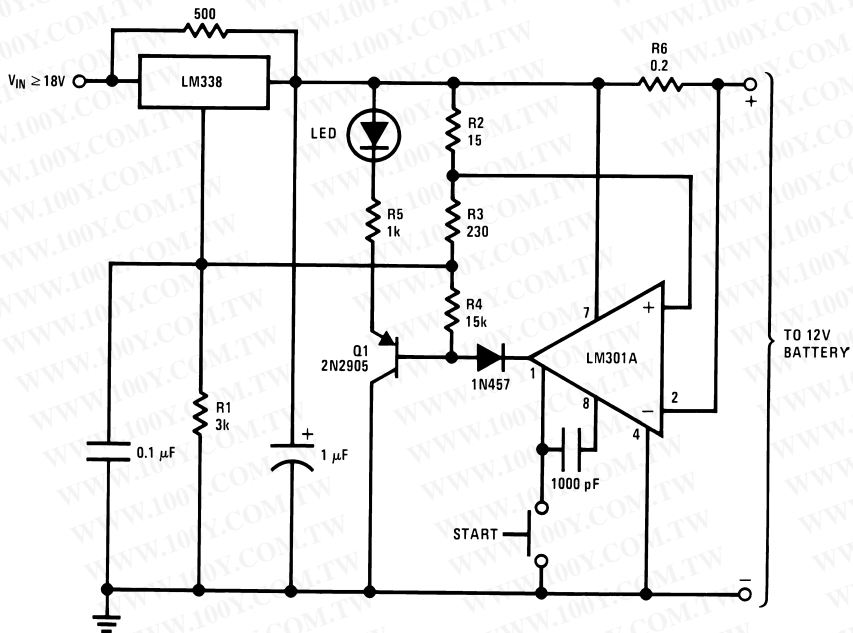

## Typical Applications (Continued)

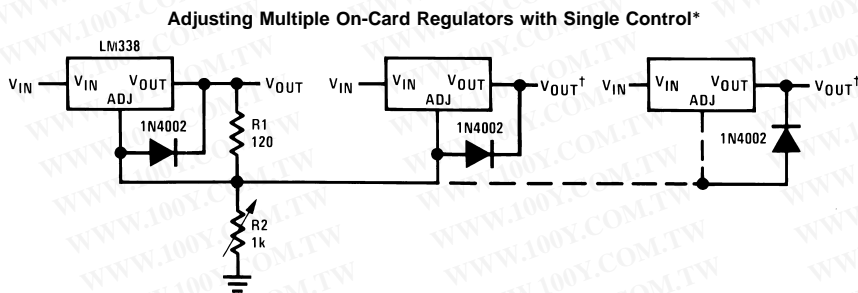
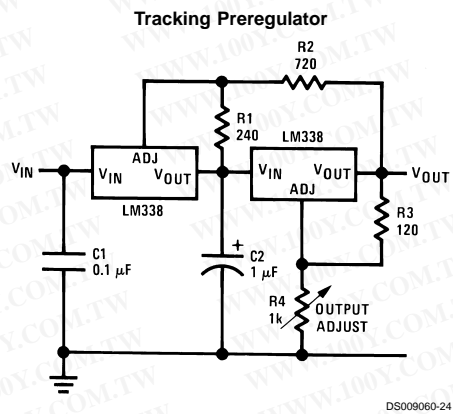
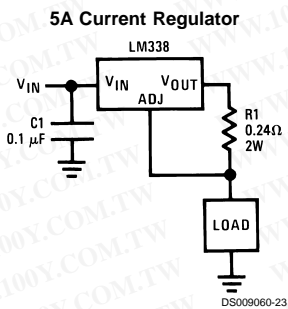
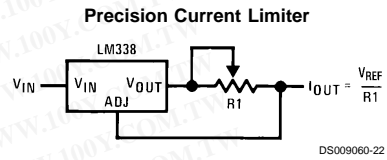
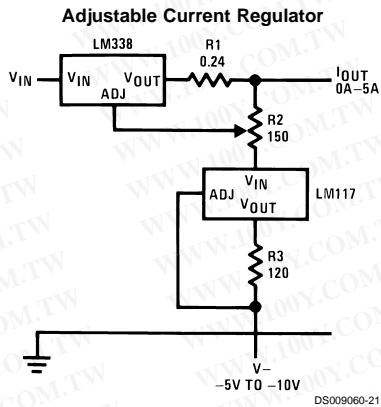

† Minimum load — 10 mA

\* All outputs within  $\pm 100$  mV

## Typical Applications (Continued)

### Power Amplifier

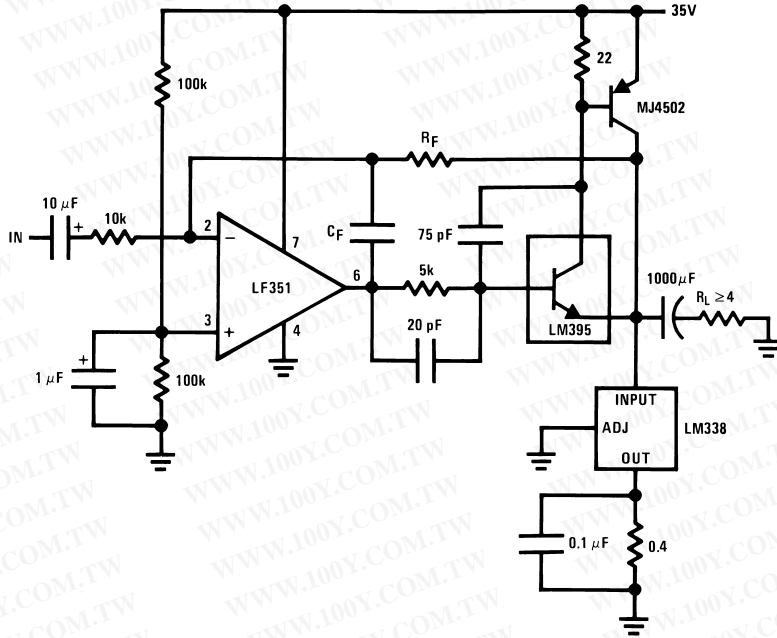

DS009060-27

$A_V = 1$ ,  $R_F = 10k$ ,  $C_F = 100\text{ pF}$   
 $A_V = 10$ ,  $R_F = 100k$ ,  $C_F = 10\text{ pF}$   
 Bandwidth  $\geq 100\text{ kHz}$   
 Distortion  $\leq 0.1\%$

### Simple 12V Battery Charger

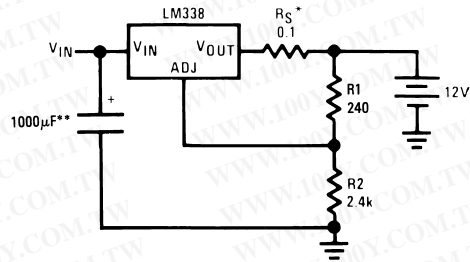

DS009060-28

\* $R_S$ —sets output impedance of charger  $Z_{OUT} = R_S \left( 1 + \frac{R_2}{R_1} \right)$

Use of  $R_S$  allows low charging rates with fully charged battery.

\*\*The 1000  $\mu\text{F}$  is recommended to filter out input transients

## Typical Applications (Continued)

### Adjustable 15A Regulator

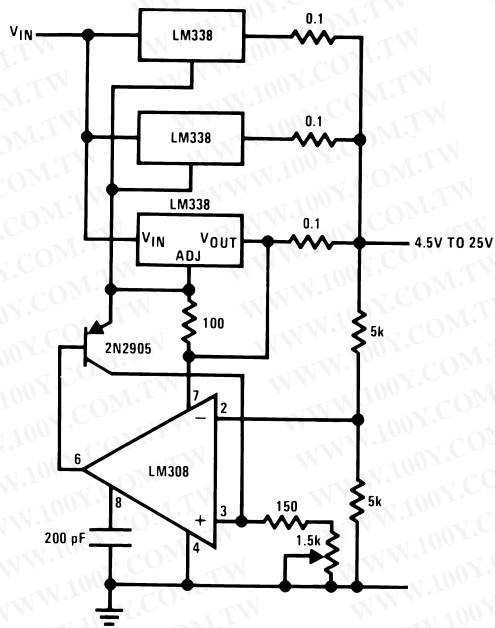

DS009060-26

### Current Limited 6V Charger

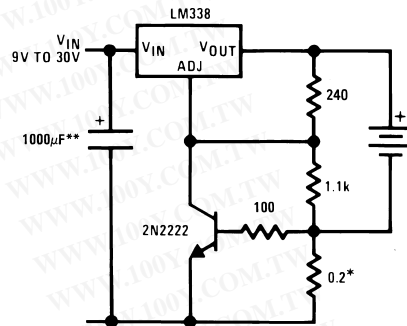

DS009060-29

\* Set max charge current to 3A

\*\* THE 1000 µF is recommended to filter out input transients.

### 10A Regulator

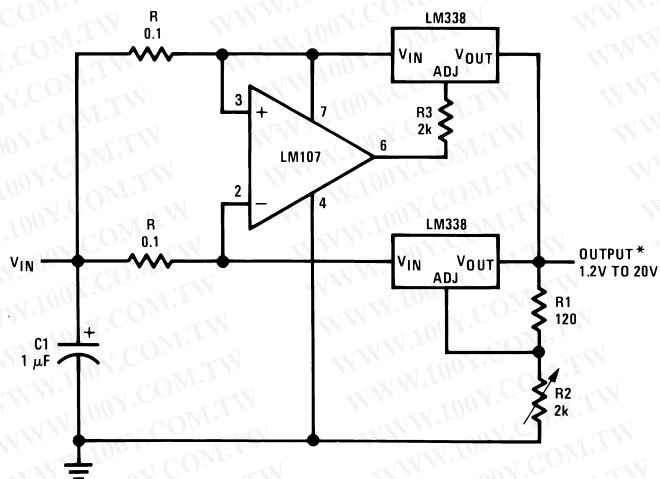

DS009060-2

\* Minimum load — 100 mA

**Physical Dimensions** inches (millimeters) unless otherwise noted

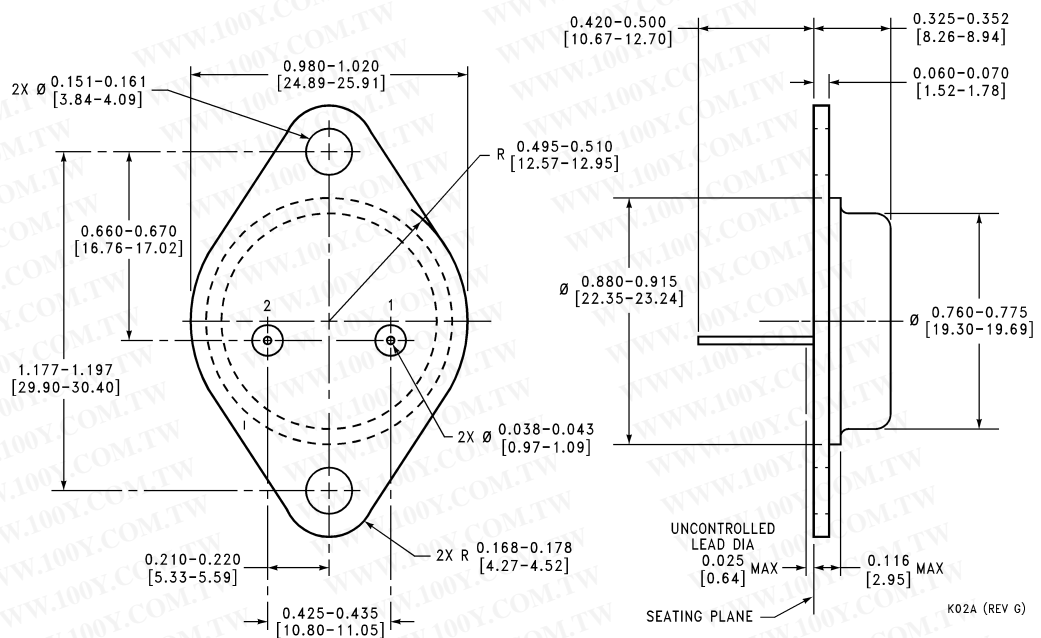

**2 Lead TO-3 Metal Can Package (K)**  
**Order Number LM138K or LM338K STEEL**  
**NS Package Number K02A**

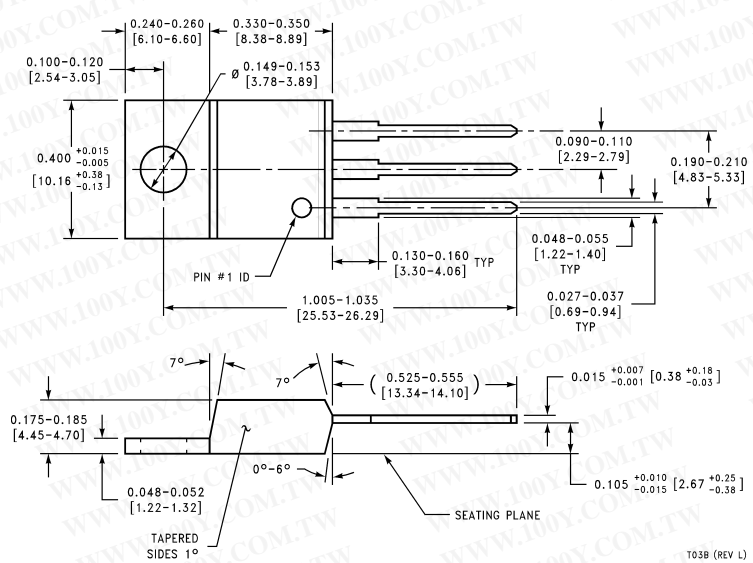

**3 Lead Molded TO-220 (T)**  
**Order Number LM338T**  
**NS Package Number T03B**

勝特力材料 886-3-5753170  
 勝特力电子(上海) 86-21-34970699  
 勝特力电子(深圳) 86-755-83298787  
[Http://www.100y.com.tw](http://www.100y.com.tw)