

## Current Mode PWM Controller

### FEATURES

- Automatic Feed Forward Compensation
- Programmable Pulse-by-Pulse Current Limiting
- Automatic Symmetry Correction in Push-pull Configuration
- Enhanced Load Response Characteristics
- Parallel Operation Capability for Modular Power Systems
- Differential Current Sense Amplifier with Wide Common Mode Range
- Double Pulse Suppression
- 500mA (Peak) Totem-pole Outputs
- $\pm 1\%$  Bandgap Reference
- Under-voltage Lockout
- Soft Start Capability
- Shutdown Terminal
- 500kHz Operation

### DESCRIPTION

The UC1846/7 family of control ICs provides all of the necessary features to implement fixed frequency, current mode control schemes while maintaining a minimum external parts count. The superior performance of this technique can be measured in improved line regulation, enhanced load response characteristics, and a simpler, easier-to-design control loop. Topological advantages include inherent pulse-by-pulse current limiting capability, automatic symmetry correction for push-pull converters, and the ability to parallel "power modules" while maintaining equal current sharing.

Protection circuitry includes built-in under-voltage lockout and programmable current limit in addition to soft start capability. A shutdown function is also available which can initiate either a complete shutdown with automatic restart or latch the supply off.

Other features include fully latched operation, double pulse suppression, deadline adjust capability, and a  $\pm 1\%$  trimmed bandgap reference.

The UC1846 features low outputs in the OFF state, while the UC1847 features high outputs in the OFF state.

### BLOCK DIAGRAM

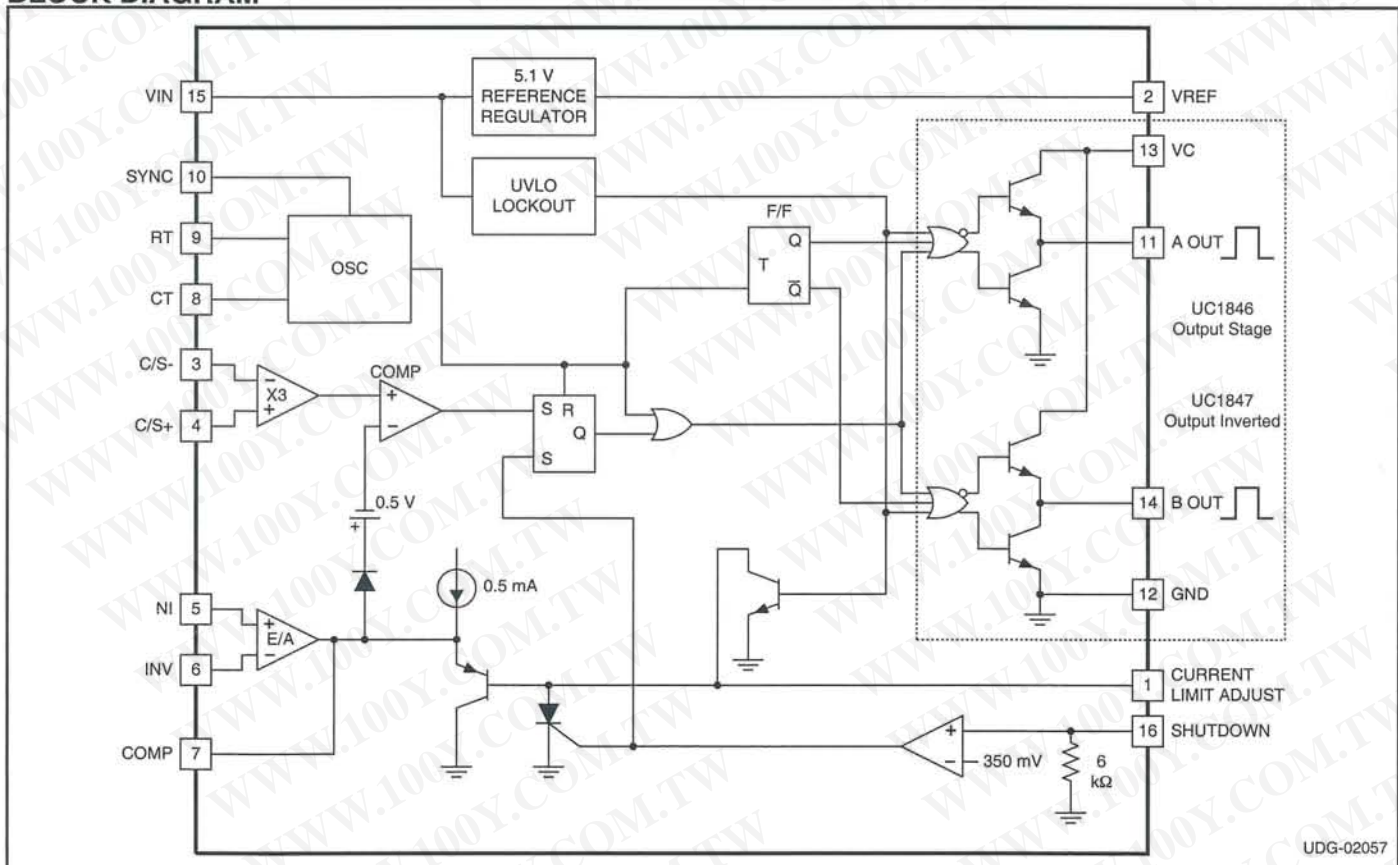

### ABSOLUTE MAXIMUM RATINGS (Note 1)

Supply Voltage (Pin 15)	+40V
Collector Supply Voltage (Pin 13)	+40V
Output Current, Source or Sink (Pins 11, 14)	500mA
Analog Inputs (Pins 3, 4, 5, 6, 16)	-0.3V to +V <sub>IN</sub>
Reference Output Current (Pin 2)	-30mA
Sync Output Current (Pin 10)	-5mA
Error Amplifier Output Current (Pin 7)	-5mA
Soft Start Sink Current (Pin 1)	50mA
Oscillator Charging Current (Pin 9)	5mA
Power Dissipation at T <sub>A</sub> =25°C	1000mW
Power Dissipation at T <sub>C</sub> =25°C	2000mW
Storage Temperature Range	-65°C to +150°C
Lead Temperature (soldering, 10 seconds)	+300°C

Note 1. All voltages are with respect to Ground, Pin 13. Currents are positive into, negative out of the specified terminal. Consult Packaging Section of Databook for thermal limitations and considerations of packages. Pin numbers refer to DIL and SOIC packages only.

### CONNECTION DIAGRAMS

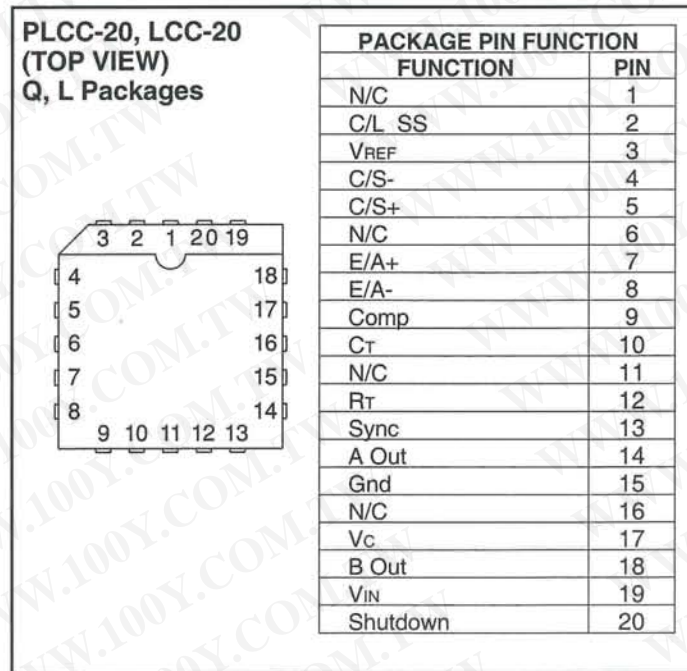
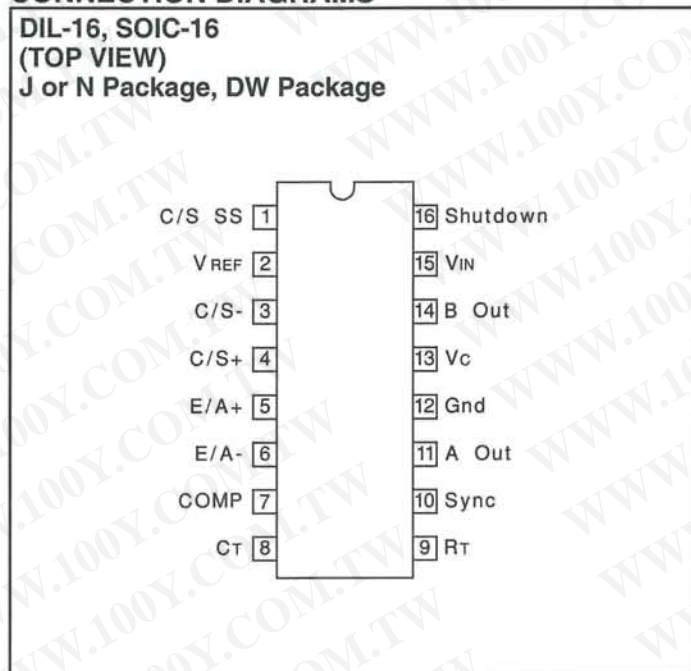

**ELECTRICAL CHARACTERISTICS** (Unless otherwise stated, these specifications apply for T<sub>A</sub>=-55°C to +125°C for UC1846/7; -40°C to +85°C for the UC2846/7; and 0°C to +70°C for the UC3846/7; V<sub>IN</sub>=15V, R<sub>T</sub>=10k, C<sub>T</sub>=4.7nF, T<sub>A</sub>=T<sub>J</sub>.)

PARAMETER	TEST CONDITIONS	UC1846/UC1847 UC2846/UC2847			UC3846/UC3847			UNITS
		MIN.	TYP.	MAX.	MIN.	TYP.	MAX.	
<b>Reference Section</b>								
Output Voltage	T <sub>J</sub> =25°C, I <sub>O</sub> =1mA	5.05	5.10	5.15	5.00	5.10	5.20	V
Line Regulation	V <sub>IN</sub> =8V to 40V		5	20		5	20	mV
Load Regulation	I <sub>L</sub> =1mA to 10mA		3	15		3	15	mV
Temperature Stability	Over Operating Range, (Note 2)		0.4			0.4		mV/°C
Total Output Variation	Line, Load, and Temperature (Note 2)	5.00		5.20	4.95		5.25	V
Output Noise Voltage	10Hz ≤ f ≤ 10kHz, T <sub>J</sub> =25°C (Note 2)		100			100		μV
Long Term Stability	T <sub>J</sub> =125°C, 1000 Hrs. (Note 2)		5			5		mV
Short Circuit Output Current	VREF=0V	-10	-45		-10	-45		mA

**ELECTRICAL CHARACTERISTICS (cont.)** (Unless otherwise stated, these specifications apply for  $T_A = -55^\circ\text{C}$  to  $+125^\circ\text{C}$  for UC1846/7;  $-40^\circ\text{C}$  to  $+85^\circ\text{C}$  for the UC2846/7; and  $0^\circ\text{C}$  to  $+70^\circ\text{C}$  for the UC3846/7;  $V_{IN} = 15\text{V}$ ,  $R_T = 10\text{k}$ ,  $C_T = 4.7\text{nF}$ ,  $T_A = T_J$ .)

PARAMETER	TEST CONDITIONS	UC1846/UC1847 UC2846/UC2847			UC3846/UC3847			UNITS
		MIN.	TYP.	MAX.	MIN.	TYP.	MAX.	
<b>Oscillator Section</b>								
Initial Accuracy	$T_J = 25^\circ\text{C}$	39	43	47	39	43	47	kHz
Voltage Stability	$V_{IN} = 8\text{V}$ to $40\text{V}$		-1	2		-1	2	%
Temperature Stability	Over Operating Range (Note 2)		-1			-1		%
Sync Output High Level		3.9	4.35		3.9	4.35		V
Sync Output Low Level			2.3	2.5		2.3	2.5	V
Sync Input High Level	Pin 8=0V	3.9			3.9			V
Sync Input Low Level	Pin 8=0V			2.5			2.5	V
Sync Input Current	Sync Voltage=3.9V, Pin 8=0V		1.3	1.5		1.3	1.5	mA
<b>Error Amp Section</b>								
Input Offset Voltage			0.5	5		0.5	10	mV
Input Bias Current			-0.6	-1		-0.6	-2	$\mu\text{A}$
Input Offset Current			40	250		40	250	nA
Common Mode Range	$V_{IN} = 8\text{V}$ to $40\text{V}$	0		$V_{IN} - 2\text{V}$	0		$V_{IN} - 2\text{V}$	V
Open Loop Voltage Gain	$\Delta V_O = 1.2$ to $3\text{V}$ , $V_{CM} = 2\text{V}$	80	105		80	105		dB
Unity Gain Bandwidth	$T_J = 25^\circ\text{C}$ (Note 2)	0.7	1.0		0.7	1.0		MHz
CMRR	$V_{CM} = 0\text{V}$ to $38\text{V}$ , $V_{IN} = 40\text{V}$	75	100		75	100		dB
PSRR	$V_{IN} = 8\text{V}$ to $40\text{V}$	80	105		80	105		dB
Output Sink Current	$V_{ID} = -15\text{mV}$ to $-5\text{V}$ , $V_{PIN 7} = 1.2\text{V}$	2	6		2	6		mA
Output Source Current	$V_{ID} = 15\text{mV}$ to $5\text{V}$ , $V_{PIN 7} = 2.5\text{V}$	-0.4	-0.5		-0.4	-0.5		mA
High Level Output Voltage	$R_L = (\text{Pin } 7) 15\text{k}\Omega$	4.3	4.6		4.3	4.6		V
Low Level Output Voltage			0.7	1		0.7	1	V
<b>Current Sense Amplifier Section</b>								
Amplifier Gain	$V_{PIN 3} = 0\text{V}$ , Pin 1 Open (Notes 3 & 4)	2.5	2.75	3.0	2.5	2.75	3.0	V
Maximum Differential Input Signal ( $V_{PIN 4} - V_{PIN 3}$ )	Pin 1 Open (Note 3) $R_L (\text{Pin } 7) = 15\text{k}\Omega$	1.1	1.2		1.1	1.2		V
Input Offset Voltage	$V_{PIN 1} = 0.5\text{V}$ , Pin 7 Open (Note 3)		5	25		5	25	mV
CMRR	$V_{CM} = 1\text{V}$ to $12\text{V}$	60	83		60	83		dB
PSRR	$V_{IN} = 8\text{V}$ to $40\text{V}$	60	84		60	84		dB
Input Bias Current	$V_{PIN 1} = 0.5\text{V}$ , Pin 7 Open (Note 3)		-2.5	-10		-2.5	-10	$\mu\text{A}$
Input Offset Current	$V_{PIN 1} = 0.5\text{V}$ , Pin 7 Open (Note 3)		0.08	1		0.08	1	$\mu\text{A}$
Input Common Mode Range		0		$V_{IN} - 3$	0		$V_{IN} - 3$	V
Delay to Outputs	$T_J = 25^\circ\text{C}$ , (Note 2)		200	500		200	500	ns
<b>Current Limit Adjust Section</b>								
Current Limit Offset	$V_{PIN 3} = 0\text{V}$ , $V_{PIN 4} = 0\text{V}$ , Pin 7 Open (Note 3)	0.45	0.5	0.55	0.45	0.5	0.55	V
Input Bias Current	$V_{PIN 5} = V_{REF}$ , $V_{PIN 6} = 0\text{V}$		-10	-30		-10	-30	$\mu\text{A}$
<b>Shutdown Terminal Section</b>								
Threshold Voltage		250	350	400	250	350	400	mV
Input Voltage Range		0		$V_{IN}$	0		$V_{IN}$	V
Minimum Latching Current (IPIN 1)	(Note 6)	3.0	1.5		3.0	1.5		mA

**ELECTRICAL CHARACTERISTICS (cont.)**

(Unless otherwise stated, these specifications apply for TA=-55°C to +125°C for UC1846/7; -40°C to +85°C for the UC2846/7; and 0°C to +70°C for the UC3846/7; VIN=15V, RT=10k, CT=4.7nF, TA=TJ.)

PARAMETER	TEST CONDITIONS	UC1846/UC1847 UC2846/UC2847			UC3846/UC3847			UNITS
		MIN.	TYP.	MAX.	MIN.	TYP.	MAX.	
<b>Shutdown Terminal Section (cont.)</b>								
Maximum Non-Latching Current (IPIN 1)	(Note 7)		1.5	0.8		1.5	0.8	mA
Delay to Outputs	TJ=25°C (Note 2)		300	600		300	600	ns
<b>Output Section</b>								
Collector-Emitter Voltage		40			40			V
Collector Leakage Current	VC=40V (Note 5)			200			200	µA
Output Low Level	ISINK=20mA		0.1	0.4		0.1	0.4	V
	ISINK=100mA		0.4	2.1		0.4	2.1	V
Output High Level	ISOURCE=20mA	13	13.5		13	13.5		V
	ISOURCE=100mA	12	13.5		12	13.5		V
Rise Time	CL=1nF, TJ=25°C (Note 2)		50	300		50	300	ns
Fall Time	CL=1nF, TJ=25°C (Note 2)		50	300		50	300	ns
<b>Under-Voltage Lockout Section</b>								
Start-Up Threshold			7.7	8.0		7.7	8.0	V
Threshold Hysteresis			0.75			0.75		V
<b>Total Standby Current</b>								
Supply Current			17	21		17	21	mA

Note 2. These parameters, although ensured over the recommended operating conditions, are not 100% tested in production.

Note 3. Parameter measured at trip point of latch with VPIN 5 = VREF, VPIN 6 = 0V.

Note 4. Amplifier gain defined as:  $G = \frac{\Delta V_{PIN7}}{\Delta V_{PIN4}}$ ;  $V_{PIN4} = 0$  to  $1.0V$

Note 5. Applies to UC1846/UC2846/UC3846 only due to polarity of outputs.

Note 6. Current into Pin 1 ensured to latch circuit in shutdown state.

Note 7. Current into Pin 1 ensured not to latch circuit in shutdown state.

**APPLICATIONS DATA**

**Oscillator Circuit**

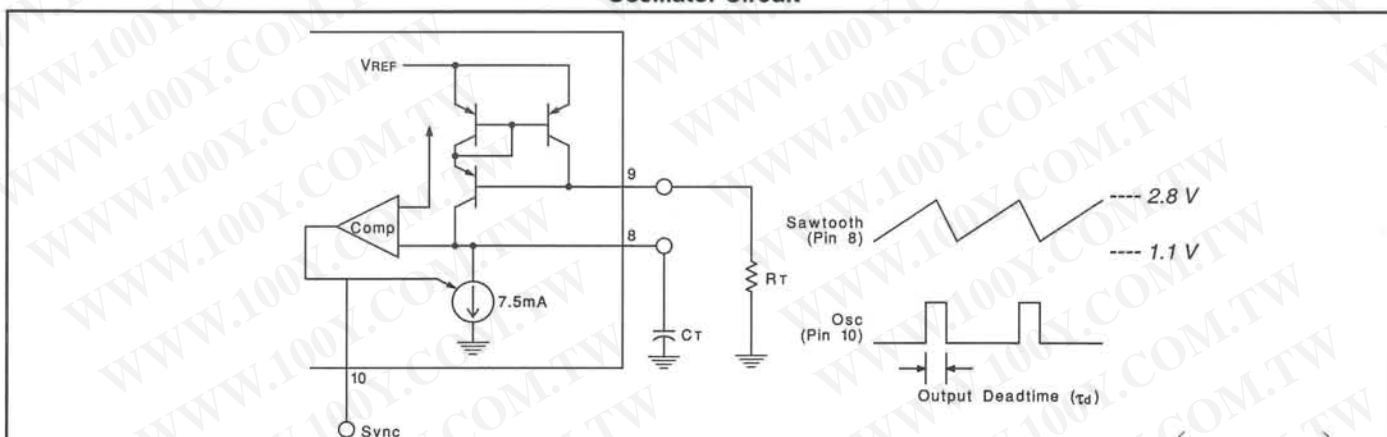

Output deadtime is determined by the external capacitor, CT, according to the formula:  $\tau_d (\mu s) = 145CT (\mu f) \left( \frac{I_D}{I_D - 3.6} \right)$

ID = Oscillator discharge current at 25°C is typically 7.5.

For large values of RT:  $\tau_d (\mu s) \approx 145CT (\mu f)$ .

Oscillator frequency is approximated by the formula:  $fT (kHz) \approx \frac{2.2}{RT (k\Omega) \cdot CT (\mu f)}$

APPLICATIONS DATA (cont.)

Error Amp Output Configuration

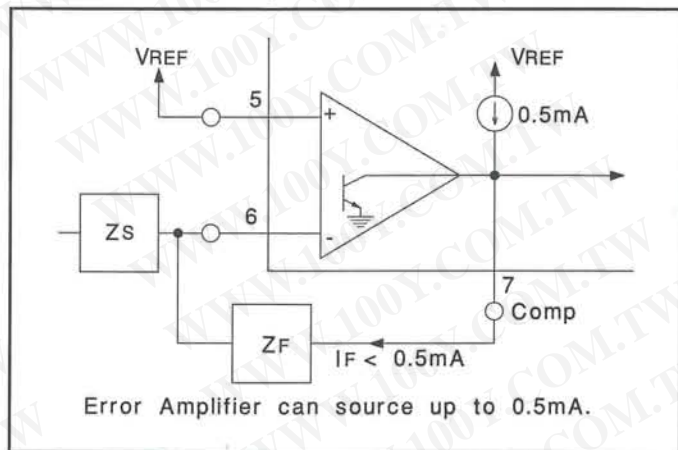

Error Amp Gain and Phase vs Frequency

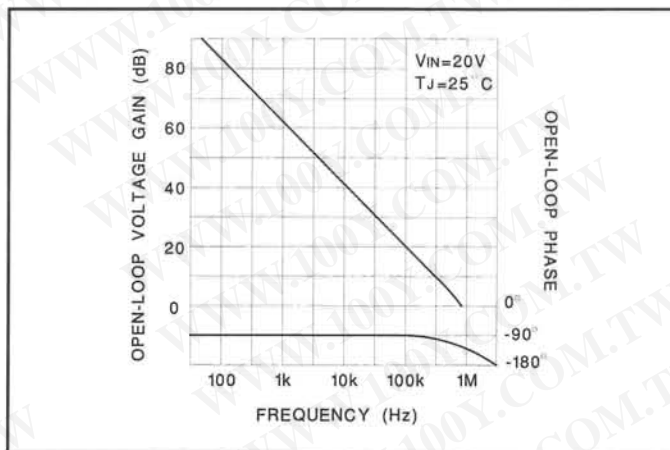

Error Amp Open-Logic D.C. Gain vs Load Resistance

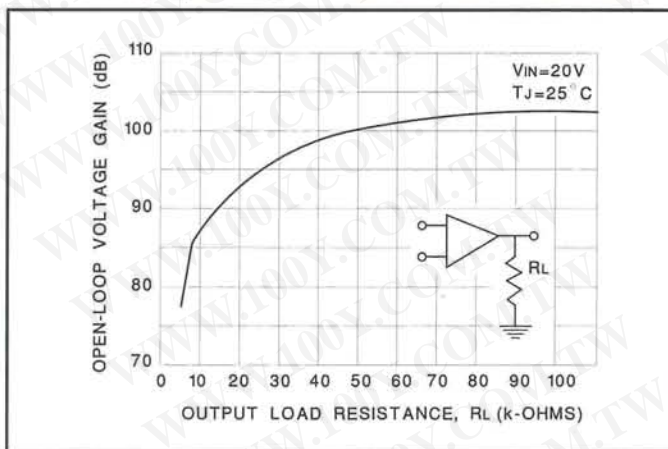

Parallel Operation

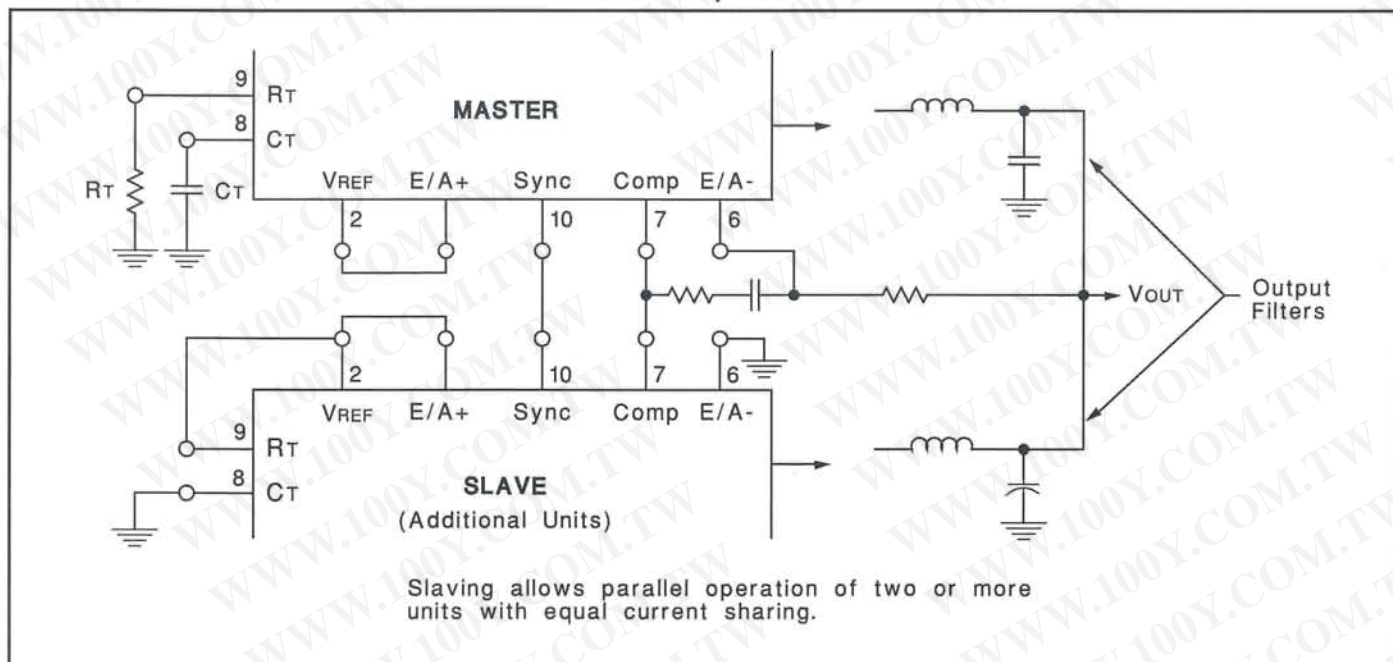

APPLICATIONS DATA (cont.)

Pulse by Pulse Current Limiting

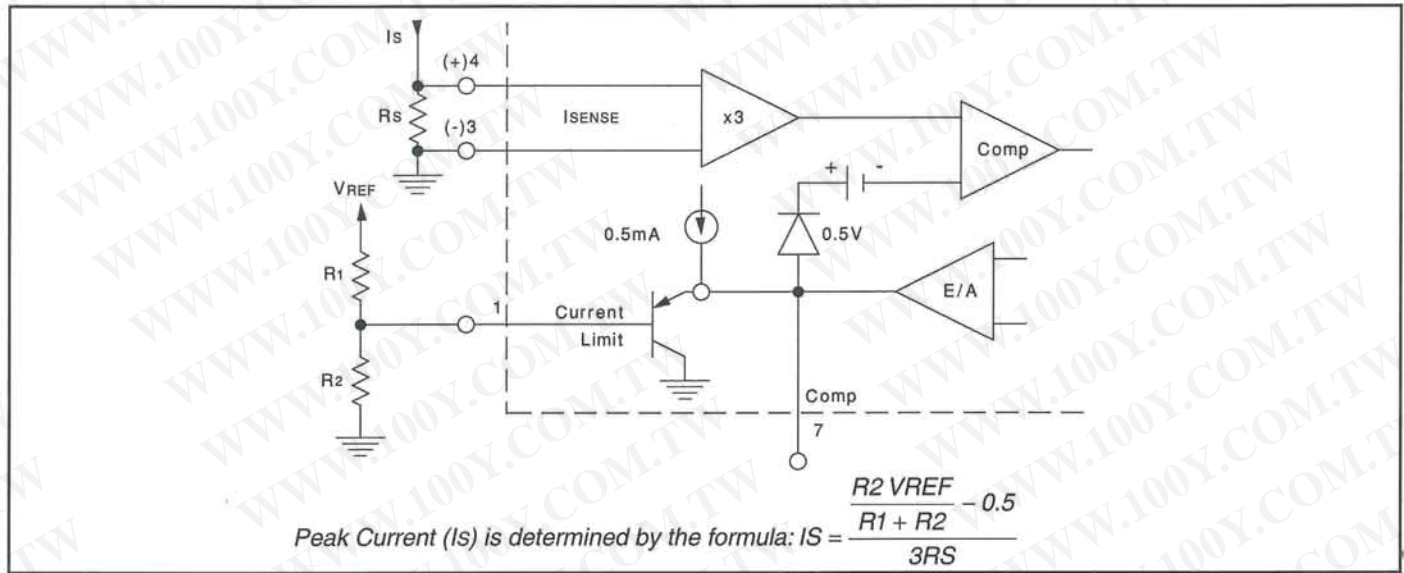

Soft Start and Shutdown /Restart Functions

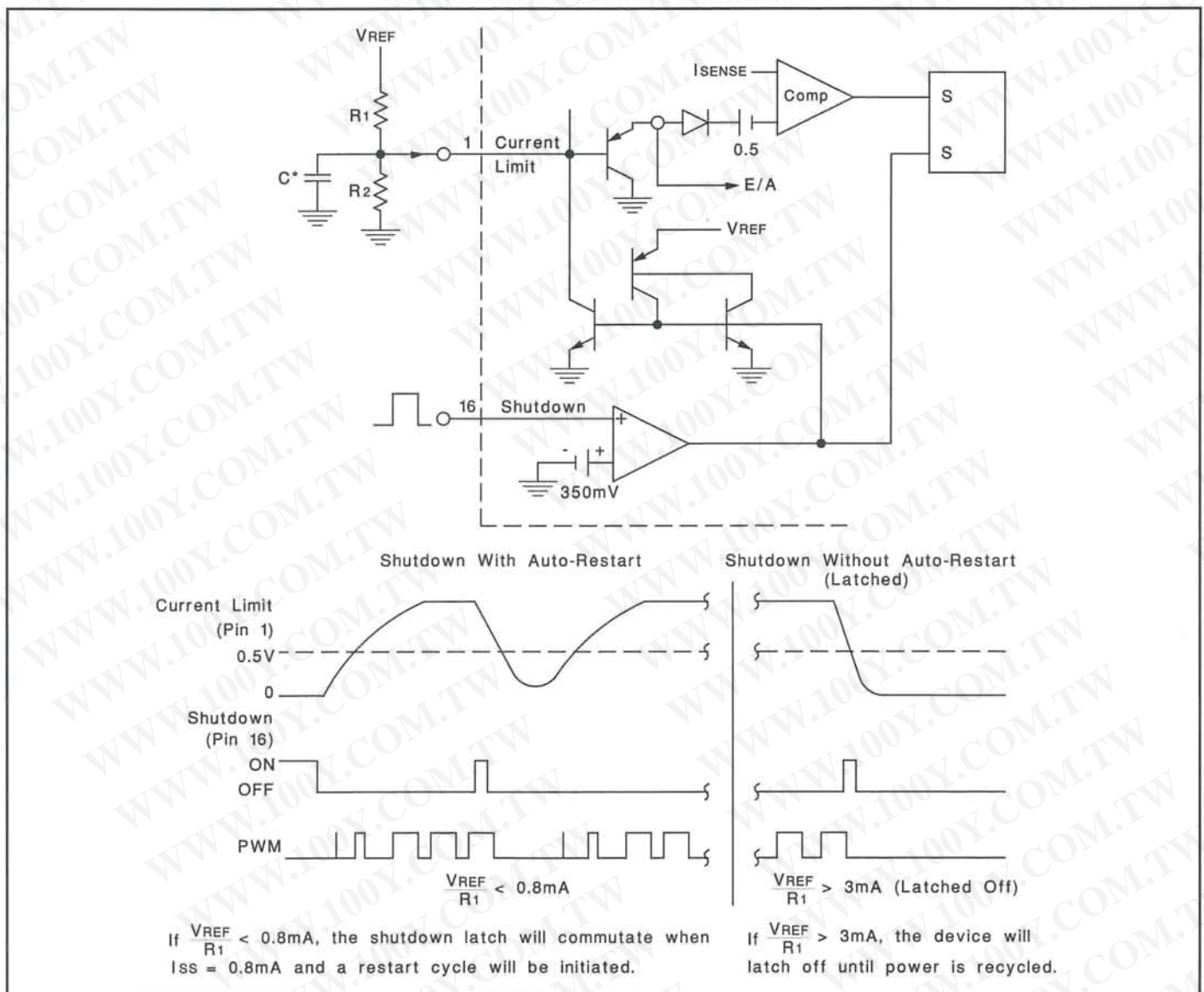

APPLICATIONS DATA (cont.)

Current Sense Amp Connection

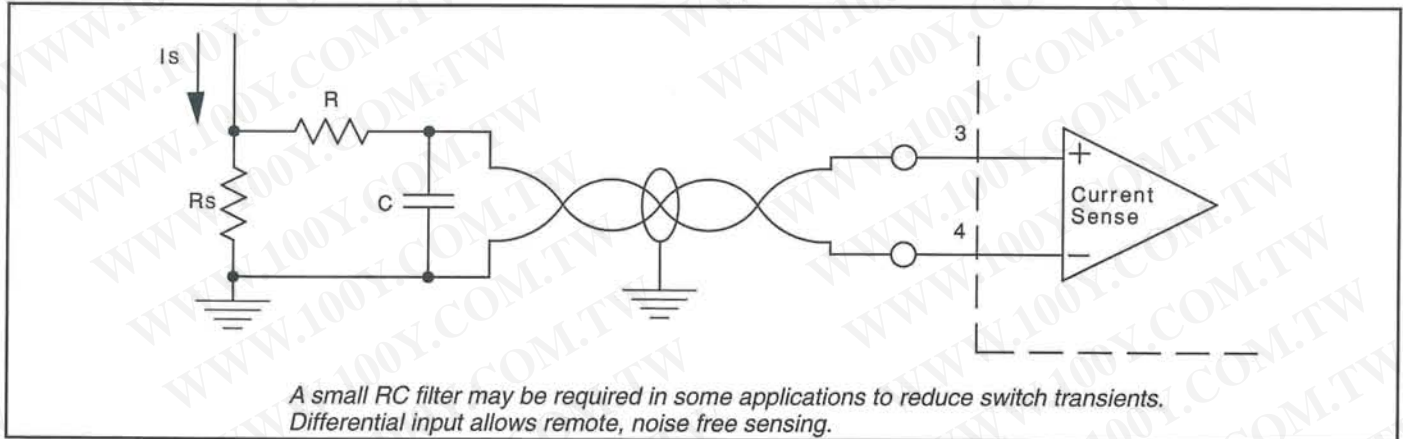

UC1846 Open Loop Test Circuit

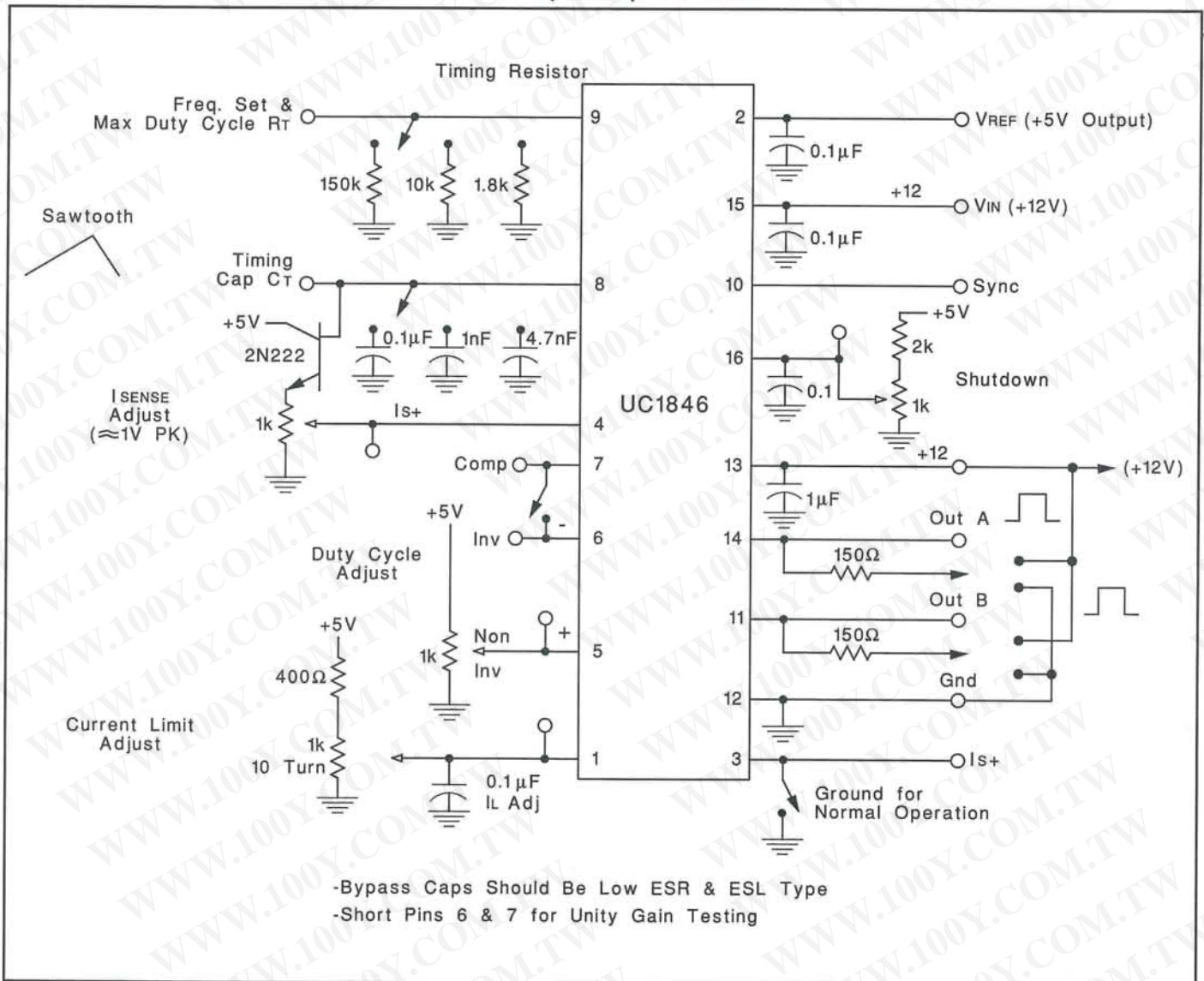

## REVISION HISTORY

SLUS352A to SLUS352B July 2010:

- 1) Updated block diagram, page 1.
- 2) Added peak and vally voltages to the Oscillator Circuit, page 4.



**PACKAGING INFORMATION**

Orderable Device	Status (1)	Package Type	Package Drawing	Pins	Package Qty	Eco Plan (2)	Lead/Ball Finish	MSL Peak Temp (3)	Op Temp (°C)	Device Marking (4/5)	Samples
5962-86806012A	ACTIVE	LCCC	FK	20	1	TBD	POST-PLATE	N / A for Pkg Type	-55 to 125	5962- 86806012A UC1846L/ 883B	<a href="#">Samples</a>
5962-8680601EA	ACTIVE	CDIP	J	16	1	TBD	A42	N / A for Pkg Type	-55 to 125	5962-8680601EA UC1846J/883B	<a href="#">Samples</a>
UC1846J	ACTIVE	CDIP	J	16	1	TBD	A42	N / A for Pkg Type	-55 to 125	UC1846J	<a href="#">Samples</a>
UC1846J/80257	OBSOLETE	CDIP	J	16		TBD	Call TI	Call TI	-55 to 125		
UC1846J/80364	OBSOLETE	CDIP	J	16		TBD	Call TI	Call TI	-55 to 125		
UC1846J/80619	OBSOLETE	CDIP	J	16		TBD	Call TI	Call TI	-55 to 125		
UC1846J883B	ACTIVE	CDIP	J	16	1	TBD	A42	N / A for Pkg Type	-55 to 125	5962-8680601EA UC1846J/883B	<a href="#">Samples</a>
UC1846L883B	ACTIVE	LCCC	FK	20	1	TBD	POST-PLATE	N / A for Pkg Type	-55 to 125	5962- 86806012A UC1846L/ 883B	<a href="#">Samples</a>
UC1847J	OBSOLETE	CDIP	J	16		TBD	Call TI	Call TI	-55 to 125		
UC1847J883B	OBSOLETE	CDIP	J	16		TBD	Call TI	Call TI	-55 to 125		
UC1847L	OBSOLETE	LCCC	FK	20		TBD	Call TI	Call TI	-55 to 125		
UC1847L883B	OBSOLETE	LCCC	FK	20		TBD	Call TI	Call TI	-55 to 125		
UC2846DW	ACTIVE	SOIC	DW	16	40	Green (RoHS & no Sb/Br)	CU NIPDAU	Level-2-260C-1 YEAR	-40 to 85	UC2846DW	<a href="#">Samples</a>
UC2846DWG4	ACTIVE	SOIC	DW	16	40	Green (RoHS & no Sb/Br)	CU NIPDAU	Level-2-260C-1 YEAR	-40 to 85	UC2846DW	<a href="#">Samples</a>
UC2846DWTR	ACTIVE	SOIC	DW	16	2000	Green (RoHS & no Sb/Br)	CU NIPDAU	Level-2-260C-1 YEAR	-40 to 85	UC2846DW	<a href="#">Samples</a>
UC2846DWTR/81265	OBSOLETE	SOIC	DW	16		TBD	Call TI	Call TI			
UC2846DWTR/81265G4	OBSOLETE	SOIC	DW	16		TBD	Call TI	Call TI			
UC2846DWTRG4	ACTIVE	SOIC	DW	16	2000	Green (RoHS & no Sb/Br)	CU NIPDAU	Level-2-260C-1 YEAR	-40 to 85	UC2846DW	<a href="#">Samples</a>
UC2846J	ACTIVE	CDIP	J	16	1	TBD	A42	N / A for Pkg Type	-40 to 85	UC2846J	<a href="#">Samples</a>

Orderable Device	Status (1)	Package Type	Package Drawing	Pins	Package Qty	Eco Plan (2)	Lead/Ball Finish	MSL Peak Temp (3)	Op Temp (°C)	Device Marking (4/5)	Samples
UC2846N	ACTIVE	PDIP	N	16	25	Green (RoHS & no Sb/Br)	CU NIPDAU	N / A for Pkg Type	-40 to 85	UC2846N	<a href="#">Samples</a>
UC2846NG4	ACTIVE	PDIP	N	16	25	Green (RoHS & no Sb/Br)	CU NIPDAU	N / A for Pkg Type	-40 to 85	UC2846N	<a href="#">Samples</a>
UC2846QTR	ACTIVE	PLCC	FN	20	1000	Green (RoHS & no Sb/Br)	CU SN	Level-2-260C-1 YEAR	-40 to 85	UC2846Q	<a href="#">Samples</a>
UC2846QTRG3	ACTIVE	PLCC	FN	20	1000	Green (RoHS & no Sb/Br)	CU SN	Level-2-260C-1 YEAR	-40 to 85	UC2846Q	<a href="#">Samples</a>
UC2847DW	ACTIVE	SOIC	DW	16	40	Green (RoHS & no Sb/Br)	CU NIPDAU	Level-2-260C-1 YEAR	-40 to 85	UC2847DW	<a href="#">Samples</a>
UC2847DWG4	ACTIVE	SOIC	DW	16	40	Green (RoHS & no Sb/Br)	CU NIPDAU	Level-2-260C-1 YEAR	-40 to 85	UC2847DW	<a href="#">Samples</a>
UC2847N	ACTIVE	PDIP	N	16	25	Green (RoHS & no Sb/Br)	CU NIPDAU	N / A for Pkg Type	-40 to 85	UC2847N	<a href="#">Samples</a>
UC2847NG4	ACTIVE	PDIP	N	16	25	Green (RoHS & no Sb/Br)	CU NIPDAU	N / A for Pkg Type	-40 to 85	UC2847N	<a href="#">Samples</a>
UC3846DW	ACTIVE	SOIC	DW	16	40	Green (RoHS & no Sb/Br)	CU NIPDAU	Level-2-260C-1 YEAR	0 to 70	UC3846DW	<a href="#">Samples</a>
UC3846DWG4	ACTIVE	SOIC	DW	16	40	Green (RoHS & no Sb/Br)	CU NIPDAU	Level-2-260C-1 YEAR	0 to 70	UC3846DW	<a href="#">Samples</a>
UC3846DWTR	ACTIVE	SOIC	DW	16	2000	Green (RoHS & no Sb/Br)	CU NIPDAU	Level-2-260C-1 YEAR	0 to 70	UC3846DW	<a href="#">Samples</a>
UC3846DWTRG4	ACTIVE	SOIC	DW	16	2000	Green (RoHS & no Sb/Br)	CU NIPDAU	Level-2-260C-1 YEAR	0 to 70	UC3846DW	<a href="#">Samples</a>
UC3846J	ACTIVE	CDIP	J	16	1	TBD	A42	N / A for Pkg Type	0 to 70	UC3846J	<a href="#">Samples</a>
UC3846N	ACTIVE	PDIP	N	16	25	Green (RoHS & no Sb/Br)	CU NIPDAU	N / A for Pkg Type	0 to 70	UC3846N	<a href="#">Samples</a>
UC3846NG4	ACTIVE	PDIP	N	16	25	Green (RoHS & no Sb/Br)	CU NIPDAU	N / A for Pkg Type	0 to 70	UC3846N	<a href="#">Samples</a>
UC3846Q	ACTIVE	PLCC	FN	20	46	Green (RoHS & no Sb/Br)	CU SN	Level-2-260C-1 YEAR	0 to 70	UC3846Q	<a href="#">Samples</a>
UC3846QG3	ACTIVE	PLCC	FN	20	46	Green (RoHS & no Sb/Br)	CU SN	Level-2-260C-1 YEAR	0 to 70	UC3846Q	<a href="#">Samples</a>
UC3846QTR	ACTIVE	PLCC	FN	20	1000	Green (RoHS & no Sb/Br)	CU SN	Level-2-260C-1 YEAR	0 to 70	UC3846Q	<a href="#">Samples</a>

Orderable Device	Status (1)	Package Type	Package Drawing	Pins	Package Qty	Eco Plan (2)	Lead/Ball Finish	MSL Peak Temp (3)	Op Temp (°C)	Device Marking (4/5)	Samples
UC3846QTRG3	ACTIVE	PLCC	FN	20	1000	Green (RoHS & no Sb/Br)	CU SN	Level-2-260C-1 YEAR	0 to 70	UC3846Q	<a href="#">Samples</a>
UC3847DW	ACTIVE	SOIC	DW	16	40	Green (RoHS & no Sb/Br)	CU NIPDAU	Level-2-260C-1 YEAR	0 to 70	UC3847DW	<a href="#">Samples</a>
UC3847DWG4	ACTIVE	SOIC	DW	16	40	Green (RoHS & no Sb/Br)	CU NIPDAU	Level-2-260C-1 YEAR	0 to 70	UC3847DW	<a href="#">Samples</a>
UC3847J	OBSOLETE	CDIP	J	16		TBD	Call TI	Call TI	0 to 70		
UC3847N	ACTIVE	PDIP	N	16	25	Green (RoHS & no Sb/Br)	CU NIPDAU	N / A for Pkg Type	0 to 70	UC3847N	<a href="#">Samples</a>
UC3847NG4	ACTIVE	PDIP	N	16	25	Green (RoHS & no Sb/Br)	CU NIPDAU	N / A for Pkg Type	0 to 70	UC3847N	<a href="#">Samples</a>

(1) The marketing status values are defined as follows:

**ACTIVE:** Product device recommended for new designs.

**LIFEBUY:** TI has announced that the device will be discontinued, and a lifetime-buy period is in effect.

**NRND:** Not recommended for new designs. Device is in production to support existing customers, but TI does not recommend using this part in a new design.

**PREVIEW:** Device has been announced but is not in production. Samples may or may not be available.

**OBSOLETE:** TI has discontinued the production of the device.

(2) Eco Plan - The planned eco-friendly classification: Pb-Free (RoHS), Pb-Free (RoHS Exempt), or Green (RoHS & no Sb/Br) - please check <http://www.ti.com/productcontent> for the latest availability information and additional product content details.

**TBD:** The Pb-Free/Green conversion plan has not been defined.

**Pb-Free (RoHS):** TI's terms "Lead-Free" or "Pb-Free" mean semiconductor products that are compatible with the current RoHS requirements for all 6 substances, including the requirement that lead not exceed 0.1% by weight in homogeneous materials. Where designed to be soldered at high temperatures, TI Pb-Free products are suitable for use in specified lead-free processes.

**Pb-Free (RoHS Exempt):** This component has a RoHS exemption for either 1) lead-based flip-chip solder bumps used between the die and package, or 2) lead-based die adhesive used between the die and leadframe. The component is otherwise considered Pb-Free (RoHS compatible) as defined above.

**Green (RoHS & no Sb/Br):** TI defines "Green" to mean Pb-Free (RoHS compatible), and free of Bromine (Br) and Antimony (Sb) based flame retardants (Br or Sb do not exceed 0.1% by weight in homogeneous material)

(3) MSL, Peak Temp. -- The Moisture Sensitivity Level rating according to the JEDEC industry standard classifications, and peak solder temperature.

(4) There may be additional marking, which relates to the logo, the lot trace code information, or the environmental category on the device.

(5) Multiple Device Markings will be inside parentheses. Only one Device Marking contained in parentheses and separated by a "~" will appear on a device. If a line is indented then it is a continuation of the previous line and the two combined represent the entire Device Marking for that device.

**Important Information and Disclaimer:** The information provided on this page represents TI's knowledge and belief as of the date that it is provided. TI bases its knowledge and belief on information provided by third parties, and makes no representation or warranty as to the accuracy of such information. Efforts are underway to better integrate information from third parties. TI has taken and

continues to take reasonable steps to provide representative and accurate information but may not have conducted destructive testing or chemical analysis on incoming materials and chemicals. TI and TI suppliers consider certain information to be proprietary, and thus CAS numbers and other limited information may not be available for release.

In no event shall TI's liability arising out of such information exceed the total purchase price of the TI part(s) at issue in this document sold by TI to Customer on an annual basis.

**OTHER QUALIFIED VERSIONS OF UC1846, UC1847, UC2846, UC2846M, UC3846, UC3846M, UC3847 :**

- Catalog: [UC3846](#), [UC3847](#), [UC2846](#), [UC3846M](#), [UC3846](#)
- Enhanced Product: [UC1846-EP](#), [UC1846-EP](#)
- Military: [UC2846M](#), [UC1846](#), [UC1847](#)
- Space: [UC1846-SP](#), [UC1846-SP](#)

**NOTE: Qualified Version Definitions:**

- Catalog - TI's standard catalog product
- Enhanced Product - Supports Defense, Aerospace and Medical Applications
- Military - QML certified for Military and Defense Applications
- Space - Radiation tolerant, ceramic packaging and qualified for use in Space-based application

## IMPORTANT NOTICE

Texas Instruments Incorporated and its subsidiaries (TI) reserve the right to make corrections, enhancements, improvements and other changes to its semiconductor products and services per JESD46, latest issue, and to discontinue any product or service per JESD48, latest issue. Buyers should obtain the latest relevant information before placing orders and should verify that such information is current and complete. All semiconductor products (also referred to herein as "components") are sold subject to TI's terms and conditions of sale supplied at the time of order acknowledgment.

TI warrants performance of its components to the specifications applicable at the time of sale, in accordance with the warranty in TI's terms and conditions of sale of semiconductor products. Testing and other quality control techniques are used to the extent TI deems necessary to support this warranty. Except where mandated by applicable law, testing of all parameters of each component is not necessarily performed.

TI assumes no liability for applications assistance or the design of Buyers' products. Buyers are responsible for their products and applications using TI components. To minimize the risks associated with Buyers' products and applications, Buyers should provide adequate design and operating safeguards.

TI does not warrant or represent that any license, either express or implied, is granted under any patent right, copyright, mask work right, or other intellectual property right relating to any combination, machine, or process in which TI components or services are used. Information published by TI regarding third-party products or services does not constitute a license to use such products or services or a warranty or endorsement thereof. Use of such information may require a license from a third party under the patents or other intellectual property of the third party, or a license from TI under the patents or other intellectual property of TI.

Reproduction of significant portions of TI information in TI data books or data sheets is permissible only if reproduction is without alteration and is accompanied by all associated warranties, conditions, limitations, and notices. TI is not responsible or liable for such altered documentation. Information of third parties may be subject to additional restrictions.

Resale of TI components or services with statements different from or beyond the parameters stated by TI for that component or service voids all express and any implied warranties for the associated TI component or service and is an unfair and deceptive business practice. TI is not responsible or liable for any such statements.

Buyer acknowledges and agrees that it is solely responsible for compliance with all legal, regulatory and safety-related requirements concerning its products, and any use of TI components in its applications, notwithstanding any applications-related information or support that may be provided by TI. Buyer represents and agrees that it has all the necessary expertise to create and implement safeguards which anticipate dangerous consequences of failures, monitor failures and their consequences, lessen the likelihood of failures that might cause harm and take appropriate remedial actions. Buyer will fully indemnify TI and its representatives against any damages arising out of the use of any TI components in safety-critical applications.

In some cases, TI components may be promoted specifically to facilitate safety-related applications. With such components, TI's goal is to help enable customers to design and create their own end-product solutions that meet applicable functional safety standards and requirements. Nonetheless, such components are subject to these terms.

No TI components are authorized for use in FDA Class III (or similar life-critical medical equipment) unless authorized officers of the parties have executed a special agreement specifically governing such use.

Only those TI components which TI has specifically designated as military grade or "enhanced plastic" are designed and intended for use in military/aerospace applications or environments. Buyer acknowledges and agrees that any military or aerospace use of TI components which have **not** been so designated is solely at the Buyer's risk, and that Buyer is solely responsible for compliance with all legal and regulatory requirements in connection with such use.

TI has specifically designated certain components as meeting ISO/TS16949 requirements, mainly for automotive use. In any case of use of non-designated products, TI will not be responsible for any failure to meet ISO/TS16949.

### Products

Audio	<a href="http://www.ti.com/audio">www.ti.com/audio</a>
Amplifiers	<a href="http://amplifier.ti.com">amplifier.ti.com</a>
Data Converters	<a href="http://dataconverter.ti.com">dataconverter.ti.com</a>
DLP® Products	<a href="http://www.dlp.com">www.dlp.com</a>
DSP	<a href="http://dsp.ti.com">dsp.ti.com</a>
Clocks and Timers	<a href="http://www.ti.com/clocks">www.ti.com/clocks</a>
Interface	<a href="http://interface.ti.com">interface.ti.com</a>
Logic	<a href="http://logic.ti.com">logic.ti.com</a>
Power Mgmt	<a href="http://power.ti.com">power.ti.com</a>
Microcontrollers	<a href="http://microcontroller.ti.com">microcontroller.ti.com</a>
RFID	<a href="http://www.ti-rfid.com">www.ti-rfid.com</a>
OMAP Applications Processors	<a href="http://www.ti.com/omap">www.ti.com/omap</a>
Wireless Connectivity	<a href="http://www.ti.com/wirelessconnectivity">www.ti.com/wirelessconnectivity</a>

### Applications

Automotive and Transportation	<a href="http://www.ti.com/automotive">www.ti.com/automotive</a>
Communications and Telecom	<a href="http://www.ti.com/communications">www.ti.com/communications</a>
Computers and Peripherals	<a href="http://www.ti.com/computers">www.ti.com/computers</a>
Consumer Electronics	<a href="http://www.ti.com/consumer-apps">www.ti.com/consumer-apps</a>
Energy and Lighting	<a href="http://www.ti.com/energy">www.ti.com/energy</a>
Industrial	<a href="http://www.ti.com/industrial">www.ti.com/industrial</a>
Medical	<a href="http://www.ti.com/medical">www.ti.com/medical</a>
Security	<a href="http://www.ti.com/security">www.ti.com/security</a>
Space, Avionics and Defense	<a href="http://www.ti.com/space-avionics-defense">www.ti.com/space-avionics-defense</a>
Video and Imaging	<a href="http://www.ti.com/video">www.ti.com/video</a>

### TI E2E Community

[e2e.ti.com](http://e2e.ti.com)

Mailing Address: Texas Instruments, Post Office Box 655303, Dallas, Texas 75265  
Copyright © 2013, Texas Instruments Incorporated