



LM317

LINEAR INTEGRATED CIRCUIT

HIGH CURRENT 1.3V TO 37V ADJUSTABLE VOLTAGE REGULATOR

DESCRIPTION

The UTC LM317 is an adjustable 3-terminal positive voltage regulator, designed to supply 1A of output current with voltage adjustable from 1.3V ~ 37V.

FEATURES

- *Output voltage adjustable from 1.3V ~ 37V
- *Output current in excess of 1A
- *Internal short circuit protection.
- *Internal over temperature protection.
- *Output transistor safe area compensation

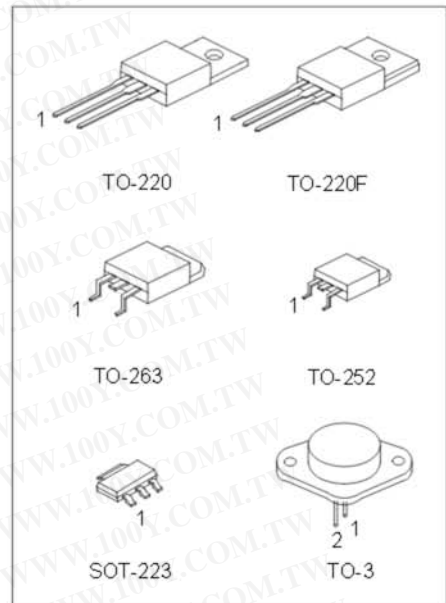

Lead-free: LM317K
Halogen-free: LM317G

ORDERING INFORMATION

Ordering Number			Package	Pin Assignment			Packing
Normal	Lead Free	Halogen Free		1	2	3	
LM317-AA3-R	LM317K-AA3-R	LM317G-AA3-R	SOT-223	ADJ	O	I	Tape Reel
LM317-TA3-T	LM317K-TA3-T	LM317G-TA3-T	TO-220	ADJ	O	I	Tube
LM317-TF3-T	LM317K-TF3-T	LM317G-TF3-T	TO-220F	ADJ	O	I	Tube
LM317-TN3-R	LM317K-TN3-R	LM317G-TN3-R	TO-252	ADJ	O	I	Tape Reel
LM317-TN3-T	LM317K-TN3-T	LM317G-TN3-T	TO-252	ADJ	O	I	Tube
LM317-TQ2-R	LM317K-TQ2-R	LM317G-TQ2-R	TO-263	ADJ	O	I	Tape Reel
LM317-TQ2-T	LM317K-TQ2-T	LM317G-TQ2-T	TO-263	ADJ	O	I	Tube
LM317-T30-Y	LM317K-T30-Y	LM317G-T30-Y	TO-3	I	ADJ	O	Tray

Note: 1. Pin Assignment: I:V_{IN} O:V_{OUT}
2. Pin 3 on TO-3 is case

<p>LM317K-AA3-R</p> <p>(1)Packing Type (2)Package Type (3)Lead Plating</p>	<p>(1) R: Tape Reel, T: Tube, Y: Tray (2) AA3: SOT-223, TA3: TO-220, TF3: TO-220F, TN3: TO-252, TQ2: TO-263, T30: TO-3 (3) G: Halogen Free, K: Lead Free, Blank: Pb/Sn</p>
--	--

勝特力材料 886-3-5753170
 勝特力电子(上海) 86-21-34970699
 勝特力电子(深圳) 86-755-83298787
[Http://www.100y.com.tw](http://www.100y.com.tw)

■ BLOCK DIAGRAM

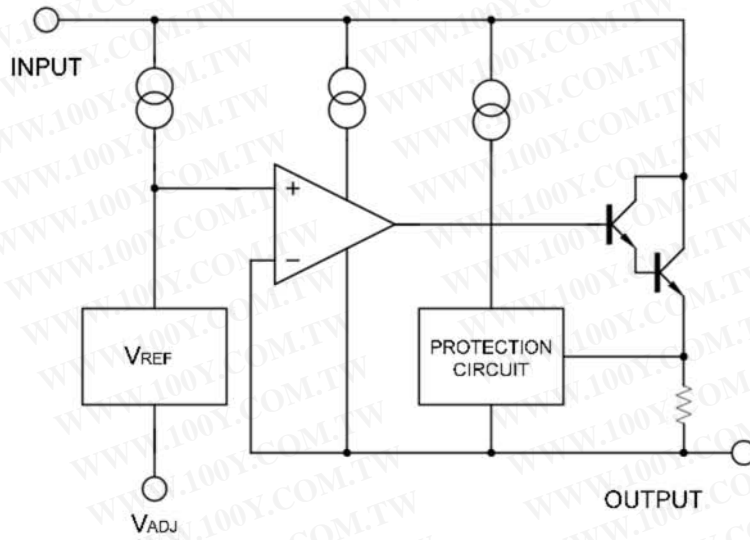

■ ABSOLUTE MAXIMUM RATINGS (Ta=25°C, unless otherwise specified)

PARAMETER	SYMBOL	RATINGS	UNIT
Input - Output Voltage Difference	$V_{IN}-V_{OUT}$	40	V
Power Dissipation	P_D	Internal limited	
Junction Temperature	T_J	+125	°C
Operating Temperature	T_{OPR}	-40 ~ +85	°C
Storage Temperature	T_{STG}	-40 ~ +150	°C

Note:1. Absolute maximum ratings are stress ratings only and functional device operation is not implied. The device could be damaged beyond Absolute maximum ratings.

■ THERMAL DATA

PARAMETER	SYMBOL	RATINGS	UNIT
Junction-to-Ambient	TO-252	112	°C/W
	TO-220/TO-220F	54	
	TO-263	64	
	SOT-223	165	
	TO-3	35	
Junction-to-Case	TO-252	12	°C/W
	TO-220/TO-220F	5	
	TO-263	5	
	SOT-223	23	
	TO-3	3	

■ ELECTRICAL CHARACTERISTICS

($V_{IN}-V_{OUT}=5V$, $I_{OUT}=10mA$, $T_a=25^\circ C$, unless otherwise specified.)

PARAMETER	SYMBOL	TEST CONDITIONS	MIN	TYP	MAX	UNIT
Line Regulation	$\Delta V_{OUT}/V_{OUT}$	$3V \leq V_{IN}-V_{OUT} \leq 40V$		0.01	0.04	%/V
Load Regulation	ΔV_{OUT}	$10mA \leq I_{OUT} \leq 1A$	$V_{OUT} \leq 5V$	5	25	mV
			$V_{OUT} \geq 5V$	0.1	0.5	%
Adjustable Pin Current	I_{ADJ}			50	100	μA
Adjustable Pin Current Change	ΔI_{ADJ}	$3V \leq V_{IN}-V_{OUT} \leq 40V$, $10mA \leq I_{OUT} \leq 1A$, $P_D \leq 20W$		0.2	5	μA
Reference Voltage	V_{REF}	$3V \leq V_{IN}-V_{OUT} \leq 40V$, $10mA \leq I_{OUT} \leq 1A$, $P_D \leq 20W$	1.20	1.25	1.30	V
Temperature Stability		$T_{MIN} \leq T_J \leq T_{MAX}$		0.7		%/V _{OUT}
Minimum Load Current for Regulation	$I_{L(MIN)}$	$V_{IN}-V_{OUT}=40V$		3.5	10	mA
Maximum Output Current	$I_{O(MAX)}$	$V_{IN}-V_{OUT}=40V$, $P_D \leq 20W$	0.2	0.3		A
RMS Noise vs. % of V_{OUT}	eN	$10Hz \leq f \leq 10KHz$		0.003		%/V _{OUT}
Ripple Rejection	RR	$V_{OUT}=10V, f=120Hz$	$C_{ADJ}=0$		65	dB
			$C_{ADJ}=10\mu F$	66	80	

Note: C_{ADJ} is connected between Adjust pin and Ground.

APPLICATION CIRCUITS

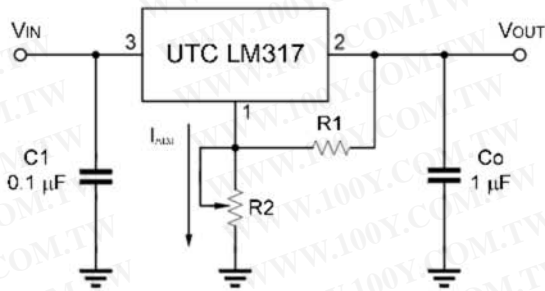

Fig.1 Programmable voltage regulator

$V_{OUT} = 1.25V \cdot (1 + R2/R1) + I_{ADJ} \cdot R2$
 C1 is required when regulator is located an appreciated distance from power supply. Co is needed to improve transient response.

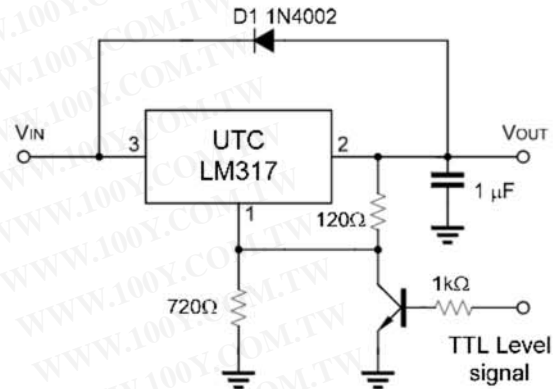

Fig.2 Regulator with On-off control

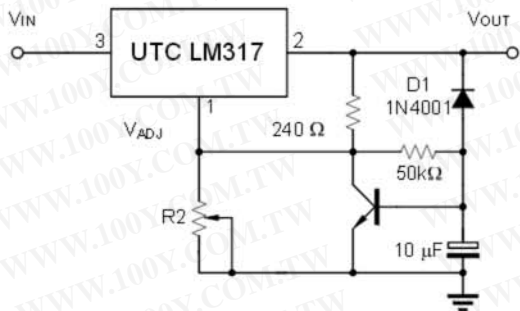
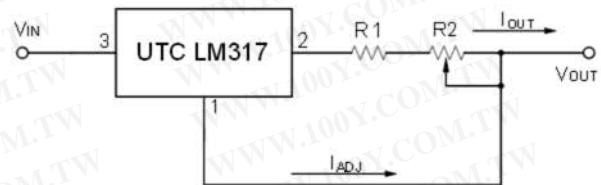

Fig.3 Soft Start Application



$$I_{O(MAX)} = \left(\frac{V_{REF}}{R1} \right) + I_{ADJ} = \frac{1.25V}{R1}$$

$$I_{O(MIN)} = \left(\frac{V_{REF}}{R1 + R2} \right) + I_{ADJ} = \frac{1.25V}{R1 + R2}$$

$$5mA < I_{OUT} < 100mA$$

Fig.4 Constant Current Application

TYPICAL CHARACTERISTICS

Load Regulation vs. temperature

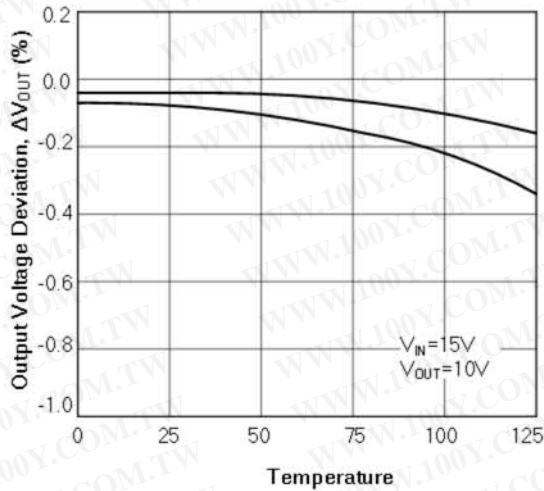

Adjustment Current vs. Temperature

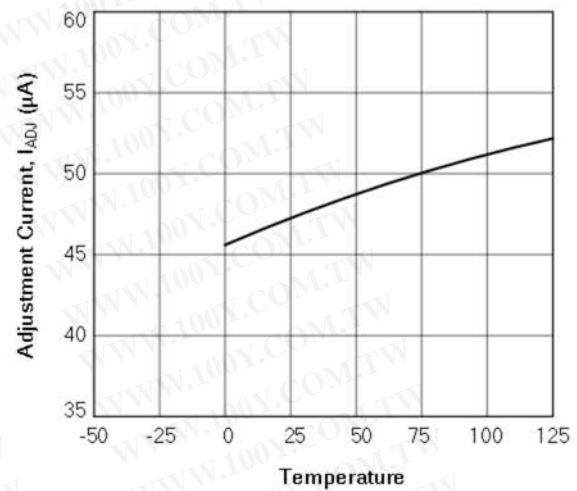

Current Limit

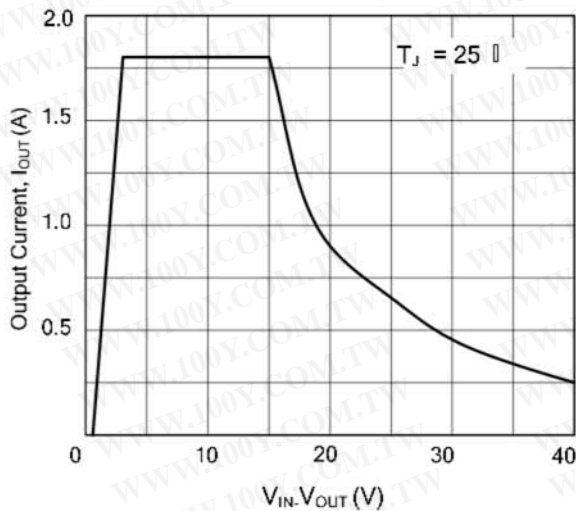

Minimum Operating Current

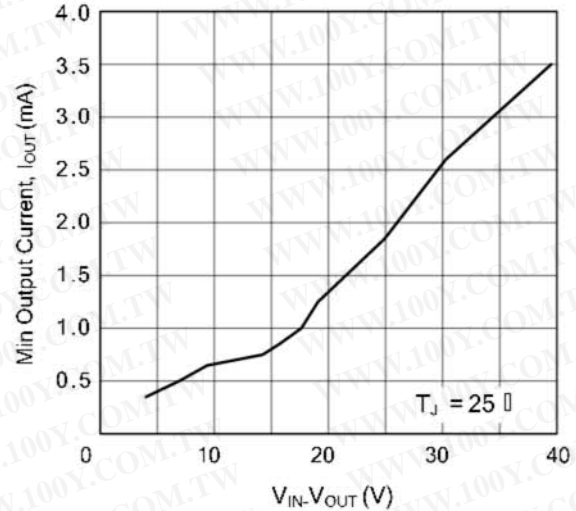

勝特力材料 886-3-5753170
 勝特力电子(上海) 86-21-34970699
 勝特力电子(深圳) 86-755-83298787
[Http://www.100y.com.tw](http://www.100y.com.tw)

UTC assumes no responsibility for equipment failures that result from using products at values that exceed, even momentarily, rated values (such as maximum ratings, operating condition ranges, or other parameters) listed in products specifications of any and all UTC products described or contained herein. UTC products are not designed for use in life support appliances, devices or systems where malfunction of these products can be reasonably expected to result in personal injury. Reproduction in whole or in part is prohibited without the prior written consent of the copyright owner. The information presented in this document does not form part of any quotation or contract, is believed to be accurate and reliable and may be changed without notice.