

CMOS 14-Stage Ripple-Carry Binary Counter/Divider and Oscillator

High-Voltage Types (20-Volt Rating)

勝特力材料 886-3-5753170
 勝特力电子(上海) 86-21-54151736
 勝特力电子(深圳) 86-755-83298787
[Http://www.100y.com.tw](http://www.100y.com.tw)

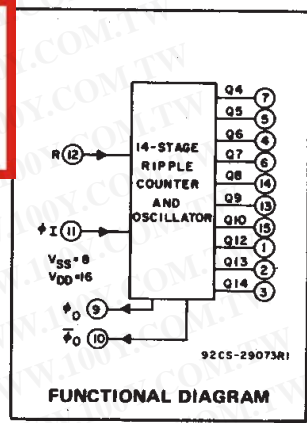

■ CD4060B consists of an oscillator section and 14 ripple-carry binary counter stages. The oscillator configuration allows design of either RC or crystal oscillator circuits. A RESET input is provided which resets the counter to the all-0's state and disables the oscillator. A high level on the RESET line accomplishes the reset function. All counter stages are master-slave flip-flops. The state of the counter is advanced one step in binary order on the negative transition of ϕI (and ϕQ). All inputs and outputs are fully buffered. Schmitt trigger action on the input-pulse line permits unlimited input-pulse rise and fall times.

The CD4060B-series types are supplied in 16-lead hermetic dual-in-line ceramic packages (D and F suffixes), 16-lead dual-in-line plastic packages (E suffix), and in chip form (H suffix).

Features:

- 12 MHz clock rate at 15 V
- Common reset
- Fully static operation
- Buffered inputs and outputs
- Schmitt trigger input-pulse line
- 100% tested for quiescent current at 20 V
- Standardized, symmetrical output characteristics
- 5-V, 10-V, and 15-V parametric ratings
- Meets all requirements of JEDEC Tentative Standard No. 13B, "Standard Specifications for description of "B" Series CMOS Devices"

Oscillator Features:

- All active components on chip
- RC or crystal oscillator configuration
- RC oscillator frequency of 690 kHz min. at 15 V

Applications

- Control counters
- Timers
- Frequency dividers
- Time-delay circuits

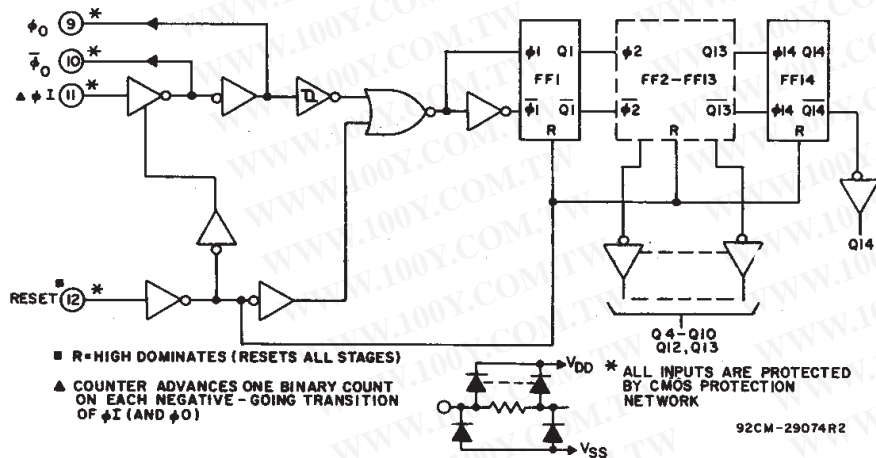

Fig.1 - Logic diagram.

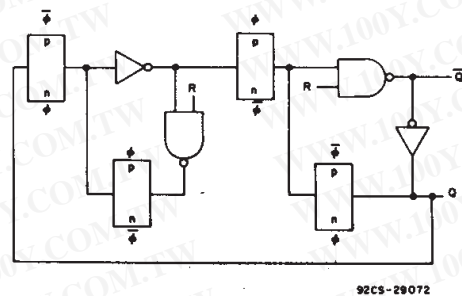

Fig. 2 - Detail of typical flip-flop stage.

MAXIMUM RATINGS, Absolute-Maximum Values:

DC SUPPLY-VOLTAGE RANGE, (V _{DD})	-0.5V to +20V
Voltages referenced to V _{SS} Terminal)	
INPUT VOLTAGE RANGE, ALL INPUTS	-0.5V to V _{DD} +0.5V
DC INPUT CURRENT, ANY ONE INPUT	±10mA
POWER DISSIPATION PER PACKAGE (P _D):	
For T _A = -55°C to +100°C	500mW
For T _A = +100°C to +125°C	Derate Linearly at 12mW/°C to 200mW
DEVICE DISSIPATION PER OUTPUT TRANSISTOR	
FOR T _A = FULL PACKAGE-TEMPERATURE RANGE (All Package Types)	100mW
OPERATING-TEMPERATURE RANGE (T _A)	-55°C to +125°C
STORAGE TEMPERATURE RANGE (T _{stg})	-65°C to +150°C
LEAD TEMPERATURE (DURING SOLDERING):	
At distance 1/16 ± 1/32 inch (1.59 ± 0.79mm) from case for 10s max	+265°C

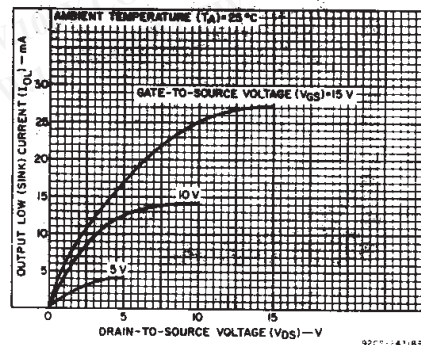

Fig. 3 - Typical n-channel output low (sink) current characteristics.

CD4060B Types

勝特力材料 886-3-5753170
 勝特力电子(上海) 86-21-54151736
 勝特力电子(深圳) 86-755-83298787
 Http://www.100y.com.tw

STATIC ELECTRICAL CHARACTERISTICS

CHARACTERISTIC	CONDITIONS			LIMITS AT INDICATED TEMPERATURES (°C)							UNITS
	V _O (V)	V _{IN} (V)	V _{DD} (V)	-55	-40	+85	+125	+25			
								Min.	Typ.	Max.	
Quiescent Device Current, I _{DD} Max.	-	0.5	5	5	5	150	150	-	0.04	5	μA
	-	0.10	10	10	10	300	300	-	0.04	10	
	-	0.15	15	20	20	600	600	-	0.04	20	
	-	0.20	20	100	100	3000	3000	-	0.08	100	
Output Low (Sink) Current*, I _{OL} Min.	0.4	0.5	5	0.64	0.61	0.42	0.36	0.51	1	-	mA
	0.5	0.10	10	1.6	1.5	1.1	0.9	1.3	2.6	-	
	1.5	0.15	15	4.2	4	2.8	2.4	3.4	6.8	-	
Output High (Source) Current*, I _{OH} Min.	4.6	0.5	5	-0.64	-0.61	-0.42	-0.36	-0.51	-1	-	mA
	2.5	0.5	5	-2	-1.8	-1.3	-1.15	-1.6	-3.2	-	
	9.5	0.10	10	-1.6	-1.5	-1.1	-0.9	-1.3	-2.6	-	
	13.5	0.15	15	-4.2	-4	-2.8	-2.4	-3.4	-6.8	-	
Output Voltage: Low-Level, V _{OL} Max.	-	0.5	5	0.05			-	0	0.05	-	V
	-	0.10	10	0.05			-	0	0.05	-	
	-	0.15	15	0.05			-	0	0.05	-	
Output Voltage: High-Level, V _{OH} Min.	-	0.5	5	4.95			4.95	5	-	-	V
	-	0.10	10	9.95			9.95	10	-	-	
	-	0.15	15	14.95			14.95	15	-	-	
Input Low Voltage V _{IL} Max.	0.5, 4.5	-	5	1.5			-	-	1.5	-	V
	1.9	-	10	3			-	-	3	-	
	1.5, 13.5	-	15	4			-	-	4	-	
Input High Voltage, V _{IH} Min.	0.5, 4.5	-	5	3.5			3.5	-	-	-	V
	1.9	-	10	7			7	-	-	-	
	1.5, 13.5	-	15	11			11	-	-	-	
Input Current I _{IN} Max.	-	0.18	18	±0.1	±0.1	±1	±1	-	±10 ⁻⁵	±0.1	μA

* Data not applicable to terminal 9 or 10.

RECOMMENDED OPERATING CONDITIONS

For maximum reliability, nominal operating conditions should be selected so that operation is always within the following ranges

CHARACTERISTIC	V _{DD}	LIMITS		UNITS
		MIN.	MAX.	
Supply-Voltage Range (For T _A = Full Package Temperature Range)	-	3	18	V
Input-Pulse Width, t _W (f = 100 kHz)	5	100	-	ns
	10	40	-	
	15	30	-	
Input-Pulse Rise Time and Fall Time, t _{rφ} , t _{fφ}	5	Unlimited		
	10			
	15			
Input-Pulse Frequency, f _{φI} (External pulse source)	5	-	3.5	MHz
	10	-	8	
	15	-	12	
Reset Pulse Width, t _W	5	120	-	ns
	10	60	-	
	15	40	-	

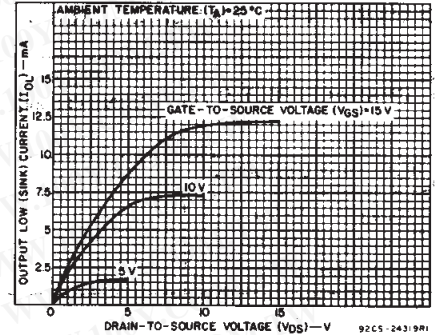

Fig. 4 - Minimum n-channel output low (sink) current characteristics.

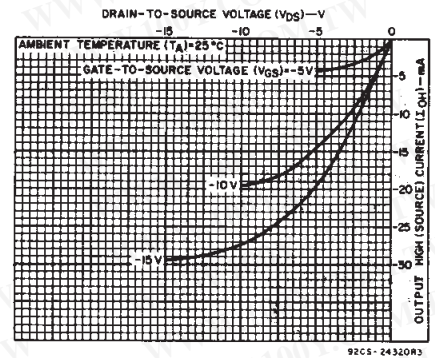

Fig. 5 - Typical p-channel output high (source) current characteristics.

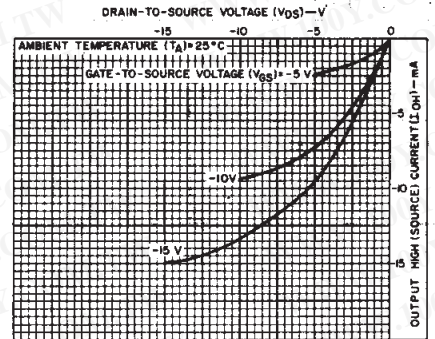

Fig. 6 - Minimum p-channel output high (source) current characteristics.

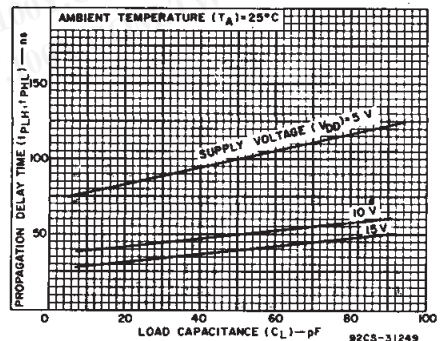

Fig. 7 - Typical propagation delay time (Q_n to Q_{n+1}) as a function of load capacitance.

3
 COMMERCIAL CMOS
 HIGH VOLTAGE ICs

CD4060B Types

勝特力材料 886-3-5753170
 勝特力电子(上海) 86-21-54151736
 勝特力电子(深圳) 86-755-83298787
 Http://www.100y.com.tw

DYNAMIC ELECTRICAL CHARACTERISTICS at $T_A = 25^\circ\text{C}$, Input $t_r, t_f = 20\text{ ns}$,
 $C_L = 50\text{ pF}$, $R_L = 200\text{ k}\Omega$

CHARACTERISTIC	TEST CONDITIONS	LIMITS			UNITS	
		V _{DD} (V)	MIN.	TYP.		MAX.
Input-Pulse Operation						
Propagation Delay Time, ϕ_I to Q4 Out; t_{PHL}, t_{PLH}		5	—	370	740	
		10	—	150	300	
		15	—	100	200	
Propagation Delay Time, Q _n to Q _{n+1} ; t_{PHL}, t_{PLH}		5	—	100	200	
		10	—	50	100	
		15	—	40	80	
Transition Time, t_{THL}, t_{TLH}		5	—	100	200	ns
		10	—	50	100	
		15	—	40	80	
Min. Input-Pulse Width, t_W	f = 100 kHz	5	—	50	100	
		10	—	20	40	
		15	—	15	30	
Input-Pulse Rise & Fall Time, $t_{r\phi}, t_{f\phi}$		5	Unlimited			
		10				
		15				
Max. Input-Pulse Frequency, $f_{\phi I}$ (External pulse source)		5	3.5	7	—	MHz
		10	8	16	—	
		15	12	24	—	
Input Capacitance, C _I	Any Input		—	5	7.5	pF
Reset Operation						
Propagation Delay Time, t_{PHL}		5	—	180	360	ns
		10	—	80	160	
		15	—	50	100	
Minimum Reset Pulse Width, t_W		5	—	60	120	
		10	—	30	60	
		15	—	20	40	

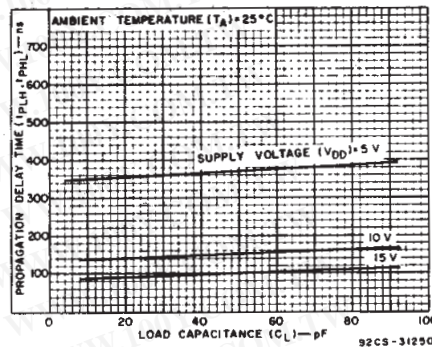

Fig. 8 - Typical propagation delay time (ϕ_I to Q₄ Output) as a function of load capacitance.

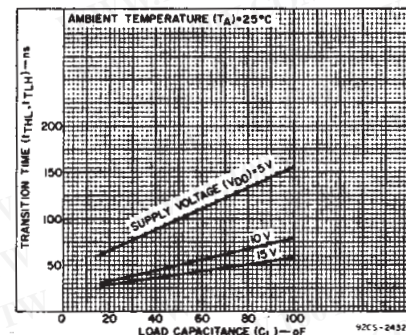

Fig. 9 - Typical transition time as a function of load capacitance.

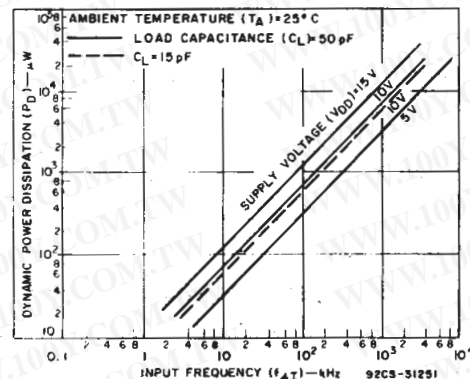

Fig. 10 - Typical dynamic power dissipation as a function of input frequency.

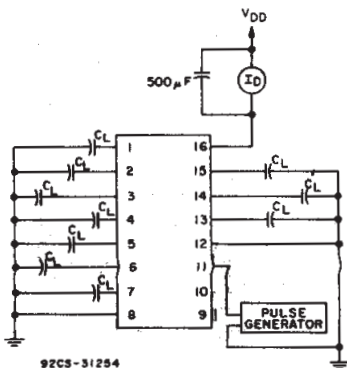

Fig. 11 - Dynamic power dissipation test circuit.

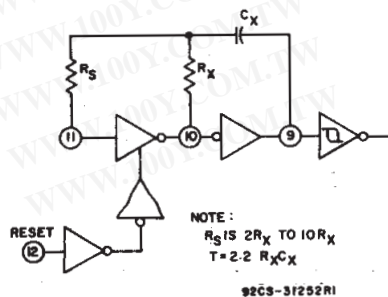

Fig. 12 - Typical RC circuit.

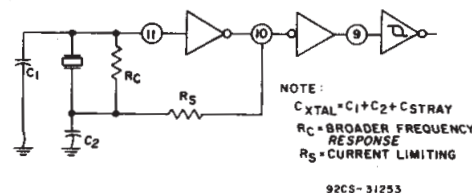

Fig. 13 - Typical crystal circuit.

CD4060B Types

DYNAMIC ELECTRICAL CHARACTERISTICS at $T_A = 25^\circ\text{C}$, Input $t_r, t_f = 20 \text{ ns}$, $C_L = 50 \text{ pF}$, $R_L = 200 \text{ k}\Omega$ [cont'd]

CHARACTERISTIC	TEST CONDITIONS	VDD (V)	LIMITS			UNITS	
			Min.	Typ.	Max.		
RC Operation							
Variation of Frequency (Unit-to-Unit)	$C_X = 200 \text{ pF}$, $R_S = 560 \text{ k}\Omega$, $R_X = 50 \text{ k}\Omega$	5	—	$23 \pm 10\%$	—	kHz	
		10	—	$24 \pm 10\%$	—		
		15	—	$25 \pm 10\%$	—		
Variation of Frequency with voltage change (Same Unit)	$C_X = 200 \text{ pF}$, $R_S = 560 \text{ k}\Omega$, $R_X = 50 \text{ k}\Omega$	5V to 10 V	—	1.5	—	kHz	
		10V to 15V	—	0.5	—		
R _X max.	$C_X = 10 \mu\text{F}$ = $50 \mu\text{F}$ = $10 \mu\text{F}$	5	—	—	20	M Ω	
		10	—	—	20		
		15	—	—	10		
C _X max.	$R_X = 500 \text{ k}\Omega$ = $300 \text{ k}\Omega$ = $300 \text{ k}\Omega$	5	—	—	1000	μF	
		10	—	—	50		
		15	—	—	50		
Maximum Oscillator Frequency*	$R_X = 5 \text{ k}\Omega$ $R_S = 30 \text{ k}\Omega$ $C_X = 15 \text{ pF}$	10	530	650	810	kHz	
		15	690	800	940		
Drive Current at Pin 9 (For Oscillator Design)	I _{OL}	V _O = 0.4 V	5	0.16	0.35	—	mA
		= 0.5 V	10	0.42	0.8	—	
		= 1.5 V	15	1	2	—	
	I _{OH}	V _O = 4.6 V	5	-0.16	-0.35	—	
		= 9.5 V	10	-0.42	-0.8	—	
		= 13.5 V	15	-1	-2	—	

*RC oscillator applications are not recommended at supply voltages below 7 V for $R_X < 50 \text{ k}\Omega$.

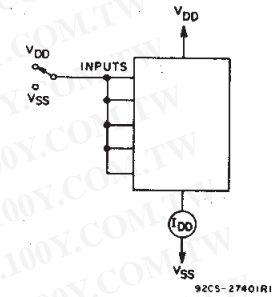

Fig. 14 – Quiescent device current.

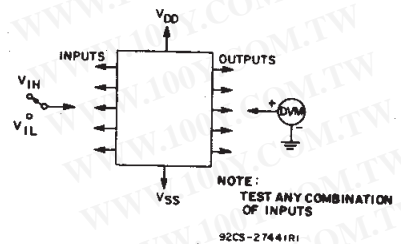

Fig. 15 – Input voltage.

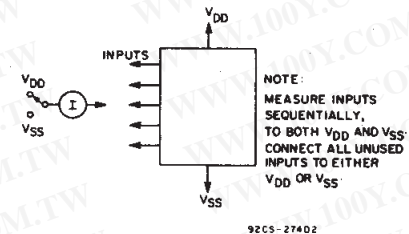
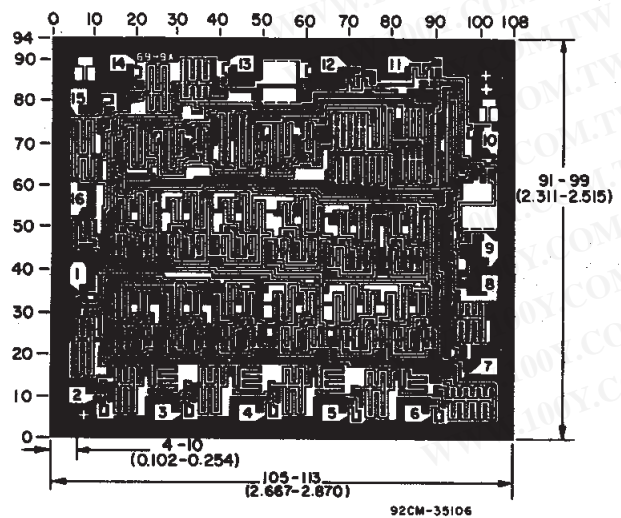

Fig. 16 – Input current.

3
COMMERCIAL CMOS
HIGH VOLTAGE ICs



Chip dimensions and pad layout for CD4060B

TERMINAL DIAGRAM

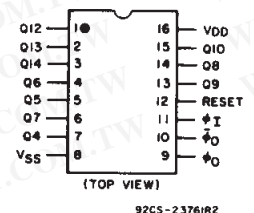

Dimensions in parentheses are in millimeters and are derived from the basic inch dimensions as indicated. Grid graduations are in mils (10⁻³ inch).