

Features

- Package Size: 1.6*1.2 2.0*1.6 2.5*2.0 3.2*2.5
5.0*3.2 7.0*5.0mm
- Frequency range: 1MHz ~ 54MHz.
- Ultra Small SMD seam sealed crystal oscillator units.
- Applications: WLAN, Bluetooth, DSC, DSL and other IT product.

Electrical Specifications

Item / Type	YSO110TR
Output Frequency Range	1~54MHz or specify
Output Type	CMOS
Supply Voltage	1.8V ~ 3.3V
Oscillation Mode	Fundamental
Frequency Tolerance (at 25 °C)	±10ppm, ±20ppm, or specify
Output Load	15pF, or specify
Operating Temperature Range	-40~+85°C, -40~+125°C, or specify
Frequency Versus Temperature Characteristics	± 20ppm, ± 30ppm, ± 50ppm, or specify
Storage Temperature Range	- 55 ~ + 125 °C
Voltage Vol (Max.) / Vol (Min.)	90%Vdd min./10%Vdd max
Symmetry	45~55%
Rise (Tr) / Fall (Tf) Time	4ns Max.
Start-up Time	3 msMax.
Supply Current	See Below
Frequency Aging (at 25 °C)	± 3 ppm / year Max.

Dimensions

PAD	#1	#2	#3	#4
FUNCTION	Tri-state	GND	OUTPUT	VDD

Notes:

1. To maintain stable operation provide a 0.01uF to 0.1uF by-pass capacitor at a location as near as possible to the power source terminal of the crystal product(between Vcc-GND)

Top View

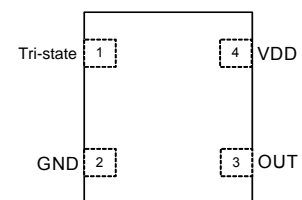
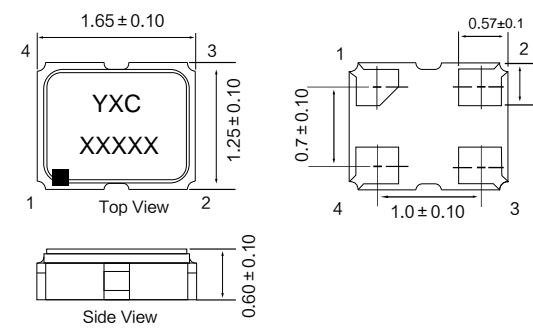
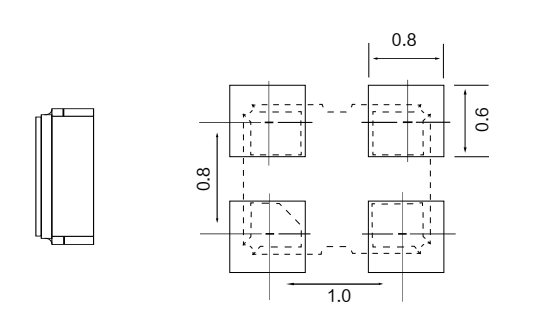

Figure 1. Pin Assignments

Package Size -- Dimensions(Unit:mm)	Recommended layout Pattern (Unit:mm)
1.6x1.2x0.60mm 	

Package Size -- Dimensions(Unit:mm)	Recommended layout Pattern (Unit:mm)
<p>2.0x1.6x0.80mm</p>	<p>TOP View Suggested Layout</p>
<p>2.5x2.0x0.90mm</p>	<p>TOP View Suggested Layout</p>
<p>3.2x2.5x1.00mm</p>	<p>TOP View Suggested Layout</p>
<p>5.0x3.2x1.20mm</p>	<p>TOP View Suggested Layout</p>
<p>7.0x5.0x1.30mm</p>	<p>TOP View Suggested Layout</p>

★ PART NUMBER GUIDE 部件号示例 e.g. OT252028.888MJBA4SL YSO110TR=2.5×2.0 SMD SEAM TYPE

Quartz Crystal Oscillator	Type Code	Package Size	Frequency (Hz)	Supply Voltage (V)	Frequency Stability Overall (ppm)	Output	Pin	Material	Operating Temp. Frequency Temp
O	T	1612 2016 2520 3225 5032 7050	28.888M	J	B	A	4	S	L

★ INPUT CURRENT 工作电流

		Vdc=1.8~3.3V		15pF only	
Voltage	Frequency Size	1~40MHZ		41~54MHZ	
		7050/5032/3225	2520/2016/1612	7050/5032/3225/2520	2016/1612
1.8V		4mA max	4mA max	9mA max	10mA max
2.5V		4.5mA max		10mA max	
3.3V		5mA max		12mA max	

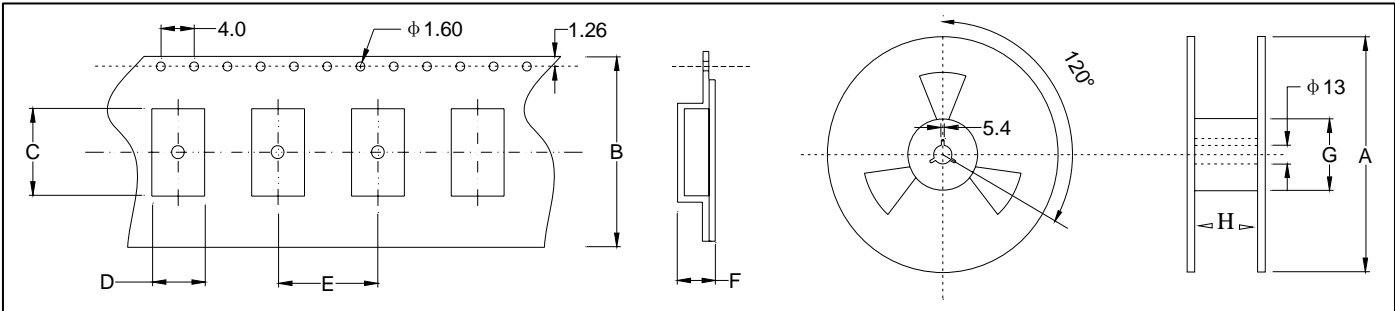
★ TAPING SPECIFICATION (Unit: mm) 编带规格

Size	A	B	C	D	E	F	G	H
OSC-SMD7050 1000 pcs	180±2.0	16.0±0.3	7.50±0.10	5.50±0.10	8.00±0.1	2.00±0.1	61.0±1.0	16.0±3.0
OSC-SMD5032 1000 pcs	180±2.0	12.0±0.3	5.40±0.10	3.60±0.10	8.00±0.3	1.70±0.1	61.0±1.0	12.0±1.0
OSC-SMD3225 3000 pcs	180±2.0	8.0±0.3	3.40±0.10	2.70±0.10	4.00±0.1	1.50±0.1	61.0±1.0	8.0±1.0
OSC-SMD2520 3000 pcs	180±2.0	8.0±0.3	2.90±0.10	2.40±0.10	4.00±0.1	1.20±0.1	61.0±1.0	8.0±1.0
OSC-SMD2016 3000 pcs	180±2.0	8.0±0.3	2.30±0.10	1.90±0.10	3.85±0.1	0.95±0.1	61.0±1.0	8.0±1.0
OSC-SMD1612 3000 pcs	180±2.0	8.0±0.3	1.80±0.10	1.40±0.10	4.00±0.1	0.80±0.1	61.0±1.0	8.0±1.0

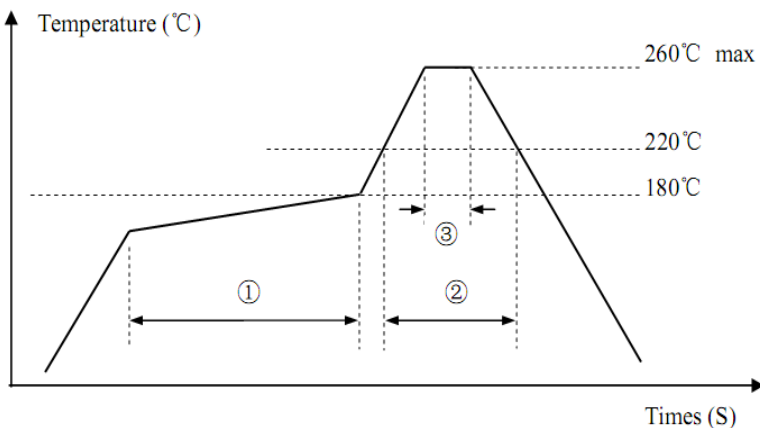
★ REFLOW SOLDERING PROFILE 回流焊特性

Pb free reflow	①	Preheat	160~180°C	120sec. max
A	②	Primary heat	220°C	60sec. max
	③	Peak	260°C	10sec. max.

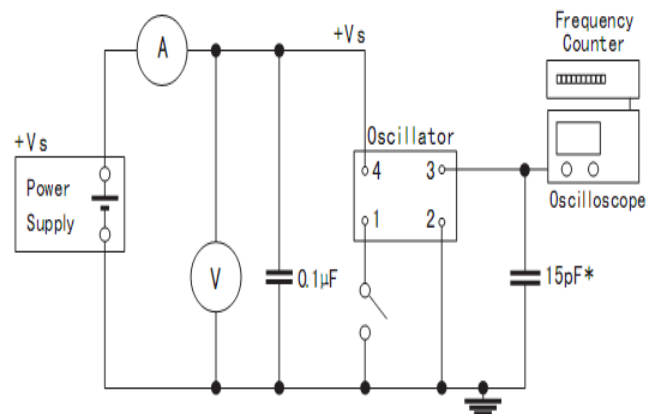
★ Test Circuit 测试电路

勝特力材料 886-3-5773766
 勝特力电子(上海) 86-21-34970699
 勝特力电子(深圳) 86-755-83298787
[Http://www.100y.com.tw](http://www.100y.com.tw)