

Current Transducer LF 205-S/SP1

For the electronic measurement of currents: DC, AC, pulsed..., with galvanic separation between the primary circuit and the secondary circuit.

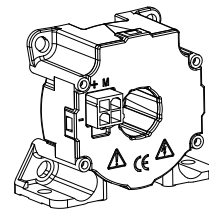

$I_{PN} = 200 \text{ A}$



Electrical data

I_{PN}	Primary nominal RMS current	200	A				
I_{PM}	Primary current, measuring range	0 ... ± 420	A				
R_M	Measuring resistance @	$T_A = 70^\circ\text{C}$		$T_A = 85^\circ\text{C}$			
			$R_{M \min}$	$R_{M \max}$	$R_{M \min}$	$R_{M \max}$	
		with $\pm 12 \text{ V}$	@ $\pm 200 \text{ A}_{\max}$	0	71	0	69
			@ $\pm 420 \text{ A}_{\max}$	0	14	0	12
	with $\pm 15 \text{ V}$	@ $\pm 200 \text{ A}_{\max}$	0	100	23	98	
		@ $\pm 420 \text{ A}_{\max}$	0	28	23	26	
I_{SN}	Secondary nominal RMS current	100	mA				
N_P/N_S	Turns ratio	1 : 2000					
U_C	Supply voltage (+5 %)	$\pm 12 \dots 15$	V				
I_C	Current consumption @ $\pm 15 \text{ V}$	$17 + I_S$	mA				

Accuracy - Dynamic performance data

ε_{tot}	Total error @ I_{PN} , $T_A = 25^\circ\text{C}$	± 0.5	%
ε_L	Linearity error	< 0.1	%
I_O	Offset current @ $I_P = 0$, $T_A = 25^\circ\text{C}$	Typ	± 0.2
		Max	± 0.2
I_{OM}	Magnetic offset current ¹⁾ @ $I_P = 0$ and specified R_M , after an overload of $3 \times I_{PN}$		± 0.1
I_{OT}	Temperature variation of I_O $-40^\circ\text{C} \dots +85^\circ\text{C}$	± 0.12	± 0.4
t_{D10}	Delay time to 10 % of the final output value for I_{PN} step < 500		ns
t_{D90}	Delay time to 90 % of the final output value for I_{PN} step ²⁾ < 1		μs
BW	Frequency bandwidth (-3 dB)	DC ... 100	kHz

General data

T_A	Ambient operating temperature	$-40 \dots +85$	$^\circ\text{C}$
T_{Ast}	Ambient storage temperature	$-40 \dots +90$	$^\circ\text{C}$
R_S	Resistance of secondary winding @ $T_A = 70^\circ\text{C}$	33	Ω
		@ $T_A = 85^\circ\text{C}$	35
m	Mass Standards	78	g
		EN 50178: 1997 ³⁾	
		EN 50155: 2017 ⁴⁾	
		EN 50121-3-2: 2016	

- Notes:
- ¹⁾ The result of the coercive force of the magnetic circuit
 - ²⁾ For a $di/dt = 100 \text{ A}/\mu\text{s}$
 - ³⁾ Excepted test according to chapter 10.2.6.2 (Test equipment according to IEC 61000-4-5)
 - ⁴⁾ Additional information available on request.

Features

- Closed loop (compensated) current transducer using the Hall effect
- Insulating plastic case recognized according to UL 94-V0.

Special feature

- Connection to secondary circuit on MOLEX MINIFIT 5566 or equivalent.

Advantages

- Excellent accuracy
- Very good linearity
- Low temperature drift
- Optimized response time
- Wide frequency bandwidth
- No insertion losses
- High immunity to external interference
- Current overload capability.

Applications

- AC variable speed drives and servo motor drives
- Static converters for DC motor drives
- Battery supplied applications
- Uninterruptible Power Supplies (UPS)
- Switched Mode Power Supplies (SMPS)
- Power supplies for welding applications
- Single or three phase inverters
- Propulsion and braking choppers
- Propulsion converters
- Auxiliary converters
- Battery chargers.

Application domains

- Industrial
- Railway (fixed installations and onboard).

Current Transducer LF 205-S/SP1

Insulation coordination

U_d	RMS voltage for AC insulation test, 50/60 Hz, 1 min	3.5	kV
U_{Ni}	Impulse withstand voltage 1.2/50 μ s	8.8	kV
		Min	
d_{cp}	Creepage distance	9.5	mm
d_{cl}	Clearance	9.5	mm
CTI	Comparative Tracking Index (group IIIa)	175	

Applications examples

According to EN 50178 and IEC 61010-1 standards and following conditions:

- Over voltage category OV 3
- Pollution degree PD2
- Non-uniform field

	EN 50178	IEC 61010-1
d_{cp} , d_{cl} , U_{Ni}	Rated insulation voltage	Nominal voltage
Basic insulation	800 V	800 V
Reinforced insulation	400 V	300 V

Safety

This transducer must be used in limited-energy secondary circuits according to IEC 61010-1.



This transducer must be used in electric/electronic equipment with respect to applicable standards and safety requirements in accordance with the manufacturer's operating instructions.



Caution, risk of electrical shock

When operating the transducer, certain parts of the module can carry hazardous voltage (eg. primary busbar, power supply).

Ignoring this warning can lead to injury and/or cause serious damage.

This transducer is a build-in device, whose conducting parts must be inaccessible after installation.

A protective housing or additional shield could be used.

Main supply must be able to be disconnected.

Dimensions LF 205-S/SP1 (in mm)

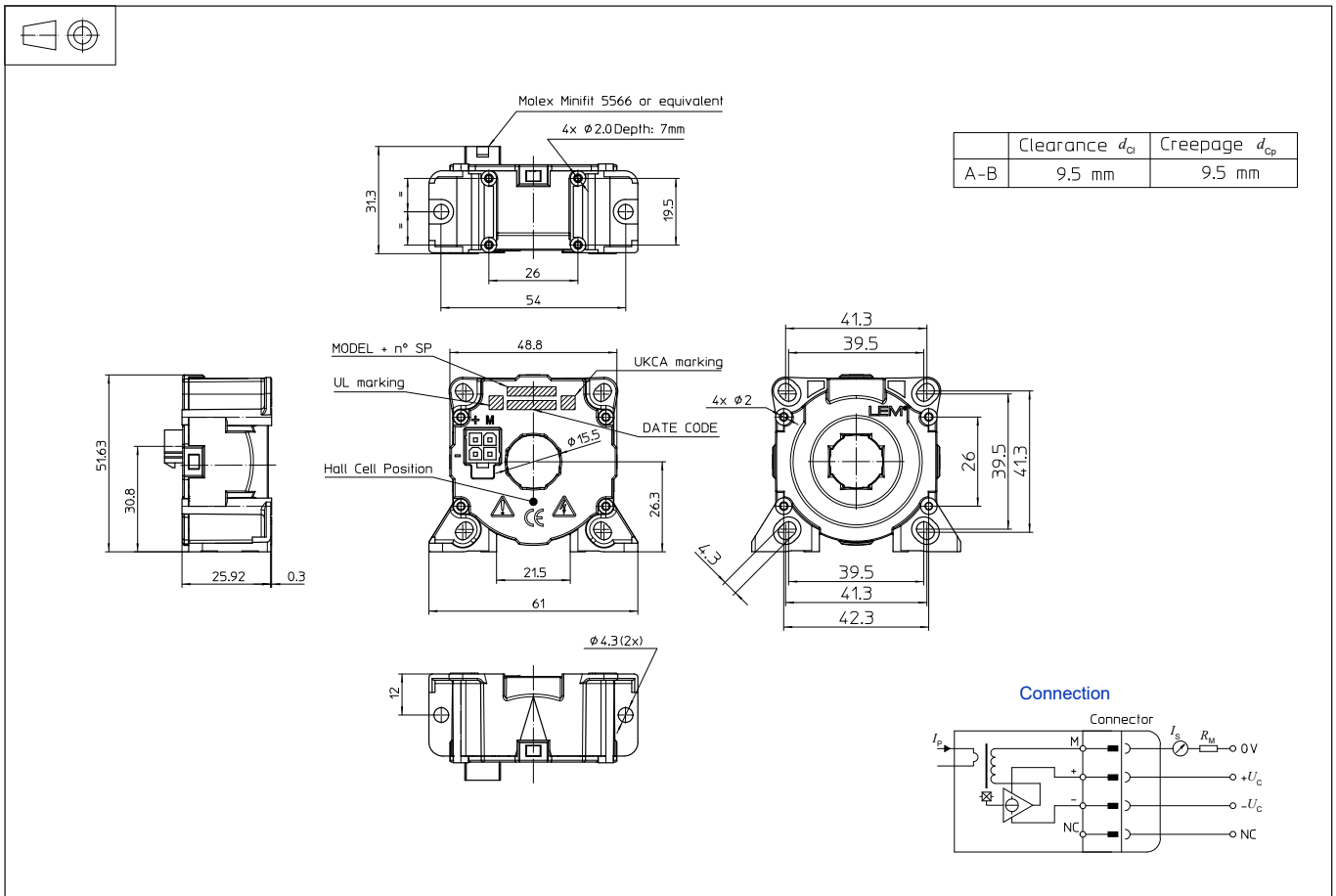

Mechanical characteristics

- General tolerance ± 0.2 mm
- Transducer fastening
 - Vertical position
 - 2 holes $\varnothing 4.3$ mm
 - 2 M4 steel screws
 - Recommended fastening torque 1.5 N·m
 - Or
 - 4 holes $\varnothing 2.0$ mm
 - depth: 7 mm
 - 4 screws PTKA 25
 - length: 6 mm
 - Recommended fastening torque 0.7 N·m
 - Horizontal position
 - 4 holes $\varnothing 4.3$ mm
 - 4 M4 steel screws
 - Recommended fastening torque 1.5 N·m
 - Or
 - 4 holes $\varnothing 2.0$ mm
 - 4 screws PTKA 25
 - min length: 11.5 mm with thickness of fixed plate
 - Recommended fastening torque 0.7 N·m
- Primary through-hole $\varnothing 15.5$ mm
- Connection of secondary Molex Minifit 5566 or equivalent

Remarks

- I_s is positive when I_p flows in the direction of the arrow.
- Temperature of the primary conductor should not exceed 100 °C.
- Installation of the transducer must be done unless otherwise specified on the datasheet, according to LEM Transducer Generic Mounting Rules. Please refer to LEM document N°ANE120504 available on our Web site: <https://www.lem.com/en/file/3137/download>.
- Dynamic performances (di/dt and delay time) are best with a single bar completely filling the primary hole.