

勝特力材料 886-3-5753170
 勝特力电子(上海) 86-21-34970699
 勝特力电子(深圳) 86-755-83298787
[Http://www.100y.com.tw](http://www.100y.com.tw)

A. SCOPE

This specification applies piezo buzzer, **MRE-PB1475-1**

B. SPECIFICATION

No.	Item	Unit	Specification	Condition
1	Oscillation Frequency	KHz	4.0±0.5	
2	Operating Voltage	V _{DC}	3~16	
3	Rated Voltage	V _{DC}	12	
4	Current Consumption	mA	MAX. 7	at Rated Voltage
5	Sound Pressure Level	dB	MIN. 83	at 10cm at Rated Voltage
6	Tone Nature		Single	
7	Operating Temperature	°C	-20~ +70	
8	Storage Temperature	°C	-30 ~ +80	
9	Dimension	mm	Φ13.8 x H7.5	See appearance drawing
10	Weight (MAX)	gram	2.0	
11	Housing Material		PPO(Black)	
12	Leading Pin		Tin Plated Brass(Sn)	See appearance drawing
13	Environmental Protection Regulation		RoHS	

C. APPEARANCE DRAWING

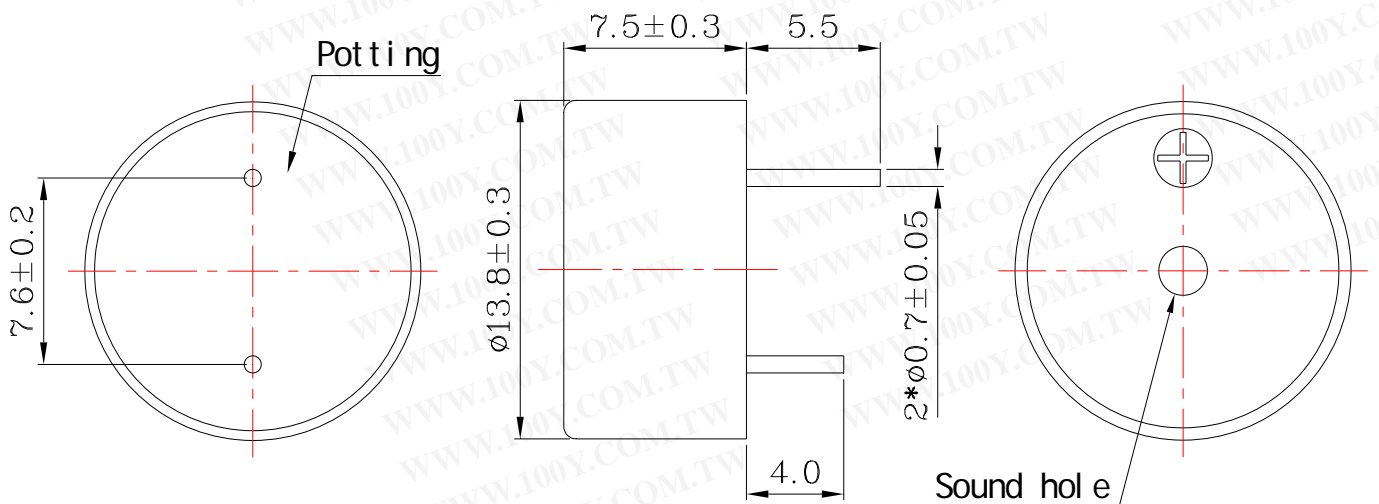

Tol : ± 0.5

Unit: mm

D. TESTING METHOD

Standard Measurement conditions

Temperature: $25 \pm 2^\circ\text{C}$ Humidity: 45-65%

勝特力材料 886-3-5753170
 勝特力电子(上海) 86-21-34970699
 勝特力电子(深圳) 86-755-83298787
[Http://www.100y.com.tw](http://www.100y.com.tw)

Acoustic Characteristics:

The oscillation frequency, current consumption and sound pressure are measured by the measuring instruments shown below

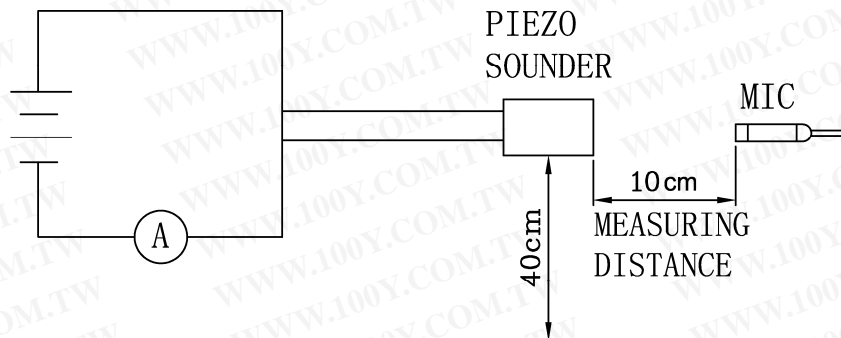

In the measuring test, buzzer is placed as follows:

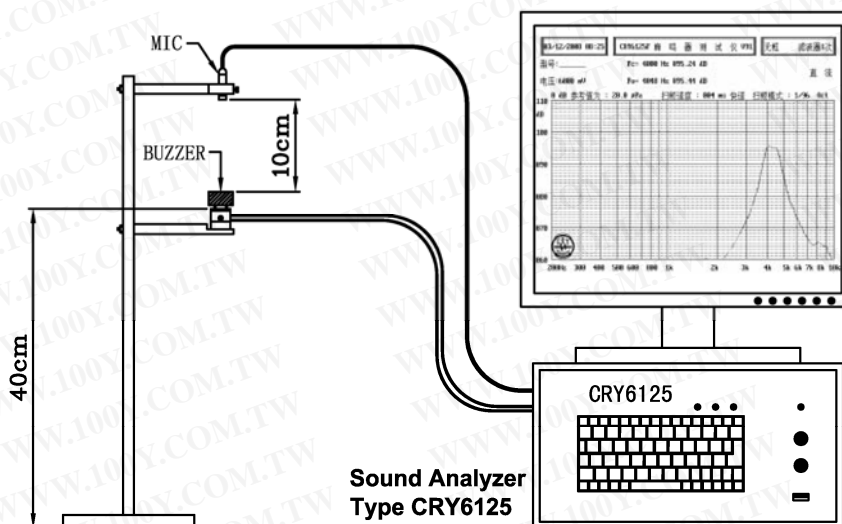

E. Typical Frequency Response Curve

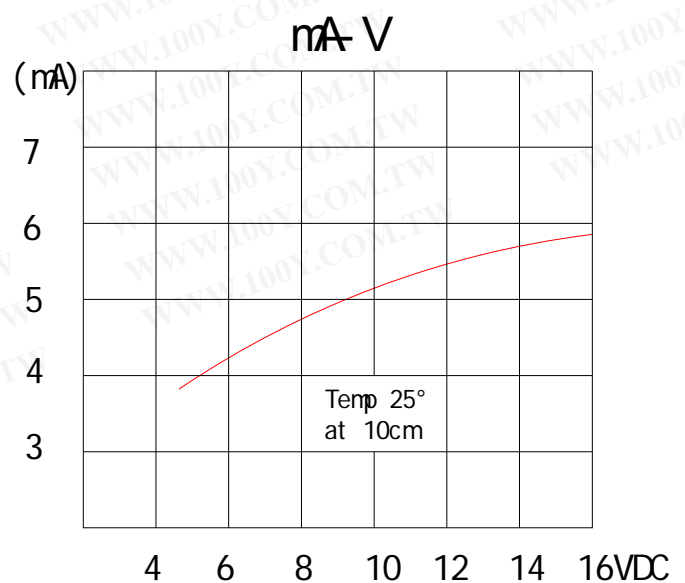
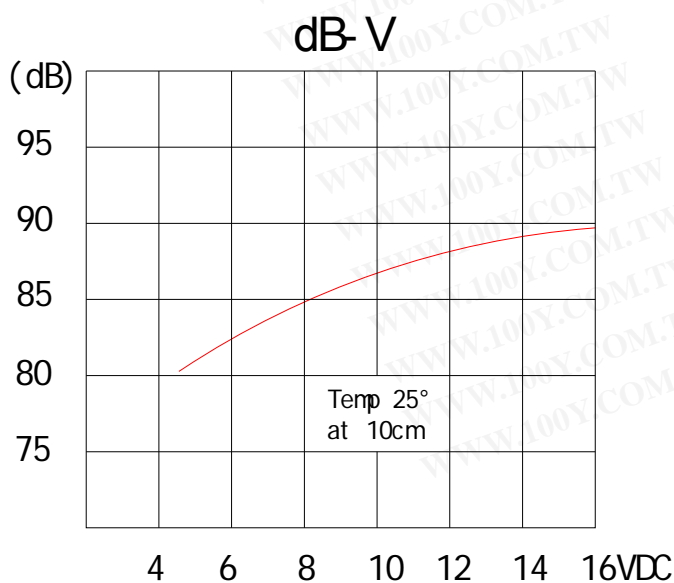

F. RELIABILITY TEST

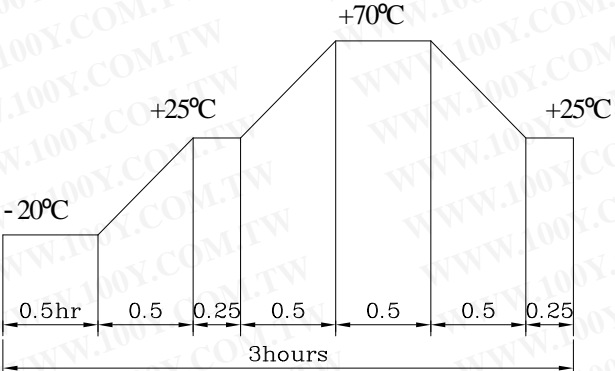
NO.	ITEM	TEST CONDITION AND REQUIREMENT
1	High Temperature Test (Storage)	After being placed in a chamber with 80±2°C for 96 hours and then being placed in normal condition for 2 hours. Allowable variation of SPL after test: ±10dB.
2	Low Temperature Test (Storage)	After being Placed in a chamber with -30±2°C for 96 hours and then being placed in normal condition for 2 hours. Allowable variation of SPL after test: ±10dB.
3	Humidity Test	After being Placed in a chamber with 90-95% R.H. at 40±2°C for 96 hours and then being placed in normal condition for 2 hours. Allowable variation of SPL after test: ±10dB.
4	Temperature Cycle Test	The part shall be subjected to 5 cycles. One cycle shall be consist of :  <p>The diagram shows a temperature cycle profile over a 3-hour period. It starts at -20°C for 0.5 hours, then ramps up to +25°C in 0.5 hours, holds at +25°C for 0.25 hours, ramps up to +70°C in 0.5 hours, holds at +70°C for 0.5 hours, ramps down to +25°C in 0.5 hours, holds at +25°C for 0.25 hours, and finally ramps down to -20°C in 0.5 hours. The total duration is 3 hours.</p> Allowable variation of SPL after test: ±10dB.
5	Drop Test	Drop on a hard wood board of 4cm thick, any directions ,6 times, at the height of 75cm . Allowable variation of SPL after test: ±10dB.
6	Vibration Test	After being applied vibration of amplitude of 1.5mmwith 10 to 55 Hz band of vibration frequency to each of 3 perpendicular directions for 2 hours . Allowable variation of SPL after test: ±10dB.
7	Solderability Test	Lead terminals are immersed in rosin for 5 seconds and then immersed in solder bath of +300±5°C for 3±1 seconds . 90% min. lead terminals shall be wet with solder (Except the edge of terminals).
8	Terminal Strength Pulling Test	The force of 9.8N(1.0kg) is applied to each terminal in axial direction for 10 seconds. No visible damage and cutting off.

TEST CONDITION.

Standard Test Condition	:	a) Temperature : +5 ~ +35°C	b) Humidity : 45-85%	c) Pressure : 860-1060mbar
一般测试条件	:	a) 温度 : +5 ~ +35°C	b) 湿度 : 45-85%	c) 气压 : 860-1060mbar
Judgment Test Condition	:	a) Temperature : +25 ± 2°C	b) Humidity : 60-70%	c) Pressure : 860-1060mbar
争议时测试条件	:	a) 温度 : +25 ± 2°C	b) 湿度 : 60-70%	c) 气压 : 860-1060mbar

勝特力材料 886-3-5753170
 勝特力电子(上海) 86-21-34970699
 勝特力电子(深圳) 86-755-83298787
[Http://www.100y.com.tw](http://www.100y.com.tw)

G. PACKING STANDARD

勝特力材料 886-3-5753170
 勝特力电子(上海) 86-21-34970699
 勝特力电子(深圳) 86-755-83298787
[Http://www.100y.com.tw](http://www.100y.com.tw)

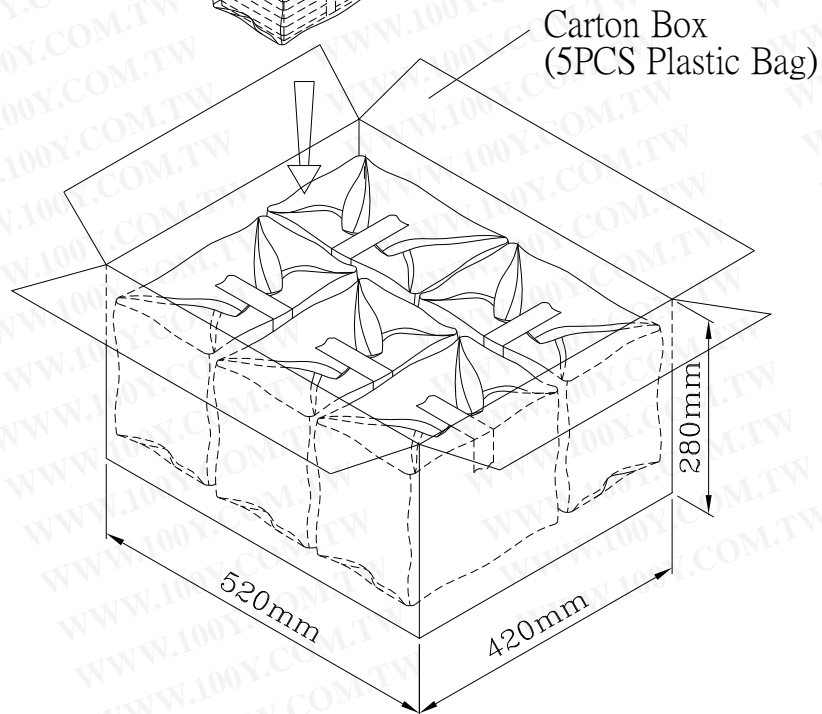
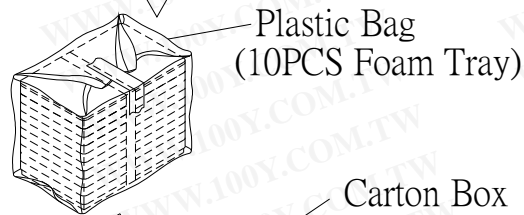
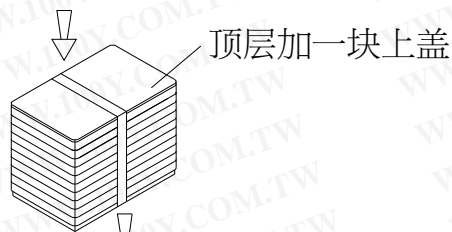
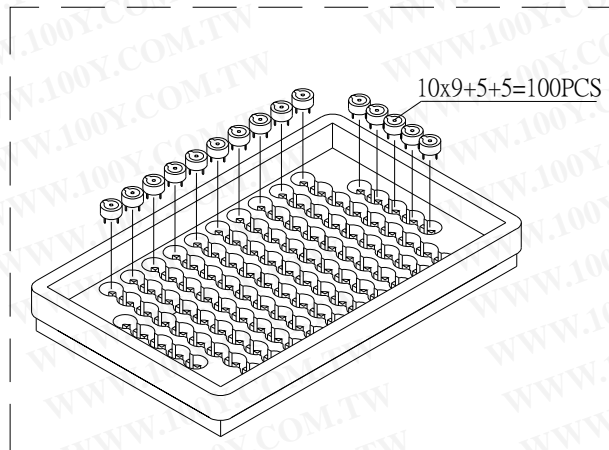

Foam Tray	240mmx160mmx30mm	1x100PCS=100PCS
Plastic Bag		10x100PCS=1000PCS
Carton Box	520mmx420mmx280mm	5x1000PCS=5,000PCS