

Inductors for power circuits  
Wound metal  
VLS-HBX series



# VLS3012HBX type



## FEATURES

- Magnetic shield type wound inductor for power circuits using a metallic magnetic material.
- High magnetic shield construction and compatible with high-density mounting.
- Larger current was achieved by the metallic magnetic material.

勝特力材料 886-3-5753170  
勝特力电子(上海) 86-21-34970699  
勝特力电子(深圳) 86-755-83298787  
[Http://www.100y.com.tw](http://www.100y.com.tw)

## APPLICATION

- HDD, SSD, DVC, DSC, mobile display panels, smart phones, tablet terminal, portable game devices, compact power supply modules, other
- Application guides: [Smart phones/tablets](#)

## PART NUMBER CONSTRUCTION

VLS	3012	HB	X	-	R33	N
Series name	LxWxH dimensions 3.0x3.0x1.2 mm	Internal code 1	Internal code 2		Inductance (μH)	Inductance tolerance

## CHARACTERISTICS SPECIFICATION TABLE

L (μH)	L measuring frequency (MHz)	DC resistance (Ω)max. (Ω)typ.	Rated current*				Part No.		
			Isat (A)max.	Itemp (A)max.	Isat (A)typ.	Itemp (A)typ.			
0.33	±30%	1	0.030	0.023	9.11	6.10	10.12	6.78	<a href="#">VLS3012HBX-R33N</a>
0.47	±20%	1	0.035	0.027	7.46	5.32	8.29	5.91	<a href="#">VLS3012HBX-R47M</a>
0.68	±20%	1	0.038	0.032	5.95	5.09	6.75	5.66	<a href="#">VLS3012HBX-R68M</a>
1.0	±20%	1	0.047	0.039	5.50	4.62	6.11	5.13	<a href="#">VLS3012HBX-1R0M</a>
1.5	±20%	1	0.067	0.056	4.41	3.77	4.90	4.19	<a href="#">VLS3012HBX-1R5M</a>
2.2	±20%	1	0.106	0.088	3.35	2.84	3.76	3.15	<a href="#">VLS3012HBX-2R2M</a>
3.3	±20%	1	0.150	0.130	2.82	2.37	3.22	2.63	<a href="#">VLS3012HBX-3R3M</a>
4.7	±20%	1	0.201	0.175	2.51	2.01	2.79	2.23	<a href="#">VLS3012HBX-4R7M</a>
6.8	±20%	1	0.285	0.248	1.98	1.66	2.24	1.84	<a href="#">VLS3012HBX-6R8M</a>
10	±20%	1	0.415	0.361	1.70	1.33	1.89	1.48	<a href="#">VLS3012HBX-100M</a>
15	±20%	1	0.636	0.553	1.37	1.11	1.52	1.23	<a href="#">VLS3012HBX-150M</a>
22	±20%	1	0.761	0.662	1.09	1.01	1.21	1.12	<a href="#">VLS3012HBX-220M</a>

\* Rated current: smaller value of either Isat or Itemp.

Isat: When based on the inductance change rate (30% below the initial L value)

Itemp: When based on the temperature increase (temperature increase of 40°C by self heating)

### Measurement equipment

Measurement item	Product No.	Manufacturer
L	4294A	Keysight Technologies
DC resistance	34420A	Hewlett-Packard
Rated current Isat	4285A+42841A+42842C	Keysight Technologies

\* Equivalent measurement equipment may be used.

## TEMPERATURE RANGE, INDIVIDUAL WEIGHT

Operating temperature range*	Storage temperature range**	Individual weight
-40 to 105 °C	-40 to 105 °C	53 mg

\* Operating temperature range includes self-temperature rise.

\*\* The storage temperature range is for after the assembly.

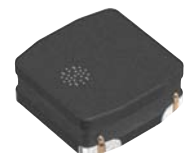

# VLS3012HBX type

## L FREQUENCY CHARACTERISTICS

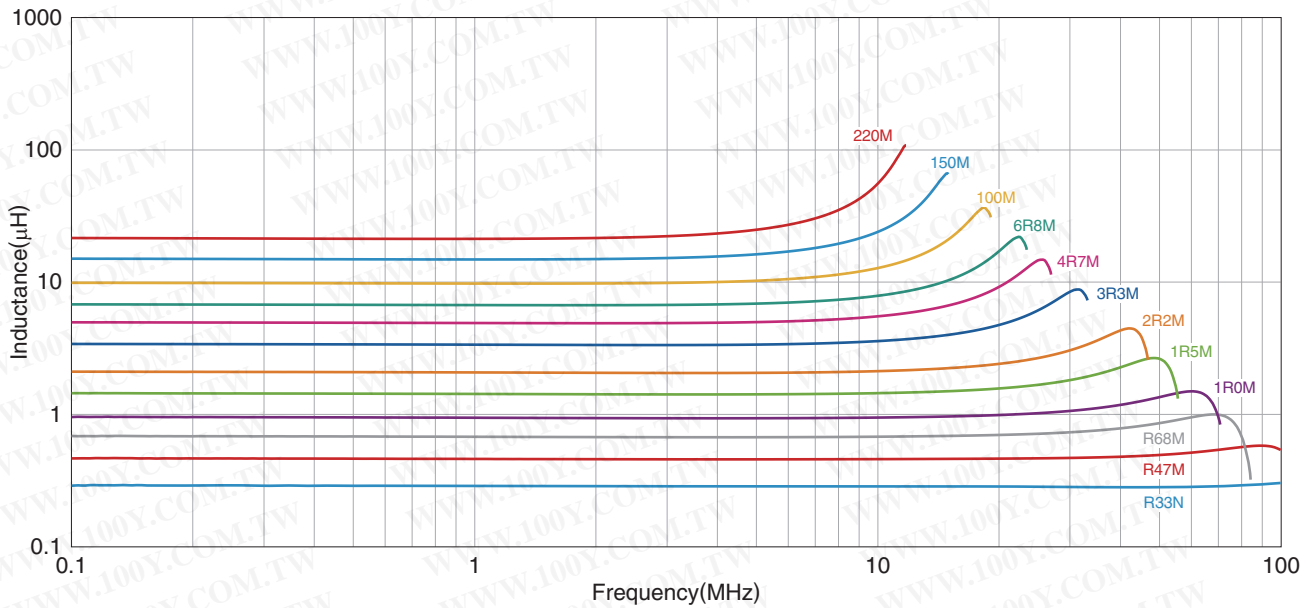

Measurement equipment

Product No.	Manufacturer
4294A	Keysight Technologies

\* Equivalent measurement equipment may be used.

## INDUCTANCE VS. DC BIAS CHARACTERISTICS

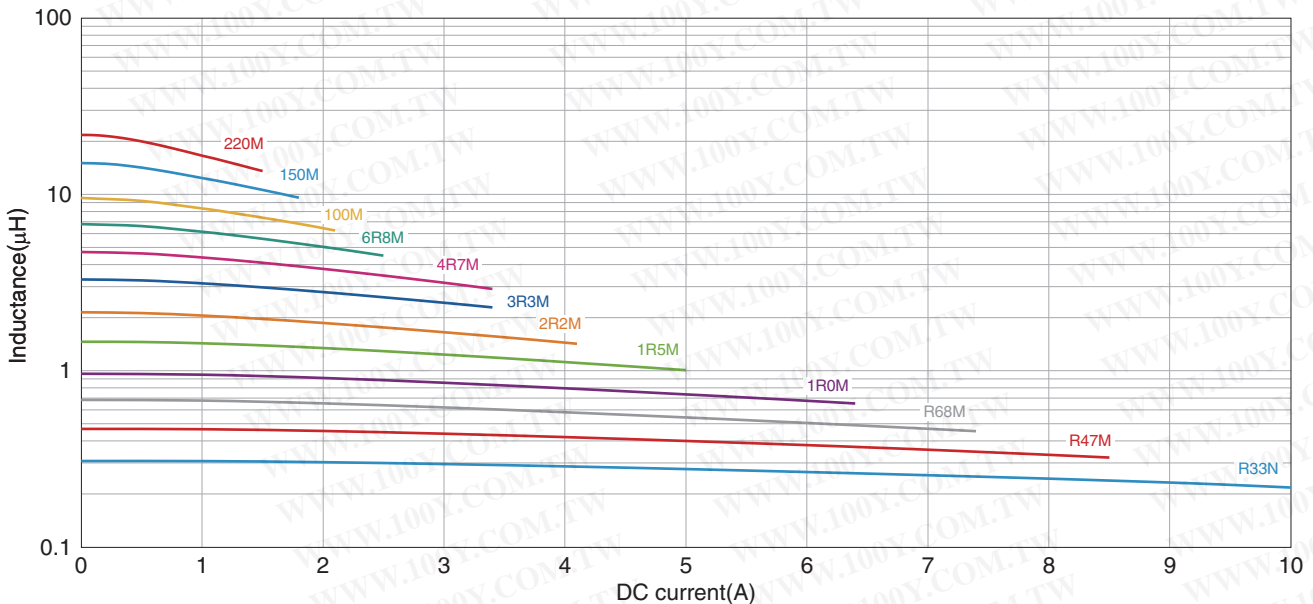

Measurement equipment

Product No.	Manufacturer
4285A+42841A+42842C	Keysight Technologies

\* Equivalent measurement equipment may be used.

# VLS3012HBX type

## SHAPE & DIMENSIONS

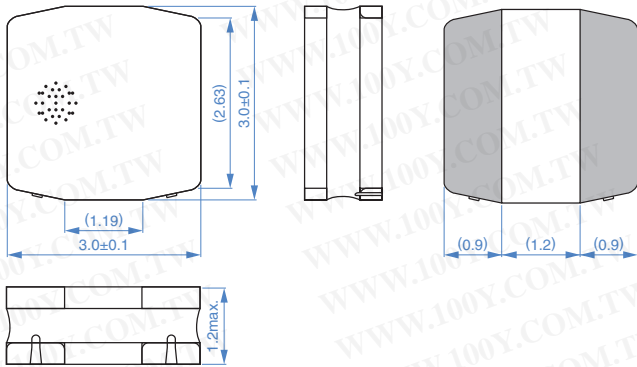

Dimensions in mm

## PACKAGING STYLE

### REEL DIMENSIONS

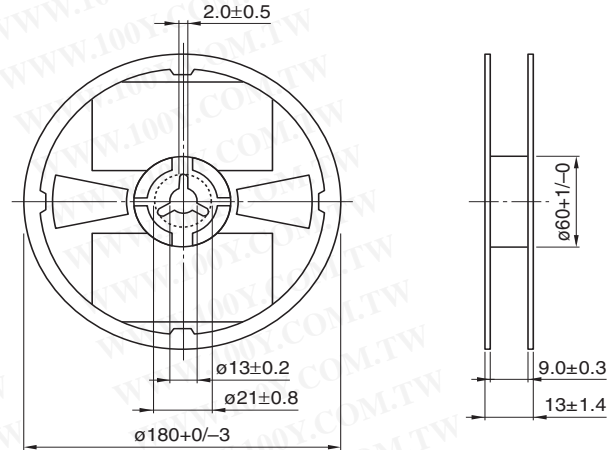

Dimensions in mm

## RECOMMENDED LAND PATTERN

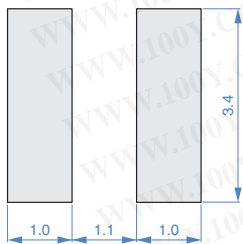

Dimensions in mm

### TAPE DIMENSIONS

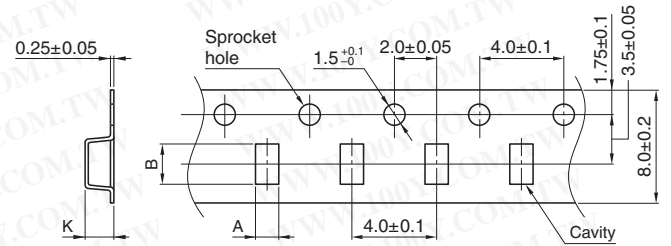

Dimensions in mm

Type	A	B	K
VLS3012HBX	3.20±0.05	3.20±0.05	1.35±0.1

## RECOMMENDED REFLOW PROFILE

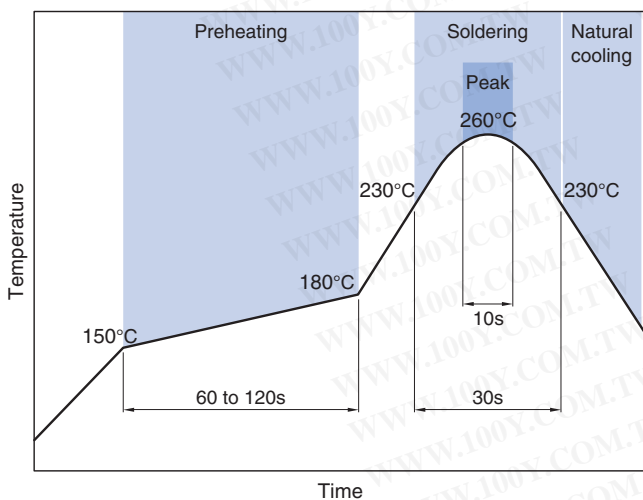

### PACKAGE QUANTITY

Package quantity	2000pcs/reel
------------------	--------------

勝特力材料 886-3-5753170  
 勝特力电子(上海) 86-21-34970699  
 勝特力电子(深圳) 86-755-83298787  
[Http://www.100y.com.tw](http://www.100y.com.tw)