

Model No.	POS.1	POS.2
7MD7	ON	MOM
Term. Comm.	1-3,4-6	1-2,4-5
SCHEMATIC		
	1 Comm. 2 NO 3 NC 4 Comm. 5 NO 6 NC	1 Comm. 2 NO 3 NC 4 Comm. 5 NO 6 NC

SWITCH FUNCTION

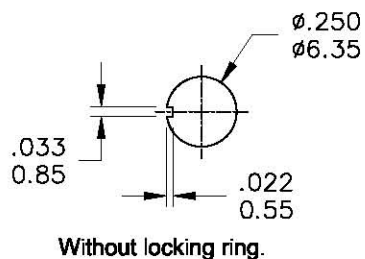

PANEL MOUNTING

SPECIFICATIONS

MECHANICAL LIFE: 50,000 make-and-break cycles.
CONTACT RESISTANCE: 20mΩ max. initial @ 2-4VDC
 100mA for both silver and gold plated contacts.
INSULATION RESISTANCE: 1,000MΩ min.
DIELECTRIC STRENGTH: 1,000 V RMS@sea level.
OPERATING TEMPERATURE: -30°C to 85°C.

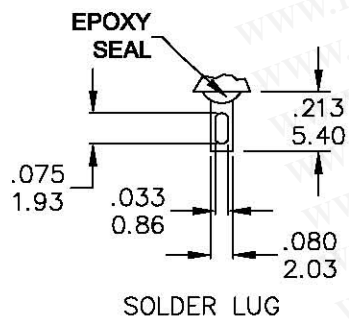

SOLDER LUG

MATERIALS

CASE: Dially phthalate (DAP) (UL94v-0).
PLUNGER: Glass filled Nylon or Glass filled polyester.
BUSHING: Brass, nickel plated.
HOUSING: Stainless Steel.
CONTACT: Silver or gold plated.
RoHS: 2002/95/EC

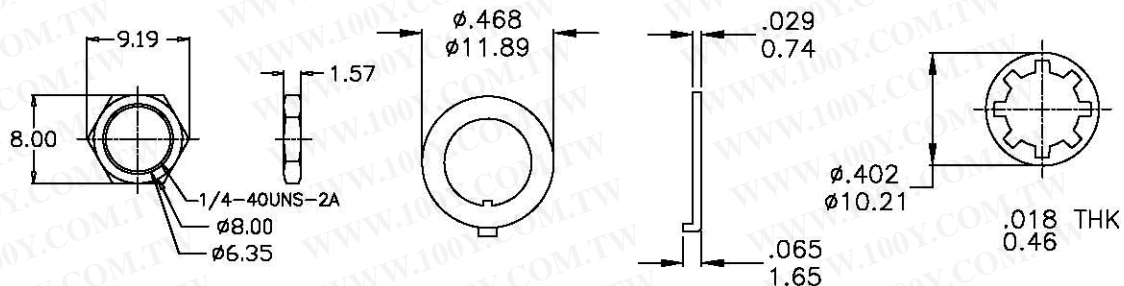

	CONTACT MATERIAL	TERMINATION RATING	RATINGS
Q	Silver	Q = Silver	3 Amps @120 VAC or 28 VDC 1 Amp @250VAC
S		S = Silver,pure-tin	
C	Gold over Silver	C = Gold over silver	0.4 Volt-Amps(VA) max. @20V max. (AC or DC)
K		K = Gold over silver,pure-tin	
R	Gold	R = Gold	
G		G = Gold,pure-tin	

	符號	原尺寸	修改後尺寸	變更日期
1	Ⓐ		圖面重新整理	OCT-17-2008
2	Ⓑ			
3	Ⓒ			
4	Ⓓ			
5	Ⓔ			

勝特力材料 886-3-5753170
 勝特力电子(上海) 86-21-34970699
 勝特力电子(深圳) 86-755-83298787
[Http://www.100y.com.tw](http://www.100y.com.tw)

SCALE (比例): 3 : 2

TOLERANCE (公差):
 0.00 mm ± 0.25mm
 0.0 mm ± 0.40mm
ANGULAR : ± 5°
FILE NAME : 7MDP0104

TITLE 圖名	Sanp-Acting Pushbutton Switches			SIZE 圖紙	A4
DWG NO. 圖號				UNIT 單位	inch mm
REV. 版本	B	DATE 日期	FEB - 1 - 2007	SHEET 張數	1 of 1
CHECKED BY 審核	RICHARD		DRAWN BY 製圖	FION	