

Description

Electronic circuit breaker type ESS20 is designed to ensure **selective** disconnection of individual loads in systems which are powered by a DC 24 V switch-mode power supply.

DC 24 V power supplies, which are widely used in industry today, will shut down the output in the event of an overload with the result that one faulty load in the system can lead to complete disconnection of all loads. As well as an unidentified failure this also means stoppage of the whole system.

Through **selective** disconnection the ESS20 responds much faster to overload or short circuit conditions than the switch-mode power supply. This is achieved by a combination of active current limitation and well-proven circuit breaker technology including physical isolation. The ESS20 limits the highest possible current to 1.8 times the set rated current of the circuit breaker. Thus it is possible to switch on even capacitive loads or lamp loads, but they are disconnected only in the event of an overload or short circuit.

For optimal adjustment to the application conditions the current rating of the ESS20 can be selected by a switch (3 A or 6 A). Failure and status indication are provided by a bicolour LED and an integral signal contact.

The ESS20 features a width of only 12.5 mm and can be plugged into the E-T-A power distribution socket Module 17plus, ensuring ease of installation and saving space in control cabinets.

Features

- Selective load protection with physical isolation in the event of a fault
- All types of loads can be connected (DC motors etc. on request)
- Active current limitation (1.8 times rated current) for safe connection of capacitive loads and on overload/short circuit
- Electronic trip characteristic
- One unit for two current ratings: 3 A and 6 A (selectable)
- Manual ON/OFF button (push-push actuation)
- Clear status and failure indication
- Width per unit only 12.5 mm
- Plug-in mounting utilising power distribution system Module 17plus

Approvals

VDE, UL approval pending



Technical data ($T_{\text{ambient}} = 25^{\circ}\text{C}$, operating voltage $U_B = \text{DC } 24 \text{ V}$)

Operating data

Operating voltage U_B	DC 24 V (18 ... 32 V)
Current rating I_N	3 A or 6 A (selected by means of a switch)
Power consumption	typically 13 mA
Trip current (bimetal)	typ. 1A (only in the event of a failure, before physical isolation)
Status indication by means of	bicolour LED: GREEN: unit is ON, power-MOSFET is switched on ORANGE: in the event of overload or short circuit until physical isolation LED not lighted: push button in OFF position potential-free signal contact (change-over contact) OFF-position of push button

Reverse polarity protection of U_B	internal bimetal (fail-safe element) trips, push button moves into OFF position
--------------------------------------	---

Load circuit

Load output	Power-MOSFET switching output (high side switch)
Max. data of load with side-by-side mounting	DC 24 V / 6 A (resistive, inductive, capacitive, lamp load) 6A at $T_{\text{amb}} = +40^{\circ}\text{C}$ and 100% ON duty 5A at $T_{\text{amb}} = +50^{\circ}\text{C}$ and 100% ON duty
Voltage drop at I_N	typically 130 mV / 3 A typically 260 mV / 6 A
Overload disconnection	typically $1.1 \times I_N$ ($1.05 \dots 1.25 \times I_N$)
Short-circuit current I_K	typically $1.8 \times I_N$ (max. $2 \times I_N$) / active current limitation
Trip time for physical isolation	see time/current characteristics typ. 5 sec at $I_{\text{load}} > 1.1 \times I_N$
Trip time for electronic disconnection	typ. 5 sec ... 100 ms at $I_{\text{load}} > 1.8 \times I_N$
Temperature disconnection	internal temperature monitoring with physical isolation
Low voltage monitoring load output	ON at $U_B > 15\text{V}$ OFF at $U_B < 8 \text{ V}$
Starting delay t_{start}	typically 0.3 sec after every switch-on and after applying U_B
Disconnection of load circuit	single pole (switch contact) - by push-push actuation of the blue push button - upon electronic fault disconnection (overload, short circuit) - with reverse polarity
Free-wheeling circuit	external free-wheeling diode recommended with inductive load

Several load outputs must not be connected in parallel.

Technical data ($T_{\text{ambient}} = 25^{\circ}\text{C}$, operating voltage $U_B = \text{DC } 24 \text{ V}$)

Fault indication, signal output

Fault indications	potential-free auxiliary contact change-over (SC-SO / SC-SI) simultaneously with physical isolation max. DC 30 V / 0.5 A, min. 10 V / 10 mA
Signal output	blue push button in ON position: signal contact SC-SO is closed (SC-SI is open) blue push button in OFF position: signal contact SC-SO is open (SC-SI is closed)
Visual indication	LED lighted after typ. 50 ms in ORANGE (until physical isolation)

General data

Ambient temperature	0...+50 °C (without condensation, see EN 60204-1)
Storage temperature	-20...+70 °C
Backup fuse for ESS20	not required because of the integral redundant fail-safe element (thermal E-T-A circuit breaker) in Vorb.)
Blade terminals	6.3 mm to DIN 46244-A6, 3-0,8
Housing material	plastics material
Mounting of housing	plug-in mounting utilising power distribution system Module 17plus
Vibration	3 g, test to IEC 68-2-6 test Fc
Degree of protection	Housing: IP 20 DIN 40050, Terminals: IP 00 DIN 40050
EMC (EMC directive, CE logo)	Emission: EN 50081-1 Susceptibility: EN 61000-6-2
Insulation co-ordination (IEC 60934)	0.5 kV/2 re-inforced insulation in operating area
Dielectric strength (see dimensions)	operating area test voltage AC 1000 V installation area test voltage AC 500 V load circuit-signal contact test voltage AC 500 V
Insulation resistance (OFF condition)	>100 M Ω (DC 500 V) [LINE (+) – LOAD (+)]
Dimensions (W x H x D)	12.5 x 105 x 60 mm
Mass	60 g

Ordering information

Type No.

ESS20 Electronic Circuit Breaker for DC 24 V applications

Version

00 standard

Control input

0 without signal contact

3 with signal contact (changeover contact)

Input voltage

DC 24 V rated voltage DC 24 V

Current rating

3 A/6 A selectable (switch)

ESS20 - 00 3 - DC 24 V - 3 A/6 A ordering example (recommended type)

Basic circuit diagram

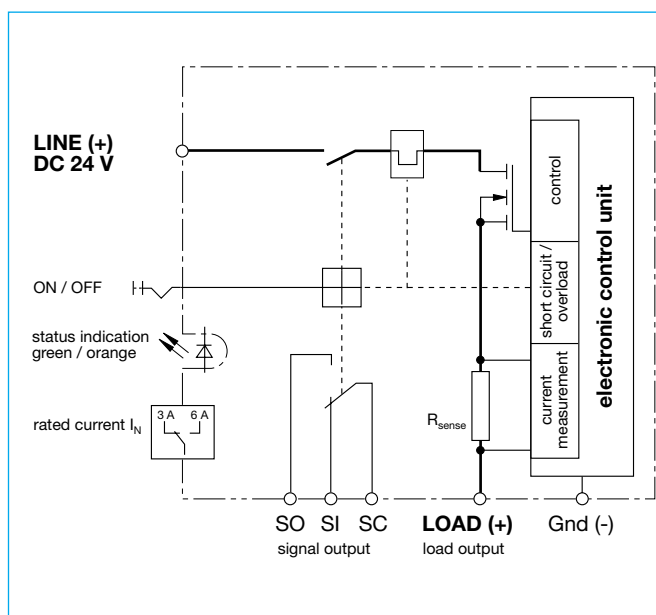

Time/Current characteristic curve

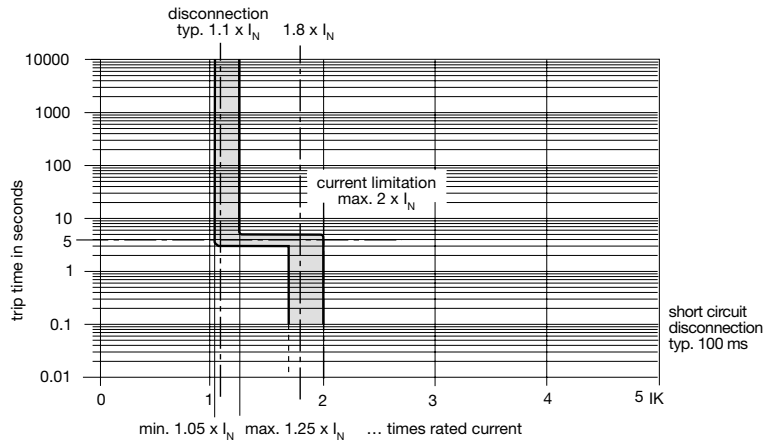

- The trip time is typically 5 s in the range between 1.1 and 1.8 x I_N.
- Without the current limitation activated at typ. 1.8 x I_N a considerably higher overload current would flow in the event of an overload or short circuit.
- Electronic current limitation starts at typ. 1.8 x I_N (max. 2 x I_N) which means that under all overload conditions (independent of the power supply and the resistance of the load circuit) the max. overload until disconnection will not exceed two times the current rating. Trip time is between 100 ms (short circuit current I_k) and 5 sec (at overload with high line attenuation).
- After detection of an overload or short circuit the LED changes colour from GREEN to ORANGE. The LED will no longer be lighted after the circuit breaker has tripped.
- Resetting the circuit breaker is not possible before the integral bimetal has cooled down (approx. 30 sec).

Terminal wiring diagram

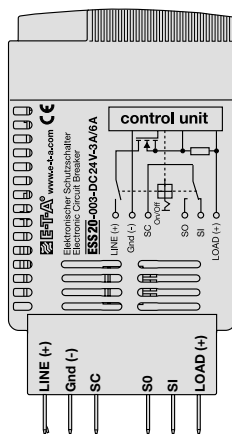

This is a metric design and millimeter dimensions take precedence ($\frac{\text{mm}}{\text{inch}}$)

All dimensions without tolerances are for reference only. In the interest of improved design, performance and cost effectiveness the right to make changes in these specifications without notice is reserved. Product markings may not be exactly as the ordering codes. Errors and omissions excepted.

Dimensions

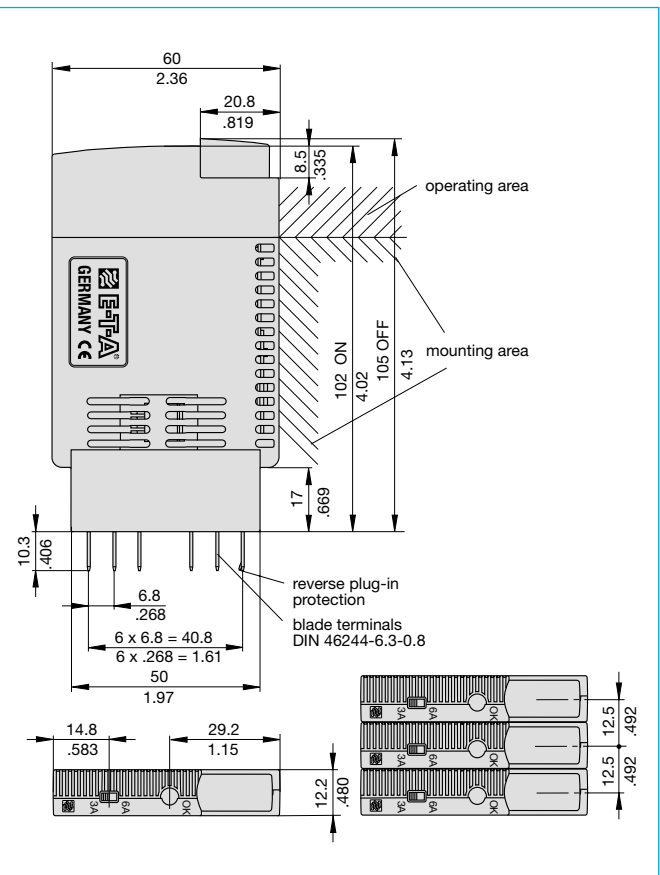

Accessories for ESS20



Description

Module 17plus is a power distribution system for use with electronic circuit breaker ESS20.

Each module accommodates two breakers with an individual housing width of only 12.5 mm and fits onto all industry standard mounting rails.

The two-way modules can be interconnected to provide as many ways as required with a terminal block fitted at each end for connection of signalling circuits. A distribution busbar can be fitted on the supply side of the modules (positive pole) though each pole of multipole circuit breakers must be individually connected.

Electrical connections are by means of spring-loaded terminals. The reference potential for the ESS20 (GND pin 11) is also looped through and connected to the terminals at the sides. The ESS20 has an integral signal contact (change-over contact). The contact SC-SO is used for group fault signalisation. For this purpose the contacts for signalisation are connected in series in the Module 17plus and are connected to the terminal blocks via two terminals (13,14). It is possible with a test probe to contact the series connection in each module and detect possible interruptions.

All internal wirings for the ground potential and the group signal are established by the modular mounting of the individual Modules 17plus.

The integral make contact of the ESS20 (SC-SI) can be tapped at terminal 12 of the relevant channel (individual signalisation).

Technical data

Connection	Spring-loaded terminals for solid conductors and stranded cables with and without wire end ferrules. Please use appropriate screw driver size (SD) for removing the spring loaded terminals.
LINE feed (1)	spring-loaded terminals for 0.5-6 mm ² (AWG 10), SD 2 (0.8x4.0)
LOAD output (2)	spring-loaded terminals for 0.25-4 mm ² (AWG 12), SD 1 (0.6x3.5)
Reference potential GND/ group signal terminals (11 or 13, 14):	spring-loaded terminals for 0.25-2.5 mm ² (AWG 14), SD 1 (0.6x3.5)
individual signal terminal (12)	spring-loaded terminal for 0.25-1.5 mm ² (AWG 16), SD 0 (0.4x2.5)

Test probe for testing the group signal for line interruption: $\leq 2 \text{ mm } \varnothing$

Voltage rating
(without ESS20): AC 433 V; DC 65 V

Current rating (without ESS20)	
LINE feed (1)	50 A
LOAD output (2)	25 A
Reference potential GND (11)	10 A
Individual signal (12)	1 A (with ESS20: 0,5 A)
Group signal /(13-14)	1 A (with ESS20: 0,5 A)

Internal resistance values (without ESS20)	
LINE-LOAD (1-2)	$\leq 5 \text{ m}\Omega$
Group signal (13-14) per module	$\leq 8 \text{ m}\Omega$ per pole +5 m Ω for each additional module

Busbar for power distribution insulated busbar (blue or red):	I_{max}	32 A
non-insulated busbar:	I_{max}	50 A
(The non-insulated busbar, too, meets brush contact safety standards when fitted.)		

Dielectric strength of Module 17plus (without ESS20)	
between main circuits (without busbar):	1,500 V
main circuit to auxiliary circuit:	1,500 V
between auxiliary circuits:	1,500 V

Mass: Module 17plus (middle part)	approx. 85 g
terminal blocks (pair)	approx. 30 g

Ordering information

17PLUS-Q02-00	Module 17plus, middle part, two-way
17PLUS-Q00-LR-EES	one each left- and right-side terminal block for ESS20
17PLUS-QA0-LR-EES	one each left- and right-side terminal block with screw terminal for busbar for ESS20

Dimensions

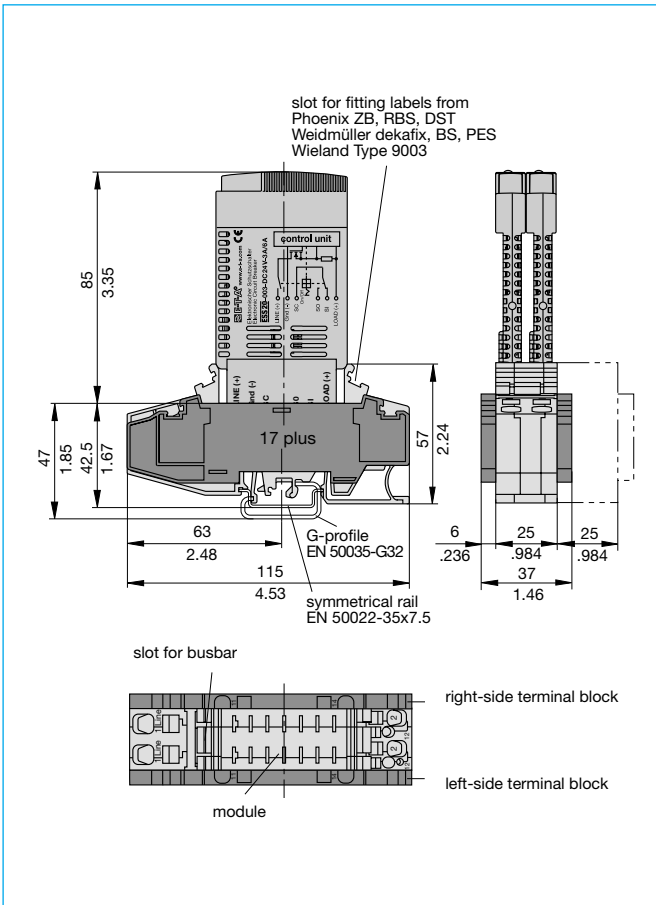

Installation example

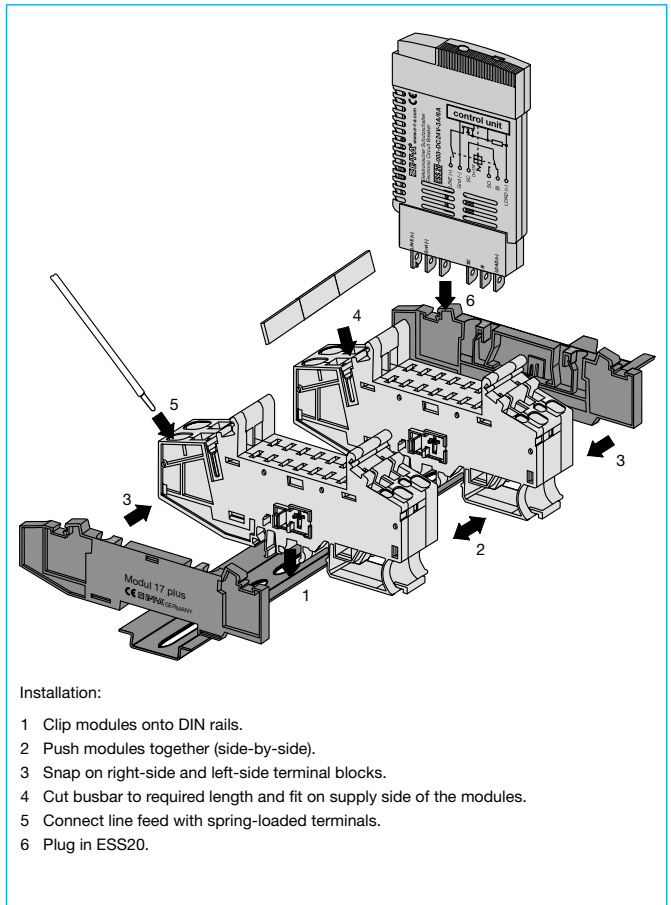

Connection diagram

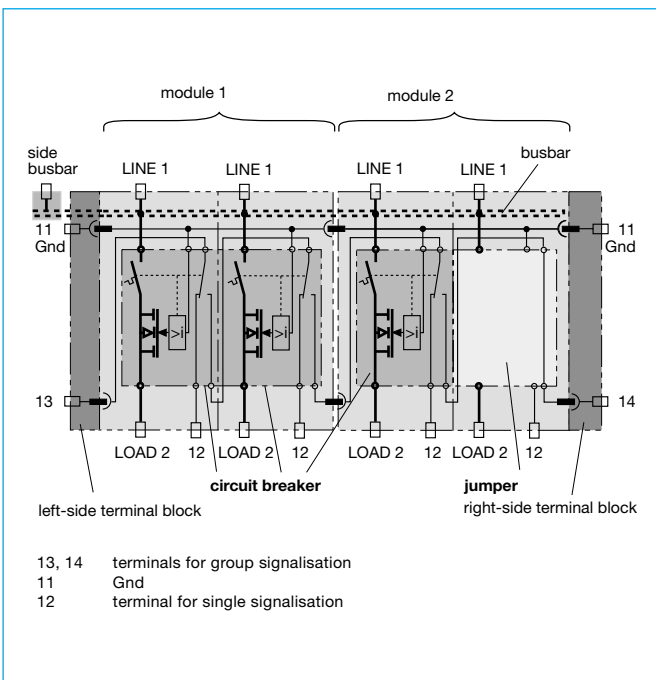

Pin configuration, fitted with ESS20

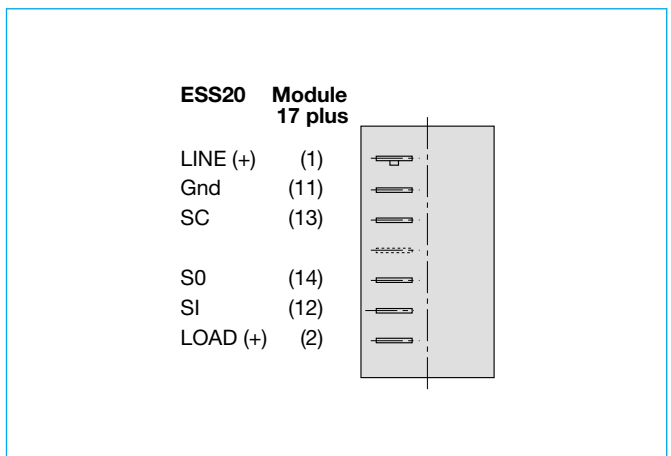

This is a metric design and millimeter dimensions take precedence ($\frac{\text{mm}}{\text{inch}}$)

Accessories

Busbar 32 A

- X 222 005 01 blue insulation, 500 mm/19.68 in.
- X 222 005 02 red insulation, 500 mm/19.68 in.
- X 222 005 03 grey insulation, 500 mm/19.68 in.

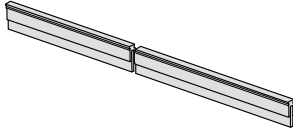

Busbar 50 A

- Y 307 016 01 non-insulated, 500 mm/19.68 in.

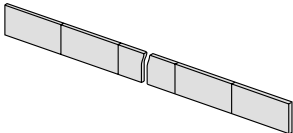

Busbar 50 A

- for busbar connection by means of terminal 17plus-QA0-LR
- Y 307 016 11 non-insulated, 500 mm/19.68 in.

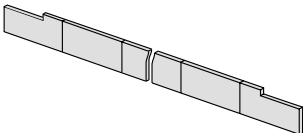

End bracket

- X 222 004 01

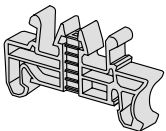

Screw terminal for busbar

- X 211 156 01 non insulated

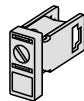

Jumper

- X 222 066 01

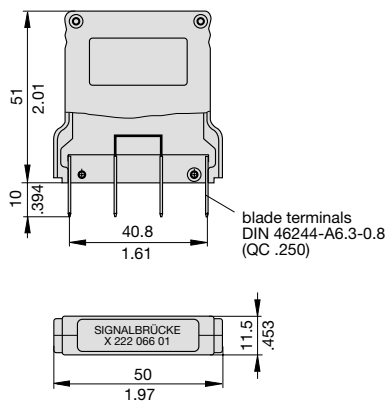

This is a metric design and millimeter dimensions take precedence ($\frac{\text{mm}}{\text{inch}}$)

All dimensions without tolerances are for reference only. In the interest of improved design, performance and cost effectiveness the right to make changes in these specifications without notice is reserved. Product markings may not be exactly as the ordering codes. Errors and omissions excepted.