

SPECIFICATIONS:

- 1.Contact Rating: 4A AC125V / 2A AC250V.
- 2.Electrical Life: 20,000 cycles.
- 3.Contact Resistance: 50m-ohms max (initial).
- 4.Insulation Resistance: 100M-ohms min @ 500VDC.
- 5.Dielectric Strength: 1,500V for 1 minute.
- 6.Switching Circuit: ON-ON.
- 7.Panel Thickness: 3.0mm Max.
- 8.Operating Temperature: -20°C to +65°C.

REMARK:

ON-OFF function can be made by either manual trimming or not wiring the one end terminal.

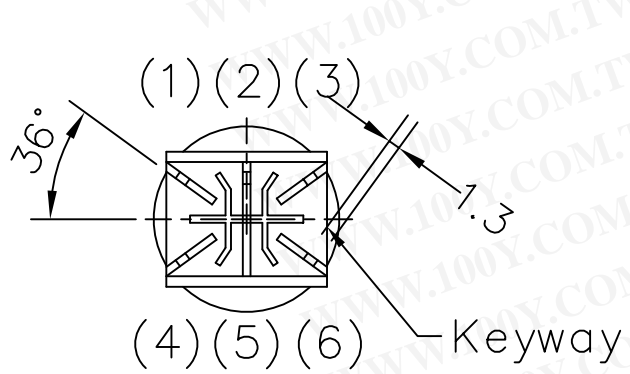

Panel Thickness :
3.0mm Max.

勝特力材料 886-3-5753170
 勝特力电子(上海) 86-21-34970699
 勝特力电子(深圳) 86-755-83298787
[Http://www.100y.com.tw](http://www.100y.com.tw)

ITEM NO. 料號	FS-DP1-PCBDM2QE
----------------	-----------------

THESE DRAWINGS AND SPECIFICATIONS ARE THE PROPERTY OF TAIWAY ELECTRONICS COMPONENTS LTD. AND SHALL NOT BE REPRODUCED COPIED OR USED IN ANY MANNER WITHOUT THE PRIOR WRITTEN CONSENT OF TAIWAY ELECTRONICS COMPONENTS LTD.			
UNLESS OTHERWISE SPECIFIED DIMENSIONS ARE IN MILLIMETERS ANGULAR TOLERANCE: ±1.0°		USED 用途 FS	
DIMENSIONS TOLERANCE		APPD. 審核 Amy 2011/09/02	
0.00 TO 10.00mm	±0.20mm	FINISH 處理	
10.01 TO 20.00mm	±0.25mm	CHKD. 校對 Amy 2011/09/02	
20.01 TO 30.00mm	±0.30mm	SCALE 比例 /	UNIT 單位 mm
30.01	±0.40mm	DR. 製圖 Amy 2011/09/02	
MATERIAL		TITLE 名稱 Foot Switch	
		DWG NO. 圖號 FS-DP1-PCBDM2QE	SIZE 圖紙 A4
		FILE NAME 檔案名稱 FS-DP1-PCBDM2QE.DWG	SHEET 張 1 / 1
		REV. 更改	1