

勝特力材料 886-3-5753170
勝特力电子(上海) 86-21-34970699
勝特力电子(深圳) 86-755-83298787
[Http://www.100y.com.tw](http://www.100y.com.tw)

Issued November 2009

12485

DATA SHEET



NF MCCB

Based on Mitsubishi MCCB Datasheet

Detailed Specifications

Molded-Case Circuit Breakers





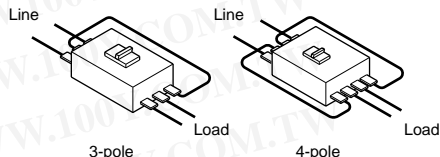

Series	C series		S series		C series		S series		H series		C series	
Frame Size	30		32		63		63		63		125	
Photo												
Type name	NF30-CS		NF32-SW		NF63-CW		NF63-SW		NF63-HW		NF125-CW	
Rated current In (Amp.)	3 5 10 15 20 30		3 4 6 10 16 20 25 32		3 4 6 10 16 20 25 32 40 50 63		3 4 6 10 16 20 25 32 40 50 63		10 16 20 25 32 40 50 63		50 63 80 100 125	
Rated ambient temperature (°C)	30		40		40		40		40		40	
Number of poles	2 3		2 3		2 3		2 3 4		2 3 4		2 3	
Rated insulation voltage Ui (V)	500		600		600		600		690		600	
Rated short-circuit breaking capacities (kA)	IEC60947-2 (Icu/Ics)	AC (50/60Hz)	690V	-	-	-	-	-	-	2.5/1	-	-
			525V	-	-	-	-	-	-	-	-	-
			500V	-	2.5/1	2.5/1	2.5/1	7.5/4	7.5/4	7.5/4	7.5/4	7.5/4
			440V	-	2.5/1	2.5/1	2.5/1	7.5/4	7.5/4	10/5	10/5	10/5
			415V	1.5/1.5	2.5/1	2.5/1	2.5/1	7.5/4	7.5/4	10/5	10/5	10/5
			400V	-	5/2	5/2	5/2	7.5/4	7.5/4	10/5	10/5	10/5
			380V	1.5/1.5	5/2	5/2	5/2	7.5/4	7.5/4	10/5	10/5	10/5
			230V	2.5/2 (240V)	7.5/4	7.5/4	7.5/4	15/8	15/8	25/13	25/13	30/15
DC	250V	-	2.5/1 *4	-	2.5/1 *4	-	7.5/4 *4	-	7.5/4 *4	-	7.5/4 *1	
	300V	-	-	-	-	-	-	-	-	-	-	
Suitability for isolation	-		●		●		●		●		●	
Utilization category	A		A		A		A		A		A	
Reverse connection (terminals unmarked)	-		●		●		●		●		●	
Rated impulse withstand voltage Uimp (kV)	4		6		6		6		6		8	
Pollution degree	2		2		2		2		2		3	
Number of operating cycles	without current	440V-In/2	10,000		10,000		10,000		15,000		10,000	
		440V-In	6,000 (415V)		6,000		6,000		15,000		6,000	
		690V-In/2	-		-		-		-		-	
		690V-In	-		-		-		-		-	
with current	440V-In/2	6,000 (415V)		6,000		6,000		8,000		8,000		
	440V-In	-		-		-		-		-		
	690V-In/2	-		-		-		-		-		
	690V-In	-		-		-		-		-		
Overall dimensions (mm)		a	45	67.5	50	75	50	75	100	50	75	100
		b	96		130		130		130		130	
		c	52		68		68		68		68	
		ca	67		90		90		90		90	
Mass of front-face type (kg)	0.25	0.35		0.4	0.55		0.45	0.6		0.45	0.6	
	0.7	0.7		0.7	0.7		0.7	0.7		0.7	0.9	
Installation and connections	Fixed	Front	Screw terminal	●	●	●	●	●	●	●	●	●
			Solderless (box) terminal (SL)	-	-	-	-	-	-	-	-	-
			Busbar terminal	-	-	-	-	-	-	-	-	-
		Rear	(B)	●	●	●	●	●	●	●	●	●
		Plug-in	Rear	(PM)	-	-	-	-	-	-	-	-
IEC 35mm rail	Rear/front IP20	(PM-IP)	-	-	-	-	-	-	-	-	-	
	Mounting hook (option)	-	●	●	●	●	●	●	●	●	●	
Adapter (option)	-	-	●	●	●	●	●	●	●	●	●	
	-	-	●	●	●	●	●	●	●	●	●	
Cassette-type accessories (option) *5	Alarm switch	(AL)	●	●	●	●	●	●	●	●	●	
	Auxiliary switch	(AX)	●	●	●	●	●	●	●	●	●	
	Shunt trip	(SHT)	-	●	●	●	●	●	●	●	●	
	Undervoltage trip (UVT)	Non-Synchronous Closing (UVT-N)	-	●	●	●	●	●	●	●	●	
		Synchronous Closing (UVT-S)	-	-	-	-	-	-	-	-	-	
Accessorie's connection (option)	with Lead-wire terminal block	(SLT)	●	●	●	●	●	●	●	●	●	
	with Internal terminal type	(INT)	-	-	-	-	-	-	-	-	-	
	with Flying leads	-	●	●	●	●	●	●	●	●	●	
Built-in accessories (option)	Pre-alarm (contact output) *3	(PAL)	-	-	-	-	-	-	-	-	-	
	Overcurrent trip alarm *3	(OAL)	-	-	-	-	-	-	-	-	-	
	Cylinder key lock	[Available soon]	-	-	-	-	-	-	-	-	-	
External accessories (option)	Enclosure	Dustproof	(S)	●	●	●	●	●	●	●	●	●
		(I)	-	-	-	-	-	-	-	-	-	
		Waterproof	(W)	-	-	●	-	●	-	●	-	●
	Electrical operation device	(MD)	-	-	-	-	-	-	-	-	-	-
		(MI)	-	●	●	●	●	●	●	●	●	●
		(HL)	●	●	●	●	●	●	●	●	●	
	Handle lock device	Handle lock	(HL-S)	-	●	●	●	●	●	●	●	●
		(LC)	●	●	●	●	●	●	●	●	●	
	External operating handle	Door mounting	(V)	-	-	●	-	●	-	●	-	●
		(S)	-	-	●	-	●	-	●	-	●	
		Mounted on breaker	(R)	-	-	-	-	-	-	-	-	
	Insulating barrier	Between phase	(BA-F)	-	●	●	●	●	●	●	●	●
		To ground	(BA-G)	-	●	●	●	●	●	●	●	
		Large	(TC-L)	●	●	●	●	●	●	●	●	
	Terminal cover	Small	(TC-S)	●	●	●	●	●	●	●	●	●
Transparent		(TTC)	●	●	●	●	●	●	●	●		
for rear connection		(BTC)	●	●	●	●	●	●	●	●		
for plug-in		(PTC)	-	-	-	-	-	-	-	-		
Marine approval	[Available soon]	L/R	●	●	●	●	●	●	●	●	●	
		G/L	-	-	-	-	-	-	-	-		
		BV	●	●	●	●	●	●	●	●		
		DNV	●	●	●	●	●	●	●	●		
		ABS	●	●	●	●	●	●	●	●		
Automatic tripping device	Hydraulic-magnetic		Hydraulic-magnetic		Hydraulic-magnetic		Hydraulic-magnetic		Hydraulic-magnetic		Thermal-magnetic	
Trip button	-		Equipped		Equipped		Equipped		Equipped		Equipped	

- Notes *1: Use two poles in the case of three-pole or four-pole products.
In addition, wiring as shown to the right allows the three poles to be used for up to 400V DC and the four poles to be used for up to 500V DC.
- *2: Use two poles in the case of three-pole or four-pole products.
In addition, wiring as shown to the right allows the three poles to be used for up to 500V DC and the four poles to be used for up to 600V DC.
- *3: Both PAL and OAL is not available. Only one specified.
- *4: Specify if for DC use.
- *5: Cassette-type accessories are not suitable for NF30-CS.



Detailed Specifications

Molded-Case Circuit Breakers

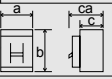
Series		S series						H series								
Frame Size		160						160								
Photo																
Type name		NF160-SW		NF160-SGW RT		NF160-SGW RE		NF160-HW		NF160-HGW RT		NF160-HGW RE				
Rated current In (Amp.)		125 150 160		125-160		80-160		125 150 160		125-160		80-160				
Rated ambient temperature (°C)		40		40		40		40		40		40				
Number of poles		2 3 4		2 3 4		3 4		2 3 4		2 3 4		3 4				
Rated insulation voltage Ui (V)		690		690		690		690		690		690				
Rated short-circuit breaking capacities (kA)	IEC60947-2 (Icu/Ics)	AC (50/60Hz)	690V	-	8/8	22/22	22/22	5/3	20/20	20/20	690	690	20/20	20/20		
			525V	-	22/22	22/22	-	35/35	35/35	500V	15/8	30/30	30/30	30/8	50/50	
			440V	25/13	36/36	36/36	50/13	65/65	65/65	415V	30/15	36/36	36/36	50/13	70/70	
			415V	30/15	36/36	36/36	50/13	70/70	70/70	400V	30/15	36/36	36/36	50/13	75/75	
			400V	30/15	36/36	36/36	50/13	75/75	75/75	380V	30/15	36/36	36/36	50/13	75/75	
			380V	30/15	36/36	36/36	50/13	75/75	75/75	230V	50/25	85/85	85/85	100/25	100/100	
			230V	50/25	85/85	85/85	100/25	100/100	100/100	DC	250V	15/8 *1	-	-	-	-
			250V	15/8 *1	-	-	40/20 *1	-	-	300V	-	-	20/20 *2	-	-	-
300V	-	20/20 *2	-	-	40/40 *2	-	-	-	-	-	-	-				
Suitability for isolation		●		●		●		●		●		●				
Utilization category		A		A		A		A		A		A				
Reverse connection (terminals unmarked)		●		●		●		●		●		●				
Rated impulse withstand voltage Uimp (kV)		6		8		8		6		8		8				
Pollution degree		2		3		3		2		3		3				
Number of operating cycles		without current		12,000		40,000		40,000		12,000		40,000				
		with current		4,000		20,000		20,000		4,000		20,000				
Overall dimensions (mm)		440V-In/2		4,000		30,000		30,000		4,000		30,000				
		440V-In		4,000		20,000		20,000		4,000		20,000				
		690V-In/2		1,000		1,000		1,000		1,000		1,000				
		690V-In		1,000		1,000		1,000		1,000		1,000		1,000		
		a		105 140		105 140		105 140		105 140		105 140		105 140		
		b		165		165		165		165		165		165		
Mass of front-face type (kg)		c		68		86		68		86		86				
		ca		92		110		92		110		110				
		1.3 1.5 1.9		2.0 2.6		2.0 2.6		1.3 1.5 1.9		2.0 2.6		2.0 2.6				
Installation and connections		Fixed		Screw terminal		●		●		●		●				
		Front		Solderless (box) terminal (SL)		●		●		●		●				
		Rear		Busbar terminal		-		-		-		-				
		Plug-in		Rear (B)		●		●		●		●				
		Rear (PM)		-		-		-		-		-				
		Rear/front IP20 (PM-IP)		-		-		-		-		-				
Cassette-type accessories (option)		IEC 35mm rail		Mounting hook (option)		-		-		-		-				
		Adapter (option)		-		-		-		-		-				
Accessorie's connection (option)		Alarm switch (AL)		●		●		●		●		●				
		Auxiliary switch (AX)		●		●		●		●		●				
		Shunt trip (SHT)		●		●		●		●		●				
		Undervoltage trip (UVT)		Non-Synchronous Closing (UVT-N)		-		-		-		-				
Built-in accessories (option)		Synchronous Closing (UVT-S)		-		-		-		-		-				
		with Lead-wire terminal block (SLT)		-		-		-		-		-				
		with Internal terminal type (INT)		-		-		-		-		-				
External accessories (option)		with Flying leads		-		-		-		-		-				
		Pre-alarm (contact output) *3 (PAL)		-		-		-		-		-				
		Overcurrent trip alarm *3 (OAL)		-		-		-		-		-				
Marine approval		Cylinder key lock Available soon		-		-		-		-		-				
		Enclosure		Dustproof (S)		●		●		●		●				
		Waterproof (I)		-		-		-		-		-				
		Waterproof (W)		●		●		●		●		●				
		Electrical operation device (MD)		●		●		●		●		●				
		Mechanical interlock (MI)		●		●		●		●		●				
		Handle lock device		Handle lock (HL)		●		●		●		●				
		Lock cover (HL-S)		●		●		●		●		●				
		Lock cover (LC)		●		●		●		●		●				
		External operating handle		Door mounting (V)		●		●		●		●				
Terminal cover		Mounted on breaker (S)		●		●		●		●		●				
		Insulating barrier		Between phase (BA-F)		●		●		●		●				
		To ground (BA-G)		-		-		-		-		-				
		Large (TC-L)		●		●		●		●		●				
		Small (TC-S)		●		●		●		●		●				
		Transparent (TTC)		●		●		●		●		●				
Automatic tripping device		for rear connection (BTC)		●		●		●		●		●				
		for plug-in (PTC)		●		●		●		●		●				
		L/R		-		-		-		-		-				
		G/L		-		-		-		-		-				
Trip button		BV		-		-		-		-		-				
		DNV		-		-		-		-		-				
		ABS		-		-		-		-		-				
		Thermal-magnetic		Thermal-magnetic		Electronic		Thermal-magnetic		Thermal-magnetic		Electronic				

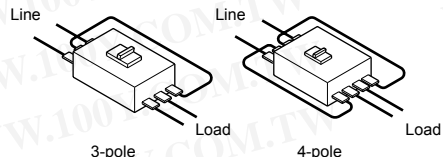

Notes *1: Use two poles in the case of three-pole or four-pole products. In addition, wiring as shown to the right allows the three poles to be used for up to 400V DC and the four poles to be used for up to 500V DC.
 *2: Use two poles in the case of three-pole or four-pole products. In addition, wiring as shown to the right allows the three poles to be used for up to 500V DC and the four poles to be used for up to 600V DC.
 *3: Both PAL and OAL is not available. Only one specified.



Detailed Specifications

12485

Molded-Case Circuit Breakers

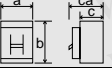
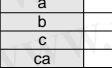
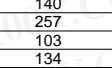





Series		C series		S series			H series	
Frame Size		400		400			400	
Photo								
Type name		NF400-CP		NF400-SP			NF400-SEP	
Rated current In (Amp.)		250 300 350 400		250 300 350 400			200~400 adjustable	
Rated ambient temperature (°C)		40		40			40	
Number of poles		2 3		2 3 4			3 4	
Rated insulation voltage Ui (V)		600		690			690	
Rated short-circuit breaking capacities (kA)	IEC60947-2 (Icu/Ics)	AC (50/60Hz)	690V	10/10(5/5) *1			10/10(5/5) *1	
			500V	30/30(25/25) *1			50/50	
			440V	42/42(36/36) *1			65/65	
			415V	45/45(36/36) *1			70/70	
			400V	45/45(36/36) *1			70/70	
			380V	50/50(42/42) *1			70/70	
			230V	85/85(65/65) *1			100/100	
		DC	20/10 *4	40/40 *4			-	
Suitability for isolation \rightarrow *		●		●			●	
Utilization category		A		A			B	
Rated short-time withstand current Icw (kA)		-		-			5	
Reverse connection (terminals unmarked)		●		●			●	
Rated impulse withstand voltage Uimp (kV)		8		8			8	
Pollution degree		3		3			3	
Overall dimensions (mm)								
		a		140			140 185	
		b		257			257	
		c		103			103	
		ca		134			155	
Mass of front-face type (kg)		4.7 5.5		4.9 5.7 7.5			6 7.8	
Installation and connections	Fixed	Front	Screw terminal	-			-	
			Solderless (box) terminal (SL)	●			●	
	Rear	Busbar terminal	Busbar terminal	●			●	
			Busbar terminal (B)	●			●	
Plug-in	Rear	PM (PM)	●			●		
		PM-IP (PM-IP)	-			-		
Cassette-type accessories (option)	Rear/front	IP20	-			-		
		Alarm switch (AL)	●			●		
		Auxiliary switch (AX)	●			●		
		Shunt trip (SHT)	●			●		
		Undervoltage trip (UVT)	●			●		
Accessories' connection (option)	with	Lead-wire terminal block (SLT)	●			●		
		Internal terminal type (INT)	-			-		
		Flying leads	-			-		
Built-in accessories (option)	Pre-alarm (contact output) *3	PAL	-			● *2		
		Overcurrent trip alarm *3 (OAL)	-			● *2		
		Trip indicator (TI)	-			-		
External accessories (option)	Enclosure	Dustproof	(S)	-			-	
			(I)	●			-	
			Waterproof (W)	●			-	
	Electrical operation device	Motor-operated type	(MD)	●			●	
			Spring-charge type (MDS)	●			●	
	Mechanical interlock	Handle lock device	(MI)	●			●	
			Handle lock (HL)	●			●	
	Lock cover	Handle lock	(HL-S)	-			-	
			(LC)	-			-	
	External operating handle	Door mounting	(V)	●			●	
			(S)	●			●	
			(R)	●			●	
	Insulating barrier	Mounted on breaker	(F)	●			●	
			Between phase (BA-F)	●			●	
			To ground (BA-G)	●			●	
Terminal cover	Large	(TC-L)	●			-		
		Small (TC-S)	-			-		
		Transparent (TTC)	●			●		
		for rear connection (BTC)	●			●		
Marine approval	for plug-in	(PTC)	●			-		
		L/R	●			-		
		G/L	●			-		
		BV	●			-		
Automatic tripping device	Trip button	DNV	-			-		
		ABS	●			-		
		Thermal-magnetic	Thermal-magnetic			Electronic		
		Equipped		Equipped			Equipped	

Notes *1: In case of solderless terminal, interrupting capacity reduces: (/).
 *2: Solid state relay output is option. Please specify if other output is necessary. (Standard type is thus SLT equipped.)
 *3: Both PAL and OAL is not available. Only one specified.
 *4: Specify if for DC use.

Detailed Specifications

12485

Molded-Case Circuit Breakers

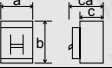
Series		C series	S series		H series		U series		
Frame Size		800	800		800		800		
Photo									
Type name		NF800-CEP	NF800-SDP	NF800-SEP	NF800-HEP	NF800-REP	NF800-UEP		
Rated current In (Amp.)		400~800 adjustable	(700) 800	400~800 adjustable	400~800 adjustable	400~800 adjustable	400~800 adjustable		
Rated ambient temperature (°C)		40	40	40	40	40	40		
Number of poles		3	2	3 4	3 4	3	3 4		
Rated insulation voltage Ui (V)		600	—	690	690	690	690		
Rated short-circuit breaking capacities (kA)	IEC60947-2 (Icu/Ics)	AC (50/60Hz)	690V	—	10/10	15/15	20/15	35/35	
			500V	18/9	—	30/30	50/50	70/35	170/170
			440V	36/18	—	42/42	65/65	125/63	200/200
			415V	36/18	—	45/45	70/70	125/63	200/200
			400V	36/18	—	45/45	70/70	125/63	200/200
			380V	40/20	—	50/50	70/70	125/63	200/200
			230V	50/25	—	85/85	100/100	150/75	200/200
			250V	—	40/40 *4	—	—	—	—
Suitability for isolation \rightarrow *		●	●	●	●	●	●		
Utilization category		B	A	B	B	B	B		
Rated short-time withstand current low (kA)		9.6	—	9.6	9.6	9.6	9.6		
Reverse connection (terminals unmarked)		●	●	●	●	●	●		
Rated impulse withstand voltage Uimp (kV)		8	8	8	8	8	8		
Pollution degree		3	3	3	3	3	3		
Overall dimensions (mm)			a: 210, b: 275, c: 103, ca: 155	a: 210, b: 275, c: 103, ca: 155	a: 210, b: 275, c: 103, ca: 155	a: 210, b: 275, c: 103, ca: 155	a: 210, b: 322, c: 200, ca: 252		
Mass of front-face type (kg)		10.9	9	10.9 14.2	10.9 14.2	10.9	27.6 33.7		
Installation and connections	Fixed	Front	Screw terminal	—	—	—	—		
		Rear	Solderless (box) terminal (SL)	●	●	●	●		
	Plug-in	Front	Busbar terminal	●	●	●	●		
		Rear	(B)	●	●	●	●		
Cassette-type accessories (option) *5	Alarm switch	(AL)	●	●	●	●			
	Auxiliary switch	(AX)	●	●	●	●			
Accessories' connection (option)	with Lead-wire terminal block	(SLT)	●	●	●	●			
	with Internal terminal type	(INT)	—	—	—	—			
Built-in accessories (option)	Pre-alarm (contact output) *3	(PAL)	● *2	—	● *2	● *2			
	Overcurrent trip alarm *3	(OAL)	—	—	—	—			
External accessories (option)	Enclosure	Dustproof	(S)	—	—	—	—		
		Waterproof	(I)	●	●	●	●		
		Motor-operated type	(MD)	●	●	●	●		
	Electrical operation device	Spring-charge type	(MDS)	●	●	●	●		
		Mechanical interlock	(MI)	●	●	●	●		
	Handle lock device	Handle lock	(HL)	●	●	●	●		
		Lock cover	(HL-S)	●	●	●	●		
	External operating handle	Lock cover	(LC)	—	—	—	—		
		Door mounting	(V)	●	●	●	●		
		Mounted on breaker	(S)	●	●	●	●		
		Insulating barrier	(R)	●	●	●	●		
		Terminal cover	(F)	●	●	●	●		
	Terminal cover	Between phase	(BA-F)	●	●	●	●		
		To ground	(BA-G)	●	●	●	●		
		Large	(TC-L)	●	●	●	●		
Small		(TC-S)	●	●	●	●			
Marine approval	Transparent	(TTC)	●	●	●	●			
	for rear connection	(BTC)	●	●	●	●			
	for plug-in	(PTC)	—	—	—	—			
Automatic tripping device	L/R	(L/R)	●	—	●	—			
	G/L	(G/L)	●	—	●	—			
	BV	(BV)	●	—	●	—			
	DNV	(DNV)	●	—	●	—			
Trip button	ABS	(ABS)	●	—	●	—			
	Electronic	(E)	—	—	—	—			
Trip button	Thermal-magnetic	(TM)	—	—	—	—			
	Equipped	(EQ)	—	—	—	—			

Notes *1: In case of solderless terminal, interrupting capacity reduces: (/).
 *2: Solid state relay output is option . Please specify if other output is necessary. (Standard type is thus SLT equipped.)
 *3: Both PAL and OAL is not available. Only one specified.
 *4: Specify if for DC use.
 *5: Cassette-type accessories are not suitable for NF1000-SS, NF1000-SSD, NF1250-SS, NF1250-SSD, NF1250-UR, NF1600-SS, and NF1600-SSD.

Characteristics and Dimensions

12485

Molded-Case Circuit Breakers and Motor Breakers

NF30-CS
MB30-CS



Type NF30-CS

Series		C series		
Frame size		30		
Type name		NF30-CS	MB30-CS	
Rated current In (A) at ambient temperature 30°C		3, 5, 10, 15, 20, 30	(2), (3.2), 4, (5), 6.3, (8), 10, 16, 25, 32	
Number of poles		2	3	
Rated insulation voltage Ui (V)		AC 500		
Rated breaking capacity (kA)	IEC60947-2 (Icu/Ics)	AC	690V	—
			500V	—
		DC	415V	1.5/1.5
			380V	1.5/1.5
			240V	2.5/2
Suitability for isolation		—		
Utilization category		A		
Reverse connection		—		
Rated impulse withstand voltage Uimp (kV)		4		
Pollution degree		2		

Operating Characteristics

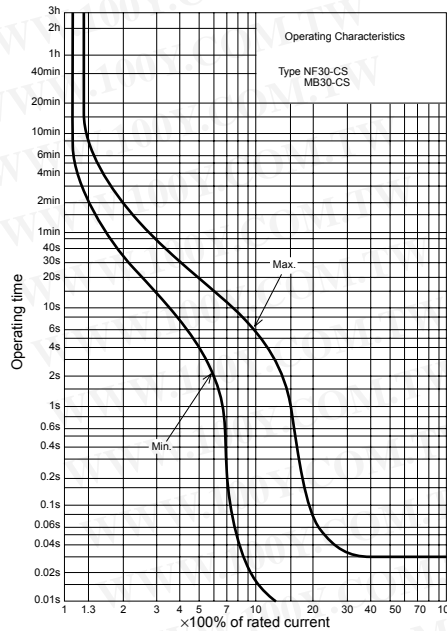

Internal Accessories

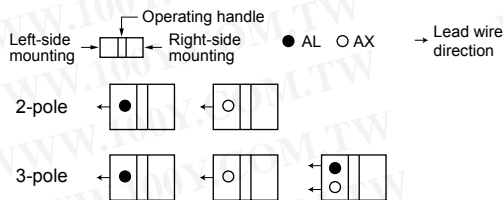

Remark: (1) Standard lead wire is drawn from side. However, lead wire drawn by load can be produced upon request.
(2) refer to page I 0.

Temperature Characteristics

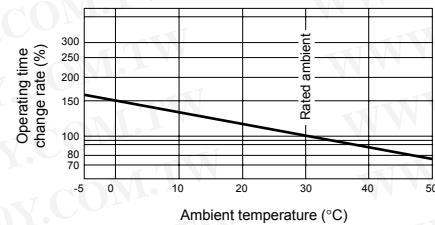

External Accessories

Accessories		Type name	Reference page
Terminal cover	Small	(TC-S) TCS-03CS (*1)	66
	Large	(TC-L) TCL-03CS (*1)	
	Rear	(BTC) BTC-03CS (*1)	
	Skeleton	(TTC) TTC-03CS (*1)	
Handle lock		(HL) HL-05FH	76
Lock cover		(LC) LC03CS	76
Rail mounting adapters		(DIN) DIN-03CS	76

Note: (*1) The designation depends on the number of poles. Refer to the reference page.

Standard Attached Parts (Front connection)

Mounting screw: M4x0.7x20 2pcs

Small terminal cover 2pcs Only MB30-CS

Front connection

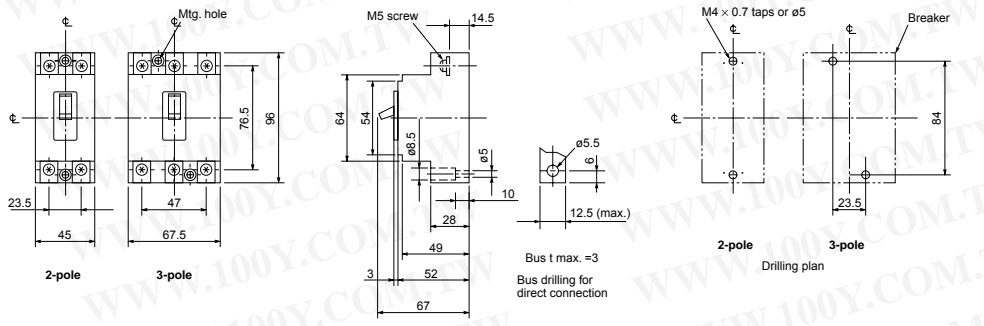

Rear connection

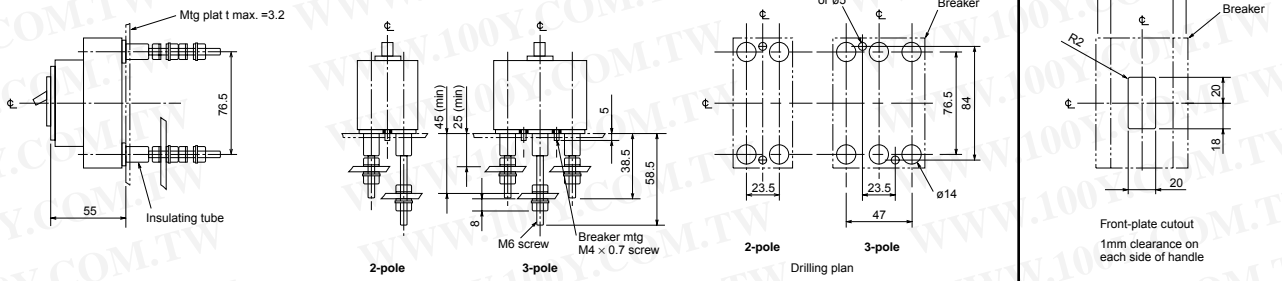

Lead-wire Terminal block (LT)

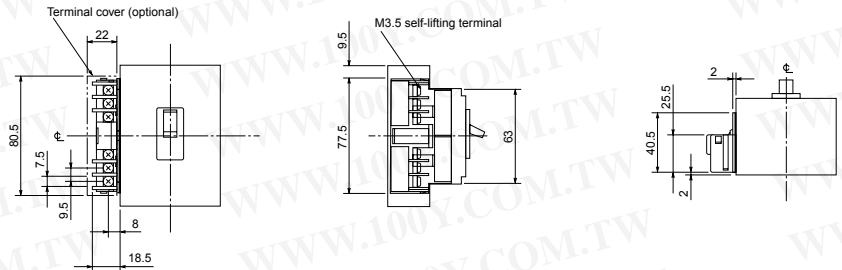

IEC Rail Mounting Adapter

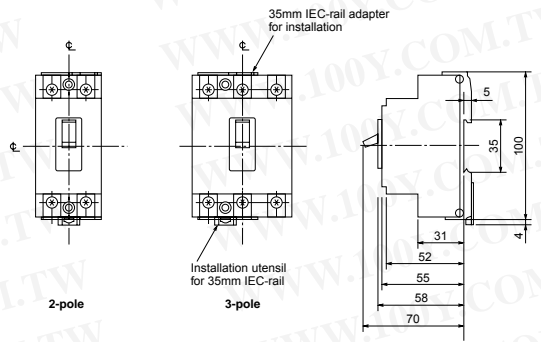

Characteristics and Dimensions

Molded-Case Circuit Breakers and Motor Breakers

NF32-SW **NF63-CW**
NF63-SW **NF63-HW**
MB30-SW **MB50-CW**
MB50-SW



Type NF32-SW

Type name	NF32-SW	NF63-CW	NF63-SW	NF63-HW	MB30-SW	MB50-CW	MB50-SW		
Rated current I _n (Amp.)	3 4 6 10 16 20 25 32	3 4 6 10 16 20 25 32 40 50 63	3 4 6 10 16 20 25 32 40 50 63	10 16 20 25 32 40 50 63	0.8 1.2 1.4 2 2.5 4 5 7.1 8 10 12 16 25	8 10 12 16 25 32 40 45	0.8 1.2 1.4 2 2.5 4 5 7.1		
Number of poles	2 ^{*1} 3	2 ^{*1} 3	2 ^{*1} 3 4	2 ^{*1} 3 4	3	3	3		
Rated insulation voltage U _i (V)	600	600	600	690	500	500	500		
Rated short-circuit breaking capacity (kA)	IEC60947-2 (Icu/Ics)	AC (50/60Hz)	690V	—	—	—	2.5/1	—	—
			500V	2.5/1	2.5/1	7.5/4	7.5/4	—	—
			440V	2.5/1	2.5/1	7.5/4	10/5	2.5/1	2.5/1
			400V	5/2	5/2	7.5/4	10/5	5/2	5/2
			230V	7.5/4	7.5/4	15/8	25/13	7.5/4	7.5/4
DC	250V	2.5/1	—	2.5/1	—	7.5/4	—		
Suitability for isolation	●	●	●	●	●	●	●		
Utilization category	A	A	A	A	A	A	A		
Reverse connection (terminals unmarked)	●	●	●	●	●	●	●		
Rated impulse withstand voltage U _{imp} (kV)	6	6	6	6	6	6	6		
Pollution degree	2	2	2	2	2	2	2		

*1: Types of DC specifications can be produced upon request.

Operating Characteristics

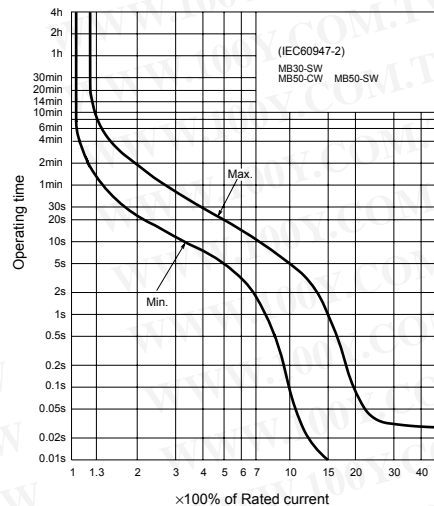
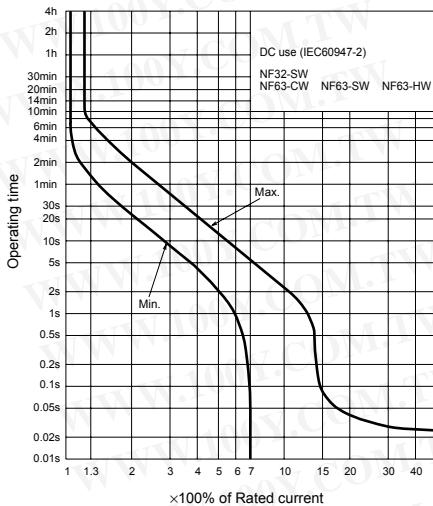
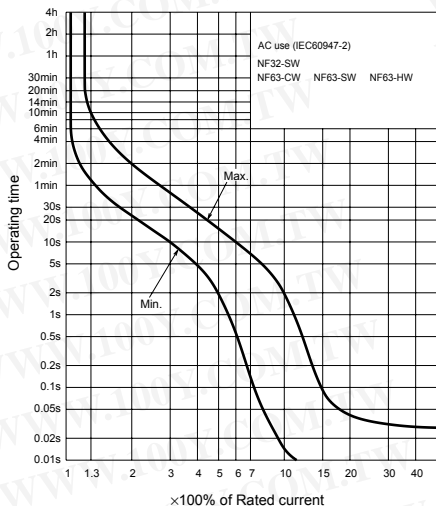

Internal Accessories

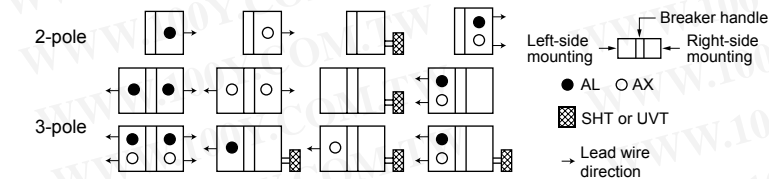

Remark: (1) refer to page 10.

Temperature Characteristics

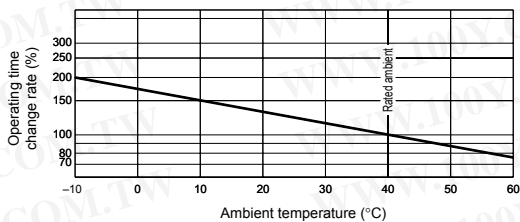

External Accessories

Accessories	Type name	Reference page	Accessories	Type name	Reference page
Operating handle	F F05SW (*1)	11	Mechanical interlock	MI MI-05SW3 (*1)	75
	S S05SW	13		Terminal cover	Small TC-S TCS-05SW3W (*1)
	V V05SWF	10	Large TC-L TCL-05SW3W (*1)		
	R —	—	Skeleton TTC TTC-05SW3 (*1)		
Handle lock device	LC LC-05SW	76	Rear BTC BTC-05SW3W (*1)	Plug-in PTC PTC-05SW3W (*1)	76
	(*2) HLF-05SW				
	HL HLN-05SW				
	HL-S HLS-05SW (*1)				
IEC 35mm rail mounting adapters (option)			DIN-05SW	76	

Notes: (*1) The designation depends on the number of poles. Refer to the reference page.
 (*2) HLF types are used for OFF-lock, and HLN types for ON-lock.

Standard Attached Parts (Front connection)

Mounting screw: M4×0.7×55
 (2 and 3P: 2pcs, 4P: 4pcs)
 (Note)
 Insulation barrier: (2P: 1pc, 3P: 2pcs, 4P: 3pcs)

Note: These are supplied with NF63-SW, NF63-HW, and MB50-SW models.

Front connection

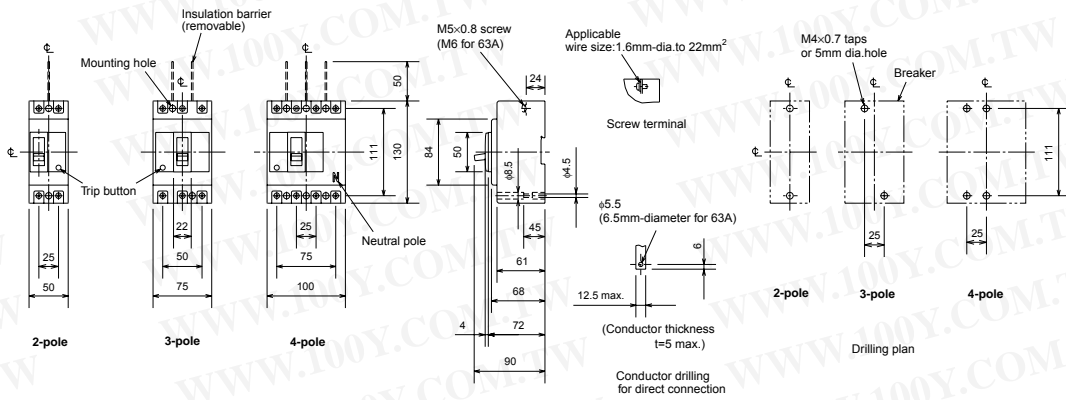

Rear connection

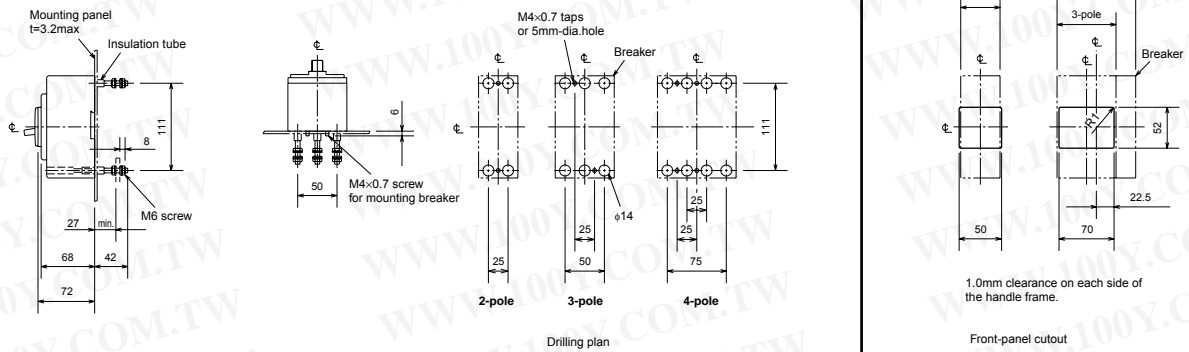

Plug-in

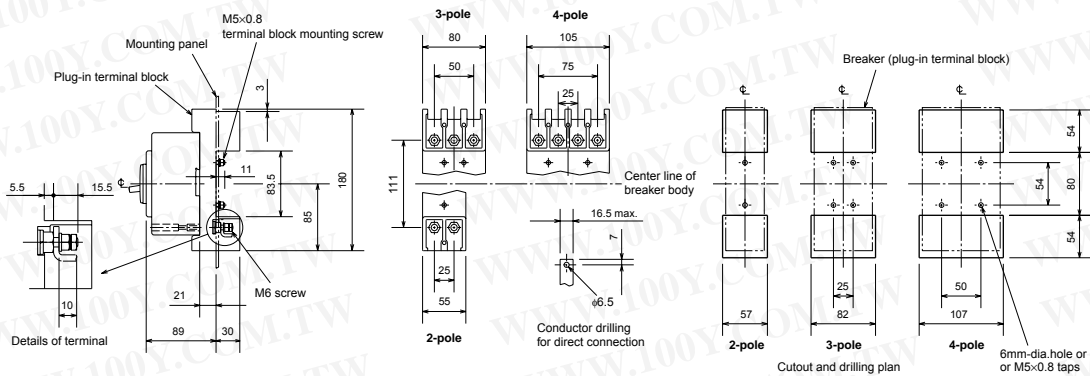

Characteristics and Dimensions

Molded-Case Circuit Breakers and Motor Breakers

NF125-CW NF125-SW
 NF125-HW MB100-SW



Type NF125-CW

Type name		NF125-CW		NF125-SW		NF125-HW		MB100-SW			
Rated current In (Amp.)		50 63 80 100 125		16 20 32 40 50 63 80 100 125		16 20 32 40 50 63 80 100		(12.5) (16) (25) 32 (40) 45 63 71 90 100			
Number of poles		2 3		2 3 4		2 3 4		3			
Rated insulation voltage Ui (V)		600		690		690		500			
Rated short-circuit breaking capacity (kA)	IEC60947-2 (Icu/lcs)	AC (50/60Hz)	690V	-		8/4		10/5		-	
			500V	7.5/4		18/9		30/15		-	
			440V	10/5		25/13		50/25		25/13	
			400V	10/5		30/15		50/25		30/15	
		230V	30/15		50/25		100/50		50/25		
		DC *1	250V	7.5/4	-	15/8	-	40/20	-	-	-
400V	-	7.5/4	-	15/8	-	40/20	-	-	-		
500V	-	-	-	15/8	-	40/20	-	-	-		
Suitability for isolation		●		●		●		●			
Utilization category		A		A		A		A			
Reverse connection (terminals unmarked)		●		●		●		●			
Rated impulse withstand voltage Uimp (kV)		8		8		8		8			
Pollution degree		3		3		3		3			

*1: When wired as shown at the bottom of page 13, 3-pole models can be used for up to 400 V DC, and 4-pole models for up to 500 V DC.

Operating Characteristics

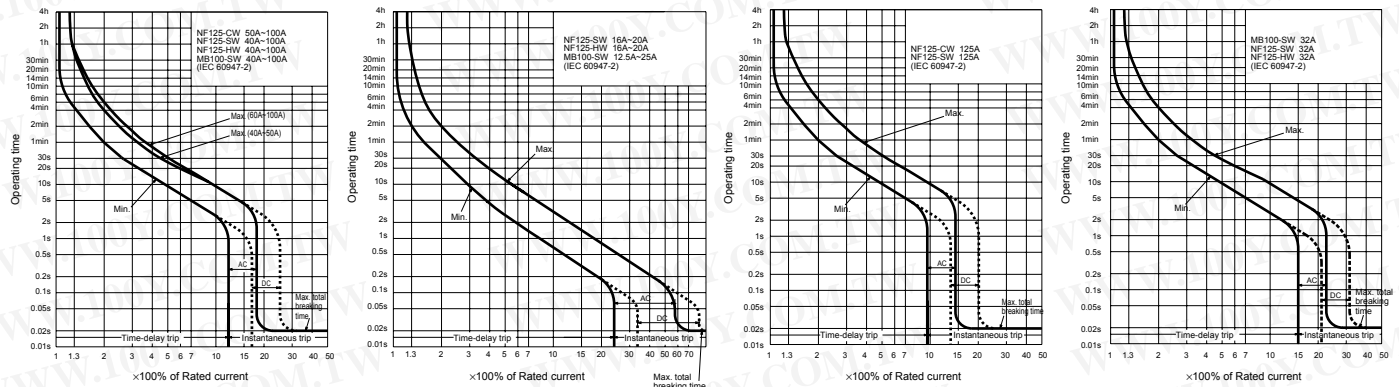

Remark: (1) Only AC characteristics are available for the model MB100-SW.

Internal Accessories

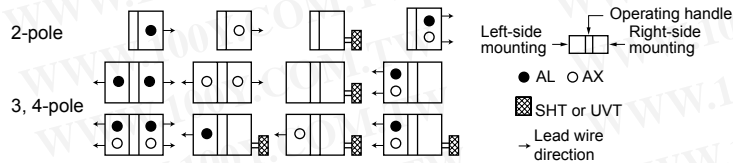

Remark: (1) refer to page 50.

Ambient Compensating Curve

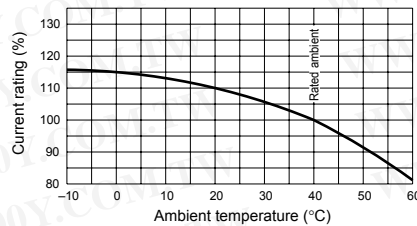

External Accessories

Accessories	Type name	Reference page	Accessories	Type name	Reference page
Operating handle	F F1SW (*1)	61	Mechanical interlock	MI MI-05SW3 (*1)	75
	S S1SW	63		Terminal cover	Small TC-S TCS-1SW3W (*1)
	V V1SW (*2)	60	Large TC-L TCL-1SW3W (*1)		
	R R1SW	64	Skeleton TTC TTC-1SW3 (*1)		
LC LC-1SW	76	Rear BTC BTC-1SW3W (*1)			
(*4) HLF-1SW		Pul-g-in PTC PTC-1SW3W (*1)			
HL HLN-1SW		IEC 35mm rail mounting adapters	DIN-1SW3 (*1)	76	
HL-S HLS-1SW (*1)(*4)		Electrical operation device	MDS-NF1SWE (*3)	67	

Standard Attached Parts (Front connection)

Mounting screw: M4×0.7×55
 (2 and 3P: 2pcs, 4P: 4pcs)
 (Note)
 Insulation barrier: (2P: 1pc, 3P: 2pcs, 4P: 3pcs)

Note: These are supplied with NF125-SW, NF125-HW, and MB100-SW models.

Notes: (*1) The designation depends on the number of poles. Refer to the reference page.
 (*2) Attach the letter "F" to the end of designation for a fixed type.
 (*3) Specify the working voltage. An order should be placed at the same time as an order of circuit breaker main body.
 (*4) HLF and HLS types are used for OFF-lock, and HLN types for ON-lock.

Front connection

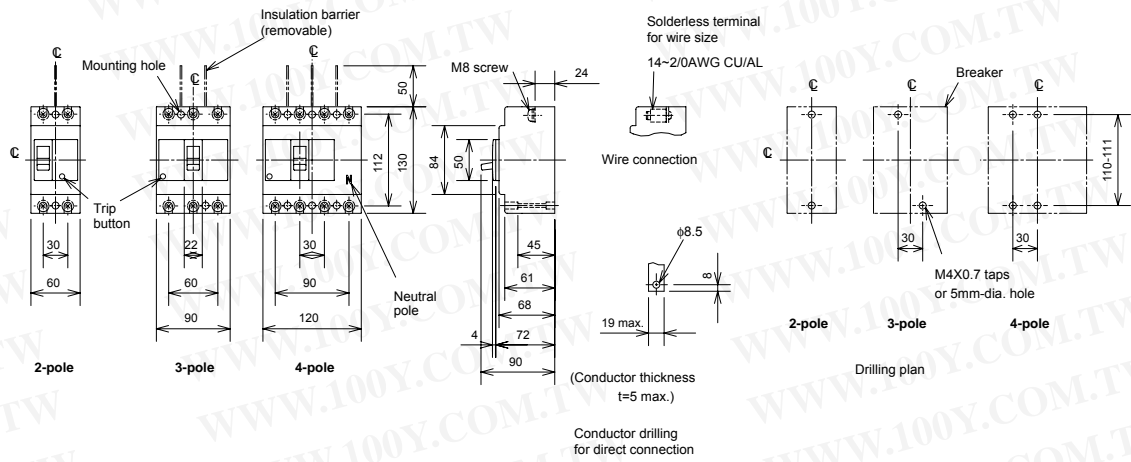

Rear connection

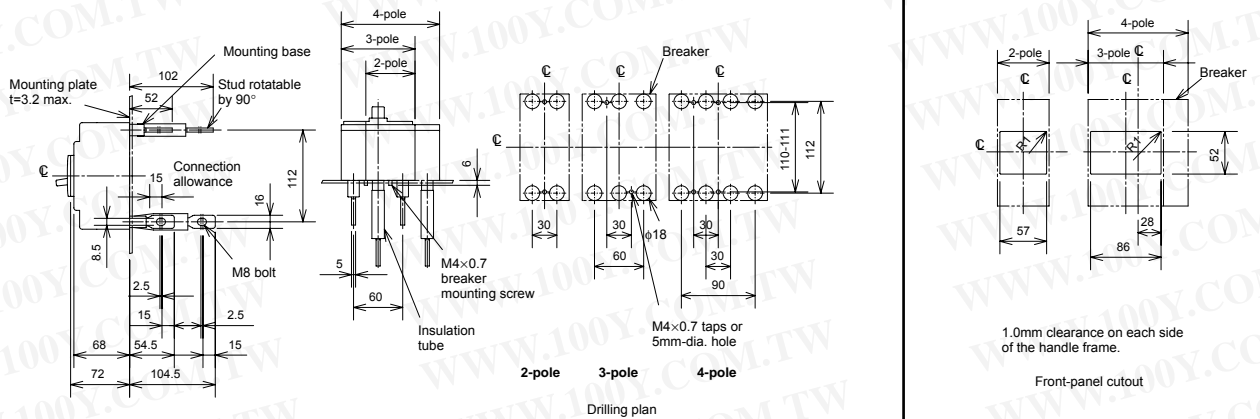

Plug-in

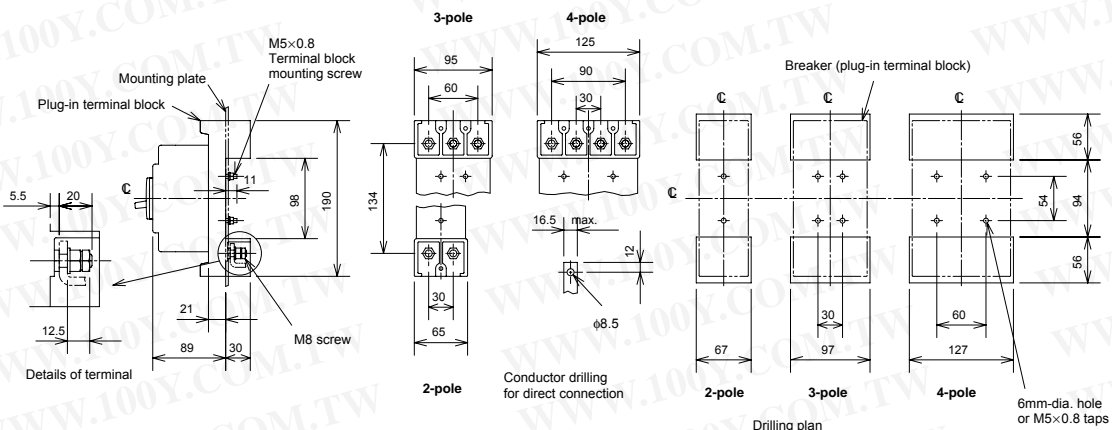

Remark: 2-pole model of NF125-HW are 3-pole model with the central pole removed.

Characteristics and Dimensions

Molded-Case Circuit Breakers and Motor Breakers

NF250-CW **NF250-SW**
NF250-HW **NF160-SW**
NF160-HW **MB225-SW**



Type NF250-CW

Type name		NF160-SW			NF160-HW			NF250-CW			NF250-SW			NF250-HW			MB225-SW				
Rated current In (Amp.)		125	150	160	125	150	160	125	150	175	125	150	175	125	150	175	125	150	175		
Number of poles		2	3	4	2	3	4	2	3		2	3	4	2	3	4	3				
Rated insulation voltage Ui (V)		690			690			600			690			690			500				
Rated short-circuit breaking capacity (kA)	IEC60947-2 (Icu/Ics)	AC (50/60Hz)	690V	-			5/3			-			-			5/3			-		
			500V	15/8	30/8			10/5			15/8			30/8			-				
			440V	25/13	50/13			15/8			25/13			50/13			25/13				
			400V	30/15	50/13			18/9			30/15			50/13			30/15				
			230V	50/25	100/25			35/18			50/25			100/25			50/25				
		DC	250V	15/8	-	40/20	-	10/5	-	15/8	-	40/20	-	-	-	40/20	-	-	-		
400V	-	15/8	-	40/20	-	-	10/5	-	15/8	-	-	40/20	-	-	-	-					
500V	-	15/8	-	40/20	-	-	-	15/8	-	-	40/20	-	-	-	-						
Suitability for isolation		●			●			●			●			●			●				
Utilization category		A			A			A			A			A			A				
Reverse connection (terminals unmarked)		●			●			●			●			●			●				
Rated impulse withstand voltage Uimp (kV)		6			6			6			6			6			6				
Pollution degree		2			2			2			2			2			2				

*1: When wired as shown at the bottom of page 13, 3-pole models can be used for up to 400 V DC, and 4-pole models for up to 500 V DC.

Operating Characteristics

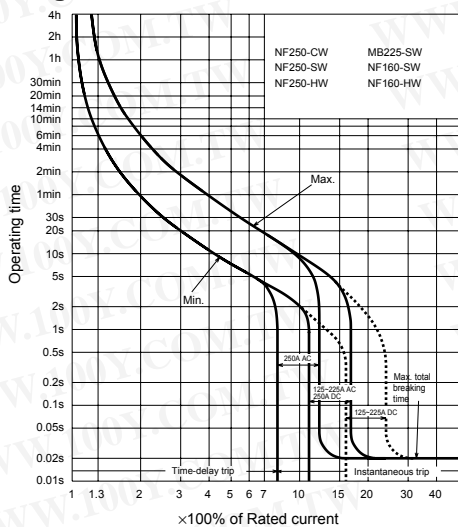

Remark: (1) Only AC characteristics are available for the model MB225-SW.
 (2) refer to page 50.

Ambient Compensating Curve

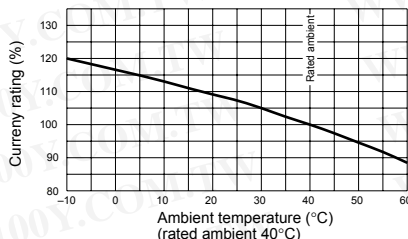

Internal Accessories

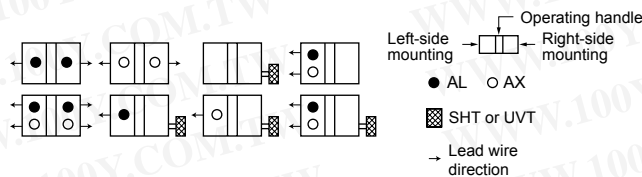

External Accessories

Accessories	Type name	Reference page	Accessories	Type name	Reference page
Operating handle	F F2SW	61	Mechanical interlock	MI MI-05SW3 (*1)	75
	S S2SW	63		Terminal cover	Small TC-S TCS-2SW3W (*1)
	V V2SW (*3)	60	Large TC-L TCL-2SW3W (*1)		
	R R2SW	64	Skeleton TTC TTC-2SW3 (*1)		
LC LC-2SW	76	Rear BTC BTC-2SW3W (*1)			
HL HLF-2SW		Plug-in PTC PTC-2SW3W (*1)			
HLN HLN-2SW		Electrical operation device MDS-NF2SWE (*2)	67		
HL-S HLS-2SW					

Notes: (*1) The designation depends on the number of poles. Refer to the reference page.
 (*2) Specify the working voltage. An order of MB225-SW should be placed at the same time as an order of circuit breaker main body.
 (*3) Attach the letter "F" to the end of designation for a fixed type.
 (*4) HLF types are used for OFF-lock, and HLN types for ON-lock.

Standard Attached Parts (Front connection)

Mounting screw: M4×0.7×55
 (2 and 3P: 2pcs, 4P: 4pcs)
 Insulation barrier: (2P: 2pcs, 3P: 4pcs, 4P: 6pcs)

Front connection

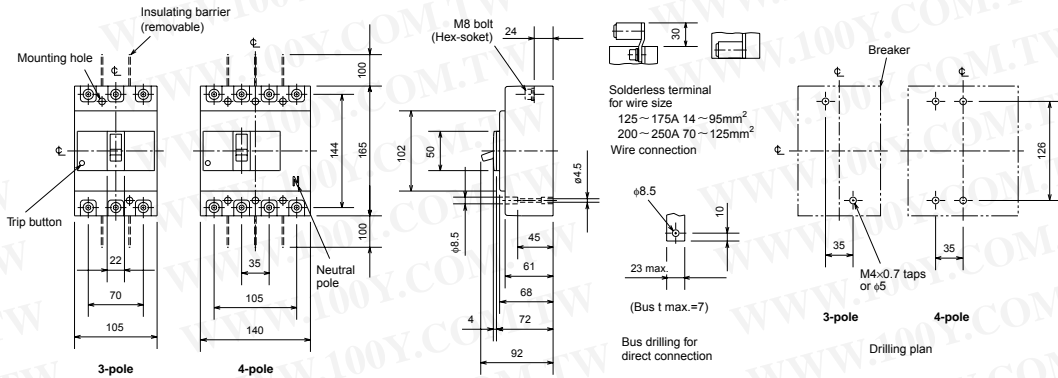

Rear connection

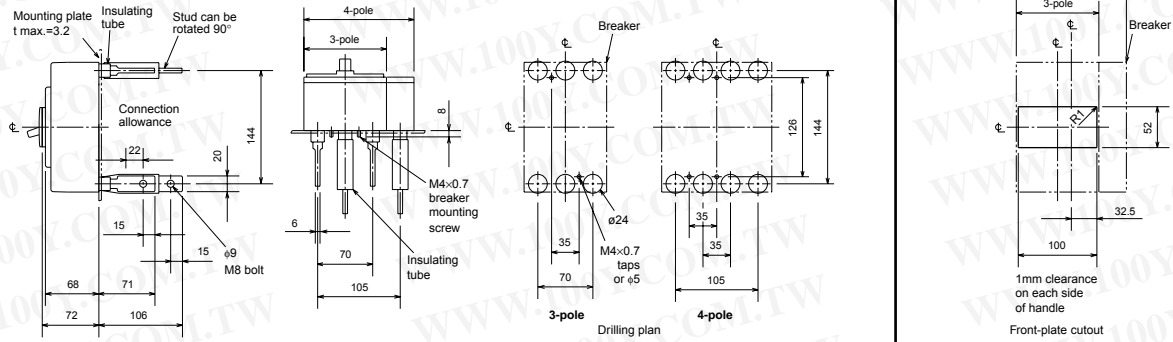

Plug-in

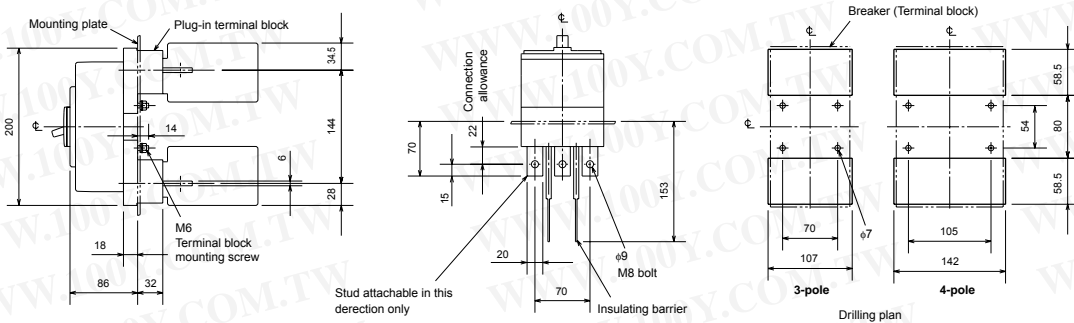

Remarks: 1. 2-pole models are 3-pole models with the central pole removed.
 2. Only 2- and 3-pole models are available for the model of NF250-CW, and only 3-pole models are available for the model of MB225-SW.

Characteristics and Dimensions

Molded-Case Circuit Breakers

NF250-SGW NF250-HGW
NF160-SGW NF160-HGW
NF125-SGW NF125-HGW



Type NF250-SGW

Type name	NF125-SGW RT	NF125-SGW RE	NF125-HGW RT	NF125-HGW RE	NF160-SGW RT	NF160-SGW RE			
Rated current In (Amp.)	16-25, 25-40, 40-63, 63-100, 80-125	16-32, 32-63, 63-100, 75-125	16-25, 25-40, 40-63, 63-100, 80-125	16-32, 32-63, 63-100, 75-125	125-160	80-160			
Number of poles	2 3 4	3 4	2 3 4	3 4	2 3 4	3 4			
Rated insulation voltage Ui (V)	690	690	690	690	690	690			
Rated short-circuit breaking capacity (kA)	IEC 60947-2 (Icu/Ics)	AC (50/60Hz)	690V	8/8	8/8	20/20	20/20	8/8	8/8
			500V	30/30	30/30	50/50	50/50	30/30	30/30
			440V	36/36	36/36	65/65	65/65	36/36	36/36
			400V	36/36	36/36	75/75	75/75	36/36	36/36
			230V	85/85	85/85	100/100	100/100	85/85	85/85
			300V	20/20	—	40/40	—	20/20	—
			500V	—	20/20	—	40/40	—	20/20
600V	—	20/20	—	40/40	—	20/20			
Suitability for isolation	●	●	●	●	●	●			
Utilization category	A	A	A	A	A	A			
Reverse connection (terminals unmarked)	●	●	●	●	●	●			
Rated impulse withstand voltage Uimp (kV)	8	8	8	8	8	8			
Pollution degree	3	3	3	3	3	3			

Type name	NF160-HGW RT	NF160-HGW RE	NF250-SGW RT	NF250-SGW RE	NF250-HGW RT	NF250-HGW RE			
Rated current In (Amp.)	125-160	80-160	125-160, 160-250	125-250	125-160, 160-250	125-250			
Number of poles	2 3 4	3 4	2 3 4	3 4	2 3 4	3 4			
Rated insulation voltage Ui (V)	690	690	690	690	690	690			
Rated short-circuit breaking capacity (kA)	IEC 60947-2 (Icu/Ics)	AC (50/60Hz)	690V	20/20	20/20	8/8	8/8	20/20	20/20
			500V	50/50	50/50	30/30	30/30	50/50	50/50
			440V	65/65	65/65	36/36	36/36	65/65	65/65
			400V	75/75	75/75	36/36	36/36	75/75	75/75
			230V	100/100	100/100	85/85	85/85	100/100	100/100
			300V	40/40	—	20/20	—	40/40	—
			500V	—	40/40	—	20/20	—	40/40
600V	—	40/40	—	20/20	—	40/40			
Suitability for isolation	●	●	●	●	●	●			
Utilization category	A	A	A	A	A	A			
Reverse connection (terminals unmarked)	●	●	●	●	●	●			
Rated impulse withstand voltage Uimp (kV)	8	8	8	8	8	8			
Pollution degree	3	3	3	3	3	3			

*1: Use either 2-pole. When wired as shown at the bottom of page 13, 3-pole models can be used for up to 500 V DC, and 4-pole models for up to 600V DC.

Operating Characteristics

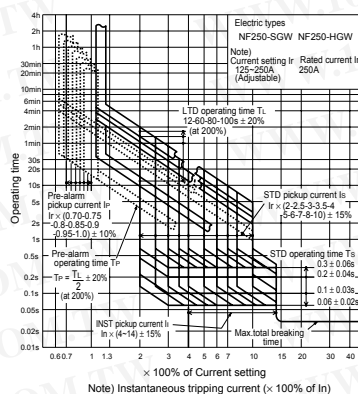
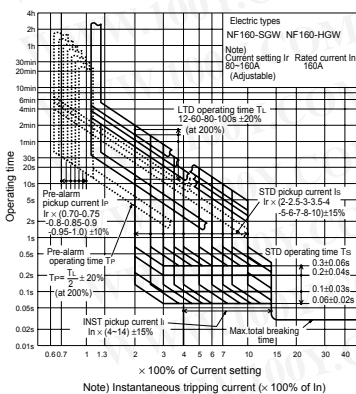
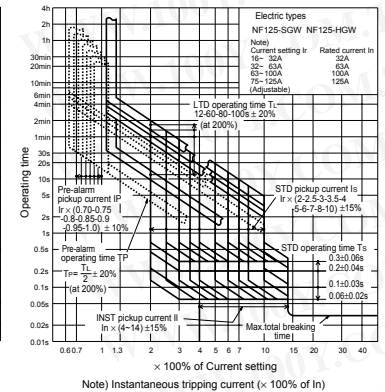
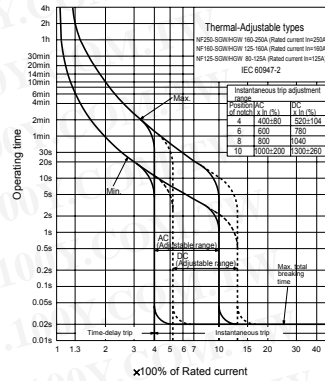
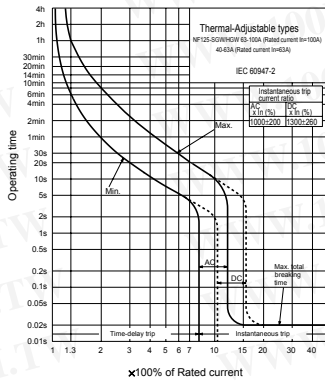
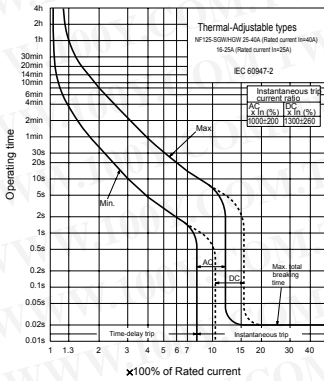

Ambient Compensating Curve

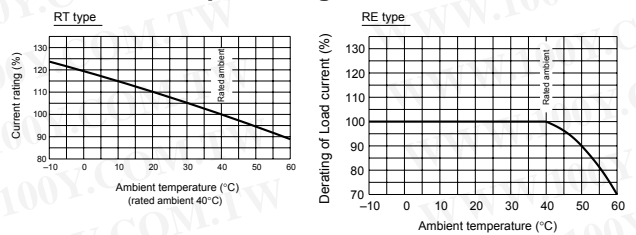

Standard Attached Parts (Front connection)

Mounting screw : M4 × 0.7 × 73 (4pcs)
 Insulation barrier : (2P : 2pcs, 3P : 4pcs, 4P : 6pcs)

Internal Accessories

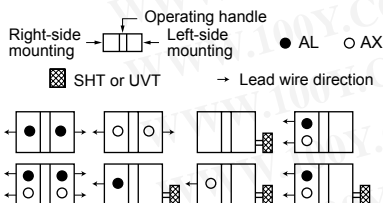

Remark: (1) refer to page 50.

External Accessories

Accessories	Type name	Reference page	Accessories	Type name	Reference page	
Operating handle	F F2GSW	61	Mechanical interlock	MI MI-05SW3 (*1)	75	
	S S2GSW	63		Terminal cover	Small TC-S TCS-2GSW3W (*1)	66
	V V2GSW (*3)	60			Large TC-L TCL-2GSW3W (*1)	
	R R2GSW	64			Skeleton TTC TTC-2GSW3 (*1)	
Handle lock device	LC LC-2GSW	76	Rear BTC BTC-2GSW3W (*1)	Electrical operation device	MDS-NF2GSWE (*4)	
	HL HLF-2GSW		Plug-in PTC PTC-2GSW3W (*1)			
	HL HLN-2GSW					
OFF Lock with 3 Padlock	HLF3-2GSW	76				

Notes:
 (*1) The designation depends on the number of poles. Refer to the reference page.
 (*2) HLF types are used for OFF-lock, and HLN types for ON-lock.
 (*3) Attach the letter "F" to the end of designation for a fixed type.
 (*4) Specify the working voltage.

Front connection

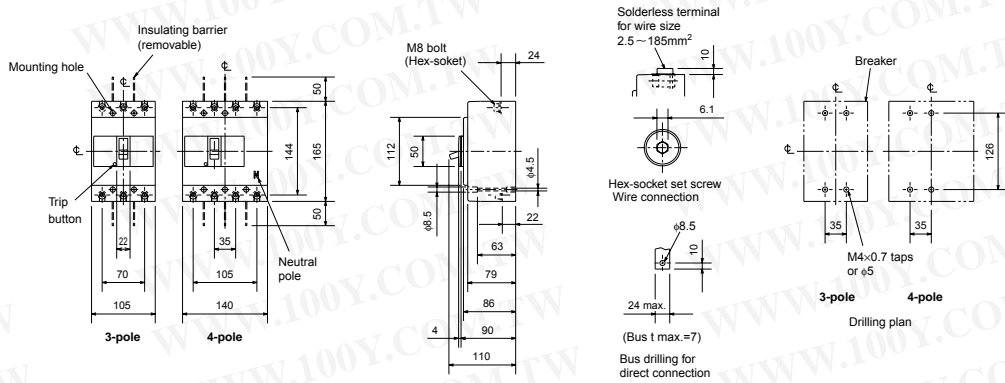

Rear connection

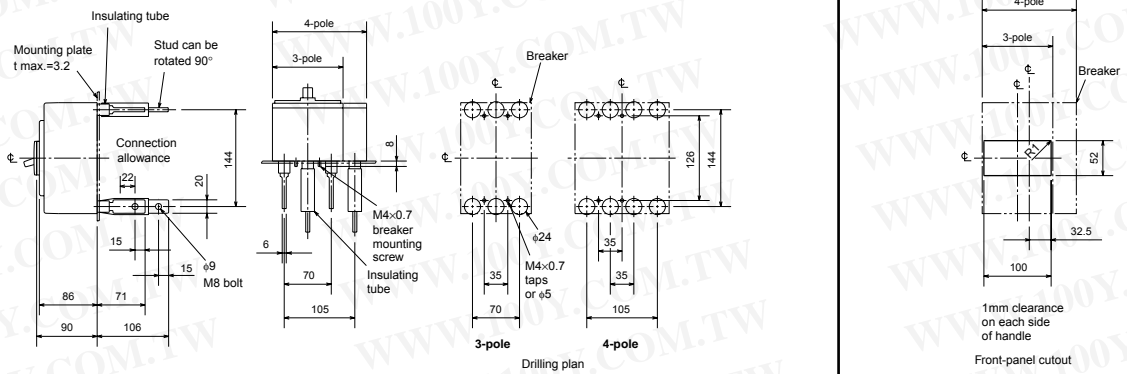

Plug-in

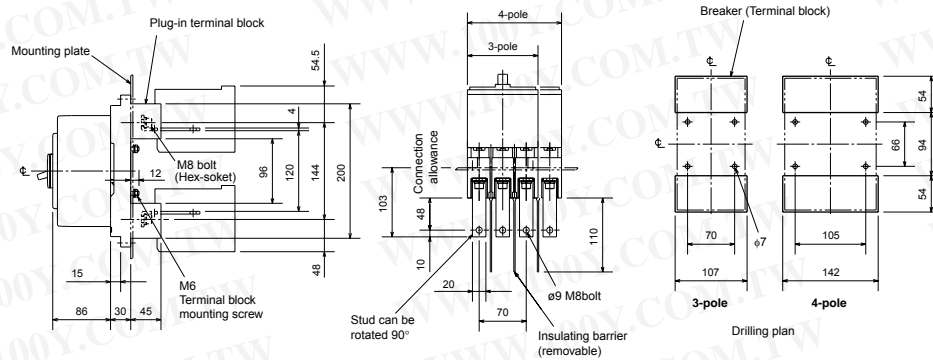

Remark: 2-pole models are 3-pole models with the central pole removed.

Characteristics and Dimensions

12485

Molded-Case Circuit Breakers

NF250-RGW NF250-UGW
NF125-RGW NF125-UGW



Type NF250-UGW

Type name	NF125-RGW RT	NF125-UGW RT	NF250-RGW RT	NF250-UGW RT				
Rated current In (Amp.)	16-25 25-40 40-63 63-100	16-25 25-40 40-63 63-100	125-160 160-225	125-160 160-225				
Number of poles	2 3	2 3 4	2 3	2 3 4				
Rated insulation voltage Ui (V)	690		690					
Rated short-circuit breaking capacity (kA)	IEC60947-2 (Icu/Ics)	AC (50/60Hz)	DC	690V	25/25	30/30	25/25	30/30
				500V	125/125	200/200	125/125	200/200
				440V	125/125	200/200	125/125	200/200
				400V	125/125	200/200	125/125	200/200
				230V	125/125	200/200	125/125	200/200
				300V	-	-	-	-
500V	-	-	-	-				
600V	-	-	-	-				
Suitability for isolation	●		●					
Utilization category	A		A					
Reverse connection (terminals unmarked)	●		●					
Rated impulse withstand voltage Uimp (kV)	8		8					
Pollution degree	3		3					

Operating Characteristics

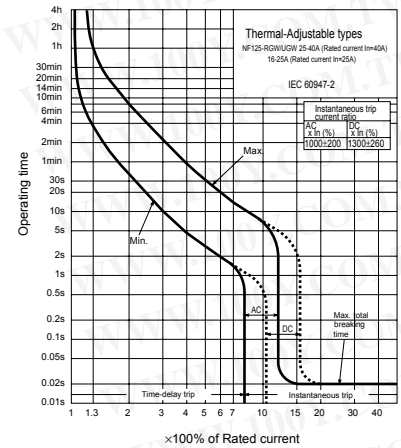
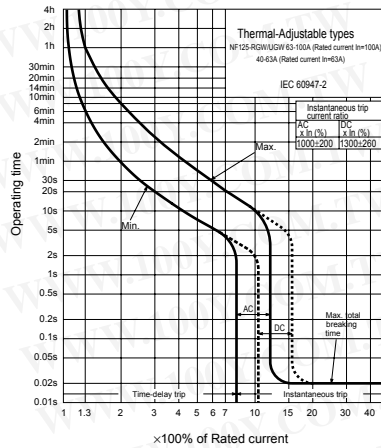
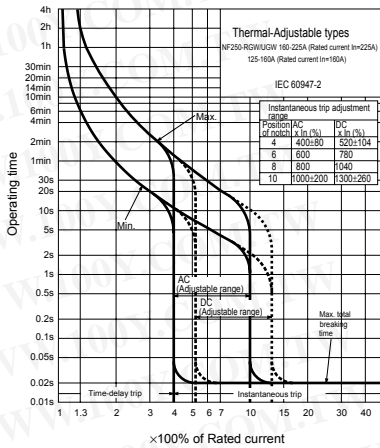

Internal Accessories

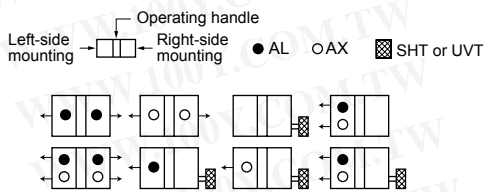

Remark: (1) refer to page 50.

Ambient Compensating Curve

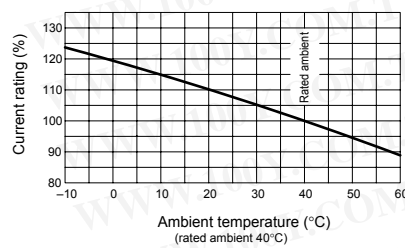

External Accessories

Accessories	Type name	Reference page	Accessories	Type name	Reference page			
Operating handle	F	—	Terminal cover	Small	TC-S	66		
	S	—		Large	TC-L			
	V	V2GUW		60	Skeleton		TTC	TTC-2GSW3 (*1)
	R	R2GUW		64	Rear		BTC	BTC-2GSW3 (*1)
Mechanical interlock	MI	MI-05SW3 (*1)		75	Plug-in		PTC	PTC-2GSW3 (*1)
Electrical operation device	—	—	Handle lock device	LC	LC-2GSW	76		
	—	—		(*2) HLF	HLF-2GSW			
	—	—		HL-S	HLS-2GSW			

Notes: (*1) The designation depends on the number of poles. Refer to the reference page.
 (*2) HLF and HLS types are used for OFF-lock, and HLN types for ON-lock.

Standard Attached Parts (Front connection)

Mounting screw: M4×0.7×73 (4pcs)
 Insulation barrier: (2P : 2pcs, 3P : 4pcs, 4P : 6pcs)

Front connection

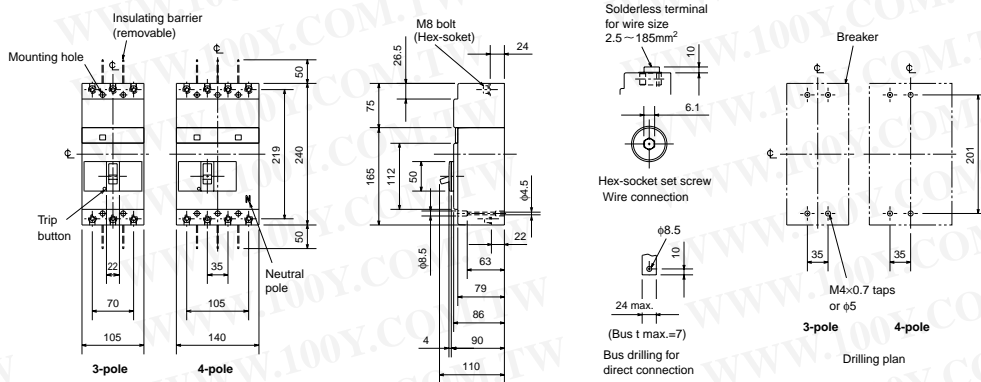

Rear connection

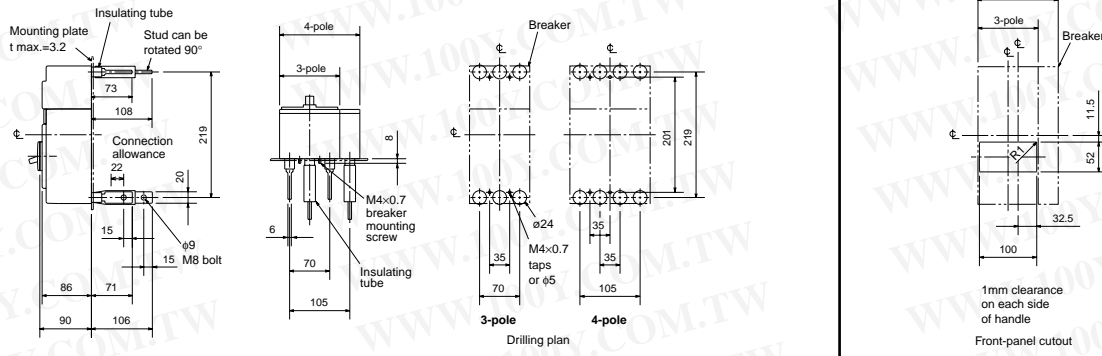

Plug-in

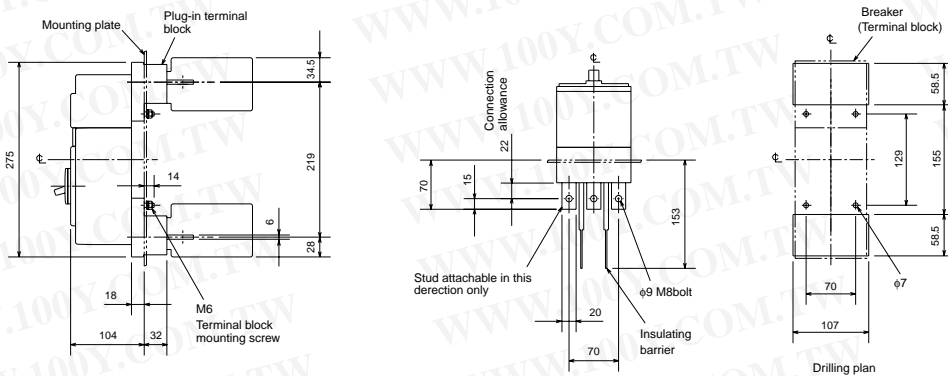

Remark: 2-pole models are 3-pole models with the central pole removed.

Characteristics and Dimensions

12485

Molded-Case Circuit Breakers

NF400-CP
NF400-SP



Type NF400-SP

Type name		NF400-CP		NF400-SP		
Rated current In (Amp.)		250	300	350	400	
Number of poles		2	3	2	3	4
Rated insulation voltage Ui (V)		AC		690		
		DC(*1)		250	-	250
Rated short-circuit breaking capacity (kA)	IEC 60947-2 (Icu/lcs)	AC	690V	-	10/10	
			500V	15/8	30/30	
			440V	25/13	42/42	
		DC	400V	36/18	45/45	
			230V	50/25	85/85	
			250V	20/10	-	40/40

Note: (*1)Types of DC specifications can be produced upon request.

Operating Characteristics

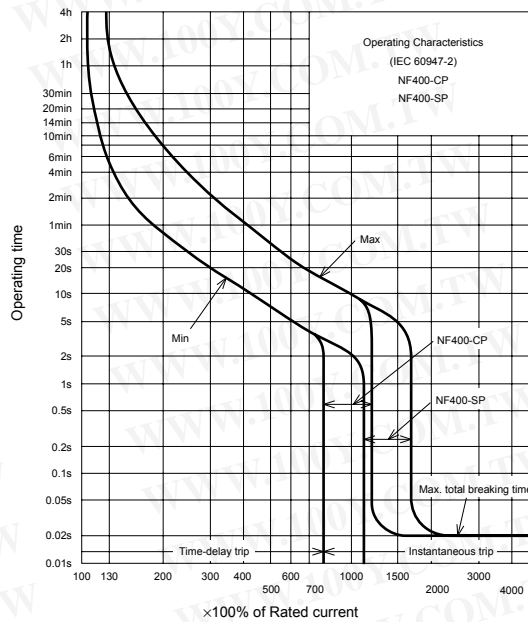

Internal Accessories

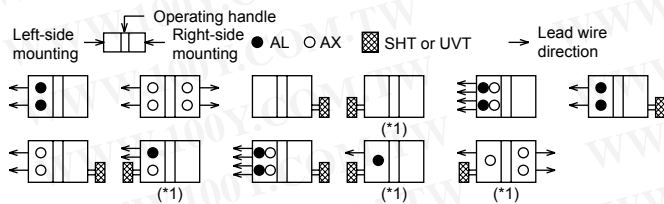

Note: (*1) Right-side mounting is standard of SHT and UVT. Specify separately for left-side mounting.
Remark: (1) refer to page 51.

Ambient Compensating Curve

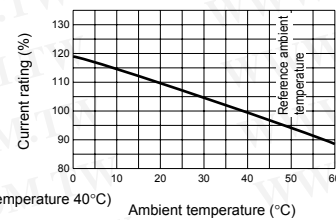

External Accessories

(An order for ☆ should be placed at the same time as an order of circuit breaker main body.)

Accessories	Type name	Reference page	Accessories	Type name	Reference page	
Operating handle	F	F4SPW	61	Large (TC-L)	TCL-4SP3W (*1)	66
	S	S4CP, S4SP	63	Skeleton (TTC)	TTC-4SP3 (*1)	
	V	V4SPWF, V4SPW	60	Rear (BTC)	BTC-4SP3W (*1)	
Mechanical interlock (MI)	MI-4SP3 (*1)	75	Handle lock device	HL	HL-4CP, HL-4SP	76
Auxiliary handle (HT)	HT	HT-4CP, HT4SP	76	HL-S	HLS-4SP	67
				Electrical operation device	☆	

Note: (*1) The designation depends on the number of poles. Refer to the reference page.

Standard Attached Parts

Front connection	Mounting screw: M6 × 60 (4pcs) Insulating barrier: (2P: 2pcs, 3P: 4pcs, 4P: 6pcs)
Rear connection	Mounting screw: M6 × 72 (4pcs)

Front connection

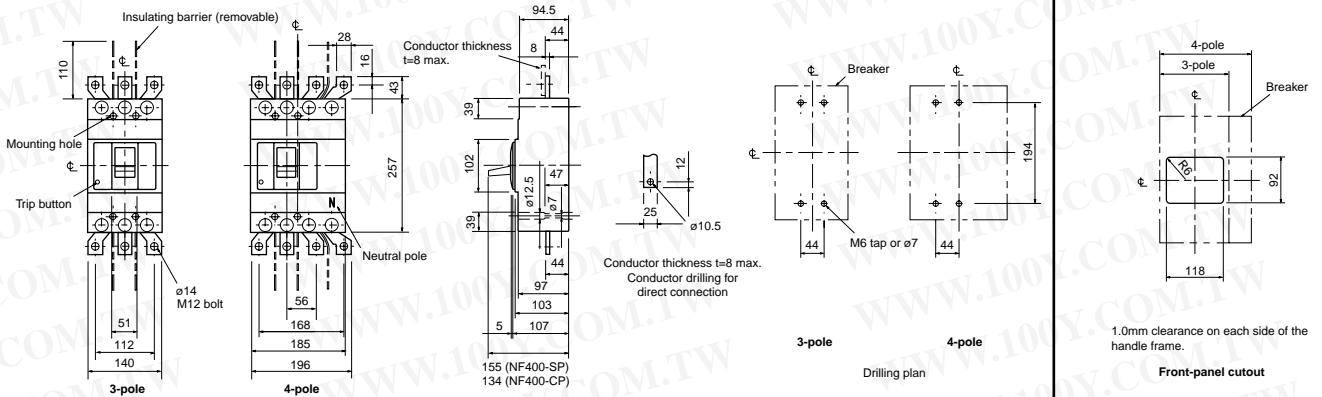

Rear connection

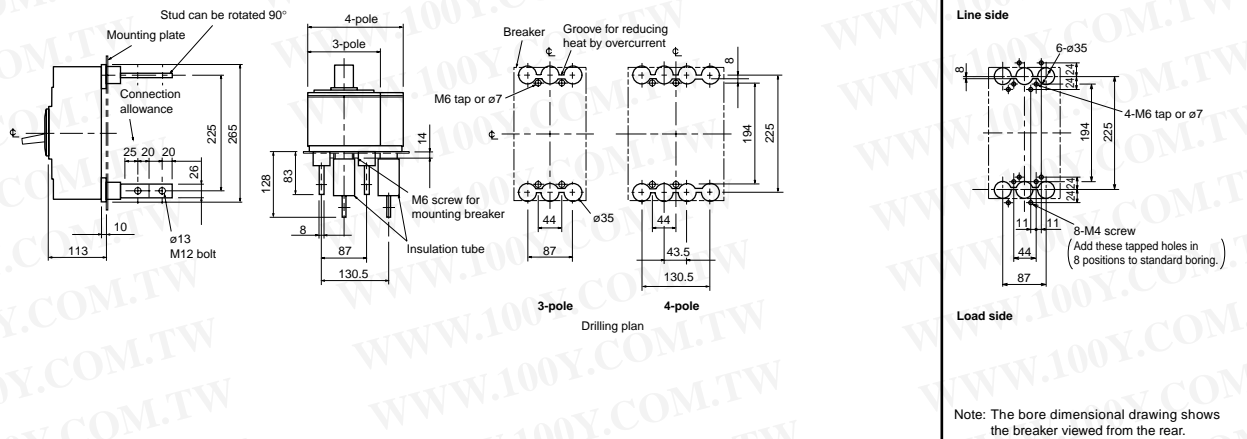

Plug-in

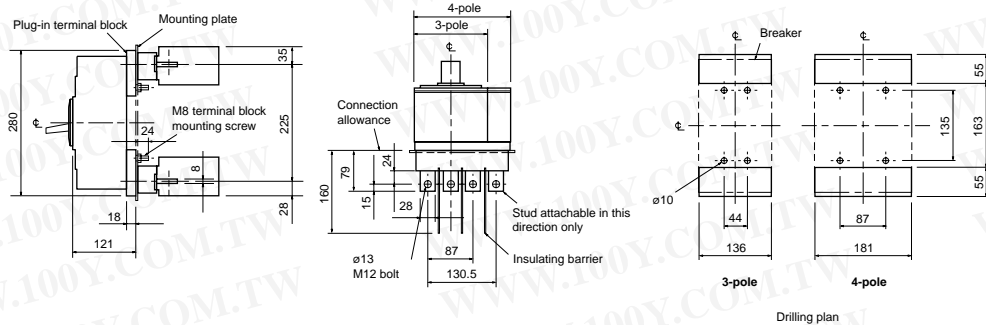

Remark: (1) 2-pole models are 3-pole models with the central pole removed.

Characteristics and Dimensions

12485

Molded-Case Circuit Breakers

NF400-SEP
NF400-HEP
NF400-REP



Type NF400-SEP

Type name		NF400-SEP	NF400-HEP	NF400-REP		
Rated current I _n (Amp.)		200-400 adjustable				
Number of poles		3	4	3		
Rated insulation voltage U _i (V)		690				
Rated short-circuit breaking capacity (kA)	IEC 60947-2 (Icu/Ics)	AC	690V	10/10	10/10	15/10
			500V	30/30	50/50	70/35
			440V	42/42	65/65	125/63
		DC	400V	45/45	70/70	125/63
			230V	85/85	100/100	150/75
			250V	—	—	—

Operating Characteristics

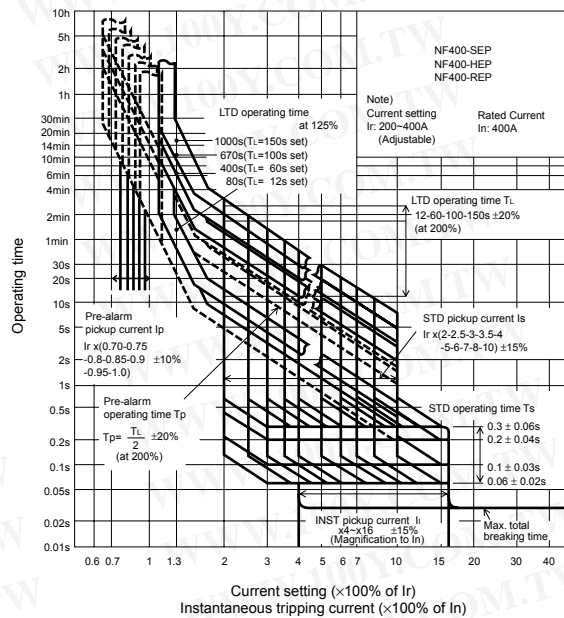

Internal Accessories

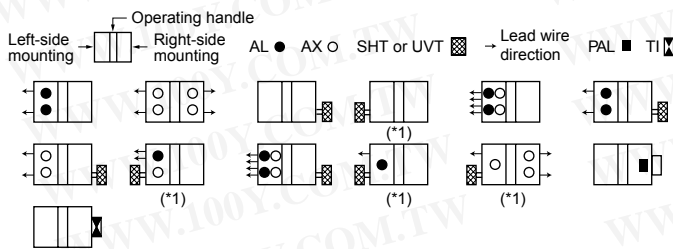

Note: (*) Right-side mounting is standard of SHT and UVT. Specify separately for left-side mounting.
Remark: (1) refer to page 51.

External Accessories

(An order for ☆ should be placed at the same time as an order of circuit breaker main body.)

Accessories	Type name	Reference page	Accessories	Type name	Reference page	
Operating handle	F	F4SPW	61	Terminal cover	66	
	S	S4SP	63			
	V	V4SPWF, V4SPW	60			
Mechanical interlock (MI)	MI-4SP3 (*)	75	Handle lock device	HL	HL-4SP	76
Auxiliary handle (HT)	HT-4SP	76		HL-S	HLS-4SP	
Electrical operation device				☆	67	

Notes: (*) This is for NF400-SEP.
(*)2 The designation depends on the number of poles. Refer to the reference page.

Temperature Characteristics

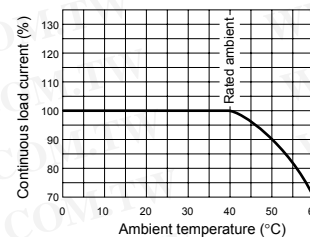

Standard Attached Parts

Front connection	Mounting screw: M6 × 60 (4pcs) Insulating barrier: (2P: 2pcs, 3P: 4pcs, 4P: 6pcs)
Rear connection	Mounting screw: M6 × 72 (4pcs)

Front connection

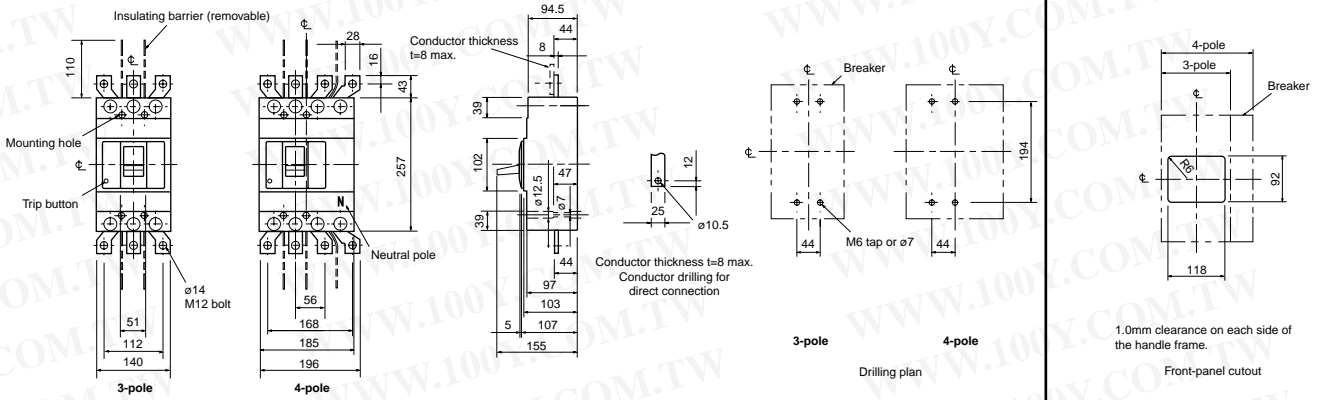

Rear connection

Boring dimensions for rear connection type barriers (3-pole)

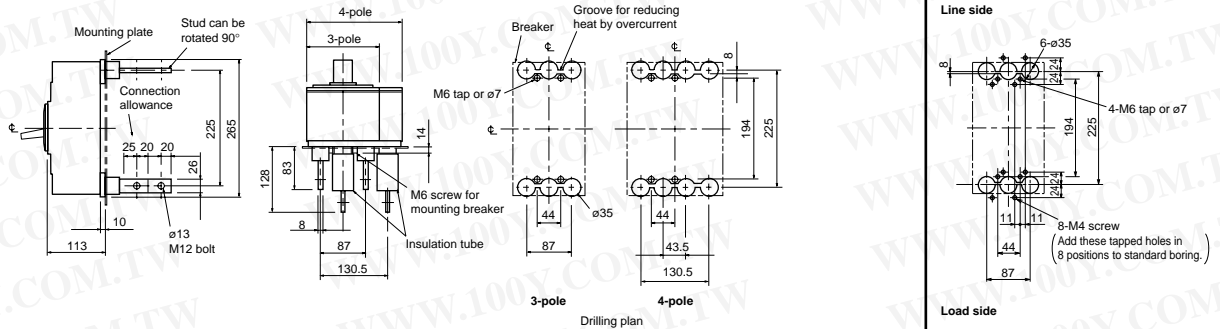

Note: The bore dimensional drawing shows the breaker viewed from the rear.

Plug-in

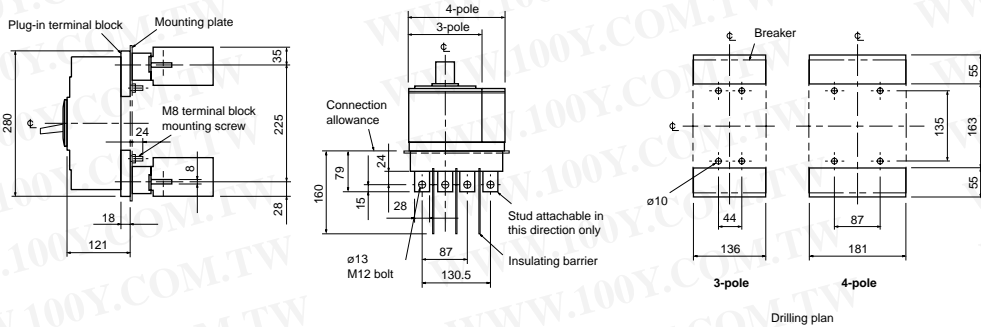

Molded-Case Circuit Breakers

NF400-UEP



Type NF400-UEP

Type name		NF400-UEP		
Rated current In (Amp.)		200-400 adjustable		
Number of poles		3	4	
Rated insulation voltage Ui (V)		690		
Rated short-circuit breaking capacity (kA)	IEC 60947-2 (Icu/Ics)	AC	690V	35/35
			500V	170/170
			440V	200/200
			400V	200/200
			230V	200/200
		DC	250V	—

Operating Characteristics

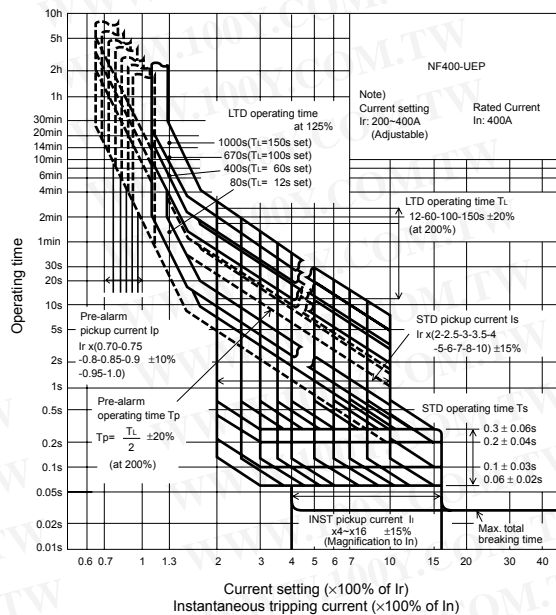

Internal Accessories

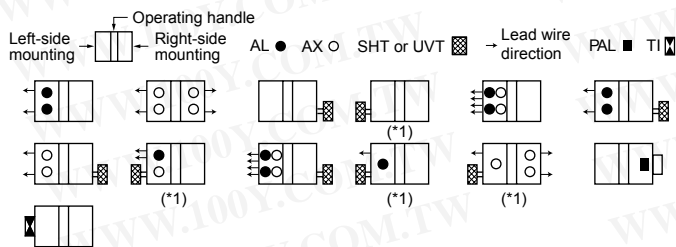

Note: (*) Right-side mounting is standard of SHT and UVT. Specify separately for left-side mounting.

Remark: (1) Specification of 4-pole model is same as that of NF630-UEP. (2) refer to page 51.

Current reducing curve

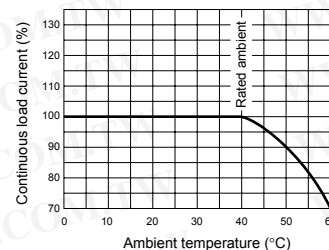

External Accessories

(An order for ☆ should be placed at the same time as an order of circuit breaker main body.)

Accessories	Type name	Reference page	Accessories	Type name	Reference page
Operating handle	F F4UPW (*)	61	Terminal cover	Large (TC-L) TCL-4SP3W (*)	66
	S S4SP	63		Skeleton (TTC)	—
Mechanical interlock (MI)	MI-4SP3 (*)	75		Rear (BTC) BTC-4SP3W (*)	66
Auxiliary handle	(HT) HT-4SP	76	Handle lock device	HL HL-4SP	76
				HL-S HLS-4UP	
			Electrical operation device	☆	67

Note: (*) The designation depends on the number of poles. Refer to the reference page.

Standard Attached Parts

(4-pole models are provided with auxiliary handle.)

Front connection	Mounting screw: M6 × 65 (2pcs), M6 × 162 (2pcs) Insulating barrier: (3P: 4pcs, 4P: 3pcs)
Rear connection	Mounting screw: M6 × 72 (2pcs), M6 × 169 (2pcs)

Front connection

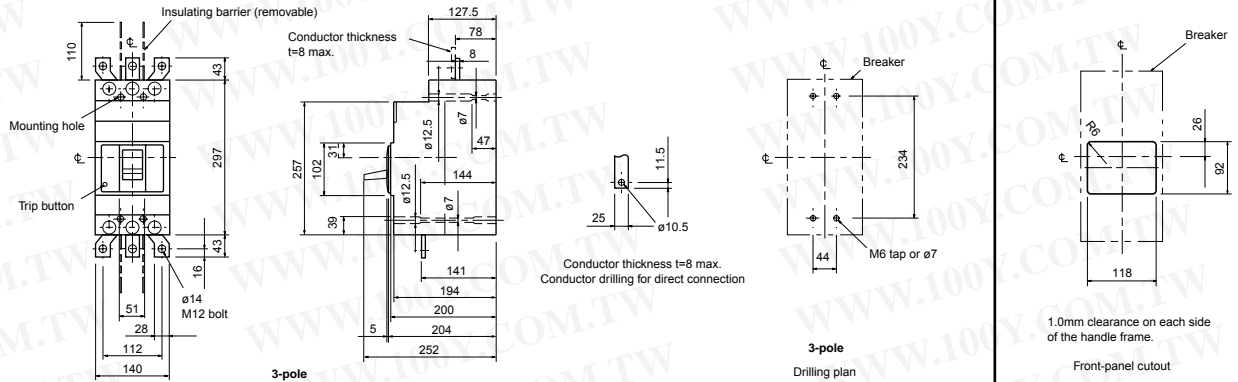

Rear connection

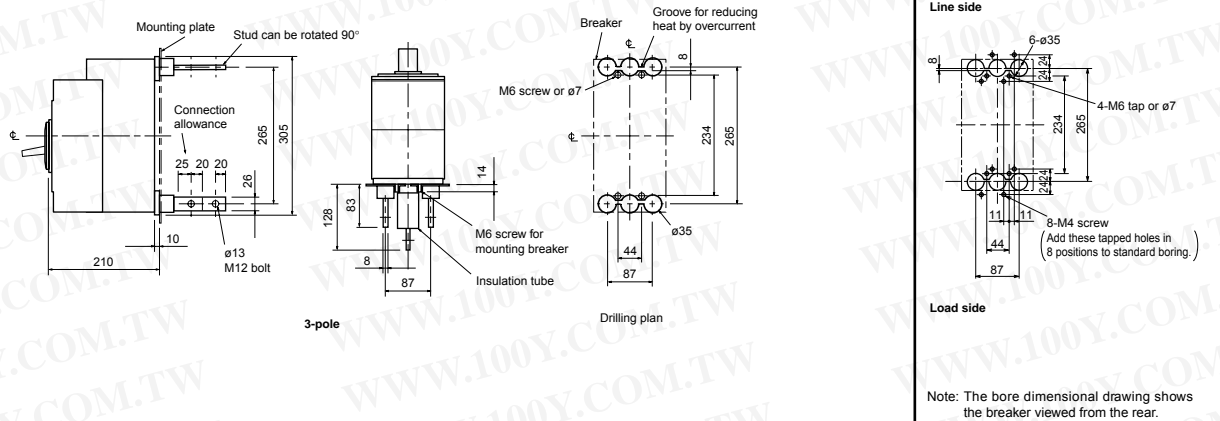

Plug-in

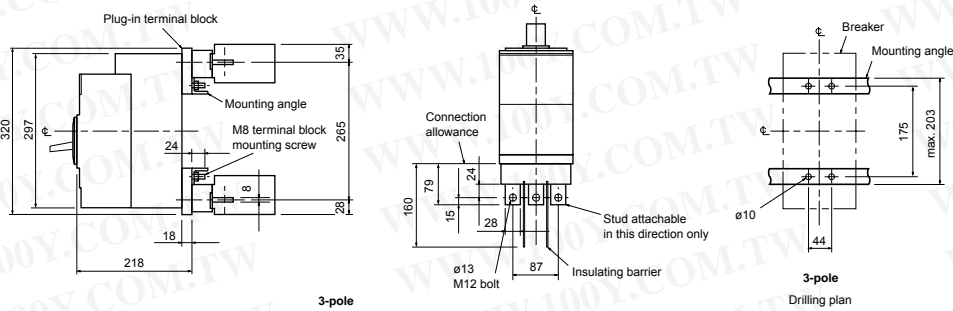

Note (1): Overall dimension of 4-pole model is same as that of 4-pole model of NF630-UEP. Refer to page 32.

Characteristics and Dimensions

12485

Molded-Case Circuit Breakers

NF630-CP
NF630-SP



Type NF630-SP

Type name		NF630-CP			NF630-SP				
Rated current In (Amp.)		500 600 630							
Number of poles		2	3	2	3	4			
Rated insulation voltage Ui (V)		AC			690				
		DC(*1)			250	-	250	-	
Rated short-circuit breaking capacity (kA)	IEC 60947-2 (Icu/Ics)	AC	-			10/10			
			500V			18/9		30/30	
			440V			36/18		42/42	
		400V			36/18		45/45		
		230V			50/25		85/85		
		DC		250V	20/10	-	40/40	-	

Note: (*1) Types of DC specifications can be produced upon request.

Operating Characteristics

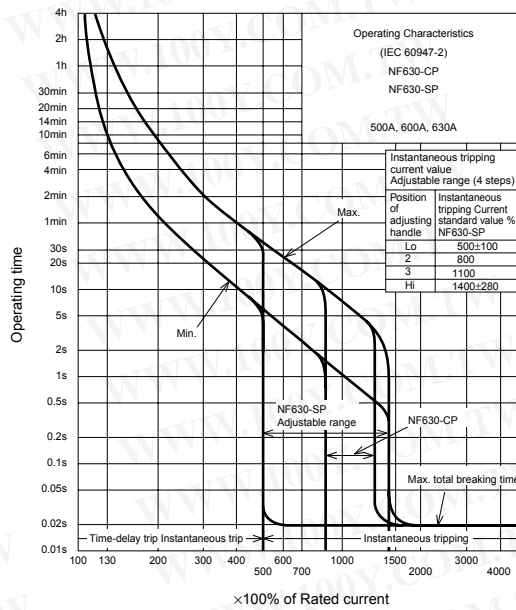

Internal Accessories

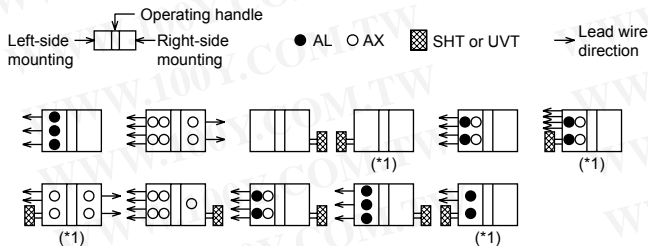

Note: (*1) Right-side mounting is standard of SHT and UVT. Specify separately for left-side mounting.
Remark: (1) refer to page 1.

Ambient Compensating Curve

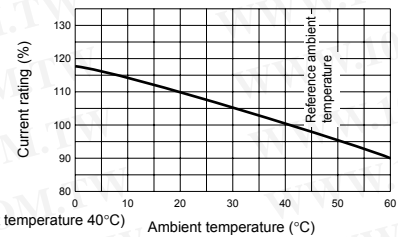

External Accessories

(An order for ☆ should be placed at the same time as an order of circuit breaker main body.)

Accessories	Type name	Reference page	Accessories	Type name	Reference page
Operating handle	F	F6SPW	Terminal cover	Large (TC-L)	TCL-6SP3 (*1)
	S	S4SP		Skeleton (TTC)	TTC-6SP3 (*1)
	V	V6SPWF, V6SPW		Rear (BTC)	BTC-6SP3 (*1)
Mechanical interlock (MI)	MI	MI-6SP3 (*1)	Handle lock device	HL	HL-4SP
Auxiliary handle (HT)	HT	HT-4SP		HL-S	HLS-6SP
			Electrical operation device	☆	67

Note: (*1) The designation depends on the number of poles. Refer to the reference page.

Standard Attached Parts

(4-pole models are provided with auxiliary handle.)

Front connection	Mounting screw: M6 × 35 (4pcs) Insulating barrier: (2P: 1pc, 3P: 2pcs, 4P: 3pcs)
Rear connection	Mounting screw: M6 × 40 (4pcs)

Front connection

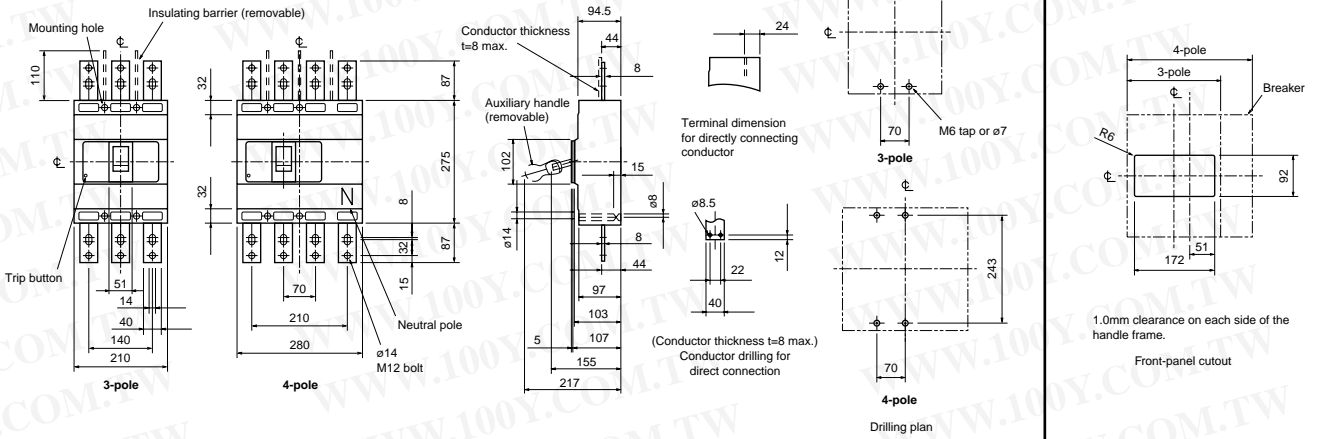

Rear connection

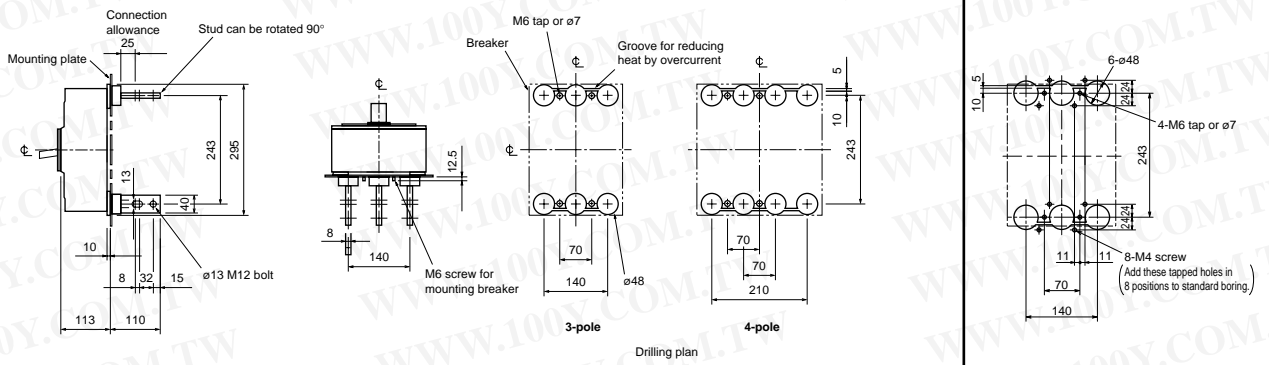

Boring dimensions for rear connection type barriers (3-pole)

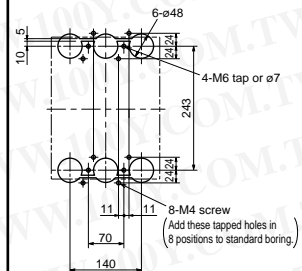

Plug-in

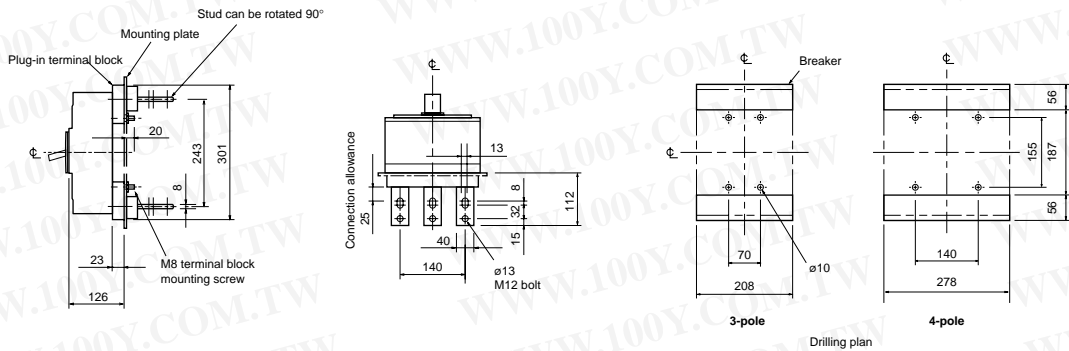

Remark: (1) 2-pole models are 3-pole models with the central pole removed.

Characteristics and Dimensions

12485

Molded-Case Circuit Breakers

NF630-SEP
NF630-HEP
NF630-REP



Type NF630-SEP

Type name		NF630-SEP	NF630-HEP	NF630-REP
Rated current In (Amp.)		300-630 adjustable		
Number of poles		3	4	3
Rated insulation voltage Ui (V)		AC 690	690	690
Rated short-circuit breaking capacity (kA)	IEC 60947-2 (Icu/Ics)	AC 690V	10/10	15/15
		500V	30/30	50/50
		440V	42/42	65/65
		400V	45/45	70/70
		230V	85/85	100/100
		DC 250V	—	—

Operating Characteristics

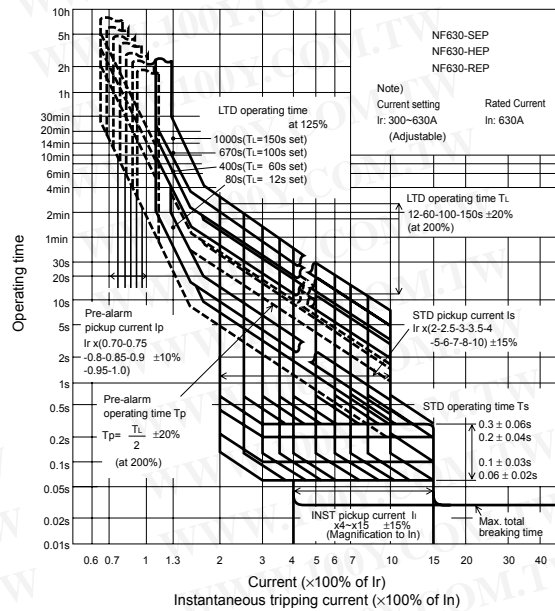

Internal Accessories

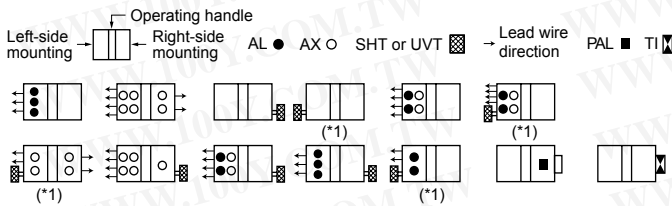

Note: (*1) Right-side mounting is standard of SHT and UVT. Specify separately for left-side mounting.
Remark: (1) refer to page 51.

Temperature Characteristics

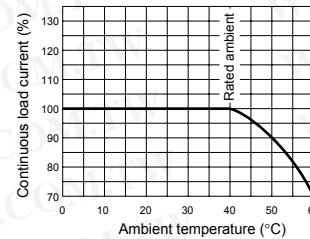

External Accessories

(An order for ☆ should be placed at the same time as an order of circuit breaker main body.)

Accessories	Type name	Reference page	Accessories	Type name	Reference page
Operating handle	F F6SPW	61	Terminal cover	Large (TC-L) TCL-6SP3 (*1)	66
	S S4SP	63		Skeleton (TTC) TTC-6SP3 (*1)	
	V V6SPWF, V6SPW	60		Rear (BTC) BTC-6SP3 (*1)	
Mechanical interlock (MI)	MI-6SP3 (*1)	75	Handle lock device	HL HL-4SP	76
Auxiliary handle (HT)	HT-4SP	76		HL-S HLS-6SP	
Electrical operation device				☆	67

Note: (*1) The designation depends on the number of poles. Refer to the reference page.

Standard Attached Parts

(4-pole models are provided with auxiliary handle.)

Front connection	Mounting screw: M6 × 35 (4pcs) Insulating barrier: (3P: 2pcs, 4P: 3pcs)
Rear connection	Mounting screw: M6 × 40 (4pcs)

Front connection

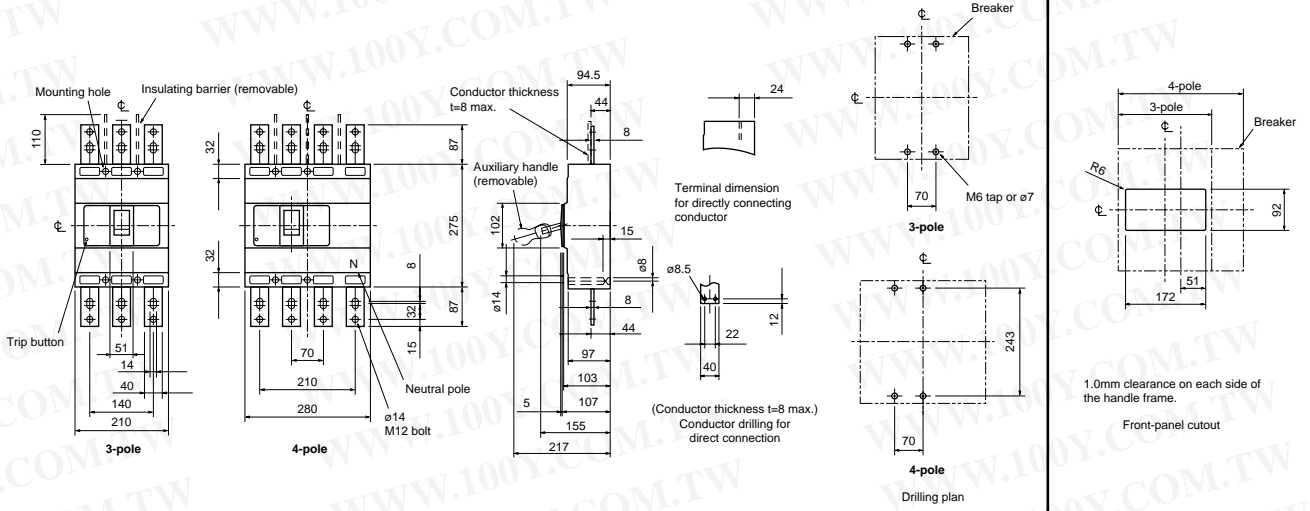

Rear connection

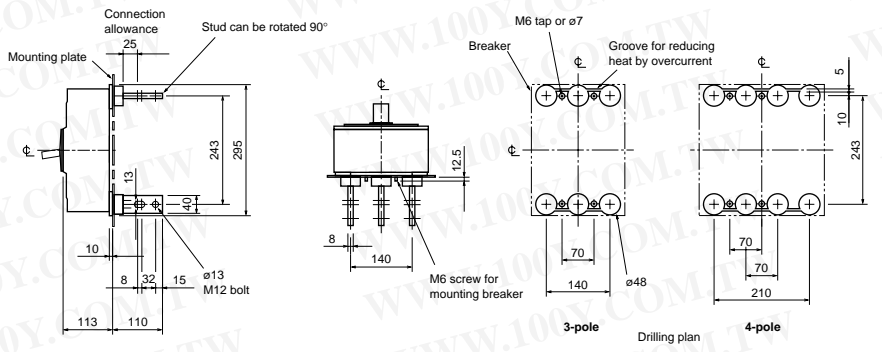

Boring dimensions for rear connection type barriers (3-pole)

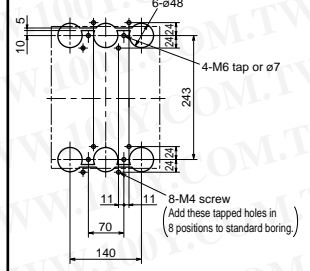

Plug-in

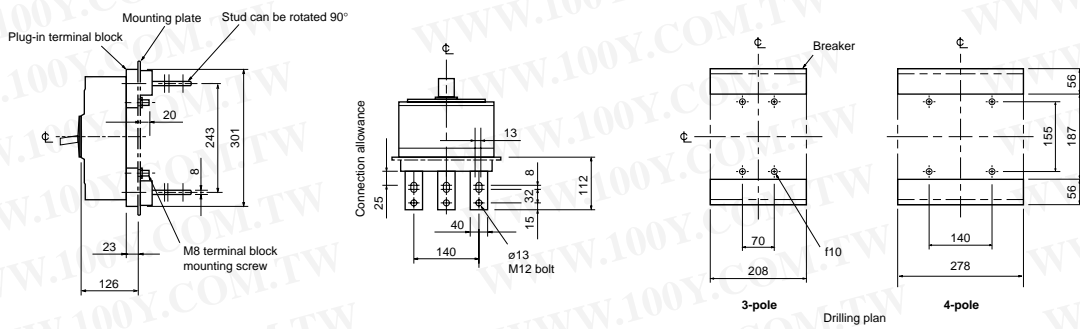

Characteristics and Dimensions

Molded-Case Circuit Breakers

NF630-UEP



Type NF630-UEP

Type name		NF630-UEP	
Rated current In (Amp.)		300-630 adjustable	
Number of poles		3	4
Rated insulation voltage Ui (V)		AC 690	
Rated short-circuit breaking capacity (kA)	IEC 60947-2 (Icu/Ics)	AC	690V 35/35
			500V 170/170
			440V 200/200
			400V 200/200
			230V 200/200
	DC	250V	—

Operating Characteristics

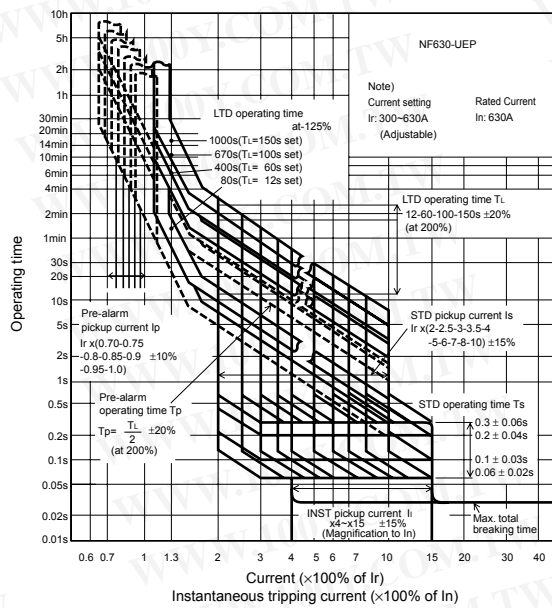

Internal Accessories

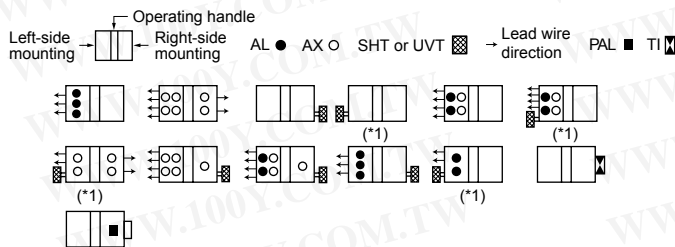

Note: (*1) Right-side mounting is standard of SHT and UVT. Specify separately for left-side mounting.
Remark: (1) refer to page 51.

Temperature Characteristics

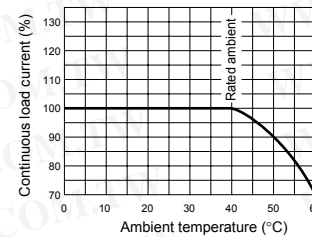

External Accessories

(An order for ☆ should be placed at the same time as an order of circuit breaker main body.)

Accessories	Type name	Reference page	Accessories	Type name	Reference page
Operating handle	F F6UPW(*1)	61	Terminal cover	Large (TC-L) TCL-6UP3 (*1)	66
	S S4SP	63		Skeleton (TTC)	—
Mechanical interlock (MI)	MI-6SP3 (*1)	75		Rear (BTC) BTC-6SP3 (*1)	66
Auxiliary handle (HT)	HT-4SP	76	Handle lock device	HL HL-4SP	76
				HL-S HLS-6UP	
Electrical operation device				☆	67

Note: (*1) The designation depends on the number of poles. Refer to the reference page.

Standard Attached Parts

(4-pole models are provided with auxiliary handle.)

Front connection	Mounting screw: 3P: M6 × 35, M6 × 132 (2pcs each) 4P: M6 × 35 (3pcs), M6 × 132 (2pcs) Insulating barrier: (3P: 2pcs, 4P: 3pcs)
Rear connection	Mounting screw: 3P: M6 × 40, M6 × 137 (2pcs each) 4P: M6 × 40 (3pcs), M6 × 137 (2pcs)

Front connection

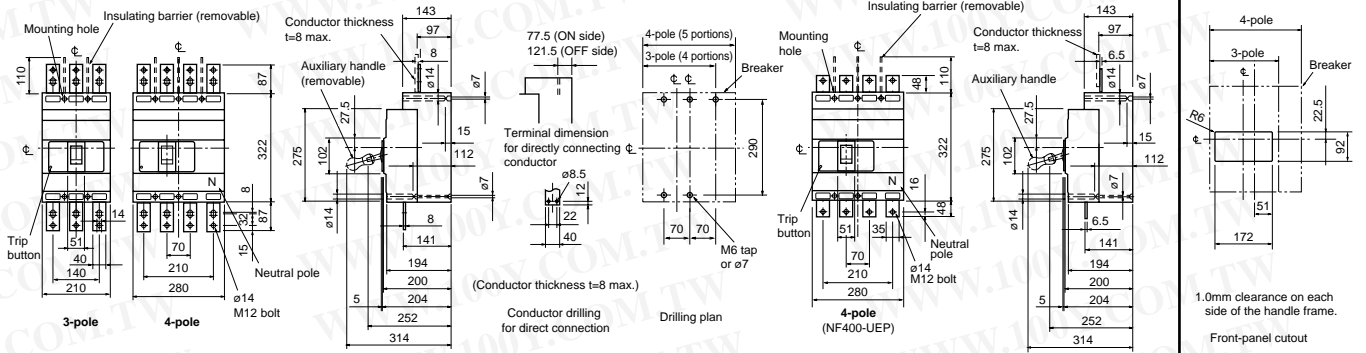

Rear connection

Boring dimensions for rear connection type barriers (3-pole)

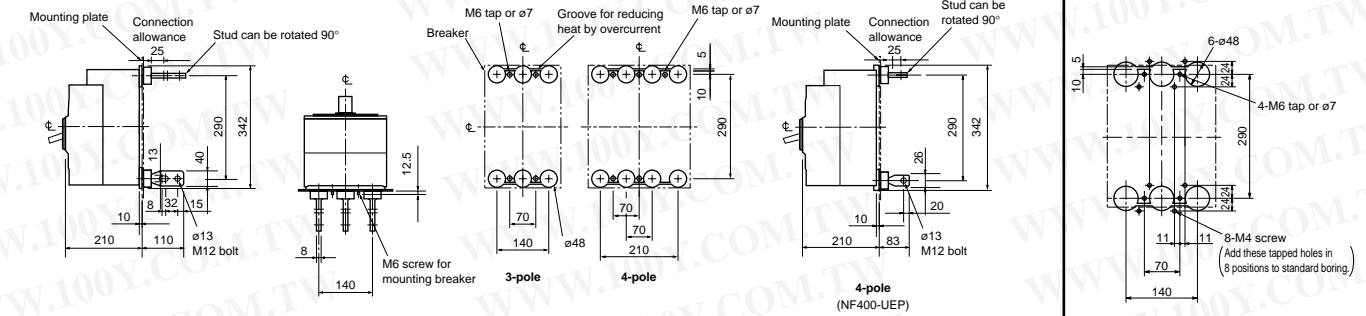

Plug-in

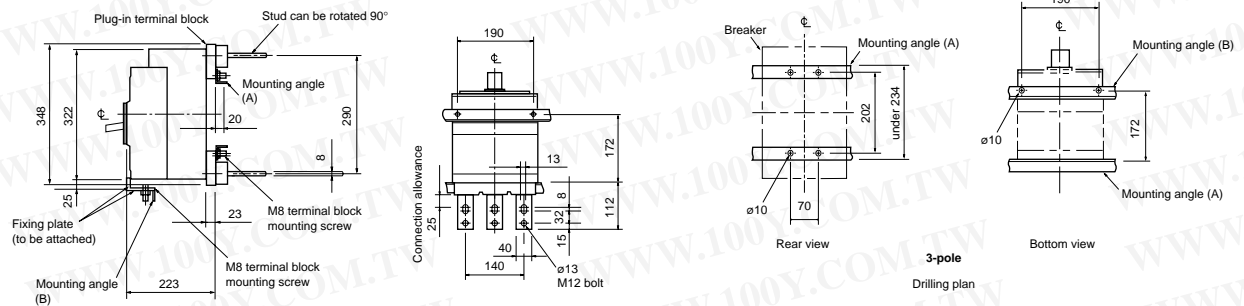

Characteristics and Dimensions

Molded-Case Circuit Breakers

NF800-CEP
NF800-SEP
NF800-HEP
NF800-REP



Type NF800-SEP

Type name	NF800-CEP	NF800-SEP	NF800-HEP	NF800-REP		
Rated current In (Amp.)	400-800 adjustable					
Number of poles	3	3	4	3		
Rated insulation voltage Ui (V)	600	690	690	690		
Rated short-circuit breaking capacity (kA) IEC 60947-2 (Icu/Ics)	AC	690V	10/10	15/15	20/15	
		500V	18/9	30/30	50/50	70/35
		440V	36/18	42/42	65/65	125/63
		400V	36/18	45/45	70/70	125/63
		230V	50/25	85/85	100/100	150/75
	DC	250V	—	—	—	

Operating Characteristics

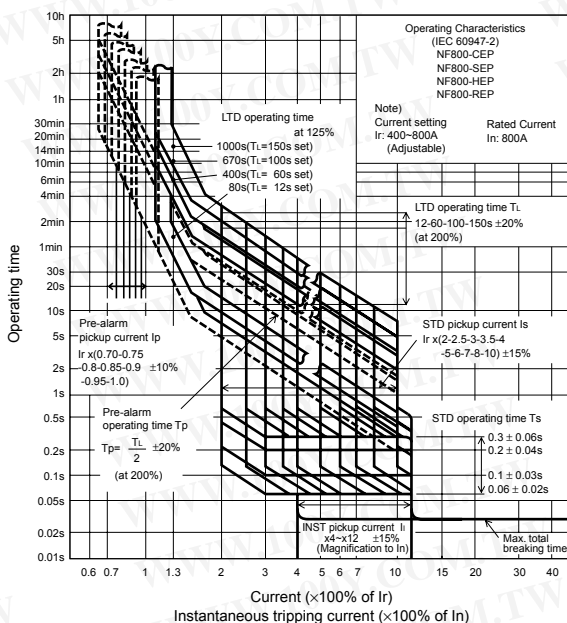

Internal Accessories

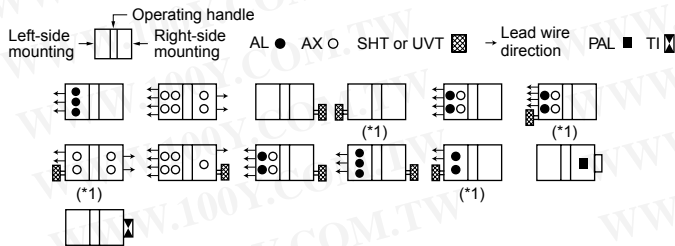

Note: (*1) Right-side mounting is standard of SHT and UVT. Specify separately for left-side mounting.
Remark: (1) refer to page 51.

External Accessories

(An order for ☆ should be placed at the same time as an order of circuit breaker main body.)

Accessories	Type name	Reference page	Accessories	Type name	Reference page
Operating handle	F F6SPW	61	Large (TC-L)	TCL-6SP3 (*1)	66
	S S4SP	63	Skeleton (TTC)	TTC-6SP3 (*1)	
	V V6SPWF, V6SPW	60	Rear (BTC)	BTC-6SP3 (*1)	
Mechanical interlock (MI)	MI-6SP3 (*1)	75	Handle lock device	HL HL-4SP	76
Auxiliary handle (HT)	HT-4SP	76	Handle lock device	HL-S HLS-6SP	
			Electrical operation device	☆	67

Note: (*1) The designation depends on the number of poles. Refer to the reference page.

Current Reducing Curve

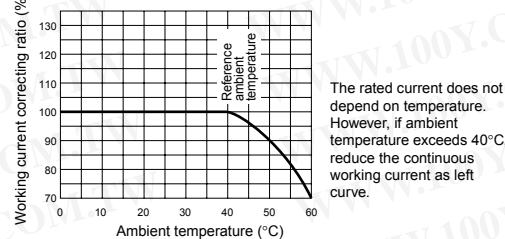

Standard Attached Parts

(4-pole models are provided with auxiliary handle.)

Front connection	Mounting screw: M6 × 35 (4pcs) Insulating barrier: (3P: 2pcs, 4P: 3pcs)
Rear connection	Mounting screw: M6 × 40 (4pcs)

Front connection

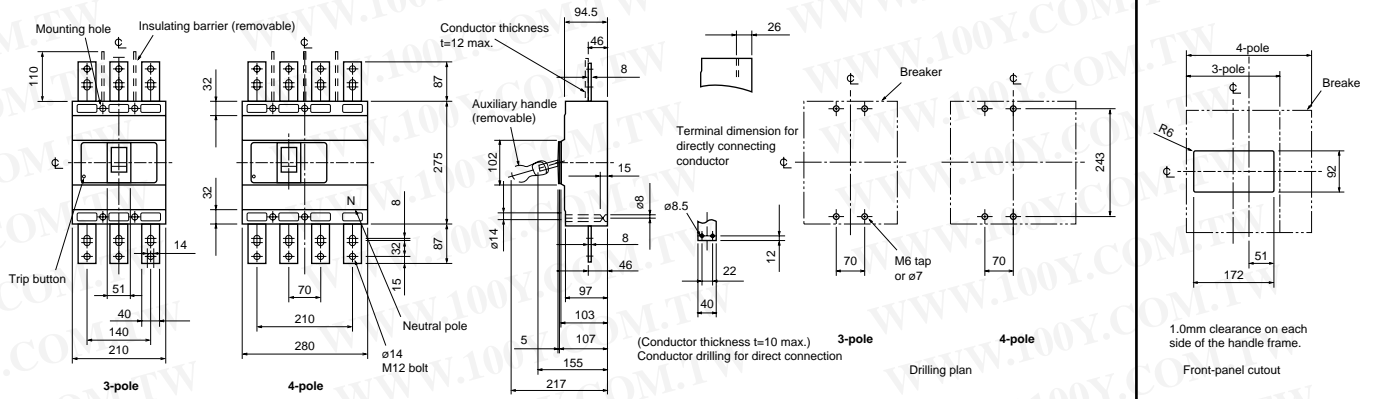

Rear connection

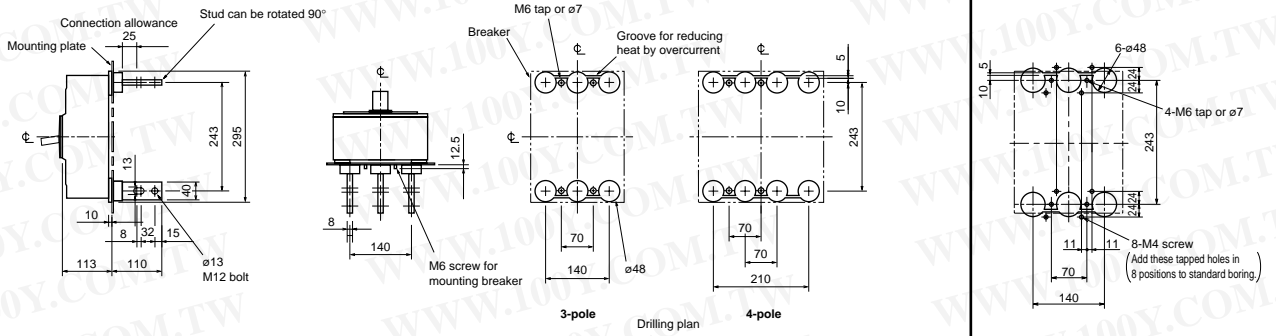

Plug-in

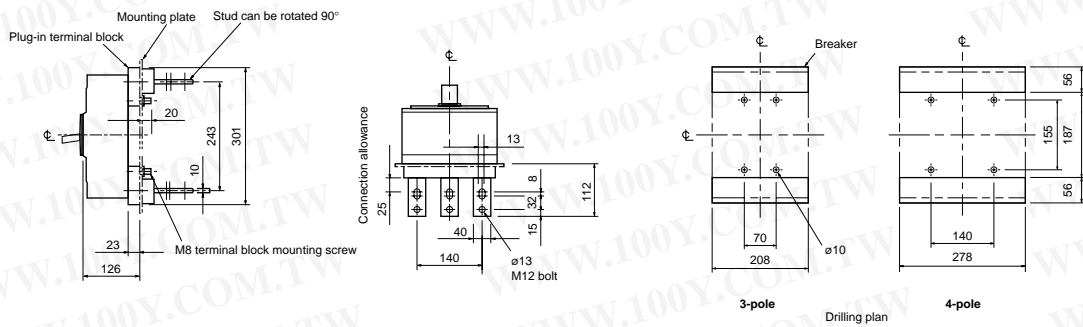

Characteristics and Dimensions

12485

Molded-Case Circuit Breakers

NF800-SDP



Type NF800-SDP

Type name		NF800-SDP	
Rated current In (Amp.)		(700), 800	
Number of poles		2	
Rated insulation voltage Ui (V)		DC	250
Rated short-circuit breaking capacity (kA)	IEC 60947-2 (Icu/Ics)	DC	250V
	Time constant not larger than 10msec		

Operating Characteristics

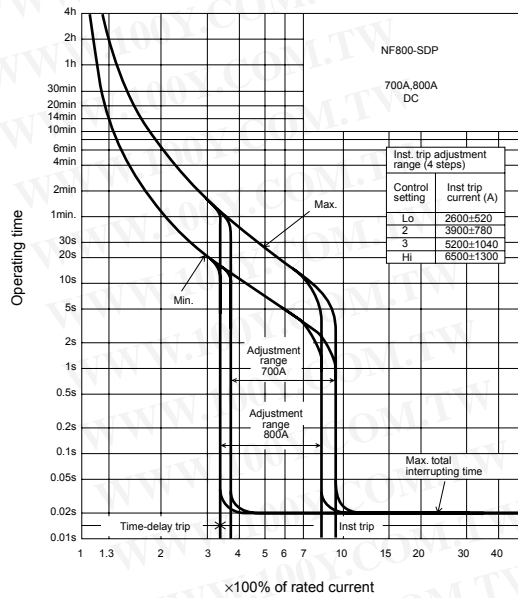

Internal Accessories

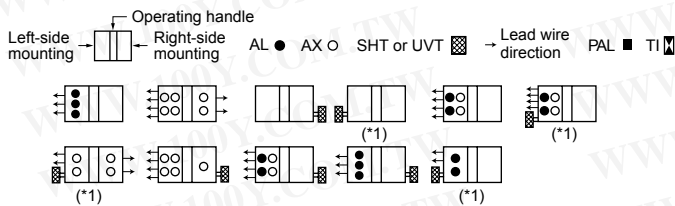

Note: (*) Right-side mounting is standard of SHT and UVT. Specify separately for left-side mounting.
Remark: (1) refer to page 51.

Ambient Compensating Curve

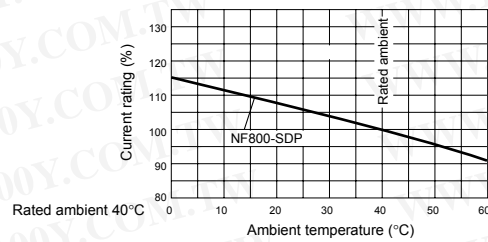

External Accessories

(An order for ☆ should be placed at the same time as an order of circuit breaker main body.)

Accessories	Type name	Reference page	Accessories	Type name	Reference page	
Operating handle	F F6SPW	61	Terminal cover	Large (TC-L) TCL-6SP3 (*)	66	
	S S4SP	63		Skeleton (TTC) TTC-6SP3 (*)		
	V V6SPWF, V6SPW	60		Rear (BTC) BTC-6SP3 (*)		
Mechanical interlock (MI)	MI-6SP3 (*)	75	Handle lock device	HL HL-4SP	76	
Auxiliary handle (HT)	HT-4SP	76		HL-S HLS-6SP		
				Electrical operation device	☆	67

Note: (*) The designation depends on the number of poles. Refer to the reference page.

Standard Attached Parts

(4-pole models are provided with auxiliary handle.)

Front connection	Mounting screw: M6 × 35 (4pcs) Insulating barrier: (2P: 1pc, 3P: 2pcs, 4P: 3pcs)
Rear connection	Mounting screw: M6 × 40 (4pcs)

Front connection

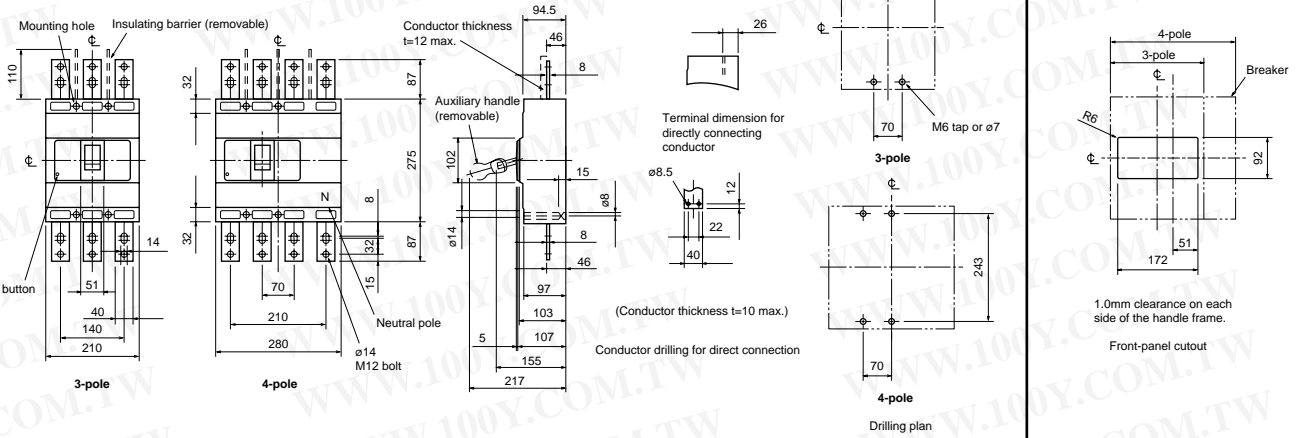

Rear connection

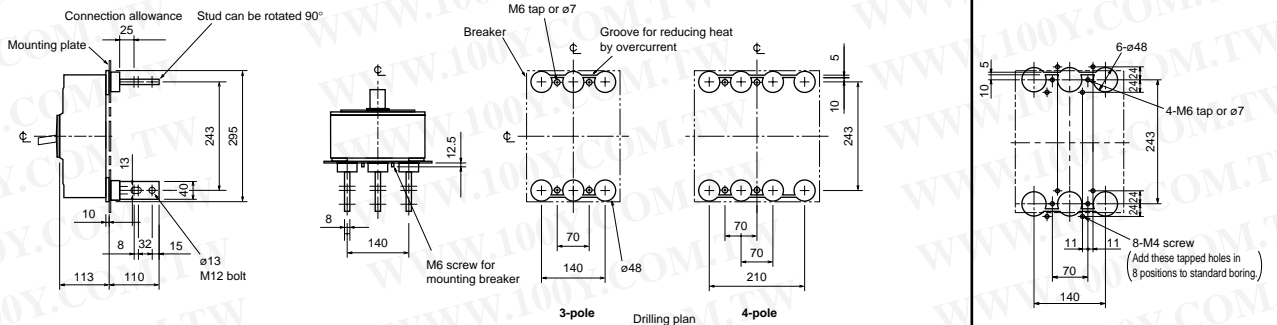

Plug-in

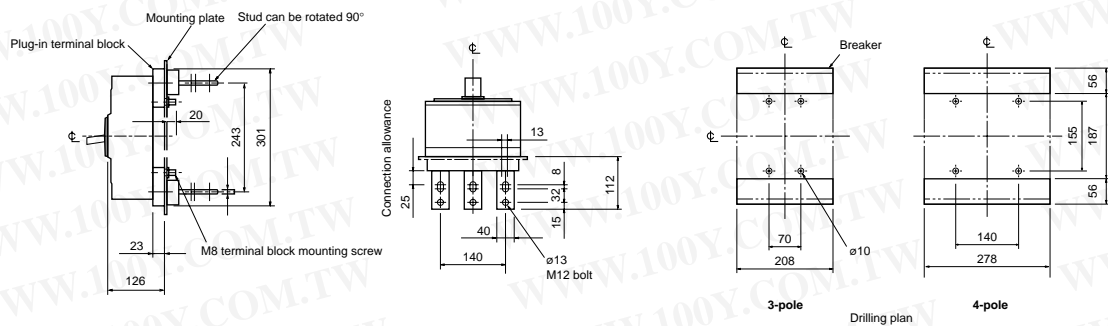

Remarks: (1) Standard specification of NF800-SDP is 2-pole model. 3-pole and 4-pole models are available for DC special voltage.
 (2) 2-pole models are 3-pole models with the central pole removed.

Characteristics and Dimensions

Molded-Case Circuit Breakers

NF800-UEP



Type NF800-UEP

Type name		NF800-UEP		
Rated current In (Amp.)		400-800 adjustable		
Number of poles		3	4	
Rated insulation voltage Ui (V)		690		
Rated short-circuit breaking capacity (kA)	IEC 60947-2 (Icu/Ics)	AC	690V	35/35
			500V	170/170
			440V	200/200
			400V	200/200
			230V	200/200
		DC	250V	—

Operating Characteristics

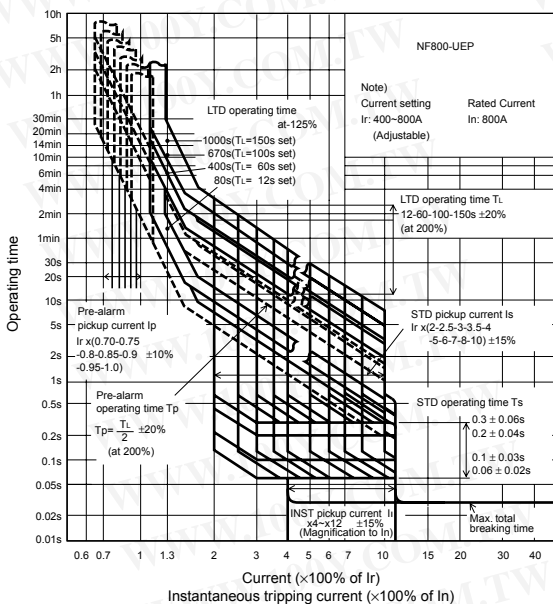

Internal Accessories

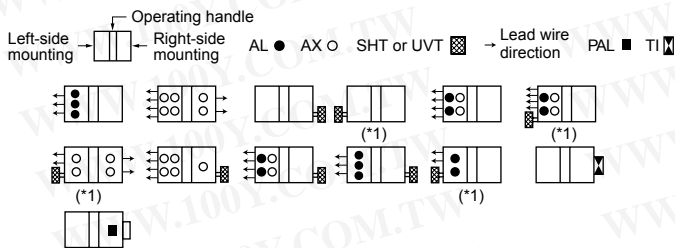

Note: (*1) Right-side mounting is standard of SHT and UVT. Specify separately for left-side mounting.
 Remark: (1) refer to page 51.

Current reducing curve

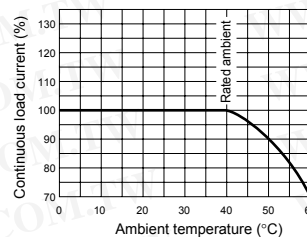

External Accessories

(An order for ☆ should be placed at the same time as an order of circuit breaker main body.)

Accessories	Type name	Reference page	Accessories	Type name	Reference page	
Operating handle	F	F6UPW(*1)	61	Large (TC-L)	TCL-6UP3 (*1)	66
	S	S4SP	63	Skeleton (TTC)	—	—
	V	—	—	Rear (BTC)	BTC-6SP3 (*1)	66
Mechanical interlock (MI)	MI-6SP3 (*1)	75	Handle lock device	HL	HL-4SP	76
Auxiliary handle (HT)	HT-4SP	76		HL-S	HLS-6UP	
			Electrical operation device	☆	67	

Note: (*1) The designation depends on the number of poles. Refer to the reference page.

Standard Attached Parts

(4-pole models are provided with auxiliary handle.)

Front connection	Mounting screw: 3P: M6 × 35, M6 × 132 (2pcs each)
	4P: M6 × 35 (3pcs), M6 × 132 (2pcs) Insulating barrier: (3P: 2pcs, 4P: 3pcs)
Rear connection	Mounting screw: 3P: M6 × 40, M6 × 137 (2pcs each)
	4P: M6 × 40 (3pcs), M6 × 137 (2pcs)

Front connection

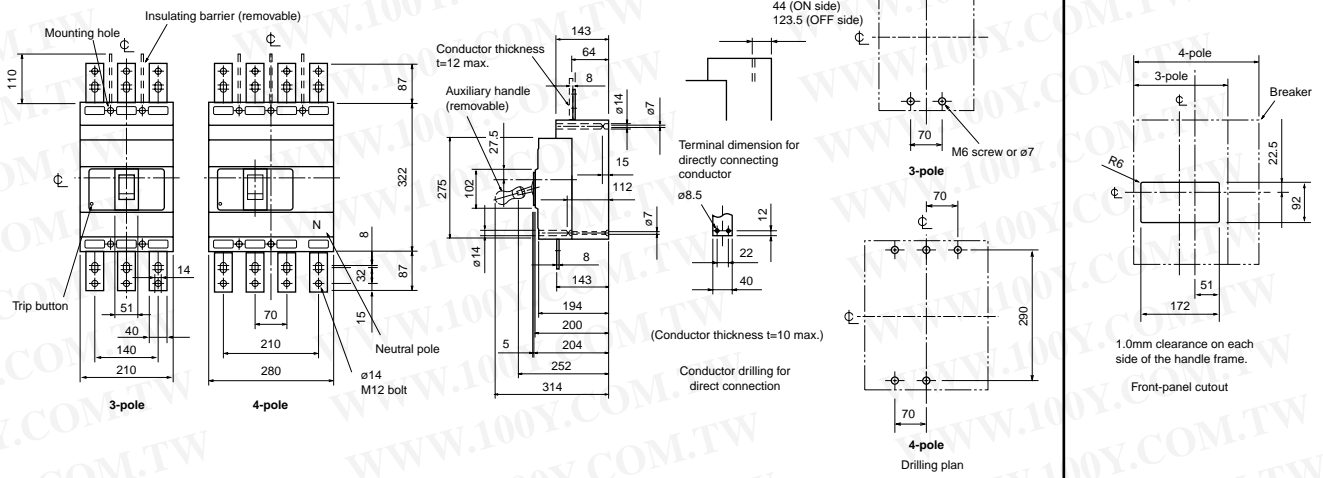

Rear connection

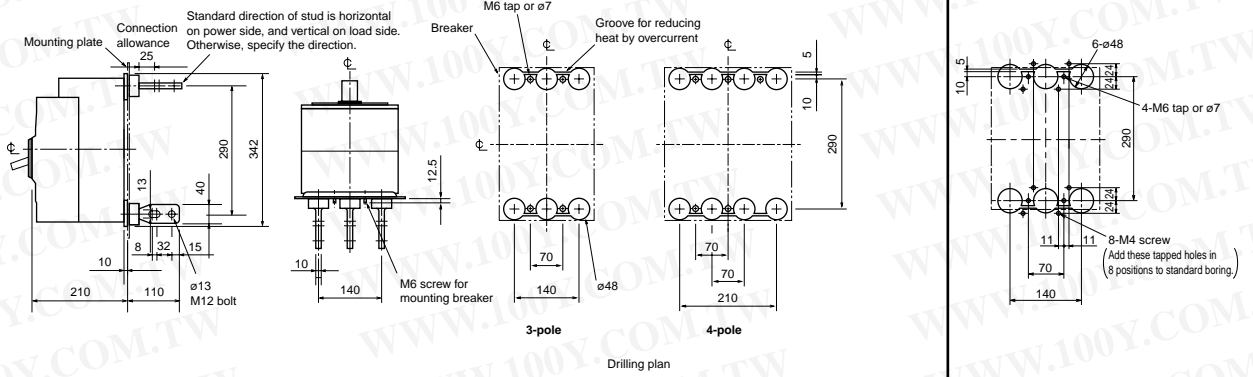

Characteristics and Dimensions

12485

Molded-Case Circuit Breakers

NF1000-SS
NF1250-SS



Type NF1000-SS

Type name		NF1000-SS		NF1250-SS	
Rated current In (Amp.)		Adjustable	500 600 700 800 900 1000	Adjustable	600 700 800 1000 1200 1250
Number of poles		3	4	3	4
Rated insulation voltage Ui (V)		AC 660		DC 660	
Rated short-circuit breaking capacity (kA)	IEC 60947-2 (Icu/lcs)	AC	690V	25/13	25/13
			500V	65/33	65/33
			440V	85/43	85/43
			400V	85/43	85/43
			230V	125/63	125/63
		DC	250V	—	—

Operating Characteristics

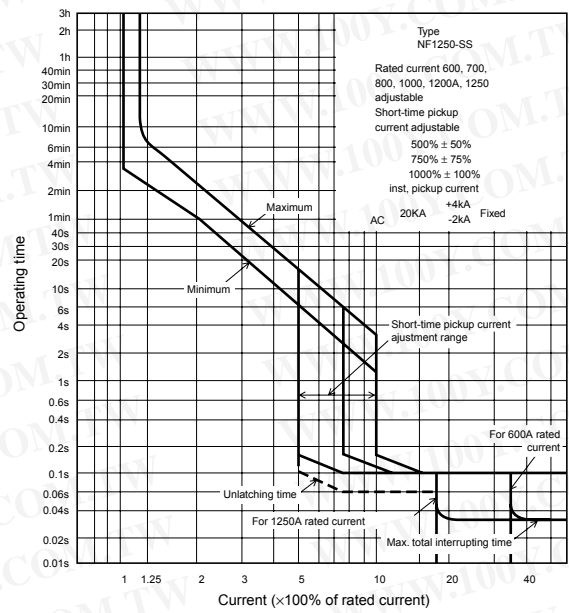
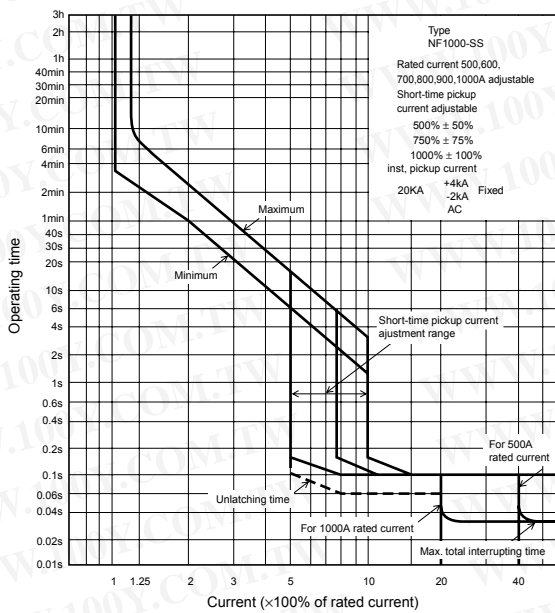

Internal Accessories

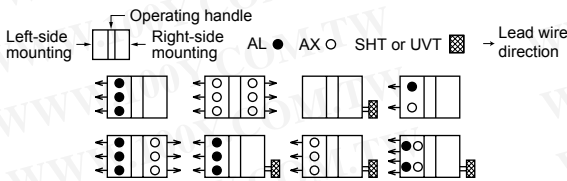

Remark: (*1) refer to page 51.

Current reduction curve

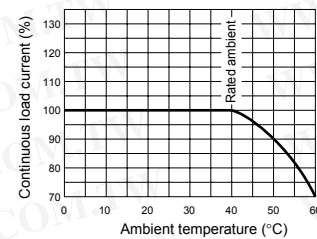

External Accessories

(An order for ☆ should be placed at the same time as an order of circuit breaker main body.)

Accessories	Type name	Reference page	Accessories	Type name	Reference page
Operating handle	F	F100 (*1)	Auxiliary handle	HT-10SS	76
	S	S100	Handle lock (HL)	☆	
Mechanical interlock (MI)	(MI)	MI-10SS3 (*1)	Large terminal cover (TC-L)	TCL-10SS3 (*1)	66
			Electrical operation device	☆	

Note: (*1) The designation depends on the number of poles. Refer to the reference page.

Rated current set available value (A)

NF1000-SS	500, 600, 700, 800, 900, 1000
NF1250-SS	600, 700, 800, 1000, 1200, 1250

Rated current can be set to 6 steps and 5 steps with screw method.

Standard Attached Parts

Front connection	Mounting screw: M8 × 40 (4pcs) Insulating barrier: (3P: 2pcs, 4P: 3pcs) Auxiliary handle: (1pc)
Rear connection	Mounting screw: M8 × 40 (4pcs) Insulating barrier: (3P: 2pcs, 4P: 4pcs) Auxiliary handle: (1pc)

Front connection

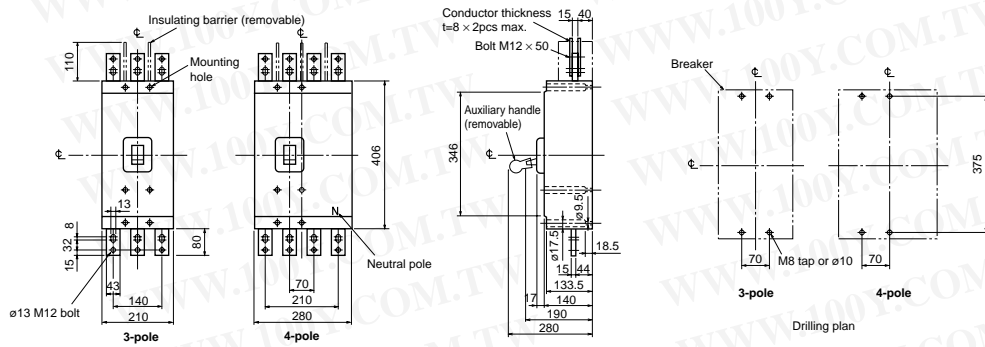

Rear connection

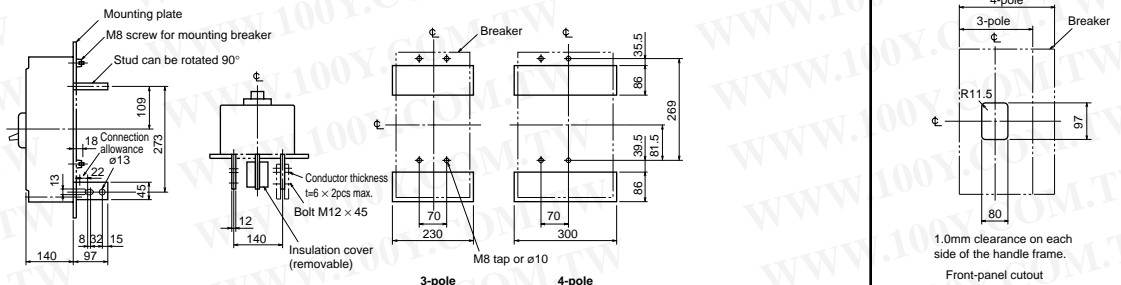

Plug-in

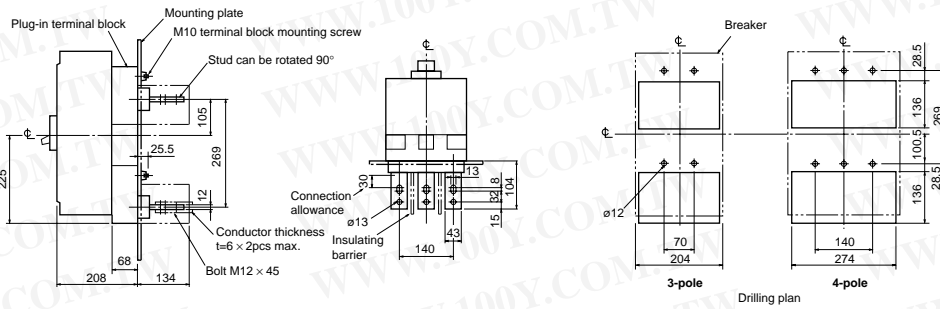

Draw-out

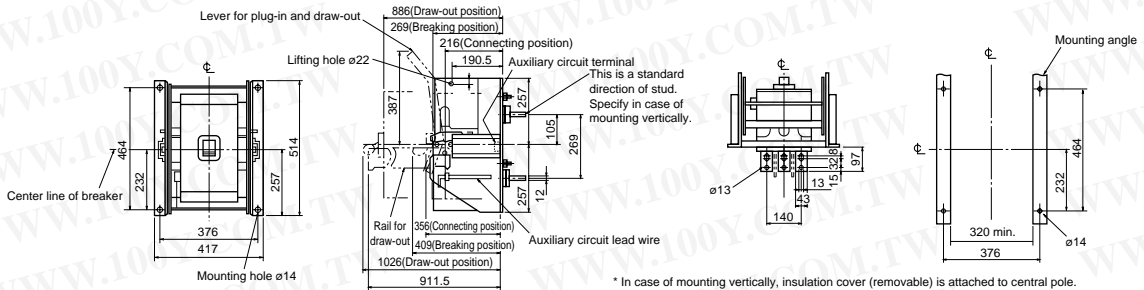

Remark: (1) Draw-out is available only for 3-pole models of NF1000-SS and NF1250-SS.

Characteristics and Dimensions

12485

Molded-Case Circuit Breakers

NF1000-SSD
NF1250-SSD



Type NF1000-SSD

Type name		NF1000-SSD	NF1250-SSD
Rated current In (Amp.)		1000	1250
Number of poles		2	2
Rated insulation voltage Ui (V)		DC 250	250
Rated short-circuit breaking capacity (kA) IEC 60947-2 (Icu/Ics)	DC 250V	40/20	40/20
Time constant not larger than 10msec			

Operating Characteristics (page 000)

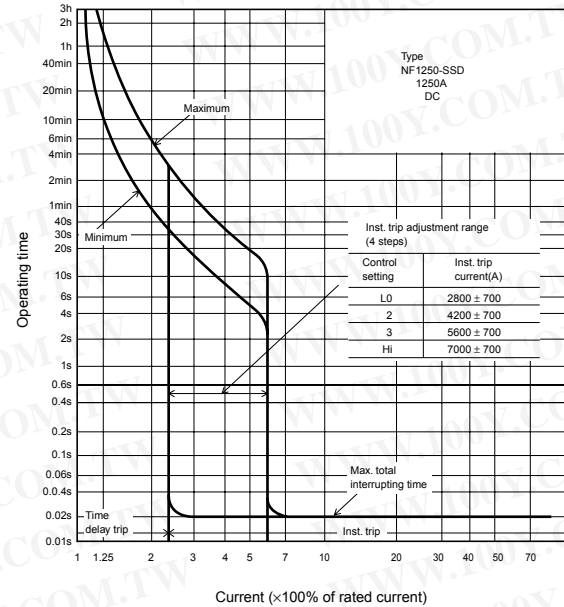
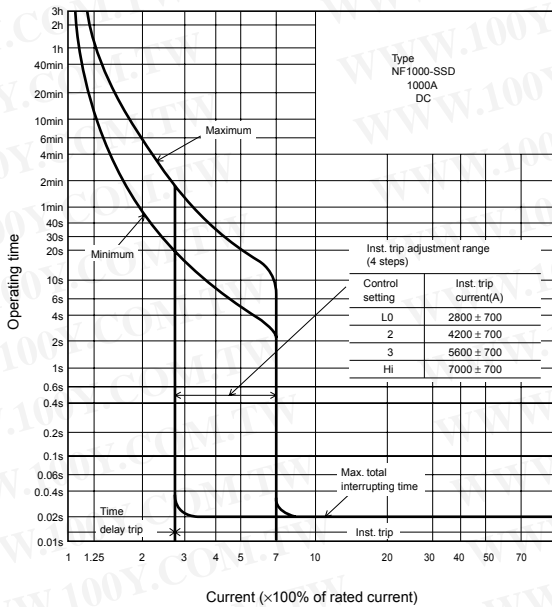

Internal Accessories

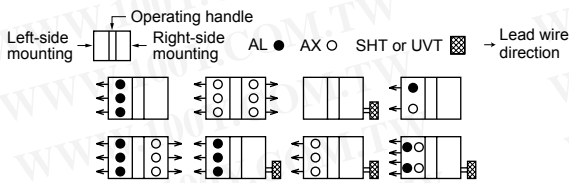

Remark: (1) refer to page 1.

Ambient Compensating Curve

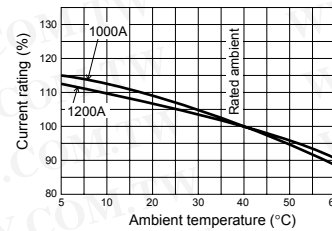

External Accessories

(An order for ☆ should be placed at the same time as an order of circuit breaker main body.)

Accessories	Type name	Reference page	Accessories	Type name	Reference page
Operating handle	F	F100 (*1)	Auxiliary handle	HT-10SS	76
	S	S100	Handle lock (HL)	☆	
Mechanical interlock (MI)	MI-10SS3 (*1)	75	Large terminal cover (TC-L)	TCL-10SS3 (*1)	66
			Electrical operation device	☆	67

Notes: (*1) The designation depends on the number of poles. Refer to the referenc page.

Standard Attached Parts

Front connection	Mounting screw: M8 × 40 (4pcs) Insulating barrier: (2P: 1pcs, 3P: 2pcs, 4P: 3pcs) Auxiliary handle: (1pc)
Rear connection	Mounting screw: M8 × 40 (4pcs) Insulating cover (3P: 2pcs, 4P: 4pcs) Auxiliary handle: (1pc)

Front connection

Outside dimensions are same as those of NF1000-SS and NF1250-SS.

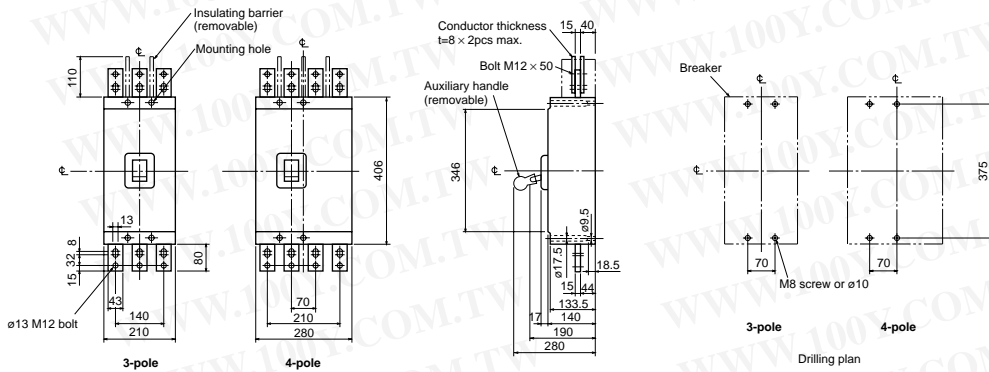

Rear connection

Outside dimensions are different from those of NF1000-SS and NF1250-SS.

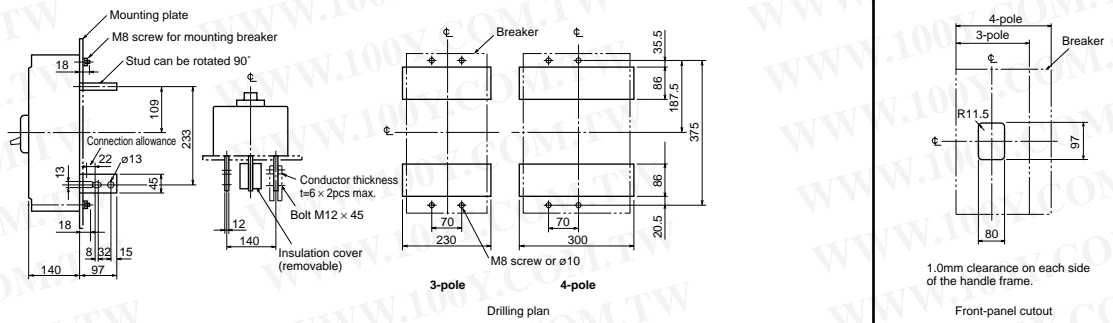

1.0mm clearance on each side of the handle frame.
Front-panel cutout

Plug-in

Outside dimensions are different from those of NF1000-SS and NF1250-SS.

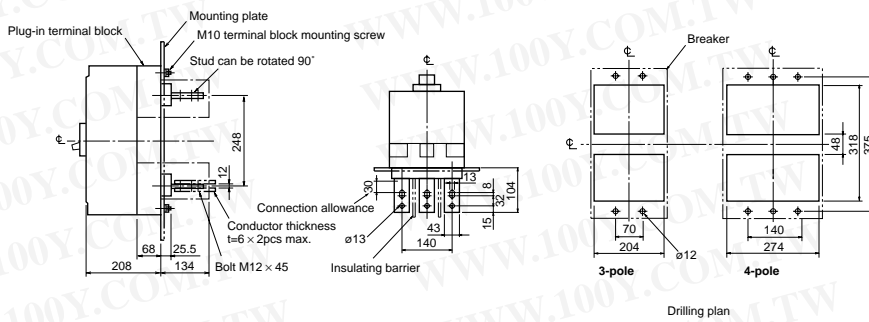

Remarks: (1) Standard specifications of NF1000-SSD and NF1250-SSD are 2-pole models. 3-pole and 4-pole models are for DC special voltage.
(2) 2-pole models are 3-pole models with the central pole removed.

Characteristics and Dimensions

12485

Molded-Case Circuit Breakers

NF1250-UR



Type NF1250-UR

Type name		NF1250-UR	
Rated current In (Amp.)		Adjustable 600, 700, 800, 1000, 1200, 1250	
Number of poles		3	4
Rated insulation voltage Ui (V)		690V	
Rated short-circuit breaking capacity (kA)	IEC 60947-2 (Icu/Ics)	AC	690V
			500V
			440V
			400V
			230V
	DC	250V	—

Operating Characteristics

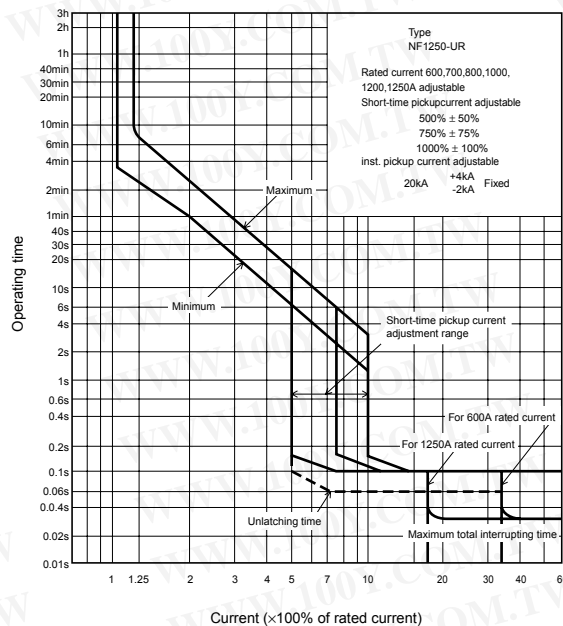

Internal Accessories

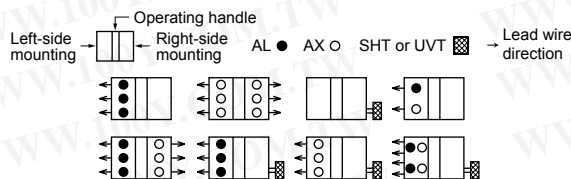

Current reducing curve

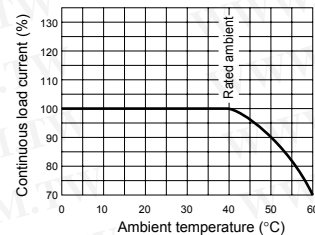

External Accessories

(An order for ☆ should be placed at the same time as an order of circuit breaker main body.)

Accessories	Type name	Reference page	Accessories	Type name	Reference page
Operating handle	F	F120UR (*1)	Auxiliary handle	HT-10SS	76
	S	S100	Handle lock (HL)	☆	
Mechanical interlock (MI)	MI-12UR3 (*1)	75	Large terminal cover (TC-L)	TCL-12UR3 (*1)	66
			Electrical operation device	☆	67

Notes: (*1) The designation depends on the number of poles. Refer to the reference page.

Rated current set available value (A)

NF1250-UR 600, 700, 800, 1000, 1250

Rated current can be set to 5 steps with screw method.

Standard Attached Parts

Front connection	Mounting screw: M8 × 45 (4pcs) Insulating barrier: (3P: 2pcs, 4P: 3pcs) Auxiliary handle: (1pc)
Rear connection	Mounting screw: M8 × 45 (4pcs) Insulating cover: (3P: 2pcs, 4P: 4pcs) Auxiliary handle: (1pc)

Front connection

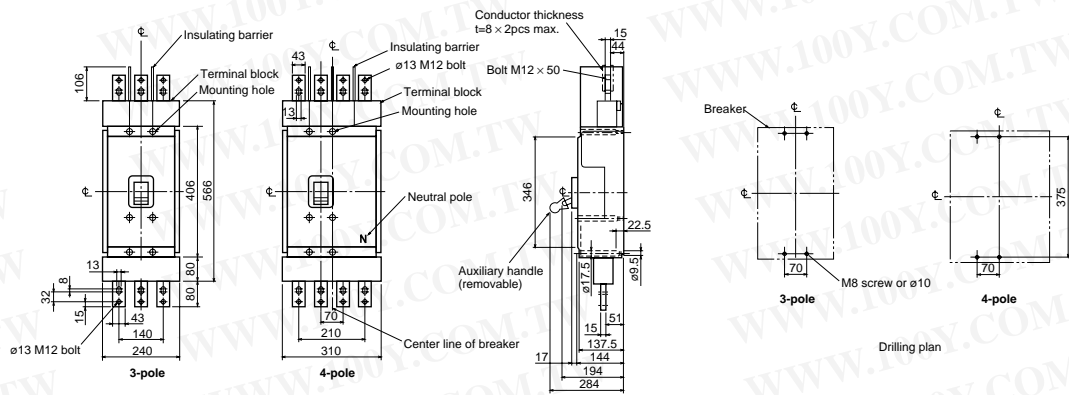

Rear connection

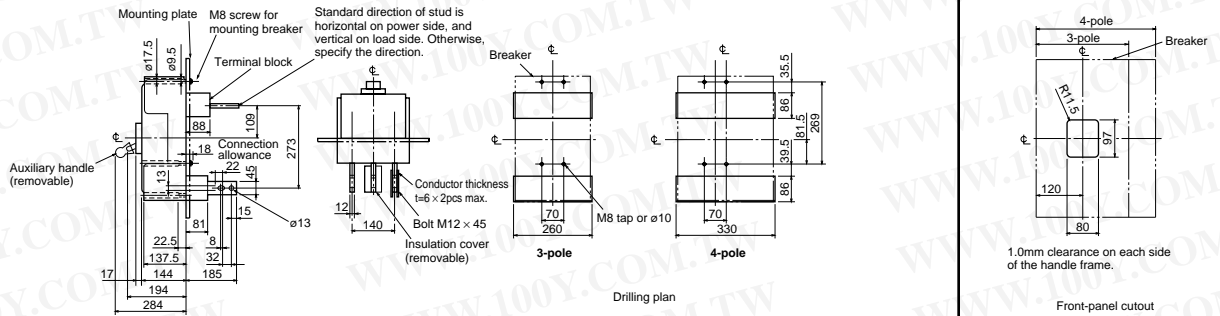

Plug-in

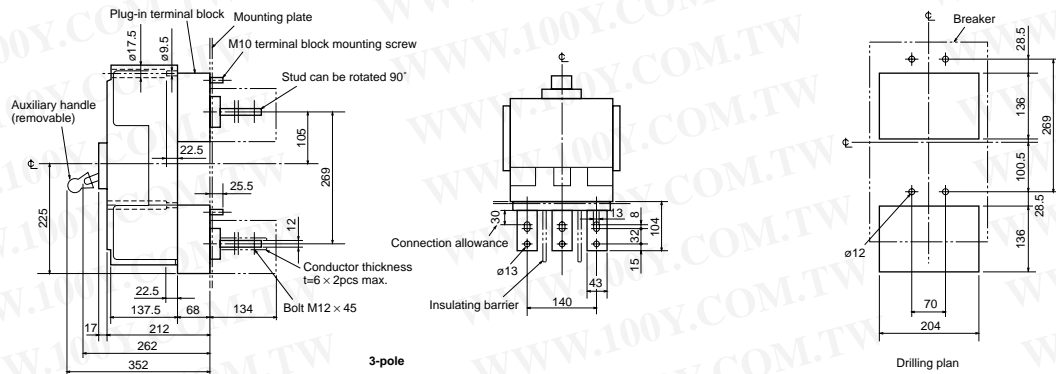

Characteristics and Dimensions

12485

Molded-Case Circuit Breakers

NF1600-SS



Type NF1600-SS

Type name		NF1600-SS		
Rated current In (Amp.)		Adjustable 800, 1000, 1200, 1400, 1500, 1600		
Number of poles		3	4	
Rated insulation voltage Ui (V)		660		
		DC		
Rated short-circuit breaking capacity (kA)	IEC 60947-2 (Icu/lcs)	AC	690V	25/13
			500V	65/33
			440V	85/43
		DC	400V	85/43
			230V	125/63
			250V	—

Operating Characteristics

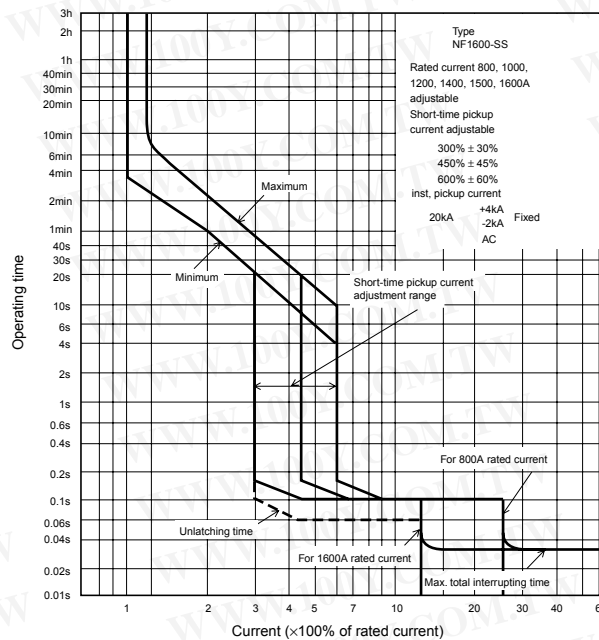

Internal Accessories

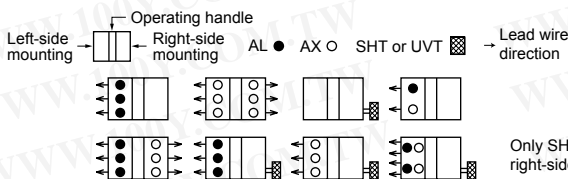

Remark: (1) refer to page 51.

Current reducing curve

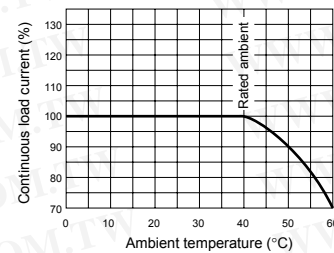

External Accessories

(An order for ☆ should be placed at the same time as an order of circuit breaker main body.)

Accessories	Type name	Reference page	Accessories	Type name	Reference page
Operating handle	F F100 (*1)	61	Auxiliary handle	HT-10SS	76
	S S100	63	Handle lock (HL)	☆	
Mechanical interlock (MI)	MI-16SS3 (*1)	75	Electrical operation device	☆	67

Notes: (*1) The designation depends on the number of poles. Refer to the reference page.

Rated current set available value (A)

NF1600-SS NF1600-PAL	800, 1000, 1200, 1400, 1500, 1600
-------------------------	-----------------------------------

Rated current can be set to 6 steps with screw method.

Standard Attached Parts

Front connection	Mounting screw: M8 × 40 (4pcs) Insulating barrier: (3P: 2pcs, 4P: 3pcs) Auxiliary handle: (1pc)
Rear connection	Mounting screw: M8 × 40 (4pcs) Auxiliary handle: (1pc)

Front connection

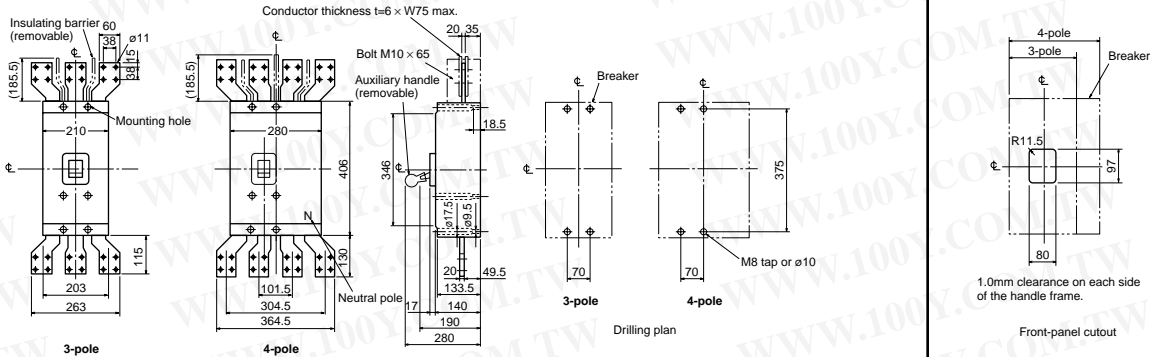

Rear connection

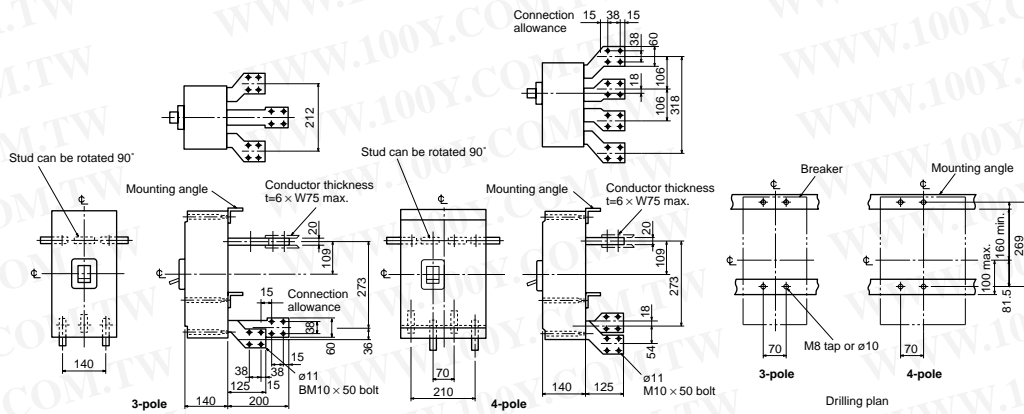

Draw-out

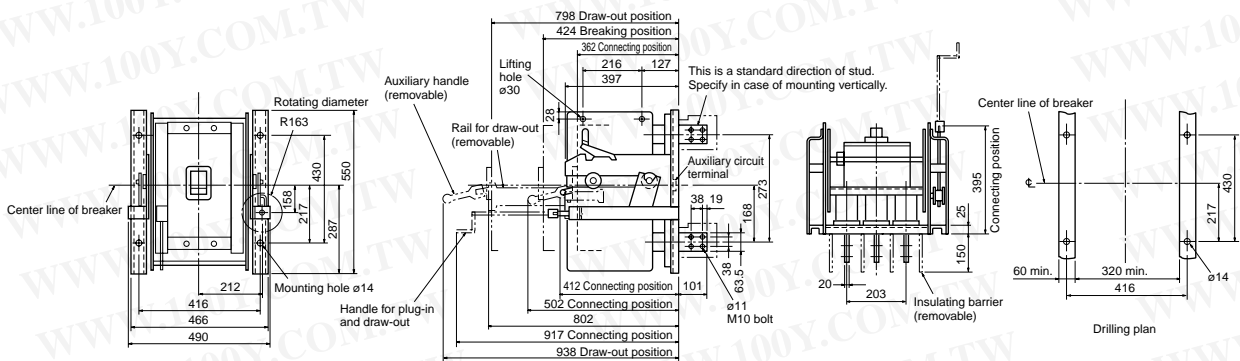

Remarks: (1) Draw-out is only for 3-pole models of NF1600-SS.

Characteristics and Dimensions

12485

Molded-Case Circuit Breakers

NF1600-SSD



Type NF1600-SSD

Type name		NF1600-SSD	
Rated current In (Amp.)		1600	
Number of poles		2	
Rated insulation voltage Ui (V)		DC	
Rated short-circuit breaking capacity (kA)		40/20	
IEC 60947-2 (Icu/Ics)		DC 250V	
Time constant not larger than 10msec			

Operating Characteristics

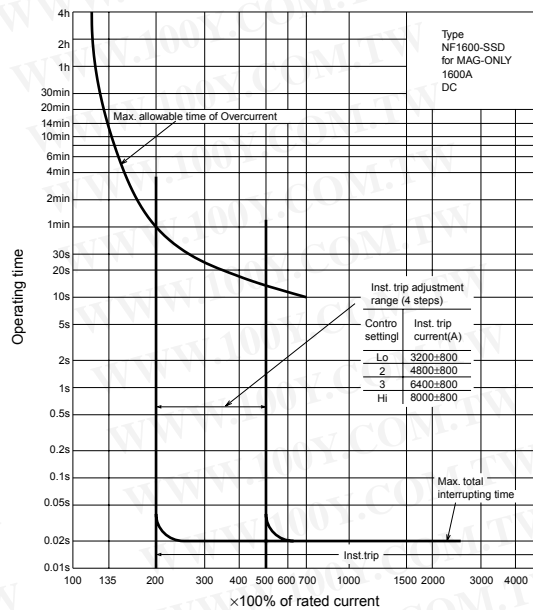

Internal Accessories

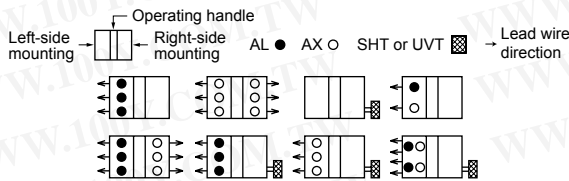

External Accessories

(An order for ☆ should be placed at the same time as an order of circuit breaker main body.)

Accessories	Type name	Reference page	Accessories	Type name	Reference page
Operating handle	F	F100 (*1)	Auxiliary handle	HT-10SS	76
	S	S100	Handle lock (HL)	☆	
Mechanical interlock (MI)	MI-16SS3 (*1)	75	Electrical operation device	☆	67

Note: (*1) The designation depends on the number of poles. Refer to the reference page.

Standard Attached Parts

Front connection	Mounting screw: M8 × 40 (4pcs) Insulating barrier: (2P: 1pc, 3P: 2pcs, 4P: 3pcs) Auxiliary handle: (1pc)
Rear connection	Mounting screw: M8 × 40 (4pcs) Auxiliary handle: (1pc)

Front connection

Outside dimensions are same as those of NF1600-SS.

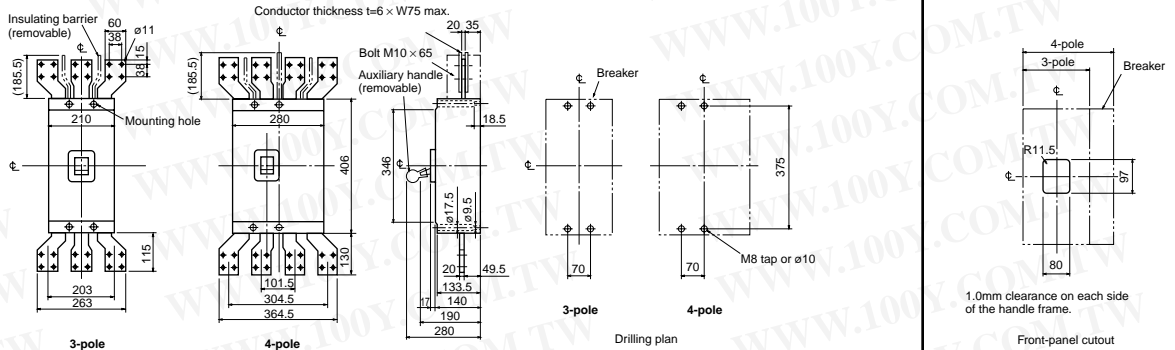

Rear connection

Outside dimensions are different from those of NF1600-SS.

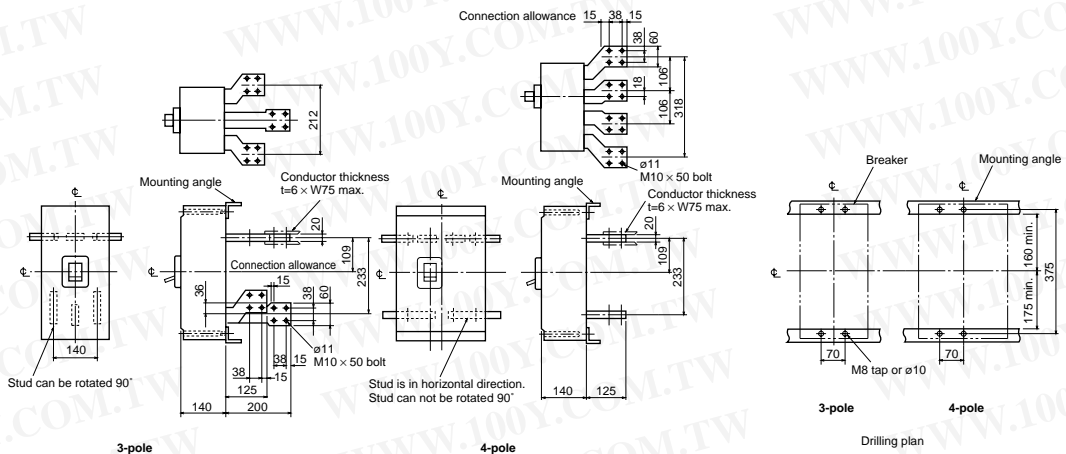

- Remarks: (1) Standard specification of NF1600-SSD is 2-pole model. 3-pole and 4-pole models are for DC special voltage.
 (2) 2-pole models are 3-pole models with the central pole removed.

1. Accessories

Table 5-1: Accessories

Internal accessories	Function	Applicable models	Cassette-type of accessories
AL Alarm switch	A switch that electrically indicates the trip status of the circuit breaker.	NF-C-S-H-U, NV-C-S-H-U and MB series	●
AX Auxiliary switch	A switch that electrically indicates the ON-OFF status of the circuit breaker.		●
SHT Shunt trip	A device that electrically trips the circuit breaker from a remote distance. Permissible working voltages are 70 to 110% of the AC rated voltage or 70 to 125% of the DC rated voltage.	NF-C-S-H-U and MB series	●
UVT Undervoltage trip	A device that automatically trips the circuit breaker if the voltage is lowered. Working voltages are 70 to 35% of the UVT rated voltage. When the voltage recovers to 85% or higher, you can reset the device and put into operation.	NF-C-S-H-U, (Note 1) NV-C-S-H-U and MB series	●
EAL Earth-leakage alarm switch	A switch that electrically indicates the trip status of the earth leakage circuit breaker caused by a ground fault. If 250AF and less, This switch is available only for models with the vertical lead-wire terminal unit (SLT).	NV-C-S-H-U	-
TBM Test button module	This module allows you a remote testing by applying a voltage. An external sequence common to SHT can be used. (The standard configuration requires the vertical lead-wire terminal unit (SLT).)	NV-C-S-H-U	-
MG Insulation switch	The incorporation of this switch enables the measurement of insulation resistance between the terminals of the load with the circuit breaker being turned OFF.	NV-C-S-H-U	-
PAL Pre-alarm module	Indicates that the load current exceeds the pre-alarm setting current.	Electronic Types	-
OAL Overcurrent trip alarm switch	Indicates that the breaker has been tripped by overcurrent or short-circuit current.	Electronic Types (SGW, HGW, RGW, UGW)	-

Note: (1) Models NV250-SEW/HEW are excluded.

Remark: (1) Accessory terminals are marked by both IEC-based terminal symbols and conventional symbols, like 98/ALa.

2. Switch Operation and Rating

Table 5-2: AL Switch Operation

Circuit breaker status	AL switch contact
 OFF or ON	
 Trip	

Table 5-3: AX Switch Operation

Circuit breaker status	AX switch contact
 OFF or Trip	
 ON	

Table 5-4: EAL Switch Operation

Circuit breaker status	EAL switch contact
Over current, short circuit trip or on or off	250A frame or less
	400A frame or more
Ground-fault trip	250A frame or less
	400A frame or more

Table 5-5: MG Switch Operation

Circuit breaker status	MG switch status
 OFF or Trip	
 ON	

Table 5-6: AL-AX-EAL Switch Rating (In case of EAL, 400AF and more)

Switch type	AC			DC		
	Voltage (V)	Current (A)		Voltage (V)	Current (A)	
		Resistive load	Inductive load		Resistive load	Inductive load
S	460	-	-	250	0.2	0.2
	250	3	2	125	0.4	0.4
	125	5	3	30	4	3
V	460	5	2	250	0.3	0.3
	250	10	10	125	0.6	0.6
	125	10	10	30	10	6
X*1	460	5	2.5	250	5	3
	250	10	10	125	10	6
	125	10	10	30	10	10

Note: *1. When DC use polarity must be considered.

Please contact us for applications in the field of smaller current values.

Table 5-7: EAL Switch Rating (250AF and less)

Voltage (V)	AC	
	Current A	
	Resistive load	Inductive load
200	3	2
100	3	2

A control power supply (compatible to 100 and 200V AC) is required; see the diagram on the right showing its wiring. (The permissible range of voltage of the control power supply is 80 to 242V AC, and the power requirement is 10VA.)

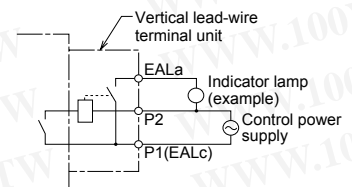

3. Maximum Number of Internally Mounted Accessories

Table 5-8: Combinations of Accessories

Series		NF-C · S · H · U, MB			NV-C · S · H · U	
Type	NF30-CS MB30-CS	NF32-SW NF63-CW/SW/HW NF125-CW/SW	NF32-SW(3P) NF63-CW/SW/HW(3P) NF125-CW(3P), NF125-SW(3P, 4P) NF125-HW, NF125-SGW/HGW NF125-RGW/UGW NF160-SW/SW/HW/HGW NF250-CW/SW/HW NF250-SGW/HGW NF250-RGW/UGW MB30-SW, MB50-CW/SW MB100-SW, MB225-SW	NV30-CS	NV100-SEP NV100-HEP	NV32-SW NV63-CW/SW/HW NV125-CW/SW/HW NV250-CW/SW/HW NV250-SEW/HEW NV125-RW, NV250-RW
Poles	2, 3	2	2, 3, 4	3	3, 4	2, 3, 4
AL						
AX						
AL + AX	 3-pole product only					
SHT or UVT						
AL + SHT or UVT						
AX + SHT or UVT						
AL + AX + SHT or UVT						
MG						
AL + MG						
AX + MG						
EAL						
TBM						
PAL						

Notes: (1) Second AX can substitute the AL on the left-pole.
 (2) Models with UVT require a UVT voltage module to be installed on the lead-wire terminal unit. (No such voltage module is required for SHT.) Part of UVT accessories is not of cassette type. (Details will be available upon request.)
 (3) UVTs for left-pole installation can be produced, if specified, for frame current values of 125A (excluding SGW/HGW/RGW/UGW).
 (4) SHT cannot be installed.
 (5) EALs are available only for models with the vertical lead-wire terminal unit (SLT). Specify a control power supply of either 100 or 200 V AC.
 (6) Models NV250-SEW/HEW are not allowed to install the UVT device.
 (7) The standard lead drawing is performed laterally.
 Load drawing is also available.
 (8) Only the models with an SLT are available. EAL and PAL require a control power supply (shared 100 - 200 VAC).
 For the 24 VDC TBM only, instruct us of a control voltage. (The standard shared voltage is 100 - 240 VAC/100 - 240 VDC.)

Remarks: (1) Circled numbers indicate the order of installation.
 (2) Accessories of EAL, and TBM can be installed independent of installations of AL, AX, and MG. (Two units among EAL, and TBM cannot be installed at the same time.)

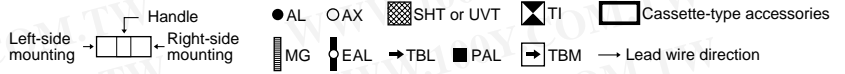

Type	NF-C/S/H	NF400-CP/SP NF400-SEP/HEP/REP	NF630-CP/SP NF630-SEP/HEP/REP NF800-CEP/SDP NF800-SEP/HEP/REP	NF1000-SS NF1250-SS NF1600-SS NF1000-SSD NF1250-SSD NF1600-SSD
	NF-U	NF400-UEP (3P)	NF400-UEP (4P), NF630-UEP, NF800-UEP	NF1250-UR
Poles	2, 3, 4			
Switch type	S		V	
Accessories	AL			
	AX			
	SHT or UVT			
	AL + AX			
	AL + SHT or UVT			
	AX + SHT or UVT			
	AL + AX + SHT or UVT			
	PAL (contact output)			
	TI			

The number within the circle shows the order of mounting.

*1. SHT and UVT are right-pole mounting as standard. Please specify if left-pole mounting is required.

*2. UVT mounting requires a UVT voltage module (SHT requires no such voltage module).

*3. When mounting more than three left-pole mounting devices by SLT, or when mounting a SHT or UVT to the same pole as the AL, AX or AL + AX, a special-order SLT is necessary.

*4. When mounting a UVT to the same pole as the AL, AX, or AL + AX, the UVT voltage module is separate.

*5. SLT-equipped is standard. Control voltage (AC100-200V) is necessary. (In this case, no other accessories can be mounted to the breaker's right pole.)

*6. SLT-equipped is standard. Control voltage (AC100-200V/DC100-200V) is necessary. (In this case, no other accessories can be mounted to the breaker's right pole.)

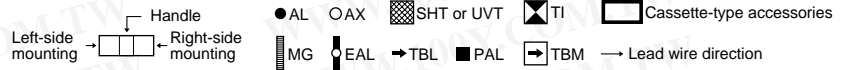

Type	NV-C/S/H	NV400-CP/SP NV400-SEP/HEP/REP	NV630-CP/SP NV630-SEP/HEP NV800-SEP/HEP
Poles		3, 4	
Switch type		S	
Accessories	AL		*2
	AX		*2
	SHT or UVT	*1	*1
	AL + AX	*2	*2
	AL + SHT or UVT	*1 *2 *3	*1 *2 *3
	AX + SHT or UVT	*1 *2 *3	*1 *2 *3
	AL + AX + SHT or UVT	*1 *2 *3	*1 *2 *3
	MG		
	AL + MG		

The number within the circle shows the order of mounting.

*1. UVT mounting requires a UVT voltage module (SHT requires no such voltage module).

*2. When mounting more than three left-pole mounting devices by SLT, or when mounting a SHT or UVT to the same pole as the AL, AX or AL + AX, a special-order SLT is necessary.

*3. When mounting a UVT to the same pole as the AL, AX or AL + AX, the UVT voltage module is separate.

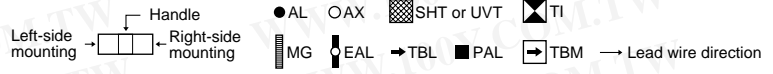

Type	NV-C/S/H	NV400-CP/SP NV400-SEP/HEP/REP	NV630-CP/SP NV630-SEP/HEP NV800-SEP/HEP
Poles		3, 4	
Switch type		S	
Accessories	AX + MG		
	AL + AX + MG		
	EAL		
	TBL		
	TBM		
	PAL (contact output)	 Option for NV400-SEP/HEP/REP	 Option for NV630-SEP/HEP NV800-SEP/HEP
	TI	 Option for NV400-SEP/HEP/REP	 Option for NV630-SEP/HEP NV800-SEP/HEP

The number within the circle shows the order of mounting.

1. EAL, TBL, and TBM can be mounted regardless of the number of AL, AX, SHT, UVT and MG accessories. (However, two EALs, TBLs or TBMs cannot be mounted simultaneously.)

2. The PAL's dimensions and specifications change for the NF-C/S and NV-C/S series.

*1. SLT-equipped is standard. Control voltage (AC100-200V) is necessary. (In this case, no other accessories can be mounted to the breaker's right pole.)

*2. SLT-equipped is standard. Control voltage (AC100-200V/DC100-200V) is necessary. (In this case, no other accessories can be mounted to the breaker's right pole.)



Type	NF-C/S/H	NF50-SWU NF100-CWU NF100-SWU	NF50-SWU NF100-CWU NF100-SWU	NF-SFW NF-SJW NF-HJW	NF225-CWU	NF-SKW	NF-SLW	NV50-SWU NV100-SWU	NV225-CWU	
Poles		2	3				3		3	
Switch type		S					S		S	
Accessories	AL									
	AX									
	SHT or UVT									
	AL + AX									
	AL + SHT or UVT									
	AX + SHT or UVT									
	AL + AX + SHT or UVT									

- Notes: (1) If a UVT is used, a UVT voltage module is installed on the lead wire terminal block. (The SHT requires no voltage module.)
 (2) If a UVT is used, a UVT voltage module is installed on the lead wire terminal block. (The SHT requires no voltage module.) No cassette is attached to the UVT.
 (3) If a UVT is used, the UVT voltage module is externally installed. (The SHT requires no voltage module.)
 (4) No SHT can be installed.
 (5) The 2nd AX can be installed instead of the AL on the left pole.
 (6) The standard mounting of the SHT and the UVT is performed on the right pole. If mounting on the left pole is required, instruct us. (The UVTs for interlocks are mounted on the left pole.)
 (7) We can manufacture the SLTs used when 3 or more accessories are installed on the left pole and the SLTs used when the AL and the AX are attached on the same pole that is attached with the SHT or the UVT at your order.
 (8) If a UVT is used and an AL, an AX or an AL + an AX are attached to the same pole that is attached with the UVT, the UVT voltage module is separately installed.

Remarks: (1) Encircled numbers show the order of mounting.

4. Shunt Trip (SHT)

Table 5-9: Standard Coil Rating

Series	Cut-off switch	Voltage (V)	Input power requirement (VA) (Note 1)		Operating time (ms) (Note 2)
			AC	DC	
NF-C • S • H • U MB NV-C • S • H • U	Equipped	AC100-240 380-550 (Compatible to 50 and 60Hz.) DC100-125	120	50	15 or less
				60	
		AC100~450/DC100~200 (50 also 60Hz)	100V : 20 200V : 50 330V : 120 450V : 170	100V : 10 200V : 35	5~15
				70	
AC100-120 200-240 380-450 (50 also 60Hz) DC100	200	70			

Notes: (1) Secure a sufficient input power so that the voltage will not drop below the permissible lower working voltage (70% of the lowest rated voltage).
(2) The operating time denotes the time from when the rated voltage is applied to SHT until when the main contact of the breaker starts to open.

Table 5-10: Coil Ratings (List of manufacturable special voltages)

MCCB type	AC (V)				DC (V)									AC/DC (V)
	24	24~48	48	380~550	12	24	24~36	36	36~48	48	110	125	220~250	24~48
NF-C • S • H • U MB 32(30) • 63A Frame 125A Frame 160 • 250A Frame	-	●	-	-	●	-	●	-	●	-	-	-	●	-
NF400-CP/SP/SEP/HEP/REP, NF630-CP/SP/SEP/HEP/REP, NF800-SDP/CEP/SEP/HEP/REP, NF400-UEP, NF630-UEP, NF800-UEP NV400-CP/SP/SEP/HEP/REP, NV630-CP/SP/SEP/HEP, NV800-SEP/HEP	-	-	-	●	●	-	-	-	-	-	-	-	-	●
NF1000-SS/SSD, NF1250-SS/SSD/UR NF1600-SS/SSD	●	-	●	-	●	●	-	●	-	●	●	●	-	-

5. Undervoltage Trip (UVT)

Table 5-11: Coil Rating

Series	Voltage (V) (Note 1)		Input power (VA)	Operating time (ms) (Note 2) (Note 3)
	Standard voltage	Special voltage (note 5)		
250AF and less	AC100-110/120-130 selectable 200-220/230-250 selectable 380-415/440-480 selectable (Note4) DC100/110 selectable	AC24/48 selectable 500-550/600 selectable DC24/48 selectable 110/125 selectable	5	30 or less
NF400-CP/SP/SEP/HEP/REP/UEP, NF630-CP/SP/SEP/HEP/REP/UEP, NF800-CEP/SDP/SEP/HEP/REP/UEP, NF400-CP/SP/SEP/HEP/REP, NF630-CP/SP/SEP/HEP, NF800-SEP/HEP	AC100-110 200-220 400-440 (Note4) DC100	AC110-120 220-240 380-415 440-480 500-550 (Note4) DC24 48 110	5	5~30
NF1000-SS/SSD, NF1250-SS/SSD/UR, NF1600-SS/SSD	AC100-120 200-240 380-450 (Note4) DC100-110	AC24 DC24 48 48 440-480 120-125 500-550 (Note4)	5	5~35

Notes: (1) A desired voltage can be selected by changing the terminal wiring.
(2) The operating time denotes the time from when no voltage is applied to UVT until when the main contact of the breaker starts to open.
(3) Time-delayed types can be produced. Details will be available upon request.
(4) Compatible to 50 and 60Hz
(5) Rated voltage differs according to make and country of manufacture. Please consult your dealer.

UVT Voltage Module

The UVT voltage module is normally installed on the vertical lead-wire terminal unit (SLT). (A separate-mount type can be produced upon request.)

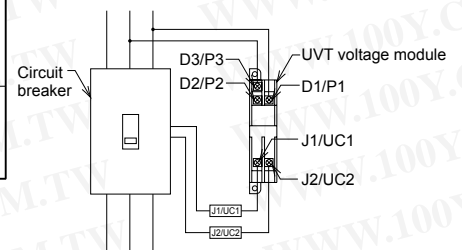

UVT Voltage Module Wiring Diagram (Lead-Wire Connection)

6. Test Button Module (TBM)

- The effect of pressing the test button on the breaker main body is produced while the input control voltage is applied. (Apply the voltage for more than two seconds for the breaker main body of time-delayed NV models.)
- The model with the vertical lead-wire terminal unit (SLT) is standard.

Table 5-12

Series	NV-C • S • H • U
Input rated control voltage (V)	Compatible to AC100-240/DC100-240 (DC24) (Note 1)
Input control power (VA)	1VA or less

Note: (1) The specifications of 100-240V AC/100-240V DC are standard unless otherwise specified. The specifications of 24 V DC are available if requested.

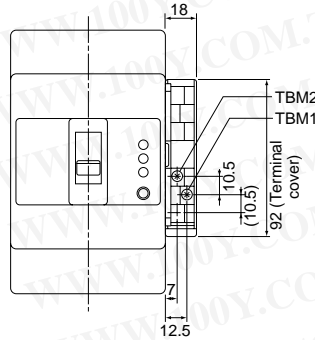

7. Lead-wire Specifications

Table 5-13

Type	Size	Length	Marking	Ring-mark example						
Heat-resistant wire	0.5mm ²	(Note 1) 450mm	A ring-mark marked by the terminal symbol is attached to each lead-wire.	<table border="1"> <tr> <td>98/ALa</td> <td>96/ALb</td> <td>95/ALc</td> </tr> <tr> <td>C1/S1</td> <td>C2/S2</td> <td></td> </tr> </table>	98/ALa	96/ALb	95/ALc	C1/S1	C2/S2	
98/ALa	96/ALb	95/ALc								
C1/S1	C2/S2									

Note: (1) The length is 400 mm for the model of four-pole, right-pole installation.

- Lead wires are normally extended laterally.
- Grooves are provided standardly on the side face of the breaker, allowing the extension of the lead wires along them. (Note 1)

Note: (1) The models of NF125-SGW/HGW/RGW/UGW, NF160-SGW/HGW, NF250-SGW/HGW/RGW/UGW, 400Aframe and more are excluded.

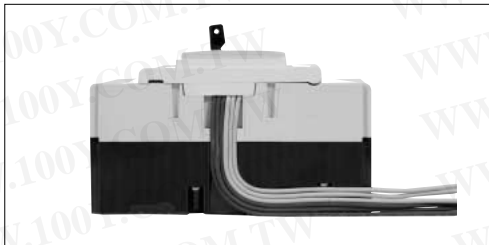

8. Internal Terminal Type (INT)

- This unit is an internal accessory that is provided with terminal screws for lead-wire connection.

Remark: (1) Available for the models of NF125-SGW/HGW/RGW/UGW, NF160-SGW/HGW, NF250-SGW/HGW/RGW/UGW.

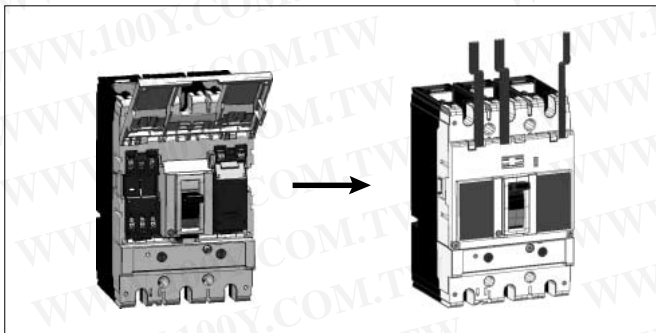

Internal Accessories

9. Vertical Lead-wire Terminal Block (SLT)

- The circuit breaker can be mounted, being closely fitted to the unit.
- Terminal screws are arranged in a zigzag pattern, and screws can be tightened further after wiring.
- A terminal cover is provided standardly.
- This unit supports the models of front connection, rear connection, and plug-in type (excluding PLT).

■NFB

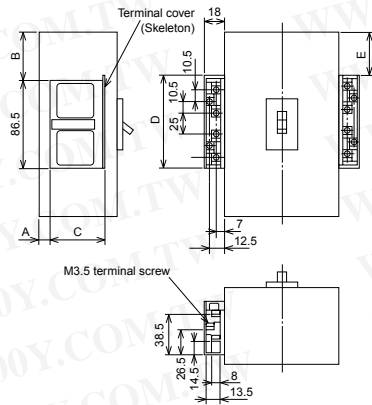

Table 5-14: Summary of Dimensions

Applicable models	A	B	C	D	E
NF30-CS, MB30-CS	4	4.5	44.5	86.5	4.5
NF32-SW, NF63-CW/SW/HW					
MB30-SW, MB50-CW/SW	7	17.5	54	86.5	17.5
NF50-SWU	7	27.5	54	86.5	27.5
NF125-CW/SW/HW	7	19	54	86.5	19
NF100-CWU, NF100-SWU	7	29	54	86.5	29
NF125-HGW, NF225-HGW	25	25	54	86.5	25
NF-SFW,NF-SJW, NF-HJW	25	35	54	86.5	35
NF250-CW/SW/HW, NF225-CWU, NF160-SW/HW	7	37	54	86.5	37
NF400-CP/SP/SEP/HEP/REP, NF-SKW	41	79.5	54	86.5	79.5
NF630-CP/SP/SEP/HEP/REP, NF800-CEP/SDP/SEP/HEP/REP, NF-SLW		88.5	54	86.5	88.5
NF1000-SS/SSD, NF1250-SS/SSD, NF1600-SS/SS (Note1)	62.5	173	52	86.5	173
NF400-UEP(3P)		119.5	54	86.5	119.5
NF400-UEP(4P), NF630-UEP, NF800-UEP	138	135.5	54	86.5	135.5

Note: (1) SLT can not be mounted when more than 3 pieces of accessories are mounted on one side in larger frame than 1000A frame.
Remark: (1) Terminal screw tightening torque M3.5 ... 0.9~1.2N·m

■NV

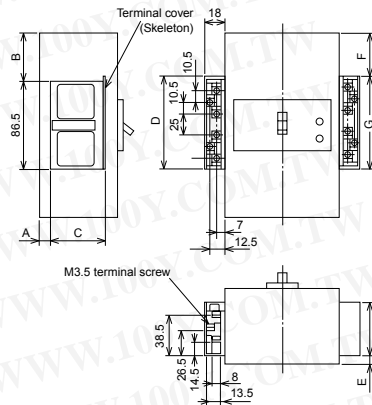

Table 5-15: Summary of Dimensions

Applicable models	A	B	C	D	E	F	G
NV30-CS	4	4.5	44.5	86.5	4	4.5	86.5
NV32-SW, NV63-CW/SW/HW	7	17.5	54	86.5	7	21.5	92
NV50-SWU	7	27.5	54	86.5	7	31.5	92
NV125-CW/SW/HW	7	19	54	86.5	7	19	86.5
NV100-SWU	7	29	54	86.5	7	29	86.5
NV100-SEP/HEP	7	30	54	86.5	2.5	30	92
NV250-CW/SW/HW, NV250-SEW/HEW, NV225-CWU	7	37	54	86.5	2.5	37	92
NV125-RW	7	80	54	86.5	7	80	86.5
NV250-RW	7	112	54	86.5	2.5	112	92
NV400-CP/SP/HP/HEP/REP	41	79.5	54	86.5	26.5	79.5	92
NV630-CP/SP/SEP/HEP, NV800-SEP/HEP	41	88.5	54	86.5	26.5	88.5	92

Remarks: (1) Terminal screw tightening torque M3.5 ... 0.9~1.2N·m
(2) Lead-wire terminal block for TBL is attached to right-side.

■14 Terminals SLT

SLT when three and more than three pieces of internal accessories are mounted on left-side.

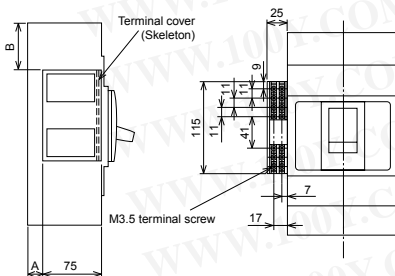

Table 5-16

Applicable models		A	B
NFB	NV		
NF400-CP/SP/SEP	NV400-CP/SP/SEP	20	60
NF400-HEP/REP, NF-SKW	NV400-HEP/REP		
NF400-UEP(3P)	-	117	100
NF630-CP/SP/SEP	NV630-CP/SP/SEP/HEP NV800-SEP/HEP	20	69
NF630-HEP/REP			
NF800-CEP/SDP/SEP NF800-HEP/REP, NF-SLW			
NF400-UEP(4P), NF630-UEP, NF800-UEP	-	117	116

Remark: (1) Terminal screw tightening torque

10. Pre-Alarm Module (PAL)

This module functions to give alarm output when load current exceeds a preset current level and serves for securing continuous power supply and also for preventive maintenance. The electronic breakers with mount digital ETR of 125 to 800AF

are provided with this module as an option. (Some modules are with this module as standard equipment.) 1000 to 2000AF are prepared for exclusive use.

Table 5-17

Type	Pre-alarm LED (Auto reset)	Solid state relay (SSR) output-Contactless output (Auto reset)		Pre-alarm module-Contact output (1a)		
		Switching capacity	Switching capacity	(Self-holding)	Switching capacity	Reset system
NF125-SGW/HGW	Standard equipment	Option	24VDC 100-200VAC 20mA	Option	100VAC or 200VAC 2A	Press the reset switch or turn off control power.
NF160-SGW/HGW						
NF250-SGW/HGW						
NV100-SEP/HEP		—				
NV250-SEW/HEW						
NF400-SEP NF400-HEP NF400-REP						
NF400-UEP NF630-SEP NF630-CEP						
NF630-REP NF630-UEP NF800-CEP						
NF800-SEP NF800-HEP NF800-REP						
NF800-UEP		Option	24VDC 100-200VAC 20mA			
NV400-SEP NV400-HEP NV400-REP						
NV630-SEP NV630-HEP NV800-SEP						
NV800-HEP						

- ①Pre-alarm LED The LED starts blinking on the circuit breaker when load current exceeds the preset current, then changes to continuous glowing when pre-alarm output is given.
- ②Solid-state relay output Open the upper cover of the circuit breaker, connect the connector of the lead wire packed together and use it as the lead wire outlet. In this case, only the lead wire outlet of the internal accessories can be attached to the right pole. (For flush plate type, the outlet is manufactured in advanced as a PAL mount.)
- ③Pre-alarm module SLT is attached as standard and is used as the control power source of 100VAC or 200VAC. In this case, no other internal accessories can be attached to the right pole. (Auto resetting is also applicable.)

●Pre-alarm characteristics

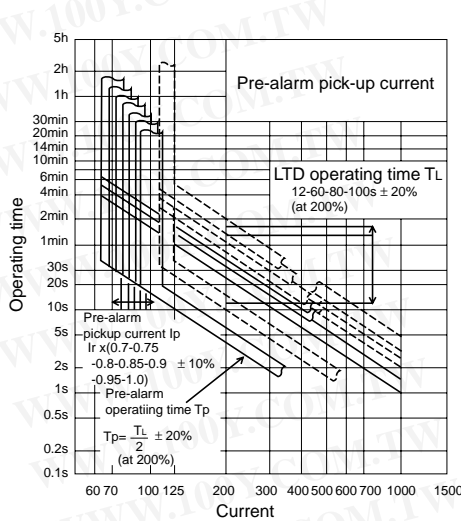

Percentage (%) to rated current or preset current rating (NF/NV125,250AF)

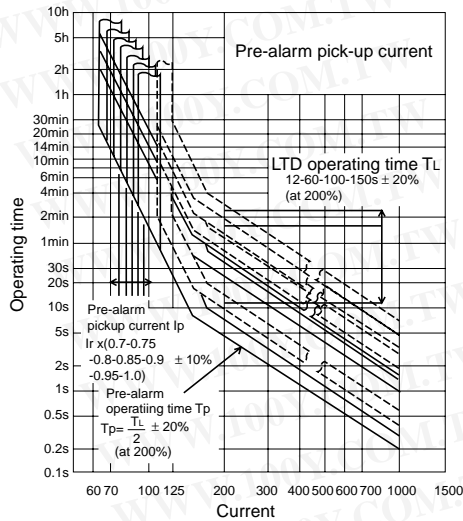

Percentage (%) to rated current or preset current rating (NF/NV400,630,800AF)

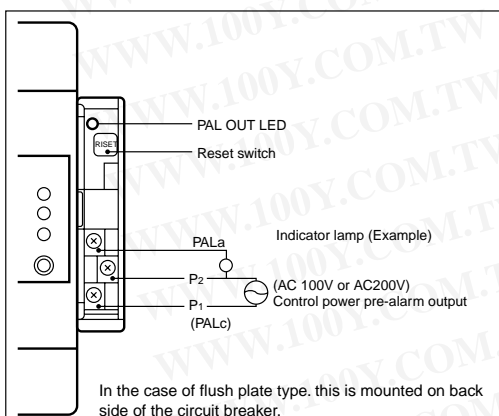

11. Trip Indicator (TI)

When the breaker is tripped, this accessory installed on the right side will display the cause of the trip--either long delay (LTD) , short or instantaneous (STD/INST), earth-leakage (EAL) (with earth-leakage breakers only)--on its LED and output an alarm signal. In this case, both LTD and STD/INST are treated as overcurrent trips (OAL) and output signals. Pre-alarm is also output. Again, with this module, it is impossible to connect other internal accessories to the breaker's right side.)

Table 5-18

Type	LED contents
NF400-SEP/HEP/REP/UEP NF630-SEP/HEP/REP/UEP NF800-CEP/SEP/HEP/REP/UEP	Long-time delay, Short-time delay, Instantaneous, Pre-alarm
NV400-SEP/HEP/REP, NV630-SEP/HEP, NV800-SEP/HEP	Long-time delay, Short-time delay, Instantaneous, Earth-leakage, Pre-alarm

* Requires 100-200VAC control voltage.

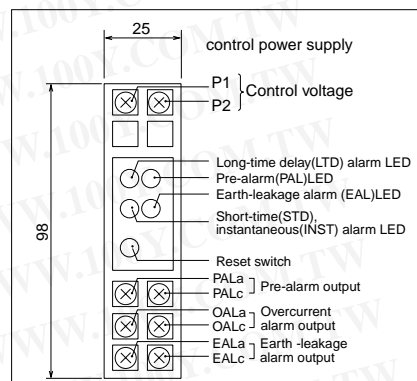

12. 3ø4W Neutral-pole protection Relay (NR)

- In a 3-phase 4-wire circuits, the voltage rise of the circuit by phase failure of a neutral line is detected, and a contact output is taken out.

Table 5-19

Phase/wire type		3 ø 4W				
Rated voltage	VAC	415				
Usable supply voltage	VAC	304-484				
Tripping characteristics	Usable voltage (line voltage)	VAC	380	400	415	440
	Total operating overvoltage (phase voltage) (135% of total phase voltage)	VAC	296	312	323	343
	Total non-operating overvoltage (phase voltage) (120% of total phase voltage)	VAC	263	277	288	305
	Total overvoltage operating time	(s)	1			
	Overvoltage non-operating time	(s)	More than 0.1			
Trip indication method	Button					
Reset method	Reset button (open-phase display use)					
External output contacts	1c					
	Voltage	AC		DC		
		cos ø		Voltage	L/R	
	1.0	0.4	0		0.007	
	100, 120V	7A	7A	30V	7A	6A
200, 240V	7A	7A	125V	0.6A	0.6A	
415V	5A	2A	250V	0.3A	0.3A	

Remark: Using with a shunt-trip device (SHT) equipped breaker will improve tripping and phase protection.

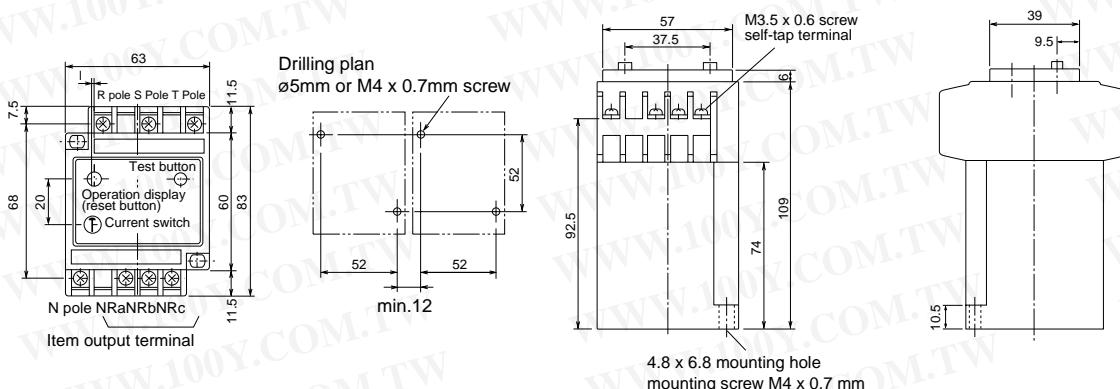

1. V-type Operating Handle

- Appearance (Color N1.5)



- This handle in conjunction with the breaker main enables the isolation function effective.
- The safety standards of EN Standards (EN60204-1) are satisfied.
- Degrees of protection (IEC60529) IP65 is satisfied standardly.
- OFF-position lock only is available for up to three commercial padlocks (ø8).
- A door-lock mechanism allows the door to be opened at OFF-position only.

● Outside Dimension Diagram

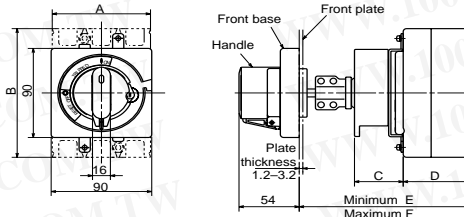

Center of Hinge and Circuit Breaker

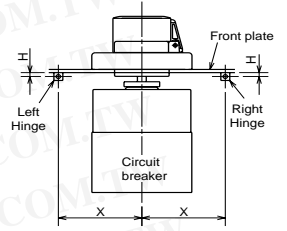

● Mounting-hole Drilling Dimension Diagram

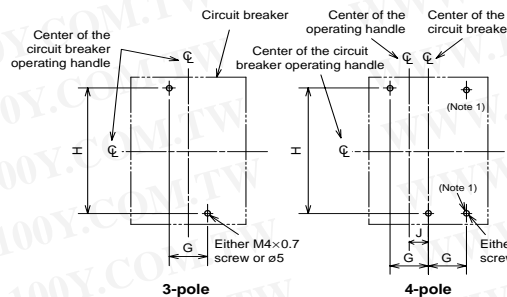

H	X
0 or more	(5H+100) or more

The above illustration shows a view of the hinges and the circuit breaker when viewed from the direction of the load.

● Front Plate Drilling Dimension Diagram

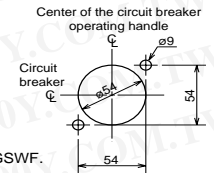

Table 5-20: Summary of Dimensions

Type name	Applicable models	Number of poles	Dimensions (mm)									
			A	B	C	D	E	F	G	H	J	
V05SW	NF32-SW, NF63-CW/SW/HW, NV32-SW NV63-CW/SW/HW, MB30-SW	3P	75	130	44	61	154	300	25	111	-	
		4P	100								12.5	
V05SWF (Note 2)	MB50-CW/SW	3P	75	-	-	-	-	-	-	-	-	
		4P	100	-	-	-	-	-	-	-	-	
V1SW	NF125-CW/SW/HW, NV125-CW/SW/HW MB100-SW	3P	90	130	44	61	154	518	30	111	-	
		4P	120								15	
V1SWF (Note 2)	MB100-SW	3P	90	-	-	-	-	-	-	-	-	
		4P	120	-	-	-	-	-	-	-	-	
V2SW	NF160-SW/HW, NF250-CW/SW/HW, NV250-CW/SW/HW NV250-SEW/HEW, MB225-SW	2P, 3P	105	165	46	61	154	518	35	126	-	
		4P	140								17.5	
V2SWF (Note 2)	MB225-SW	2P, 3P	105	-	-	-	-	-	-	-	-	
		4P	140	-	-	-	-	-	-	-	-	
V2GSW	NF125-SGW/HGW, NF160-SGW/HGW, NF250-SGW/HGW	2P, 3P	105	165	46	79	172	536	35	126	-	
		4P	140								17.5	
V2GSWF (Note 2)	NF125-SGW/HGW, NF160-SGW/HGW, NF250-SGW/HGW	2P, 3P	105	-	-	-	-	-	-	-	-	
		4P	140	-	-	-	-	-	-	-	-	

Notes: (1) This hole is not required for two and three poles.
(2) The last letter of "F" of the type designations of V-type operating handles denotes a fixed type.

Remark: (1) You may contact us for details of the V-type operating handle for the U series.

*Equipped with cylinder key (option) to prevent deliberate operation.

- Can be locked in OFF position only.
- The door is locked when ON and can only be opened in OFF position.
- Degrees of protection (in accordance with IEC60529): IP65.

External dimensions

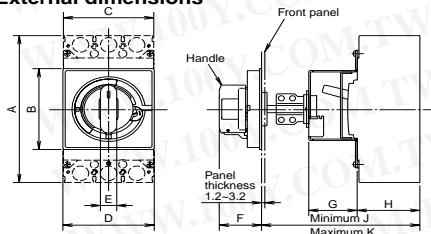

Outview

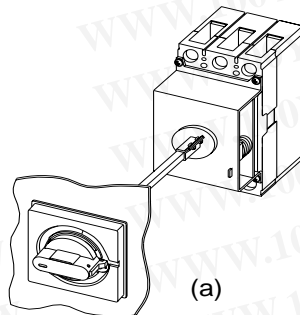

Drilling plan

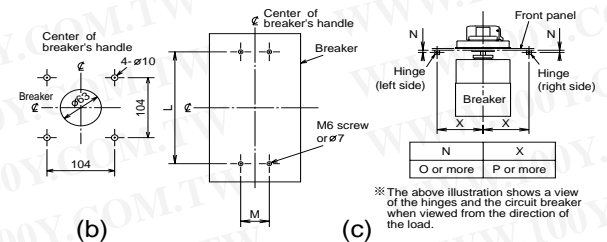

Table 5-21

Type	Breakers type		Fig.	Drilling plan	Dimensions (mm)												
	MCCB	ELCB			A	B	C	D	E	F	G	H	J	K	L	M	P
V4SPW	NF400-CP, NF400-SP, NF400-SEP, NF400-HEP	-	a	b, c	257	140	140	140	25	62	76	97	217	539	194	44	8N+150
V4SPWNV	-	NV400-CP, NV400-SP, NV400-SEP, NV400-HEP			275	140	210	140	25	62	76	97	217	539	243	70	8N+150
V6SPW	NF630-CP, NF630-SP, NF630-SEP, NF630-HEP, NF800-CEP, NF800-SDP, NF800-SEP, NF800-HEP	-			257	140	140	140	25	62	76	97	191	-	194	44	8N+150
V4SPWF	NF400-CP, NF400-SP, NF400-SEP, NF400-HEP	-			275	140	210	140	25	62	76	97	191	-	243	70	8N+150
V4SPWFNV	-	NV400-CP, NV400-SP, NV400-SEP, NV400-HEP			257	140	140	140	25	62	76	97	191	-	194	44	8N+150
V6SPWF	NF630-CP, NF630-SP, NF630-SEP, NF630-HEP, NF800-CEP, NF800-SDP, NF800-SEP, NF800-HEP	-			275	140	210	140	25	62	76	97	191	-	243	70	8N+150

External Accessories

2. F-type Operating Handle

● Appearance (Color N1.5)



- This handle in conjunction with the breaker enables the isolation function effective.
- The standard model is equipped with a safety device that prevents the circuit breaker from being turned on if the door is open. (If not desired, please specify so.)
- The handle can be locked at either ON or OFF position. (Three padlocks (40mm) can be installed. OFF-position lock only specifications are also acceptable.)
- Degrees of protection (IEC60529) IP3X (IP5X with dustproof packing)

Remark: (1) Trip action can be displayed when the circuit breaker trips even if ON-position lock is selected (only in the case of a single padlock (35 mm)).

● Outside Dimension Diagram

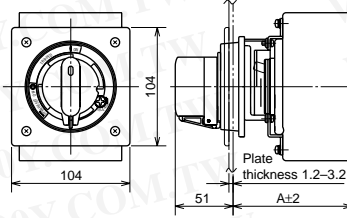

● Drilling Dimension Diagram

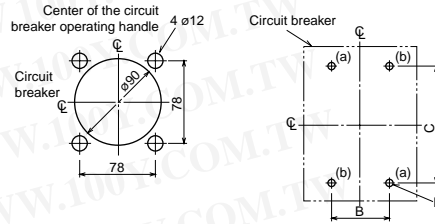

Center of Hinge and Circuit Breaker

Left hinge		Right hinge	
H	X ₁	H	X ₂
0 or more	(5H+100) or more	Less than 10	170 or more
		10 or more	(5H+120) or more

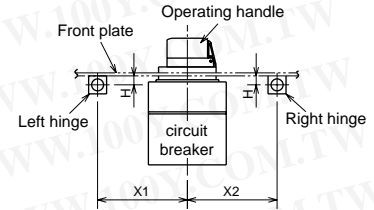

The above illustration shows a view of the hinges and the circuit breaker when viewed from the direction of the load.

Table 5-22: Summary of Dimensions

Type name	Applicable models	Number of poles	Dimensions (mm)				Mounting screws
			A*1	B	C	D	
*2 F05SW2P	*3 F05SWR2P	NF32-SW, NF63-CW/SW/HW	105	—	111	Either M4×0.7 screw or ø5	(a) Circuit breaker mounting screws (2pcs) (b) Handle mounting screws (2pcs)
*2 F05SW	*3 F05SWR	NF32-SW, NF63-CW/SW/HW, NV32-SW, NV63-SW/HW, MB30-SW, MB50-CW/SW, NV63-CW/SW		25			
*2 F1SW2P	*3 F1SWR2P	NF125-CW/SW/HW		—	111		
*2 F1SW	*3 F1SWR	NF125-CW/SW/HW, NV125-CW/SW/HW, MB100-SW	30				
*2 F2SW	*3 F2SWR	NF160-SW/HW, NF250-CW/SW/HW, NV250-CW/SW/HW, NV250-SEW/HEW, MB225-SW	107	35	126		
*2 F2GSW	*3 F2GSWR	NF125-SGW/HGW, NF160-SGW/HGW, NF250-SGW/HGW	125	35	126		

*1. Dimensions of both front connection and rear connection are shown. The plug-in type has a different reference plane for mounting the circuit breaker.

*2. The standard type is equipped with a door-lock mechanism that allows door to be opened only when OFF operation is carried out.

*3. In case of reset opened type use.

Remarks: (1) The test button becomes difficult to press when an operating handle is installed on an NV model. Then, use models with either TBM instead.

(2) Dustproof packings are separately available.

(3) You may consult us for details of the F-type operating handle for the U series.

● Appearance (Color N1.5)

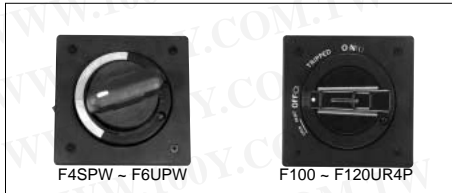

- Includes as standard a safety device which prevents breaker closing as long as the cover is open. (Specify if this safety feature is not required.)
- Indicates the tripping of the breaker even in ON-lock position—but only in cases when a single padlock (35mm) is used.
- Degrees of protection (in accordance with IEC60529): IP3X (IP5X with provision of dustproof packing).

● External dimensions

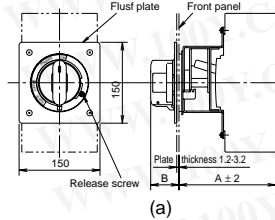

● Drilling plan

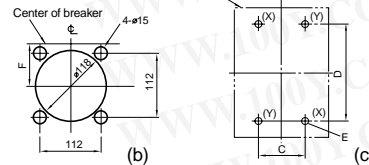

Center of Hinge and Circuit Breaker

Left hinge		Right hinge	
H	X ₁	H	X ₂
0 or more	(8H+150) or more	0 or more	(4H+120) or more

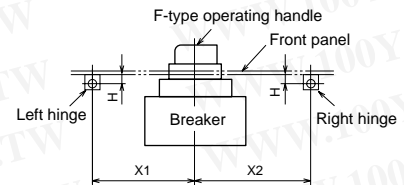

The figure above shows the relationship between the hinge and breaker viewed from the load side of the breaker.

Table 5-23

Type	Breaker type	Number of poles	Fig		Dimensions (mm)						Mounting crews				
			External dimensions	Drilling plan	*5 A	B	C	D	E	F					
*6 F4SPW	*7 F4SPWR	NF400-CP/SP/SEP/HEP/REP	a	b	c	183	44	194	M6 screw or ø7	—	20				
*6 F4SPWNV	*7 F4SPWRNV	NV400-CP/SP/SEP/HEP/REP										280	44	234	
*6 F4UPW	*7 F4UPWR	NF400-UEP				183	70	243		—	23.5				
*6 F6SPW	*7 F6SPWR	NF630-CP/SP/SEP/HEP/REP, NF800-CEP/SDP/SEP/HEP/REP										280	70	290	
*6 F6SPWNV	*7 F6SPWRNV	NV630-CP/SP/SEP/HEP, NV800-SEP/HEP				221	50	70	375	M8 screw or ø10	—				
*6 F6UPW	*7 F6UPWR	NF400-UEP (4P), NF630-UEP, NF800-UEP										280	70	290	
*7 F100	NF1000-SS/SSD, NF1250-SS/SSD	2P, 3P										225	70	375	—
*7 F1004P	NF1600-SS/SSD	4P													
*7 F120UR	NF1250-UR	3P													
*7 F120UR4P		4P													

*1. Handles with NV in the product name include a test button.

*2. Dustproof packing is also available as an option.

*3. Other optional handles can also be mounted.

*4. F4SPW-F6UPW are for isolation purposes.

(Specify OFF lock only.)

*5. The figures show the dimensions of the front connection. Some connection and plug-in breakers have a different reference surface for mounting purposes.

*6. The standard type is equipped with a door-lock mechanism that allows the door to be opened only when OFF operation is carried out.

*7. In case of reset opened type use.

Specification explanation for F-type operating handles

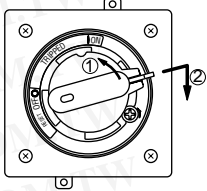
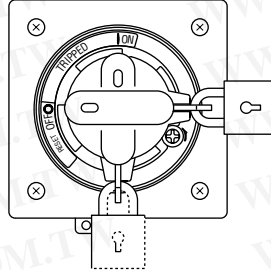
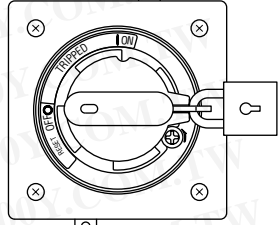
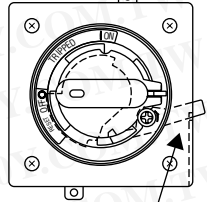
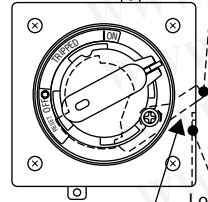
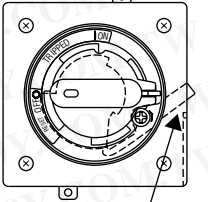
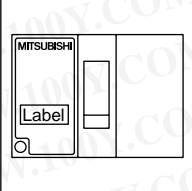
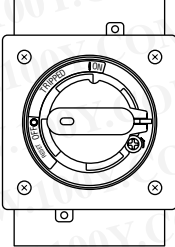
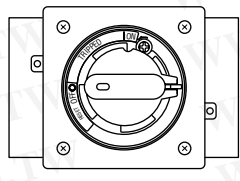
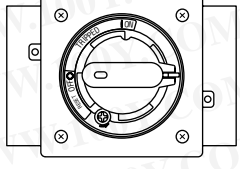
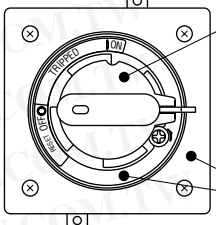
Specification	Detailed explanation	Kind		
<p>Handle lock position</p> 	<p>The position where it can lock with the padlock. Can not open, when it use padlock.</p> <p>When OFF-lock, please turn handle in RESET direction.</p>	<p>ON and OFF-position lock</p> 	<p>OFF-position lock only</p> 	
<p>Door opening system</p>	<p>The door can be opened with the operating handle RESET-position or OFF-position. When the operating handle was locked, the panel (door) can not be opened.</p>	<p>RESET-position open</p> <p>OFF-position</p>  <p>Lock lever locked by lock plate</p> <p>RESET-position</p>  <p>Lock lever unlocked by lock plate</p> <p>Lock lever</p> <p>Lock plate</p>		<p>OFF-position open</p> <p>OFF-position</p>  <p>Lock lever unlocked by lock plate</p>
<p>Mounting direction</p> <p>The top of label is ON side of breaker</p> <p>ON side</p> 	<p>Reconstruction to vertically from horizontally can not be performed.</p>	<p>Vertically type (ON side of breaker is upper)</p> 	<p>Horizontally type (ON side of breaker is left)</p> 	<p>Horizontally type (ON side of breaker is right)</p> 
<p>For emergency</p> <p>*You may consult us for details of emergency</p>	<p>For emergency stop use.</p> <p>(In accordance with EN60204-1)</p>	 <p>Red color</p> <p>Yellow color</p>		

3. S-type Operating Handle

● Appearance (Color N1.5)



- The handle can be locked at either ON or OFF position. (Three padlocks (40mm) can be installed. Off-position lock only specifications are also acceptable.)
- Degrees of protection (IEC60529) IP5X

Remark: (1) Trip action can be displayed when the circuit breaker trips even if ON-position lock is selected (only in the case of a single padlock (35 mm)).

● Outside Dimension Diagram

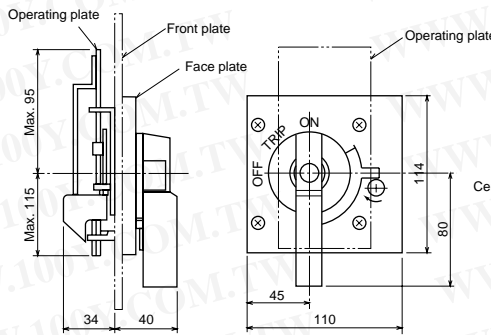

● Front Plate Drilling Dimension Diagram

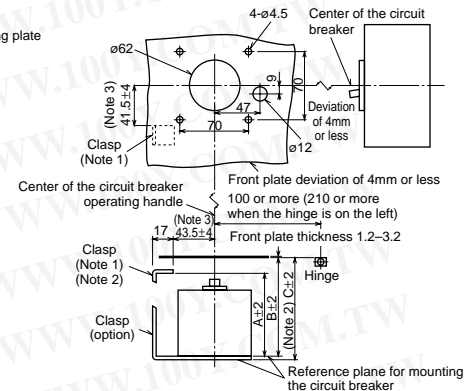

Table 5-24: Summary of Dimensions

Type name	Applicable models	Dimensions (mm)		
		A (Note 4)	B (Note 4)	C (Note 4)
S05SW	NF32-SW, NF63-CW/SW/HW, NV32-SW, NV63-CW/SW/HW, MB30-SW, MB50-CW/SW	87	102	104.5
S1SW	NF125-CW/SW/HW, NV125-CW/SW/HW, MB100-SW, NV125-RW (Note 5)			
S2SW	NF160-SW/HW, NF250-CW/SW/HW, NV250-CW/SW/HW, NV250-SEW/HEW, MB225-SW, NV250-RW (Note 5)	95	110	112.5
S2GSW	NF125-SGW/HGW, NF160-SGW/HGW, NF250-SGW/HGW	113	128	130.5

Notes: (1) The clasps are not supplied standardly, and should be prepared by users. Details on dimensions and others will be available upon request.
 (2) When the optional clasp is used.
 (3) The tolerance from the center of ø62 is shown.
 (4) The dimensions of the front-face type are shown. Some of the back-face and plug-in types have a different reference plane for mounting the circuit breaker.
 (5) The front plate drilling dimensions for the U series differ from those shown above. Please consult us for their details.

Remark: (1) Reset open-type
 (2) These are not suitable for isolation.

● Appearance (Color N1.5)

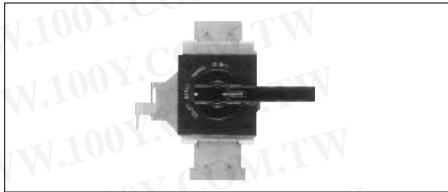

- Indicates the tripping of the breaker even in ON-lock position--but only in cases when a single padlock (35mm) is used.
- Degrees of protection (in accordance with IEC60529): IP5X.

● External dimensions

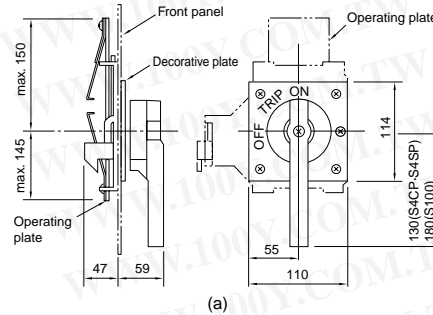

● Drilling plan

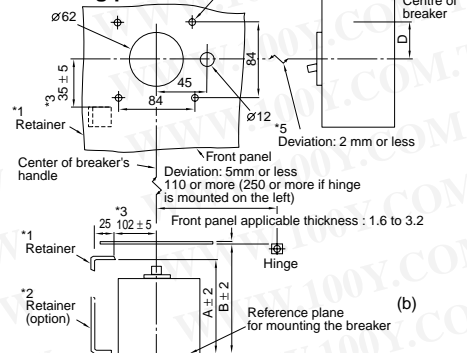

Table 5-25

Type	Breaker type	Fig		Dimensions (mm)			
		External dimensions	Drilling plan	A*4	B*4	C*4	D
S4CP *5	NF400-CP, NV400-CP	a	b	140	156	—	0
S4SP *5	NF400-SP/SEP/HEP/REP, NF630-CP/SP/SEP/HEP/REP, NV630-CP/SP/SEP/HEP, NF800-CEP/SDP/SEP/HEP/REP, NV800-SEP/HEP	a	b	162	178	—	—
	NF400-UEP (3P)			259	275	—	20
	NF400-UEP (4P), NF630-UEP, NF800-UEP			259	275	—	23.5
S100	NF1000-SS/SSD, NF1250-SS/SSD	a	b	199	215	—	0
	NF1600-SS/SSD, NF1250-UR			203	219	—	0

Notes: *1. Retainers are not included. They must be provided by the customer.

Remark: (1) Reset open-type

*2. When using optional retainer.

*3. Shows the tolerance for the distance from the center of a 62mm dia. hole.

*4. The figures show the front-connection dimensions. Some rear-connection and plug-in breakers have a different reference surface for mounting purposes.

*5. S4CP and S4SP are for isolation purposes. (Specify OFF lock only.) The tolerance is less than 5mm. It does not conform to isolation purposes, however, if the deviation is more than 2mm.

● Surface plate interlocking fastening (separately available)

Operation handle series	Type	Breaker type		Dimensions (mm)		Drilling diagram and referential diagram
		MCCB	ELCB	A	B	
S-type	TG-S05SW	NF32-SW, NF63-CW/SW/HW, MB30-SW, MB50-CW/SW, NF125-CW/SW/HW, MB100-SW	NV32-SW, NV63-CW/SW/HW, NV125-CW/SW/HW	67	119	
	TG-S1UW	NF125-RGW/UGW	NV125-RW			
	TG-S05SP	—	NV100-SEP, HEP			
	TG-S2SW	NF160-SW/HW, NF250-CW/SW/HW, NF250-SEW/HEW, MB225-SW	NV250-CW/SW/HW, NV250-SEW/HEW			
	TG-S2UW	NF250-RGW/UGW	NV250-RW			
	TG-S2GSW	NF125-SGW/HGW, NF160-SGW/HGW, NF250-SGW/HGW, NF-SFW, NF-SJW, NF-HJW	—			
	TG-S4CP	NF400-CP	NV400-CP			
	TG-S4SP	NF400-SP/SEP/HEP/REP, NF630-CP/SP/SEP/HEP/REP, NF800-CEP/SDP/SEP/HEP/REP, NF-SKW, NF-SLW	NV400-SP/SEP/HEP/REP, NV630-CP/SP/SEP/HEP, NV800-SEP/HEP			
	TG-S4UP	NF400-UEP (3P)	—			
	TG-S100	NF1000-SS/SSD, NF1250-SS/SSD	—			
TG-S120UR	NF1250-UR	—				

Remark: The clamp for surface plate interlock fastener is common to 2P, 3P and 4P.

4. R-type Operating Handle

● Appearance (Color N1.5)



● Outside Dimension Diagram

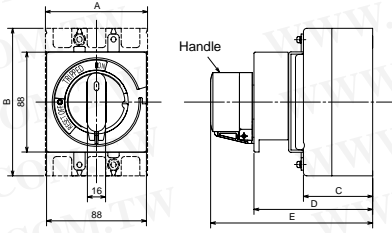

● Mounting-hole Drilling Dimension Diagram

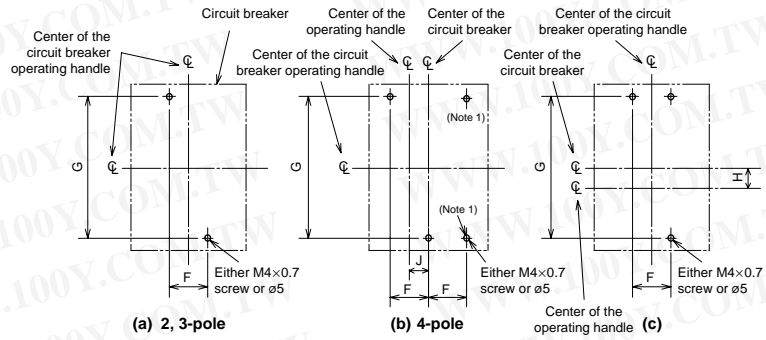

Note 1: The drilling at this position is not required for the models of R2GSW.

Table 5-26: Summary of Dimensions

Type name	Applicable models	Number of poles	Fig Drilling plan	Dimensions (mm)								
				A	B	C	D	E	F	G	H	J
R1SW	NF125-CW, NF125-SW, NF125-HW NV125-CW, NV125-SW, NF125-HW	3P	a	90	130	61	105	142	30	111	—	—
		4P	b	120								15
R1UW	NV125-RW	3P	c	90	191	61	105	142	30	172	30.5	—
R2SW	NF160-SW, NF160-HW, NF250-CW, NF250-SW, NF250-HW NV250-CW, NV250-SW, NF250-HW, NV250-SEW NV250-HEW	2P, 3P	a	105	165	61	107	144	35	126	—	—
		4P	b	140								17.5
R2UW	NV250-RW	3P	c	105	240	61	107	144	35	201	37.5	—
R2GSW	NF125-SGW, NF125-HGW, NF160-SGW, NF160-HGW, NF250-SGW, NF250-HGW	2P, 3P	a	105	165	79	125	162	35	126	—	—
		4P	b	140								17.5
R2GUW	NF125-RGW, NF125-UGW, NF250-RGW, NF250-UGW	3P	c	105	240	79	125	162	35	201	37.5	—

* Equipped with cylinder key (option) to prevent deliberate operation.

● Can be locked in OFF position only.

Outview

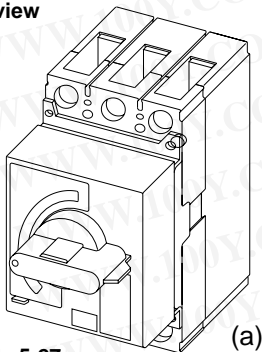

External dimensions

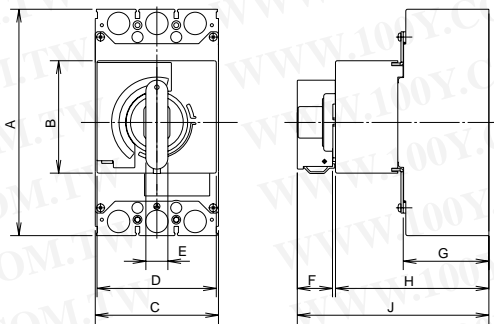

Drilling plan

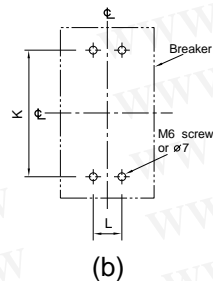

Table 5-27

Type	Breaker type		Fig Outview	Drilling plan	Dimensions (mm)											
	MCCB	ELCB			A	B	C	D	E	F	G	H	J	K	L	M
R4SPW	NF400-CP, NF400-SP, NF400-SEP, NF400-HEP	—	a	b	257	128	140	140	25	43	97	174	218	194	44	—
R4SPWNV	—	NV400-CP, NV400-SP, NV400-SEP, NV400-HEP														—
R6SPW	NF630-CP, NF630-SP, NF630-SEP, NF630-HEP NF800-CEP, NF800-SDP, NF800-SEP, NF800-HEP	NV630-CP, NV630-SP, NV630-SEP, NV630-HEP, NV800-SEP, NV800-HEP														—

Ordering information

V	1	SW	E	F	NV
1)	2)	3)	4)	5)	6)
1) V : Operating handle type	V..... Variable-depth handle				
	R..... Rotary handle				
2) 1 : Frame size of breaker	05..... NF32-SW, NF63-CW/SW/HW, MB30-SW, MB50-CW/SW, DSN32-SW, DSN63-CW/SW, NV32-SW, NV63-CW/SW/HW				
	1..... NF125-CW/SW/HW, NV125-CW/SW/HW, MB100-SW, DSN125-CW/SW, NV125-RW				
	2..... NF160-SW/HW, NF250-CW/SW/HW, MB225-SW, NV250-CW/SW/HW/SEW/HEW, DSN250-CW/SW, NV250-RW				
	2G..... NF125-SGW/HGW, NF160-SGW/HGW, NF250-SGW/HGW, DSN125-SGW, DSN160-SGW, DSN250-SGW, NF125-RGW/UGW, NF250-RGW/UGW				
	4..... NF400-CP/SP/SEP/HEP/REP, DSN400-CP/SP, NV400-CP/SP/SEP/HEP/REP				
	6..... NF630-CP/SP/SEP/HEP/REP, DSN630-CP/SP, DSN800-CP/SP, NF800-CEP/SDP/SEP/HEP/REP, NV630-CP/SP/SEP/HEP, NV800-SEP/HEP				
3) SW : Series name	SW indicate WSS C, S and H series				
	SPW indicate PSS C, S and H series				
	UW indicate WSS U series				
4) E : For emergency	Blank..... For general				
	E..... For emergency				
5) F : Adjustment type of depth (For only V-handle)	Blank..... Variable type				
	F..... Fix type				
6) NV : Type of breaker	NV..... NV type for 400A frame				
	Blank..... The other				

S	1	SW	A
1)	2)	3)	4)
1) S : Operating handle type			
2) 1 : Frame size of breaker	05..... NF32-SW, NF63-CW/SW/HW, MB30-SW, MB50-CW/SW, DSN32-SW, DSN63-CW/SW, NV32-SW, NV63-CW/SW/HW		
	1..... NF125-CW/SW/HW, NV125-CW/SW/HW, MB100-SW, DSN125-CW/SW, NV125-RW		
	2..... NF160-SW/HW, NF250-CW/SW/HW, MB225-SW, NV250-CW/SW/HW/SEW/HEW, DSN250-CW/SW, NV250-RW		
	2G..... NF125-SGW/HGW, NF160-SGW/HGW, NF250-SGW/HGW, DSN125-SGW, DSN160-SGW, DSN250-SGW		
	4..... NF400-CP/SP/SEP/HEP/REP, DSN400-CP/SP, NV400-CP/SP/SEP/HEP/REP, NF400-UEP, NF630-CP/SP/SEP/HEP/REP, DSN630-CP/SP, DSN800-CP/SP, NF800-CEP/SDP/SEP/HEP/REP, NV630-CP/SP/SEP/HEP, NV800-SEP/HEP, NF400-UEP(4P), NF630-UEP, NF800-UEP		
3) SW : Series name	SW indicate WSS C, S and H series		
	CP indicate PSS C series		
	SP indicate PSS S, H and U series		
4) A : Handle lock position	Blank..... ON/OFF position lock		
	A..... OFF position lock only		

S	100
1)	2)
1) S : Operating handle type	
2) 100 : Frame size of breaker	100..... NF1000-SS/SSD, NF1250-SS/SSD, NF1600-SS/SSD, NF1250-UR

F	1	SW	A	R	Y	2P	NV
1)	2)	3)	4)	5)	6)	7)	8)
1) F : Operating handle type							
2) 1 : Frame size of breaker	05..... NF32-SW, NF63-CW/SW/HW, MB30-SW, MB50-CW/SW, DSN32-SW, DSN63-CW/SW, NV32-SW, NV63-CW/SW/HW						
	1..... NF125-CW/SW/HW, NV125-CW/SW/HW, MB100-SW, DSN125-CW/SW, NV125-RW						
	2..... NF160-SW/HW, NF250-CW/SW/HW, MB225-SW, NV250-CW/SW/HW/SEW/HEW, DSN250-CW/SW, NV250-RW						
	2G..... NF125-SGW/HGW, NF160-SGW/HGW, NF250-SGW/HGW, DSN125-SGW, DSN160-SGW, DSN250-SGW, NF125-RGW/UGW, NF250-RGW/UGW						
	4..... NF400-CP/SP/SEP/HEP/REP, DSN400-CP/SP, NV400-CP/SP/SEP/HEP/REP, NF400-UEP						
	6..... NF630-CP/SP/SEP/HEP/REP, DSN630-CP/SP, DSN800-CP/SP, NF800-CEP/SDP/SEP/HEP/REP, NV630-CP/SP/SEP/HEP, NV800-SEP/HEP, NF400-UEP(4P), NF630-UEP, NF800-UEP						
3) SW : Series name	SW indicate WSS C, S and H series						
	SPW indicate PSS C, S and H series						
	UW indicate WSS U series						
	UPW indicate PSS U series						
4) A : Handle lock position	Blank..... ON/OFF position lock						
	A..... OFF position lock only						
5) R : Door open position	Blank..... OFF position open						
	R..... RESET position open						
6) Y : Mounting direction	Blank..... Vertically type (ON side of breaker is upper)						
	Y..... Horizontally type (ON side of breaker is left)						
	Z..... Horizontally type (ON side of breaker is right)						
7) 2P : Number of poles	Blank..... 3 pole and 4 pole						
	2P..... 2 pole						
8) NV : Type of breaker	NV..... NV type for 400 to 800 A frame						
	Blank..... The other						

F	100	4P
1)	2)	3)
1) F : Operating handle type		
2) 100 : Frame size of breaker	100..... NF1000-SS/SSD, NF1250-SS/SSD, NF1600-SS/SSD	
	120UR..... NF1250-UR	
3) 4P : Number of poles	Blank..... 2 pole and 3 pole	
	4P..... 4 pole	

5. Terminal Cover

Table 5-28

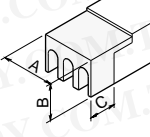
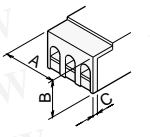
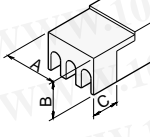
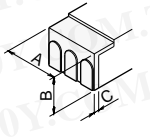
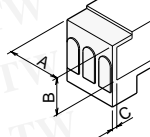
Breaker type		Large terminal cover (TC-L)	Small terminal cover (TC-S)	Transparent terminal cover (TTC)	Rear terminal cover (BTC)	Plug-in terminal cover (PTC)
						
NF30-CS, MB30-CS	2P	TCL-03CS2W (43.5×30.5×25)	TCS-03CS2W (43.5×30.5×5)	TTC-03CS2 (43.5×30.5×25)	BTC-03CS2W (43.5×30.5×6.5)	—
NF30-CS, NV30-CS, MB30-CS	3P	TCL-03CS3W (67×30.5×25)	TCS-03CS3W (67×30.5×5)	TTC-03CS3 (67×30.5×25)	BTC-03CS3W (67×30.5×6.5)	—
NF32-SW, NF63-CW/SW/HW	2P	(Note 1) TCL-05SW2W (50×65.5×25)	(Note 1) TCS-05SW2W (50×65.5×5)	(Note 1) TTC-05SW2 (50×65.5×25)	BTC-05SW2W (50×65.5×6.5)	PTC-05SW2W (50×65.5×6.5)
NF32-SW, NF63-CW/SW/HW NV32-SW, NV63-CW/SW/HW, MB30-SW MB50-CW/SW	3P	(Note 2) TCL-05SW3W (75×65.5×25)	(Note 2) TCS-05SW3W (75×65.5×5)	(Note 2) TTC-05SW3 (75×65.5×25)	BTC-05SW3W (75×65.5×6.5)	PTC-05SW3W (75×65.5×6.5)
NF125-CW/SW/HW	2P	(Note 1) TCL-1SW2W (60×65.5×40)	(Note 1) TCS-1SW2W (60×65.5×6.5)	(Note 1) TTC-1SW2 (60×65.5×40)	BTC-1SW2W (60×65.5×6.5)	PTC-1SW2W (60×65.5×6.5)
NF125-CW/SW/HW, NV125-CW/SW/HW, NF125-RW, MB100-SW	3P	(Note 2) TCL-1SW3W (90×65.5×40)	(Note 2) TCS-1SW3W (90×65.5×6.5)	(Note 2) TTC-1SW3 (90×65.5×40)	BTC-1SW3W (90×65.5×6.5)	PTC-1SW3W (90×65.5×6.5)
NF160-SW/HW, NF250-CW/SW/HW, NV250-CW/SW/HW, NV250-SEW/HEW, NV250-RW MB225-SW	2P 3P	(Note 2) TCL-2SW3W (105×65.5×40)	(Note 2) TCS-2SW3W (105×65.5×6.5)	(Note 2) TTC-2SW3 (105×65.5×40)	BTC-2SW3W (105×65.5×6.5)	PTC-2SW3W (105×65.5×6.5)
NF125-SGW/HGW/RGW/UGW, NF160-SGW/HGW NF250-SGW/HGW/RGW/UGW	2P 3P	IP40 TCL-2GSW3W (105×84×40)	TCS-2GSW3W (105×84×6.5)	TTC-2GSW3 (105×84×40)	BTC-2GSW3W (105×84×6.5)	PTC-2GSW3W (105×84×6.5)

Notes: (1) Attach the letter "F" to the end of model designation for models with F-type operating handle. (Those are F-type operating-handle dedicated models, and screws are used for fixing.)

(2) An F-type operating handle can be installed standardly.

Remarks: (1) Parenthesized numbers denote the outside dimensions (A×B×C in mm).

(2) The terminal cover for a four-pole model can be produced upon request.

Table 5-29

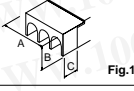
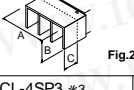
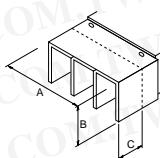
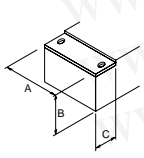
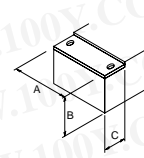
Breaker type		Large terminal cover (TC-L)	Transparent terminal cover (TTC)	Rear terminal cover (BTC)	Plug-in terminal cover (PTC)
		 Fig.1  Fig.2			
NF400-CP/SP/SEP/HEP/REP NV400-CP/SP/SEP/HEP/REP	2P, 3P	TCL-4SP3 #3 TCL-4SP3W #4 (171X99.5X110)	TTC-4SP3 (171X104.5X110)	BTC-4SP3 BTC-4SP3W #4 (140X99.5X42)	PTC-4SP3 (140X99.5X42)
NF400-UEP	3P	TCL-4SP3 #1 TCL-4SP3W #4 (171X132.5/196.5X110)	—	BTC-4SP3 #1 BTC-4SP3W #4 (140X132.5/196.5X42)	—
NF400-SP/SEP/HEP, NV400-SEP/HEP	4P	TCL-4SP4 #4 (240X104.5X110)	TTC-4SP4 (240X104.5X110)	BTC-4SP4 #2 (185X97.5X39)	—
NF630-CP/SP/SEP/HEP/REP, NV630-CP/SP/SEP/HEP NF800-CEP/SDP/SEP/HEP/REP, NV800-SEP/HEP	2P, 3P	TCL-6SP3 #5 (224X103.5X155)	TTC-6SP3 (224X103.5X155)	BTC-6SP3 #2 (210X97.5X32)	—
NF630-UEP, NF800-UEP	3P	TCL-6UP3 #1 (220X146/194.5X155)	—	BTC-6SP3 #1,#2 (210X146/194.5X32)	—
NF630-SP/SEP/HEP, NV630-SEP NF800-SEP/HEP	4P	TCL-6SP4 #6 (294X103.5X155)	TTC-6SP4 (294X103.5X155)	BTC-6SP4 #2 (280X97.5X32)	—
NF400-UEP, NF630-UEP, NF800-UEP	4P	TCL-6UP4 #1 (290X146/194.5X155)	—	BTC-6SP4 #1,#2 (280X146/194.5X32)	—
NF1000-SS/SSD NF1250-SS/SSD	2P, 3P	TCL-10SS3 (220X139X150)	—	—	—
NF1000-SS/SSD NF1250-SS/SSD	4P	TCL-10SS4 (290X139X150)	—	—	—
NF1250-UR	3P	TCL-12UR3 (250X143X230)	—	—	—
NF1250-UR	4P	TCL-12UR4 (320X143X230)	—	—	—

Remarks: 1. () Shows external dimensions in mm. (AXBXC)

* 1. Line side/Load side

* 2. These covers can be mounted on plug-in type.

* 3. Except for NF400-HEP/REP and NV400-HEP/REP.

* 4. Color is white.

6. Electrical Operation Device

● 250A Frame and less

Table 5-30: Summary of Model Designations

Applicable models		(Note 1)	NF125-CW(3P) NF125-SW(3P, 4P) NF125-HW	NF160-SW/HW NF250-CW/SW/HW MB225-SW	NF125-SGW/HGW NF160-SGW/HGW NF250-SGW/HGW	NV125-CW/SW/HW	NV250-CW/SW/HW	NV250-SEW/HEW
Rated operating voltage	24V DC		MDSD024-NF1SWE	MDSD024-NF2SWE	MDSD024-NF2GSWE	MDSD024-NV1SWE	MDSD024-NV2SWE	MDSD024-NVE2SWE
	48-60V DC		MDSD060-NF1SWE	MDSD060-NF2SWE	MDSD060-NF2GSWE	MDSD060-NV1SWE	MDSD060-NV2SWE	MDSD060-NVE2SWE
	Compatible to 100-240V AC/100-250V DC		MDSAD240-NF1SWE	MDSAD240-NF2SWE	MDSAD240-NF2GSWE	MDSAD240-NV1SWE	MDSAD240-NV2SWE	MDSAD240-NVE2SWE

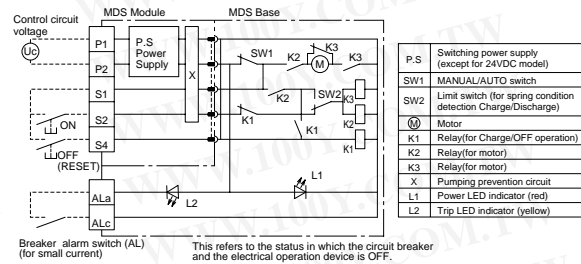

Table 5-31: Specifications

Rated operating voltage (Allowable voltage range 85~110%)		24V DC	48-60VDC	Compatible to 100-240V AC/100-250V DC
Operating time (s)	ON action		0.05~0.1	
	OFF action		0.6 or less	
	Charging action		1.2 or less	
Power requirement (VA)			150	

Note: (1) Place an order of other models in conjunction with the circuit breaker.
Remarks: (1) The standard terminal cover can be used.
(2) Please contact us for details of the outside dimensions.

MDSD024 -NF2SWE MDSD024 -NV2SWE/NVE2SWE
MDSD060 -NF2SWE MDSD060 -NV2SWE/NVE2SWE
MDSAD240-NF2SWE MDSAD240-NV2SWE/NVE2SWE



others

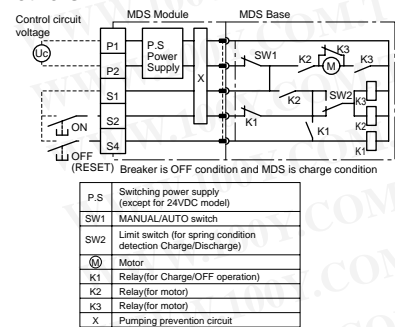

● 400A Frame and more

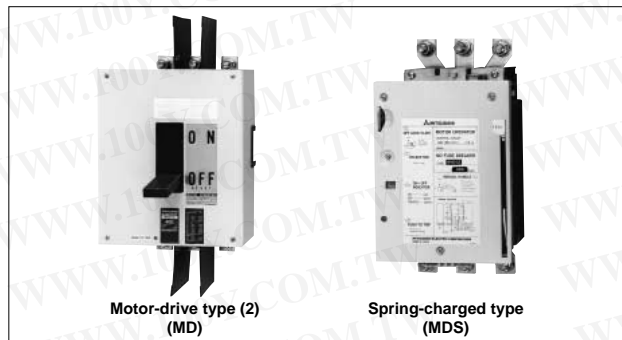

Table 5-32

MCCB type	NF-C series	NF400-CP NF630-CP NF800-CEP	—	NF400-CP NF630-CP NF800-CEP	—			
		NF-S-H series	NF400-SP NF400-SEP/HEP/REP NF630-SP NF630-SEP/HEP/REP NF800-SEP/HEP/REP	NF1000-SS NF1000-SSD NF1250-SS NF1250-SSD NF1600-SS NF1600-SSD	NF400-SP NF400-SEP/HEP/REP NF630-SP NF630-SEP/HEP/REP NF800-SEP/HEP/REP	NF1000-SS NF1000-SSD NF1250-SS NF1250-SSD NF1600-SS NF1600-SSD		
	NF-U, MB series	NF400-UEP NF630-UEP NF800-UEP	NF1250-UR	NF400-UEP NF630-UEP NF800-UEP	NF1250-UR			
ELCB type	NV-C series	NV400-CP NV630-CP	—	NV400-CP NV630-CP	—			
	NV-S-H series	NV400-SP NV400-SEP/HEP/REP NV630-SEP/HEP/REP NV800-SEP/HEP/REP	—	NV400-SP NV400-SEP/HEP/REP NV630-SEP/HEP/REP NV800-SEP/HEP/REP	—			
	MN series	—	—	—	—			
Electrical operation system		Motor-drive type (2)	Motor-drive type (2)	Spring-charged type	Spring-charged type			
Rated operating voltage (V) (Allowable voltage range 85~110%)*1		100/110VDC, 100/110VAC, 200/220VAC (125VDC, 240VAC)						
Operating current (A, rms)*2	DC	100/110V	3.0 (8.0)	4.0 (8.0)	1.0 (3.0)	8	1.0 (3.0)	9
	AC	100/110V	4.0 (8.0)	5.0 (10.0)	1.0 (3.0)	10	1.0 (3.0)	10
		200/220V	2.0 (4.5)	3.5 (7.0)	0.5 (1.5)	8	0.5 (1.5)	8
Operating time (s)	On	Less than 0.3 (self-holding)		0.05		0.07		
	Off	Less than 0.3 (self-holding)		Less than 3 (self-holding)		Less than 3 (self-holding)		
Required transformer capacity (VA)		400	700	700	700	700	700	
Endurance voltage (V)		1500						

*1. () voltages are special options and might require an external resistor. For details, consult your dealer.
*2. () shows starting currents.

General precautions for motor-operated electrical MCCBs

- Motor-operated types have intermittent ratings, and therefore they should not be operated more than 10 times consecutively (one on/off counts as an operation).
- The operating voltage should be between 85~110% of the rated control voltage.
- When the breaker is tripped by trip button or breakdown (i.e., overload or short circuit), the breaker will not show that it has been tripped (except for motor-operated type 1 breakers).
- The dielectric strength of the electrical operating circuits is 1500V. When performing a dielectric strength test simultaneously with another device at a voltage over 1500V, the operating circuit terminal should be disconnected.

Automatic Reset

- If the breaker is an auto reset type, it contains a built-in alarm switch and the off-control circuit closes when the breaker is tripped. Since the breaker automatically resets itself after tripping, the power is easily restored by switching on the breaker again. With a UVT mounted, however, auto reset may not be possible. In this case, please consult your dealer.

Electrically Operated MCCBs and ELCBs

Motor-operated type (2)

- Electrical operation
Forward and reverse motor rotation is changed by ball screw to switch the breaker ON and OFF (reset).
- Manual operation
The manual operation handle can be used to switch the breaker ON and OFF directly.
- Cautions during electrical operation
 1. In case the UVT operates and a circuit breaker trips if the breaker has a UVT, the re-closing procedure may differ according to the state of the breaker before tripping.
When the circuit breaker trips while turned ON..... Reset (OFF) -> Turn ON
When the circuit breaker trips while turned OFF..... Turn ON (idle tripping) -> Reset (OFF) -> Turn ON
(If it fails to turn ON (idle tripping), please operate Reset (OFF) and turn ON.)
 2. Do not send ON and OFF signals consecutively. An interval of at least 0.5s is required between each ON and OFF.
 3. For models with auto reset capability, resetting after an NFB trip should be performed after an interval of 0.5s.

4. The electrical operating device is equipped with a pumping prevention circuit. Although it is possible to set the device to OFF while it is set to ON, it is impossible to return it to ON immediately. To return to ON, first shut off the ON switch, then set it back to ON.
5. Special care is required during electrical operation because the manual operation handle moves at high speed. Also be sure to turn off the circuit power supply when using manual operation.
6. With manual operation, ensure that the handle is fully extended.



Manual operation

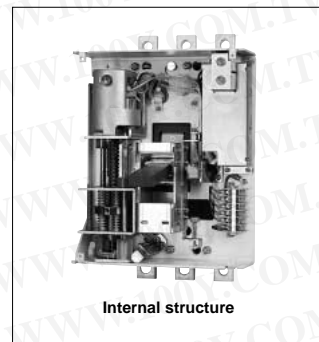

Internal structure

Control circuit

The dotted line shows an additional connection for the automatic-reset type.

(1) Control circuit 1. (400,630 and 800AF)

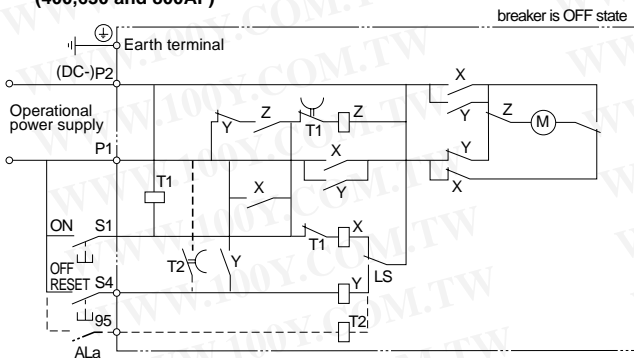

(2) Control circuit 2. (NF1000-SS to NF 1600-SS)

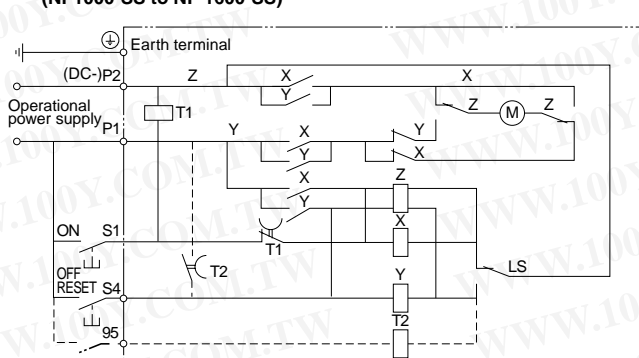

- M :Motor
- X :Relay for ON operation
- Y :Relay for OFF operation
- Z :Relay for changing Motor polarity
- T1 :Timer for antipumping
- T2 :Timer for automatic reset
- LS :Limit Switch
- ALa :Alarm switch for automatic reset (a contact)

Spring-charged type

- Electrical operation

When the ON switch is closed, the coil is excited to release the latch mechanism and the force of the closing spring turns the breaker ON instantly.

When the OFF switch is closed, a relay starts the motor which turns the breaker OFF and charges the spring simultaneously.

- Manual operation

Pressing the ON button will release the latch mechanism and the force of the closing spring turns the breaker ON instantly.

Pressing the leaf spring, pulling out the manual handle and pumping it back and forth over 10 times will turn the breaker OFF and charge the spring at the same time.

- Cautions during electrical operation

Whenever an electrical operation device is to be installed in or removed from the breaker, the breaker must be tripped and the device discharged.

Pushing the TRIP button on an MCCB with an electrical-operation device installed will not trip the breaker in the OFF state. This does not mean the breaker is faulty.

Switching OFF a breaker with an electrical-operation device installed will take 3s. If instant opening is required, install an SHT or UVT to the breaker.

- The breaker contains a built-in pumping-prevention relay.

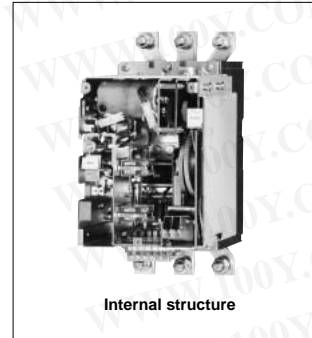

Internal structure

Control circuit

The dotted line shows an additional connection for the automatic-reset type.

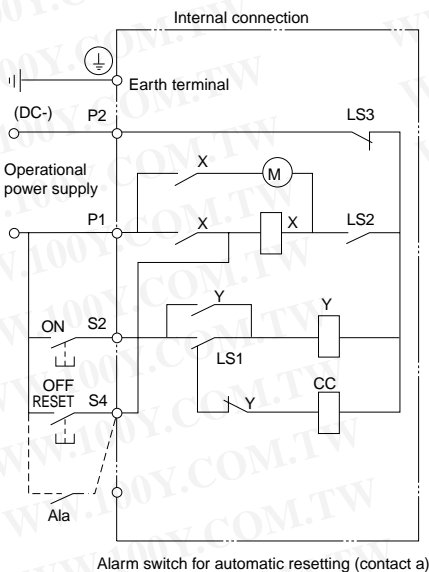

CC.....Coil for making
 Y.....Relay for pumping prevention
 X.....Relay for self-sustaining on OFF side
 LS1...Limit switch interlocking with cam
 LS2...Limit switch interlocking with cam
 LS3...Limit switch interlocking with OFF lock plate
 M.....Motor

Dimensions

Front connection

● NF125-CW, NF125-SW, NF125-HW

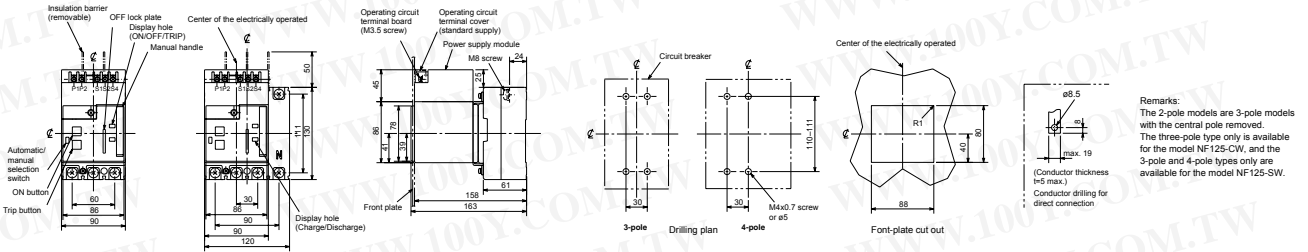

Remarks:
The 2-pole models are 3-pole models with the central pole removed.
The three-pole type only is available for the model NF125-CW, and the 3-pole and 4-pole types only are available for the model NF125-SW.

● NF160-SW, NF160-HW, NF250-CW, NF250-SW, NF250-HW, MB225-SW

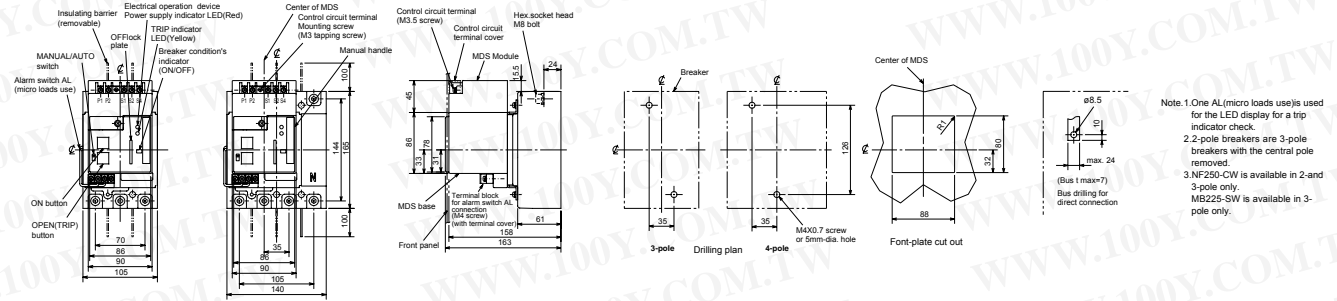

Note. 1. One AL (micro loads use) is used for the LED display for a trip indicator check.
2. 2-pole breakers are 3-pole breakers with the central pole removed.
3. NF250-CW is available in 2- and 3-pole only.
MB225-SW is available in 3-pole only.

● NF125-SGW, NF125-HGW, NF160-SGW, NF160-HGW, NF250-SGW, NF250-HGW

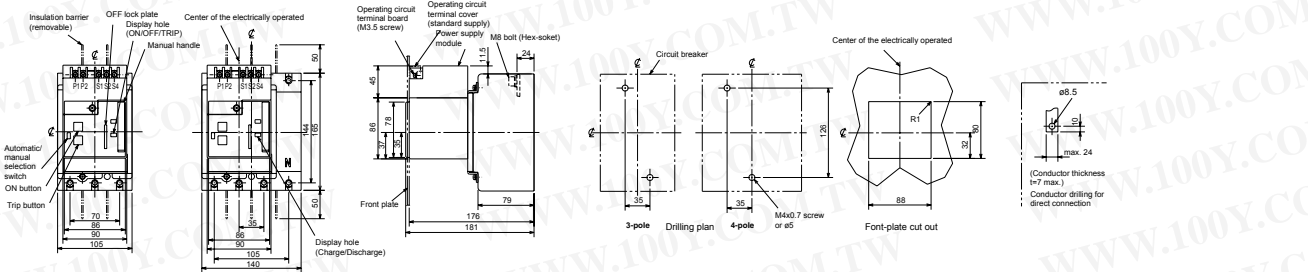

(Conductor thickness $t \leq 7$ max.)
Bus drilling for direct connection

● NV125-CW, NV125-SW, NV125-HW

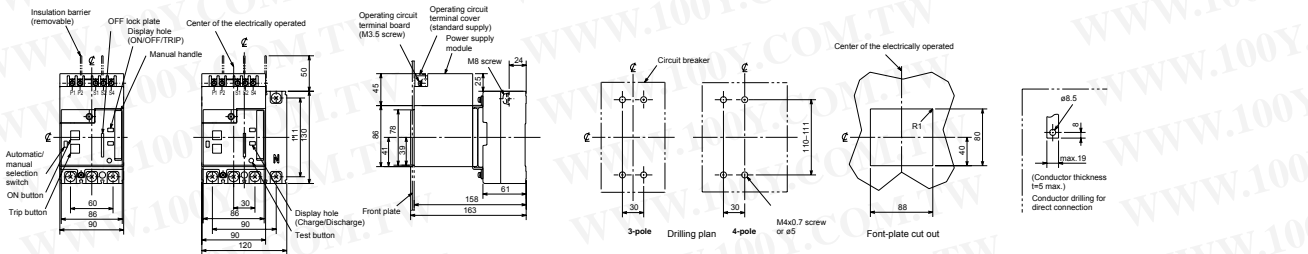

(Conductor thickness $t \leq 5$ max.)
Bus drilling for direct connection

● NV250-SEW, NV250-HEW

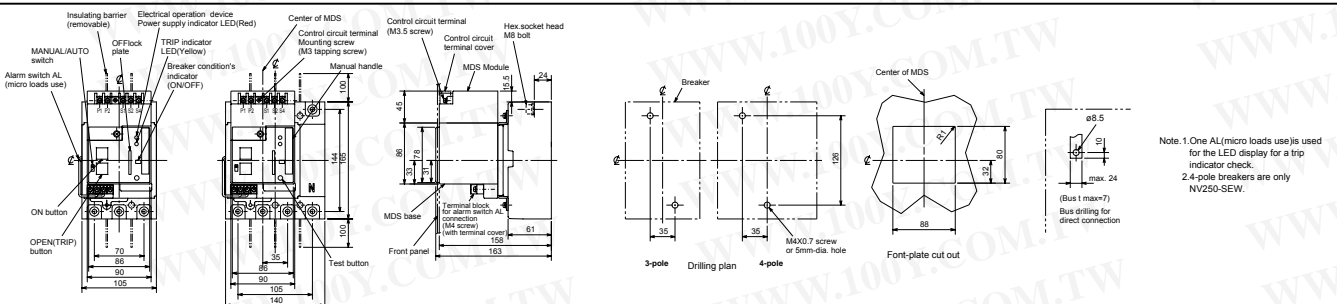

Note. 1. One AL (micro loads use) is used for the LED display for a trip indicator check.
2. 4-pole breakers are only NV250-SEW.

External Accessories

Front connection

● NF400-CP, NF400-SP, NF400-SEP, NF400-HEP, NF400-REP Motor drive type (2)

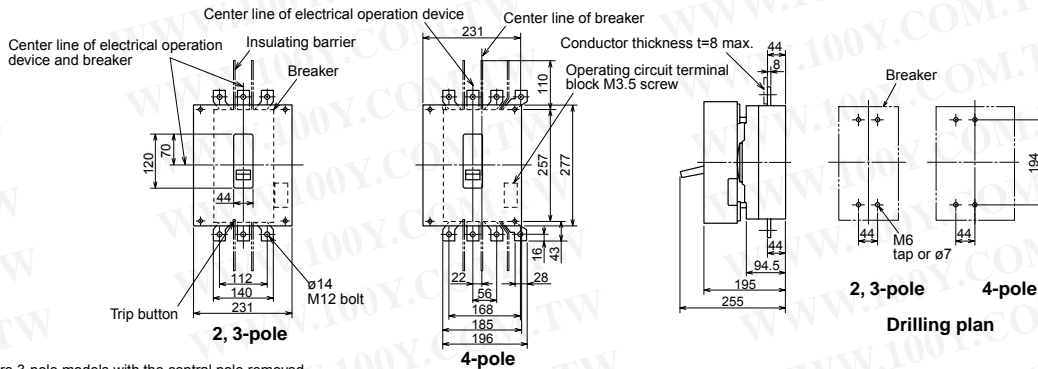

Remark: 2 pole models are 3-pole models with the central pole removed.

● NF400-UEP (3-pole) Motor drive type (2)

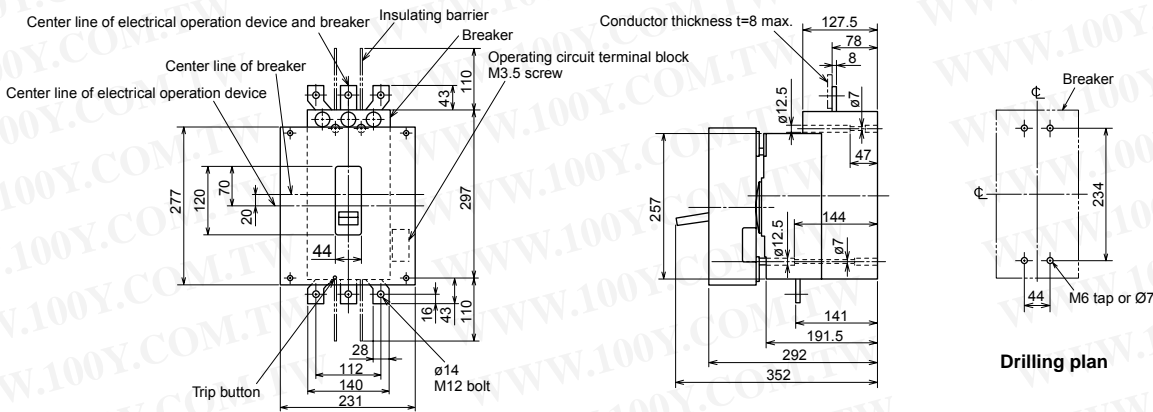

● NV400-CP, NV400-SP, NV400-SEP, NV400-HEP, NV400-REP Motor drive type (2)

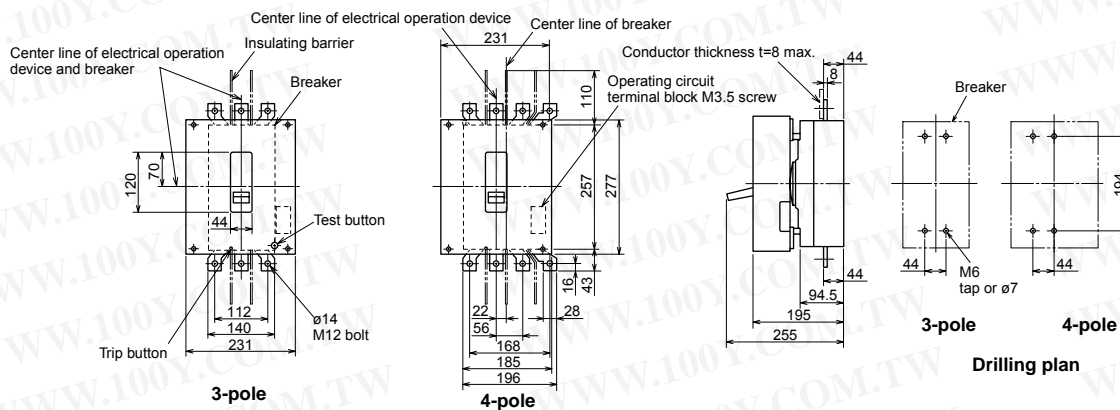

● NF630-CP, NF630-SP, NF630-SEP, NF630-HEP, NF630-REP Motor drive type (2)

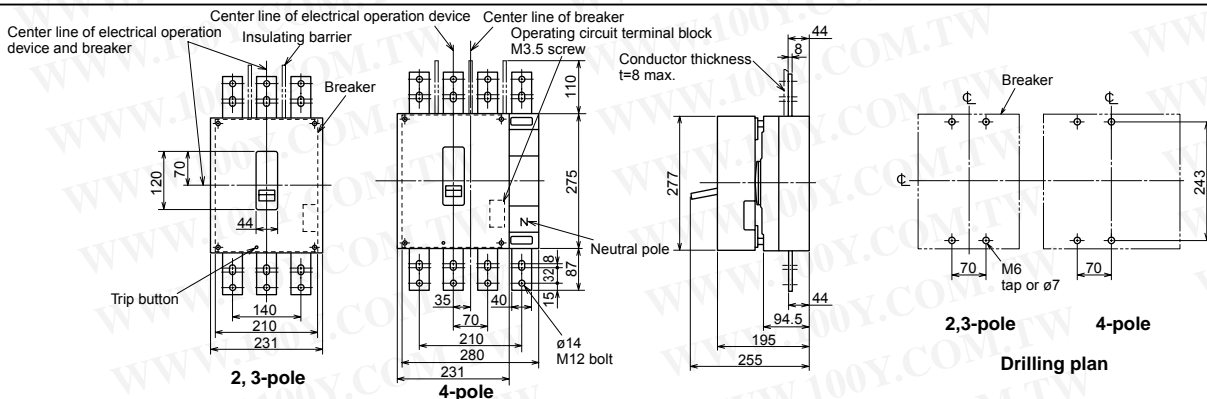

Remark: 2 pole models are 3-pole models with the central pole removed.

Front connection

● NF630-UEP (NF400-UEP 4-pole) Motor drive type (2)

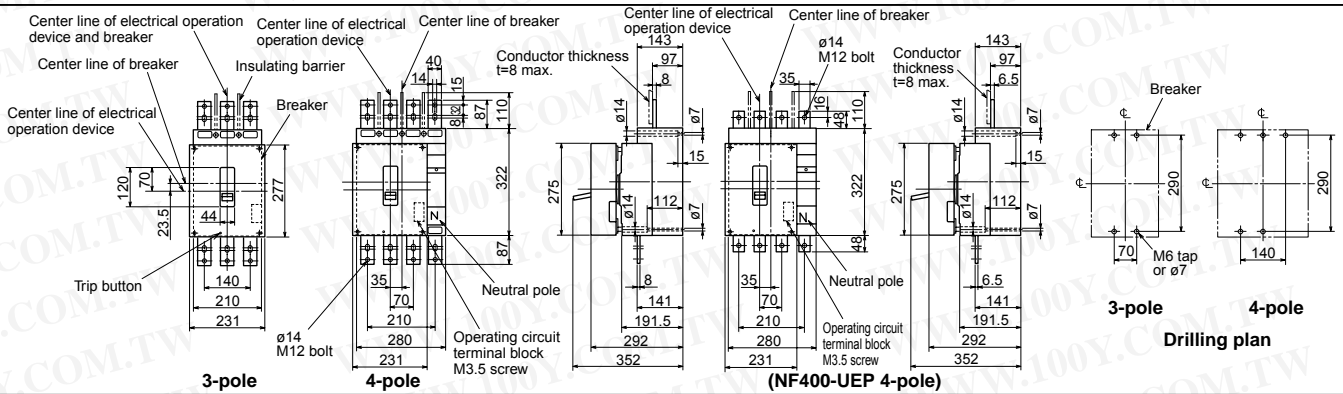

● NV630-CP, NV630-SP, NV630-SEP, NV630-HEP Motor drive type (2)

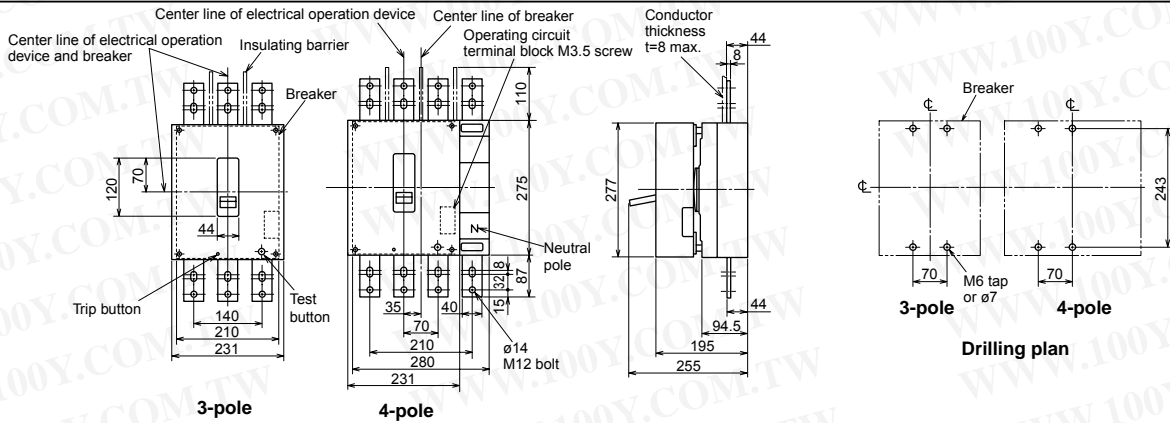

● NF800-CEP, NF800-SDP, NF800-SEP, NF800-HEP, NF800-REP Motor drive type (2)

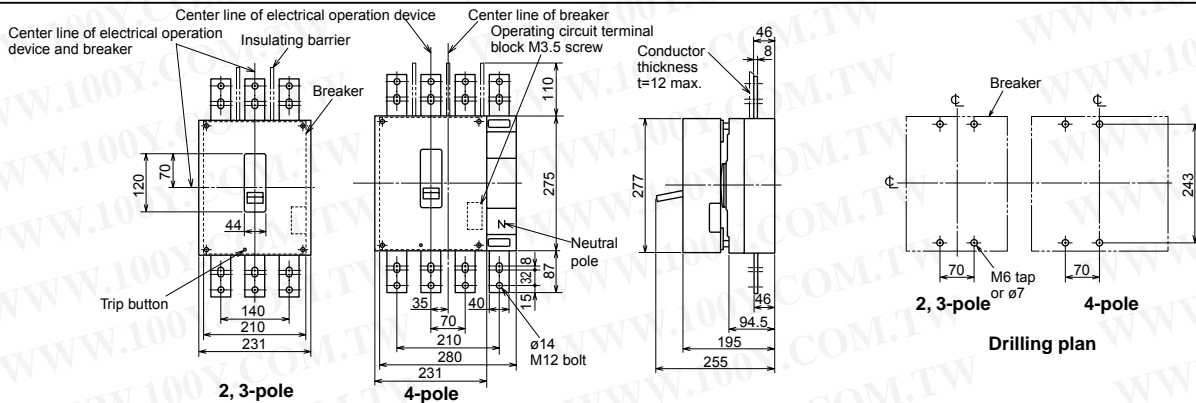

Remark: 2 pole models are 3-pole models with the central pole removed.

● NF800-UEP Motor drive type (2)

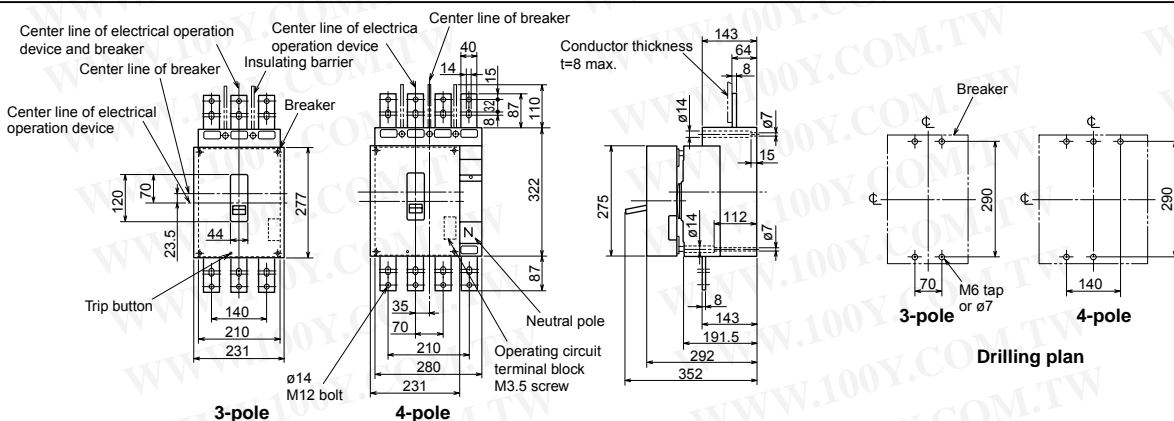

Front connection

● NV800-SEP, NV800-HEP Motor drive type (2)

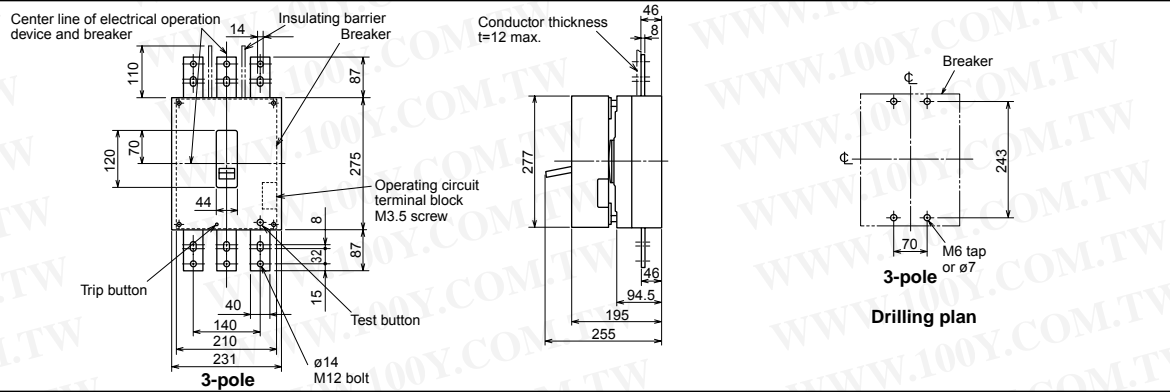

● NF1000-SS, NF1250-SS, NF1000-SSD, NF1250-SSD Motor drive type (2)

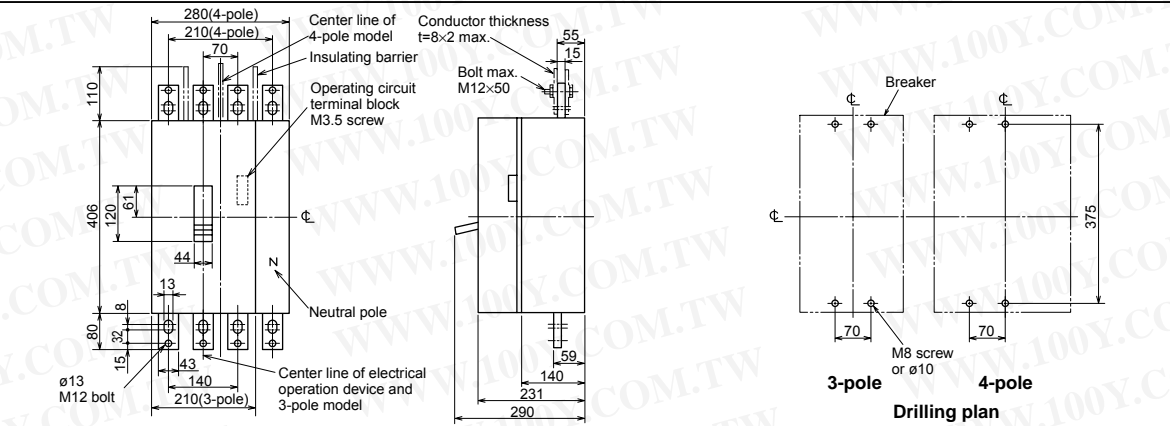

● NF1250-UR Motor drive type (2)

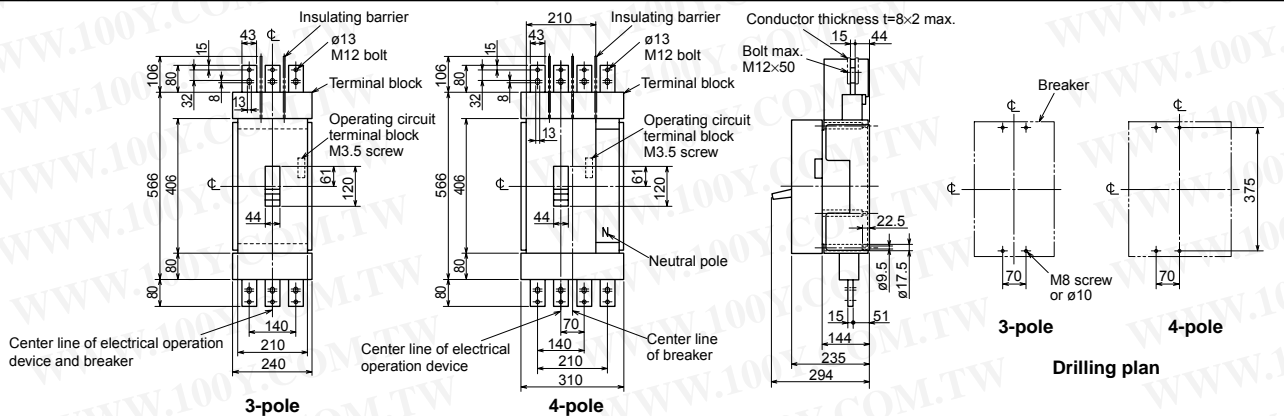

● NF1600-SS, NF1600-SSD Motor drive type (2)

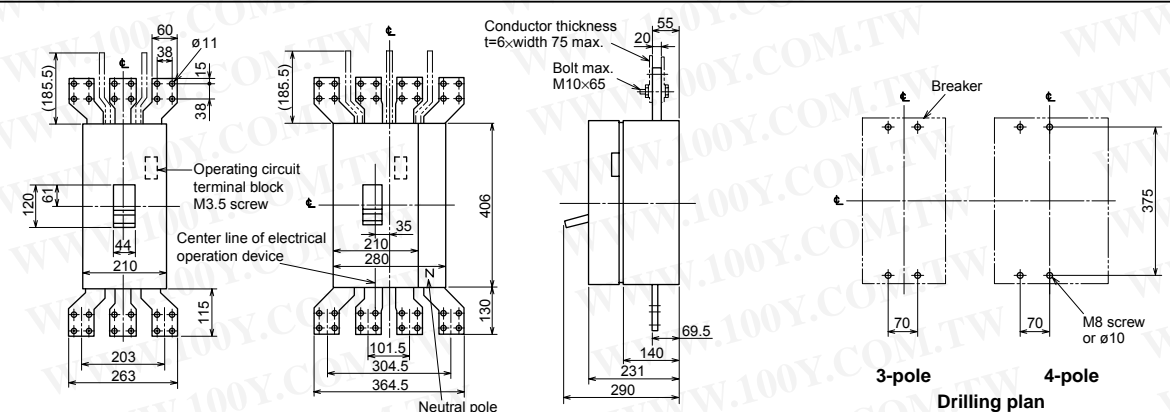

Rear connection

● NF1600-SS (3-pole) Motor drive type (2)

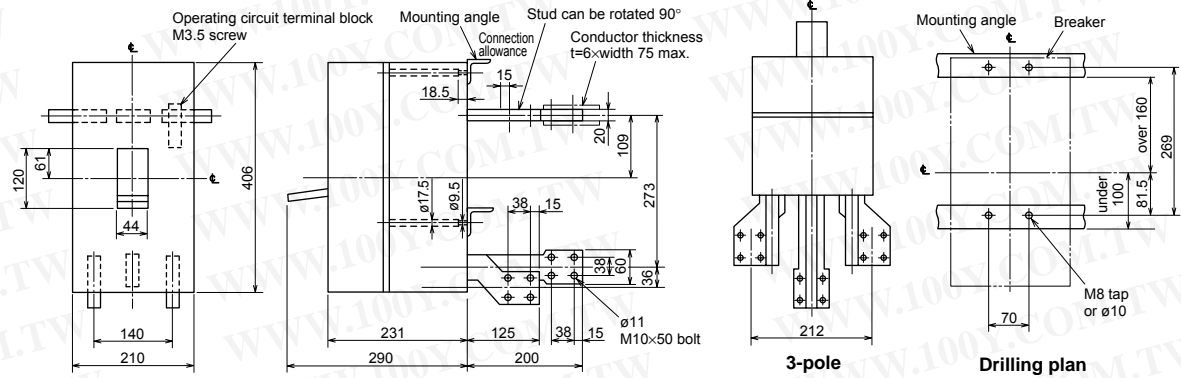

● NF1600-SS (4-pole) Motor drive type (2)

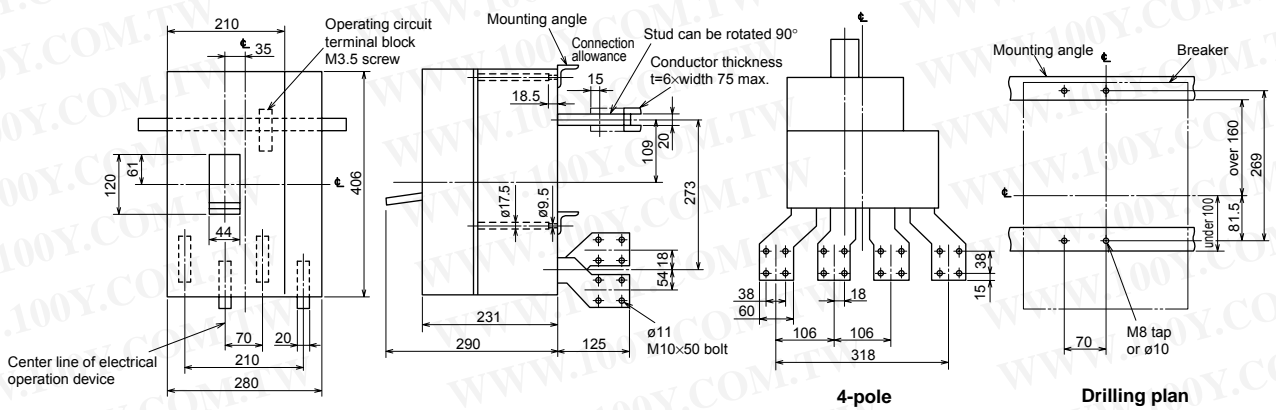

● NF1600-SSD Motor drive type (2)

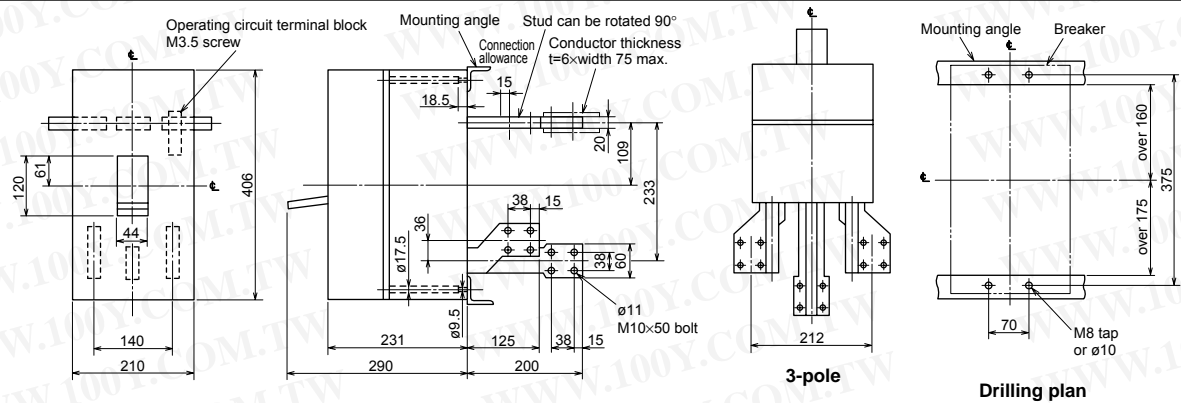

● NF1600-SSD (4-pole) Motor drive type (2)

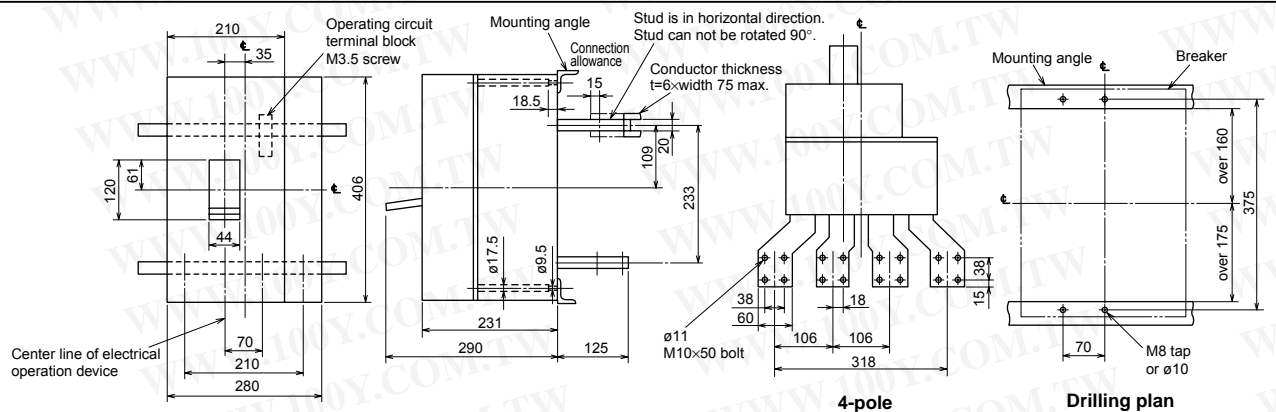

7. Mechanical Interlocks (MI)

Table 5-33

Applicable models	Number of poles	Panel mounting		Direct mount on circuit breaker
		Front connection, Rear connection, Plug-in	Dimension A mm	
NF32-SW, NF63-CW/SW/HW	2P	MI-05SW3	47.5	-
NF32-SW, NF63-CW/SW/HW, NV32-SW, NV63-CW/SW/HW, MB30-SW, MB50-CW/SW	3P		-	MI-05SWFB3
NF63-SW/HW	4P	MI-05SW4	-	-
NF125-CW/SW/HW	2P	MI-05SW3	45	-
NF125-CW/SW/HW, NV125-CW/SW/HW, MB100-SW, NV125-RW	3P			MI-1SWFB3
NF160-SW/HW, NF250-CW/SW/HW, NV250-CW/SW/HW, NV250-SEW/HEW, MB225-SW, NV250-RW	2P	MI-05SW3	-	-
	3P			MI-2SWFB3
NF160-SW/HW, NF250-SW/HW, NV250-SW/HW/SEW/HEW	4P	MI-2SW4	-	-
NF125-SGW/HGW/RGW/UGW, NF160-SGW/HGW, NF250-SGW/HGW/RGW/UGW	3P	MI-05SW3	-	MI-2GSWFB3
NF125-SGW/HGW/UGW, NF160-SGW/HGW, NF250-SGW/HGW/UGW	4P	MI-2SW4	-	-

● **Outside Dimension Diagram**

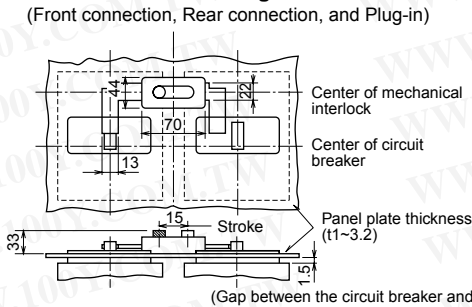

● **Drilling Dimension Diagram**

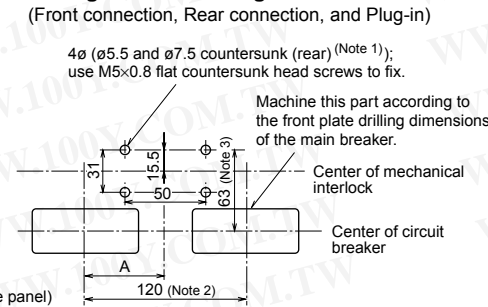

Notes: (1) When the panel plate thickness is 2.3 or more, prepare four holes (ø5.5 and ø9.5 countersunk (rear)).
 (2) These are standard dimensions for 2- and 3-pole models, but can be altered upon request.
 (3) The U series have different dimensions. Please contact us for details.

Remarks: (1) Please contact us for outside dimensions of other models of different specifications.
 (2) These are not isolation-compatible.

● **Front, Rear, Plug-in**

With two breakers, use a panel-mounted mechanical interlock for one-way only input. A breaker-mounting mechanical to mount on the breaker main unit can be made to order. Consult your dealer for more details.

Front, Rear, Plug-in (panel mounting)

Breaker mounting (front)

Type	F	G	P
MI-4SPFB3	44	194	190
MI-6SPFB3	70	243	260

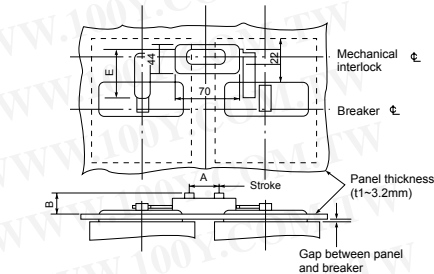

External dimensions

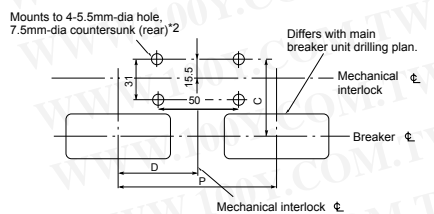

Drilling plan Fig.1

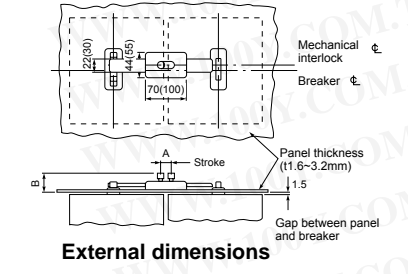

External dimensions

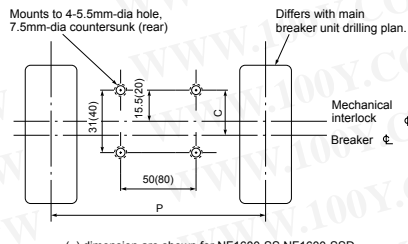

Drilling plan Fig.2

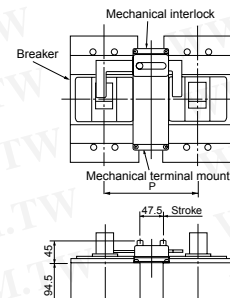

External dimensions

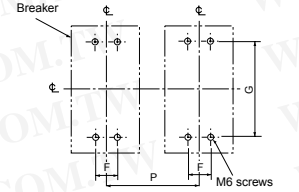

Drilling plan(breaker mount) Fig.3

S1. Above 400AF, use panel thickness t=1.6~3.2mm.
 S2. When the panel thickness is greater than t=2.3mm, use 4-5.5mm-dia 9.5mm dia countersunk (rear).

● **Table of Altered Dimensions**

Table 5-34

Breaker type		Pitch (P) *1					Dimensions (mm)						Breaker mount (#4)	
MCCB	ELCB	Standard		Special Standard	Standard	t	A	B	C (#3)	D	E	Fig.	Type	Fig.
		Type	2P	3P										
NF400-CP/SP/SEP/HEP/REP	NV400-CP/SP/SEP/HEP/REP	MI-4SP3	190	-	210	-	47.5	33	83.5	-	74	Fig.1	MI-4SPFB3	Fig.3
NF400-UEP(3P)	-		-	190	-									
NF630-CP/SP/SEP/HEP/REP, NF800-CEP/SDP/SEP/HEP/REP, NF400-UEP(4P), NF630-UEP, NF800-UEP	NV630-CP/SP/SEP/HEP, NV800-SEP/HEP	MI-6SP3	220	240	-	-	47.5	33	83.5	-	74	Fig.1	MI-6SPFB3	Fig.3
NF1000-SS/SSD, NF1250-SS/SSD	-		M-10SS3	220	-									
NF1250-UR	-	M-12UR3	-	250	-	-	47.5	47	37.5	-	-	Fig.2	-	-
NF1600-SS/SSD	-	M-16SS3	315	-	-	-	65	54.5	39	-	-	-	-	-

*1. Specify the breaker mounting pitch (P)
 *2. No need to specify the panel thickness (t). (Usable panel thickness range: t=1~3.2mm. Above 400AF, use panel thickness t=1.6~3.2mm.)
 *3. For isolation purposes with 400/630/800AF models, keep the C dimension deviation within ±1mm.
 *4. Enquire for more details.
 Remarks: Mechanical interlock walking type (MI-W) for electrical operating can be made to order. Consult your dealer. (Above 400AF)

8. Handle Lock Devices and Card Holder

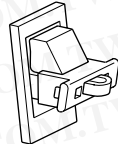
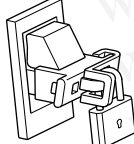
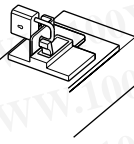
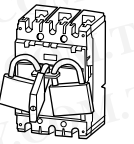
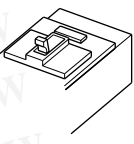
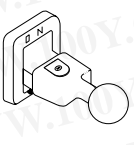

Table 5-35

Description		Lock cover (LC)	Handle lock (HL)	Handle lock (HL-S) (Note 2)	OFF Lock with 3 Padlock	Card holder
Appearance						
NF30-CS, MB30-CS	2P	LC-03CS	HL-05FH	—	—	CH-P No.5
NF30-CS, NV30-CS, MB30-CS	3P					
NF32-SW, NF63-CW/SW/HW	2P					
NF32-SW, NF63-CW/SW/HW, NV32-SW, NV63-CW/SW/HW	3P	LC-05SW	HLF-05SW HLN-05SW	HLS-05SW2P HLS-05SW	—	
NF63-SW/HW	4P					
NF125-CW/SW	2P					
NF125-HW	2P	LC-1SW	HLF-1SW HLN-1SW	HLS-1SW2P HLS-1SW	—	
NF125-CW/SW/HW, NV125-CW/SW/HW	3P					
MB100-SW, NV125-RW	2P					
NF125-SW/HW, NV125-SW/HW	4P	LC-2SW	HLF-2SW HLN-2SW	HLS-2SW	—	
NF160-SW/HW, NF250-CW/SW/HW, NV250-CW/SW/HW	2P					
NV250-SEW/HEW, MB225-SW	3P					
NF125-SGW/HGW, NF160-SGW/HGW, NF250-SGW/HGW	3P, 4P	LC-2GSW	HLF-2GSW (Note 1) HLN-2GSW	HLS-2GSW	HLF3-2GSW	
MB100-SW, NV125-RW	4P					

Notes: (1) HLF types are used for OFF-lock, and HLN types for ON-lock.
 (2) HL-S types are used for OFF-lock.

Remark: (1) Users are requested to prepare padlocks for HL and HL-S types. (25mm padlock for HL, and 35mm padlock for HL-S.)

Table 5-36

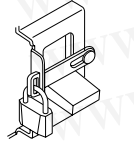
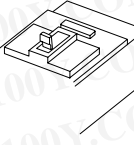
Product	Handle (HT)	Handle lock (HL)	Handle lock (HL-S)	Card holder
Breaker type				
NF400-CP, NV400-CP	HT-4CP	HL-4CP (*1-2)	HLS-4SP (*1)	CH-P No.3
NF400-SP/SEP/HEP/REP/UEP			HLS-4UP (*1)	
NF400-UEP (3P)				
NF400-UEP (4P)	HT-4SP	HL-4SP (*1-2)	HLS-6SP (*1)	
NF630-CP/SP/SEP/HEP/REP/UEP			HLS-6UP (*3)	
NF630-CP/SP/SEP/HEP				
NF800-CEP/SDP/SEP/HEP/REP/UEP	HT-10SS	HL (*1)	—	
NF800-SEP/HEP				
NF1000-SS/SSD				
NF1250-SS/SSD				
NF1250-UR				
NF1600-SS/SSD				

Remarks:

1. Padlocks for HL and HL-S must be provided by the customer.

*1. Must be ordered with breaker.

*2. The HL without padlock can be used as a lock cover (LC).

*3. Applicable types are NF400-UEP (4P) and NF630/800-UEP (3P, 4P).

9. IEC 35mm Rail Mounting Adapters

Table 5-37

Applicable models	Number of poles	Parts number	Outline
NF30-CS, NV30-CS, MB30-CS	2P, 3P	DIN-03CS	Fig.1
NF32-SW, NF63-CW/SW/HW	2P 3P	DIN-05SW	Fig.2
NV32-SW, NV63-CW/SW/HW, MB30-SW			
NF125-CW/SW	2P	DIN-1SW2	Fig.3
	3P	DIN-1SW3	
NF125-HW, NV125-CW/SW/HW, MB100-SW	2P 3P		

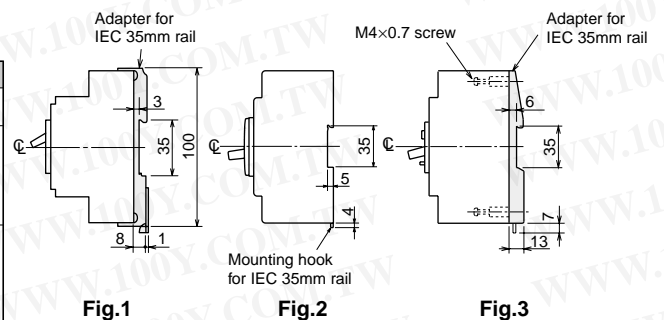

勝特力材料 886-3-5753170
 勝特力电子(上海) 86-21-34970699
 勝特力电子(深圳) 86-755-83298787
[Http://www.100y.com.tw](http://www.100y.com.tw)