

Small Limit Switch D4V

勝特力材料 886-3-5753170
 勝特力电子(上海) 86-21-34970699
 勝特力电子(深圳) 86-755-83298787
[Http://www.100y.com.tw](http://www.100y.com.tw)

Compact Vertical Models Sized for Asian Standards

- Compact new design approximately 1/3 the size of OMRON vertical Limit Switches.
- Structure enables the terminal section to be fully opened for easy wiring.
- RoHS compliant.
- Degree of protection: IP65



Model Number Structure

Model Number Legend

D4V-81□□Z
 1









1. Actuator type

- 04: Roller lever
- 07: Rod lever
- 08: Adjustable roller lever
- 11: Push plunger

- 12: Roller plunger
- 22: Crossroller plunger
- 66: Coil spring
- 69: Wire spring

Ordering Information

List of Models

Actuator type	Model
Roller lever 	D4V-8104Z
Rod lever 	D4V-8107Z
Adjustable roller lever 	D4V-8108Z
Push plunger 	D4V-8111Z
Roller plunger 	D4V-8112Z
Crossroller plunger 	D4V-8122Z
Coil spring 	D4V-8166Z
Wire spring 	D4V-8169Z

Note: Metallic roller levers and metallic variable roller levers can also be manufactured.

Specifications

■ Certified Standards

Certification body	Standard	File No.
CCC	GB14048.5	Consult your OMRON representative for details.
UL (See note.)	UL508, CSA C22.2 No. 14	
TÜV	IEC60947-5-1	

Note: Certification equivalent to CSA C22.2 No. 14 has been obtained from UL.

■ Ratings

Rated voltage (V)	Non-inductive load (A)				Inductive load (A)			
	Resistive load		Lamp load		Inductive load		Motor load	
	NC	NO	NC	NO	NC	NO	NC	NO
125 VAC	5		1.5	0.7	3		2	1
250 VAC	5		1	0.5	3		1.5	0.8
12 VDC	5		3		4		3	
24 VDC	5		3		4		3	
125 VDC	0.4	0.2	---		---		---	
250 VDC	0.4	0.2	---		---		---	

- Note:**
- The above current ratings are for steady-state current.
 - Inductive load has a power factor of 0.4 min. (AC) and a time constant of 7 ms max. (DC).
 - Lamp load has an inrush current of 10 times the steady-state current.
 - Motor load has an inrush current of 6 times the steady-state current.

Inrush current	NC	24 A max.
	NO	12 A max.

■ Ratings for Safety Standard Certification

CCC (GB14048.5), TÜV (EN60947-5-1)

Category and rating
AC-12: 250 VAC at 5 A, resistive load
DC-12: 125 VDC at 0.4 A, resistive load

UL (UL508, CSA C22.2 No. 14)

Ratings
5 A, 250 VAC
0.4 A, 125 VDC

■ Characteristics

Degree of protection		IP65
Durability (See note 3.)	Mechanical	10,000,000 operations min.
	Electrical	300,000 operations min. (5 A at 250 VAC, resistive load)
Operating speed		5 mm to 0.5 m/s
Operating frequency	Mechanical	120 operations/min
	Electrical	30 operations/min
Insulation resistance		100 MΩ min. (at 500 VDC)
Contact resistance		25 mΩ max. (initial value)
Dielectric strength	Between terminals of the same polarity	1,000 VAC, 50/60 Hz for 1 min
	Between current-carrying metal parts and ground	1,500 VAC, 50/60 Hz for 1 min
Rated insulation voltage (Ui)		250 V
Pollution degree (application environment)		3 (EN 60947-5-1)
Short-circuit protection device		10-A fuse, gG or gI (IEC 269)
Conditional short-circuit current		100 A (EN 60947-5-1)
Rated open thermal current (Ith)		5 A (EN 60947-5-1)
Electric shock protection class		Class I
Rated frequency		50/60 Hz
Vibration resistance	Malfunction	10 to 55 Hz, 1.5-mm double amplitude (See note 4.)
	Destruction	1,000 m/s ² (free position) min.
Shock resistance	Malfunction	300 m/s ² (operation limit position) min. (See note 4.)
	Destruction	1,000 m/s ² (free position) min.
Ambient operating temperature range		-20°C to 60°C (with no icing)
Ambient operating humidity range		90% max.
Weight		Approx. 130 to 190 g

- Note:**
- The above values are initial values.
 - The above characteristics may vary depending on the model. Contact your OMRON representative for further details.
 - Durability values are calculated at an operating temperature of 5°C to 35°C, and an operating humidity of 40% to 70%.
 - Except for the coil spring model and wire spring model

Nomenclature

■ Structure

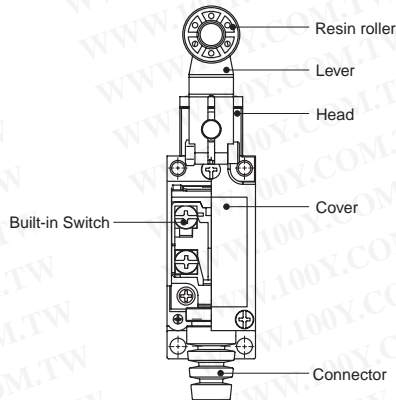

■ Contact Form

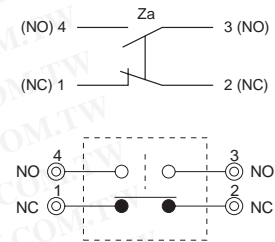

Engineering Data

Electrical Durability: $\cos \phi = 1$

(Ambient temperature: 5°C to 35°C; ambient humidity: 40% to 70%)

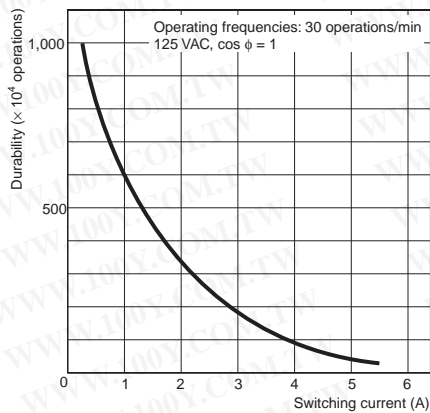

Dimensions

Note: All units are in millimeters unless otherwise indicated.

Roller Lever

D4V-8104Z

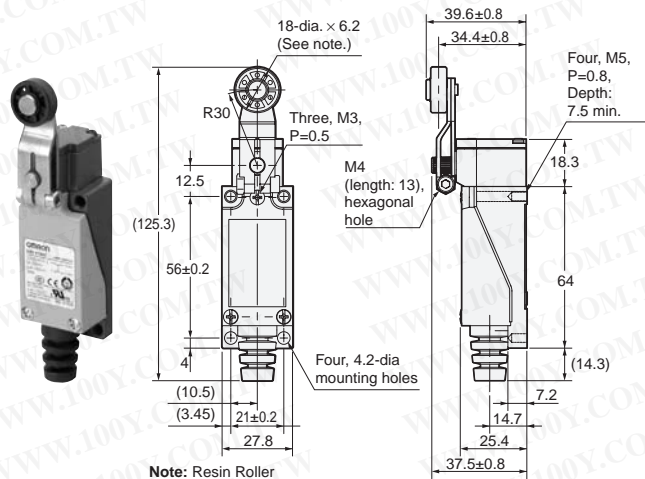

Note: Resin Roller

Rod Lever

D4V-8107Z

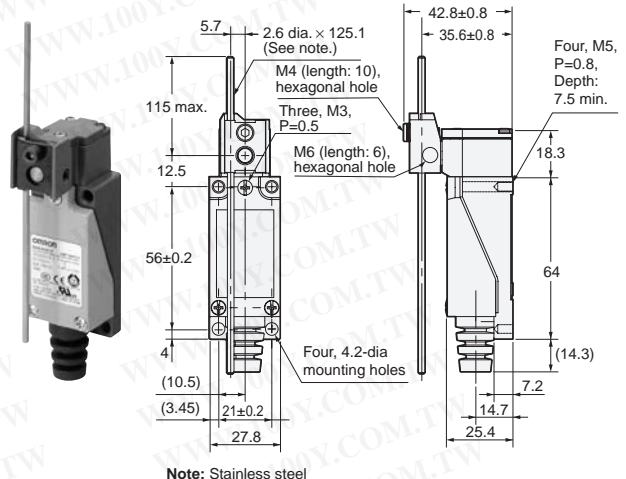

Note: Stainless steel

Adjustable Roller Lever

D4V-8108Z

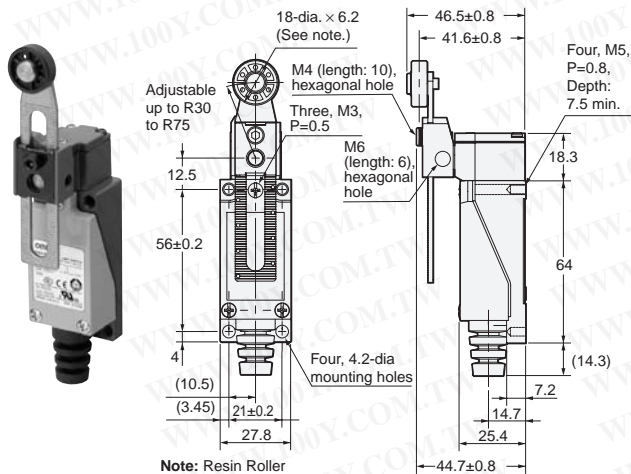

Note: Resin Roller

Push Plunger

D4V-8111Z

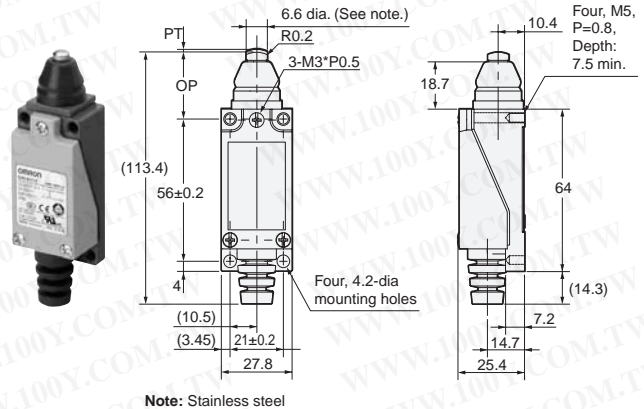

Note: Stainless steel

Roller Plunger

D4V-8112Z

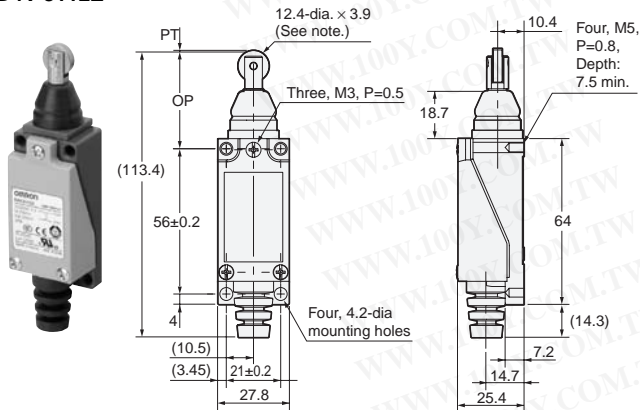

Note: Stainless steel

Crossroller Plunger

D4V-8122Z

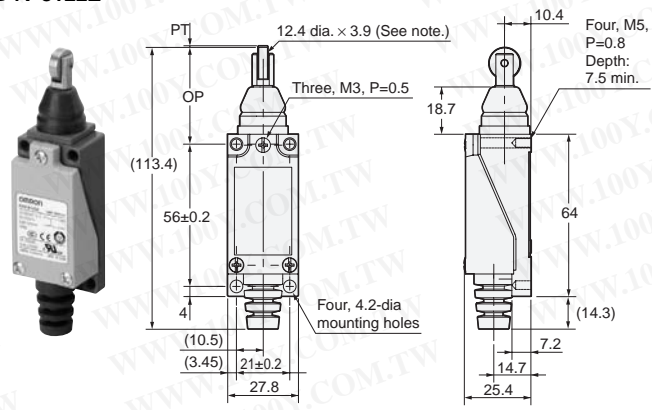

Note: Stainless steel

Coil Spring

D4V-8166Z

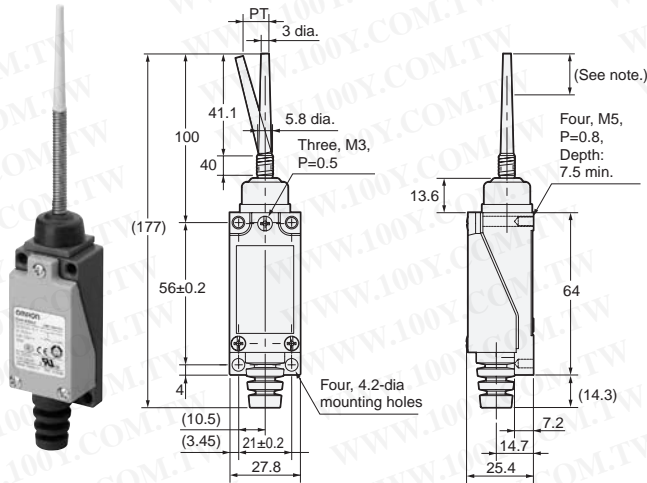

Note: The range for operation is between the tip of the rod and 1/3 of the length of the actuator.

Wire Spring

D4V-8169Z

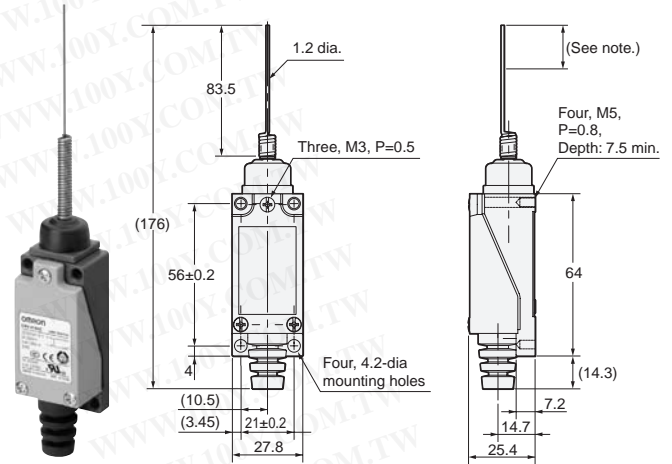

Note: The range for operation is between the tip of the rod and 1/3 of the length of the actuator.

Note: Unless otherwise specified, the tolerances are ± 0.4 mm for the above dimensions for each model.

Operating Characteristics

Operating characteristics	Model	D4V-8104Z	D4V-8107Z	D4V-8108Z	D4V-8111Z	D4V-8112Z	D4V-8122Z	D4V-8166Z	D4V-8169Z
Operating force	OF max.	5.88 N	5.88 N	7.84 N	9.8 N	9.8 N	9.8 N	0.88 N	0.88 N
Release force	RF min.	0.49 N	0.69 N	0.49 N	2.94 N	2.94 N	2.94 N	---	---
Pretravel	PT max.	20°	20°	20°	1.5 mm	1.5 mm	1.5 mm	30 mm	30 mm
Overtravel	OT min.	75°	75°	75°	4 mm	4 mm	4 mm	---	---
Movement differential	MD max.	10°	10°	10°	1.2 mm	1.2 mm	1.2 mm	---	---
Total travel	TT min.	95°	95°	95°	5.5 mm	5.5 mm	5.5 mm	---	---
Operating position	OP	---	---	---	26±0.8 mm	37±0.8 mm	37±0.8 mm	---	---

Note: The operating characteristics of the D4V-8107 are measured with a lever length of 30 mm. The operating characteristics of the D4V-8108 are measured with a lever length of R30.

Precautions

■ Precautions for Correct Use

Wiring

Wiring Procedure

1. Loosen the cover mounting screws and remove the cover.
2. Run the wiring through the rubber connector on the cover and then press-fit the solderless terminals. (The following solderless terminals are available.)
3. After inserting the solderless terminal into the Switch, tighten the terminal screws securely.
4. Mount the cover. (Make sure that the rubber connector is securely pressed into the cover slot.)
5. Tighten the three screws evenly. (The optimum tightening torque for each screw is 0.49 to 0.59 N·m.)

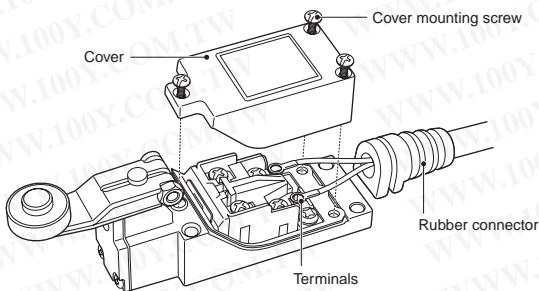

Applicable Lead Wires

Wire name	Applicable wire		
	Number of conductors	Conductor size	Finished outside diameter
Vinyl cabtire cord (VCTF)	2 conductors 3 conductors 4 conductors	0.75 mm ²	Round, 6 to 9 dia.
Vinyl cabtire cable (VCT)	2 conductors	0.75 mm ²	
600-V vinyl-insulated sheath cable (VVF)	2 conductors	1 dia., 1.2 dia., 1.6 dia.	

Note: Do not use wires containing silicone, otherwise a contact failure may result.

Applicable Terminals

The following solderless terminals can be used. (Do not use fork or any other type of terminals, otherwise an accidental disconnection resulting in a ground fault may result.)

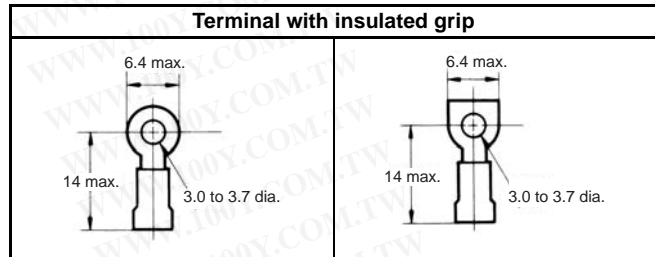

Appropriate Tightening Torque

If screws are too loose, they can lead to an early malfunction of the Switch, so ensure that all screws are tightened using the correct torque.

No.	Type	Appropriate tightening torque
1	Head mounting screw	0.49 to 0.59 N·m
2	Cover mounting screw	0.49 to 0.59 N·m
3	Lever mounting screw	2.45 to 2.94 N·m
4	Terminal screw (M3)	0.49 to 0.59 N·m
5	Switch mounting screw (M4 Allen-head bolt)	2.45 to 2.94 N·m

Note: In particular, when changing the direction of the Head, make sure that all screws are tightened again to the correct torque. Be careful not to allow any foreign substance to enter the Switch.

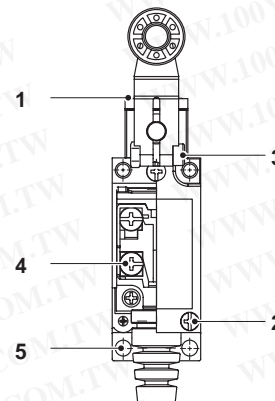

Mounting

1. Front Surface Mounting

1. Through-hole Panel Mounting

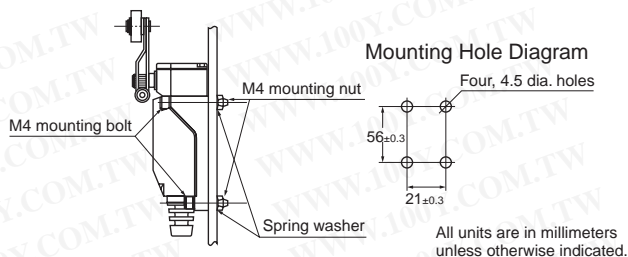

2. Tap Panel Mounting

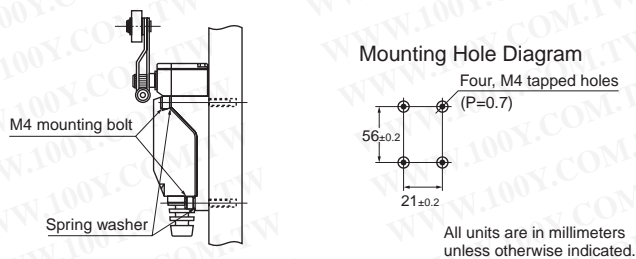

2. Rear Surface Mounting

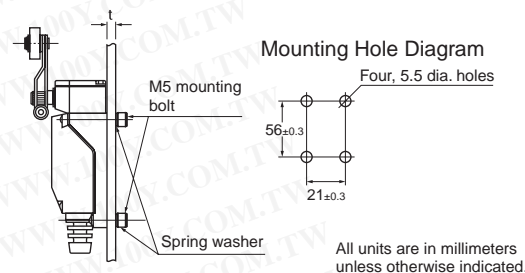

Note: The tap screws for the body are M5, P=0.8, with a minimum depth of 7.5 mm. Use bolts with a length of the panel thickness $t + 7$ mm or less.

Others

- Do not use the Limit Switch outdoors, otherwise the Limit Switch will be damaged by rust or ozone.
- The Limit Switch is not suitable in places exposed to the spray of rainwater, seawater, or oily water. Contact your OMRON representative if such specifications are required.
- If high-sealing performance is required along with shielded wiring or conduit wiring, use the D4C or WL.

Using the Switch

Changing the Actuator Mounting Position

(D4V-8104Z, D4V-8108Z, D4V-8107Z)

By loosening the Allen-head bolt on the actuator lever, the position of the actuator can be set anywhere within the 360°.

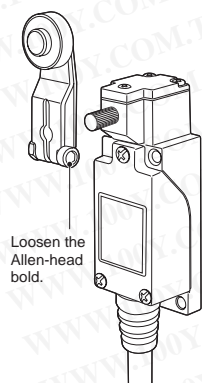

Changing the Head Direction

(D4V-8104Z, D4V-8107Z, D4V-8108Z)

By loosening one screw (black) at a time, the head can be changed at 90° increments in any of the four directions.

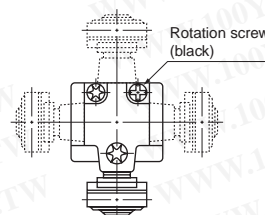

Operation

- Operate the coil spring and wire spring models between the tip of the actuator and 1/3 the length of the actuator and parallel to the direction of operation.
- Handling the bottom of the actuator or excessively pushing in the tip may lead to bending damage, deformation, malfunction, and deterioration of service life.
- Contact bouncing, chattering, or telegraphing may occur. Take steps so that incorrect signals are not detected on the circuit side if doing so will cause problems with the application.

Note: Telegraphing refers to the phenomenon of the actuator being used and bouncing back after the operating body has passed, and moving to the operation point on the opposite side, which causes the contact to operate.