

# REED SWITCH

## ORT551

Ultraminiature Transfer

勝特力材料 886-3-5753170  
勝特力电子(上海) 86-21-34970699  
勝特力电子(深圳) 86-755-83298787  
[Http://www.100y.com.tw](http://www.100y.com.tw)

### ■ GENERAL DESCRIPTION

The OR551 is a ultraminiature two-contacts reed switch designed for transfer type operation. The contacts are sealed within the glass tube with inert gas to maintain contact reliability.

### ■ FEATURES

- (1) Reed contacts are hermetically sealed within a glass tube with inert gas and do not receive any influence from the external atmospheric environment.
- (2) Quick response
- (3) The structure comprises the operating parts and electrical circuits arranged coaxially. Reed switches are suited to applications in radio frequency operation.
- (4) Reed switches are compact and light weight.
- (5) Superior corrosion resistance and wear resistance of the contacts assures stable switching operation and long life.
- (6) With a permanent magnet installed, reed switches economically and easily become proximity switches.

### ■ EXTERNAL DIMENSIONS (Unit: mm)

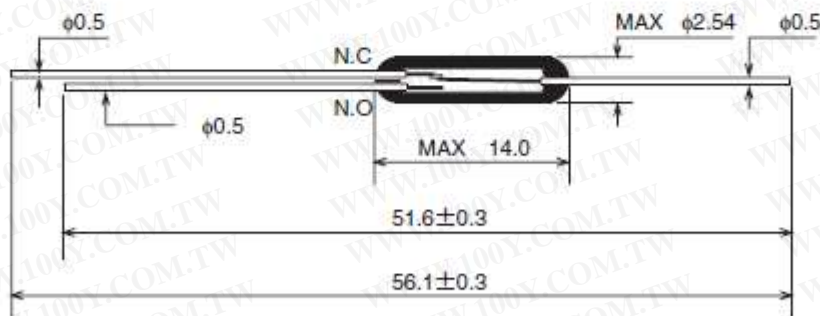

### ■ APPLICATIONS

- Automotive electronic devices
- Control equipment
- Communication equipment
- Measurement equipment
- Household appliances

■ ELECTRICAL CHARACTERISTICS

Parameter	Rated value	Unit
Pull-in Value (PI)	10~30	AT
Drop-out Value (DO)	4min	AT
Contact resistance (CR)	100max	mW
Breakdown voltage	200min (PI ≥ 20)	VDC
	150min (PI < 20)	VDC
Insulation resistance	10 <sup>9</sup> min	W
Electrostatic capacitance	1.5max	pF
Contact rating	3	VA
Maximum switching voltage	30 (DC) AC	V
Maximum switching current	0.2	A
Maximum carry current	0.5	A

(1) Drop-out Value vs. Pull-in Value

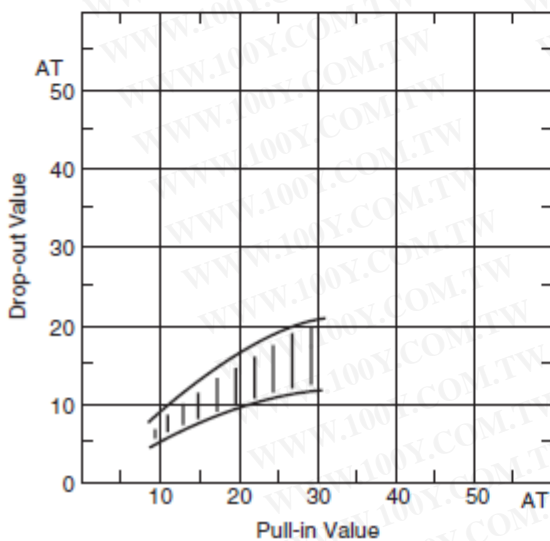

(2) Contact resistance

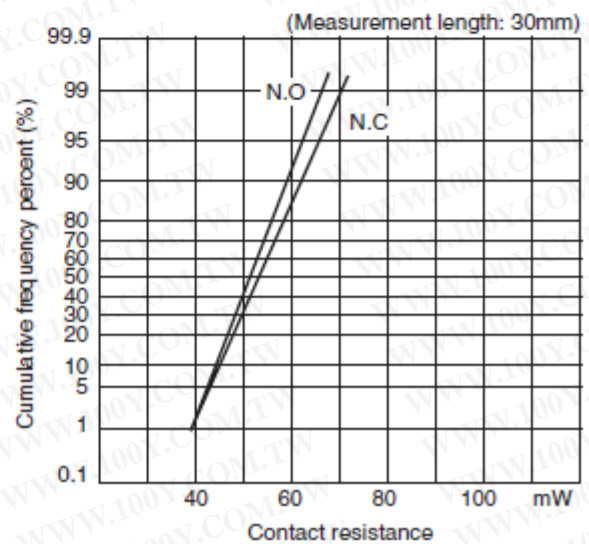

(3) Breakdown voltage

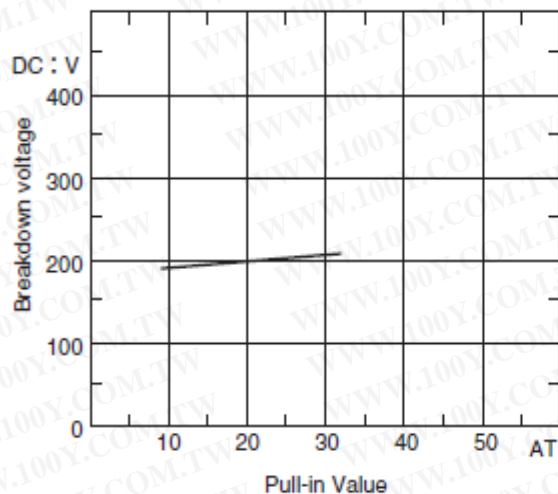

(4) Insulation resistance

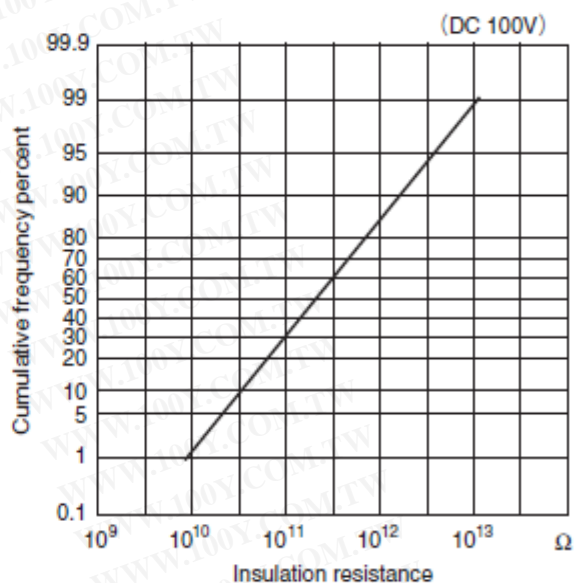

(5) Electrostatic capacitance

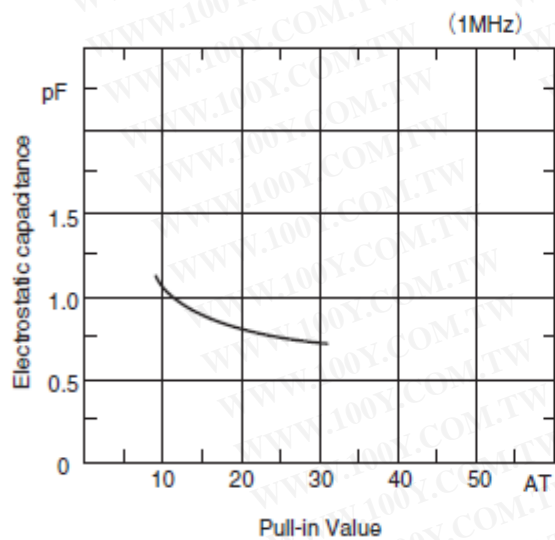

■ OPERATING CHARACTERISTICS

Parameter	Rated value	Unit
Operate time	1.0max	ms
Bounce time	NO 1.0max	ms
	NC 1.5max	ms
Release time	0.5max	ms
Resonant frequency	6000±4000	Hz
Maximum operating frequency	200	Hz

(1) Operate time

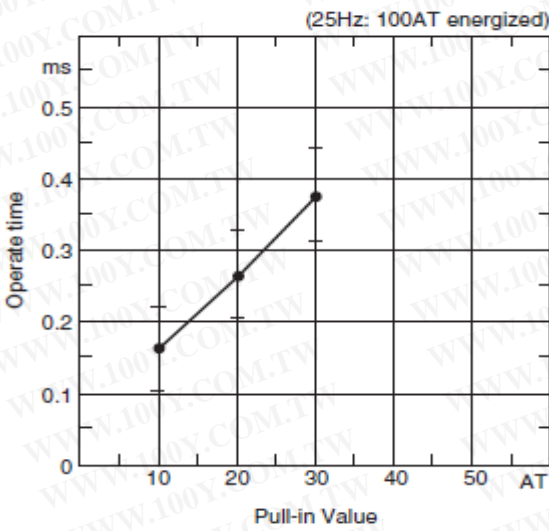

(2) Bounce time

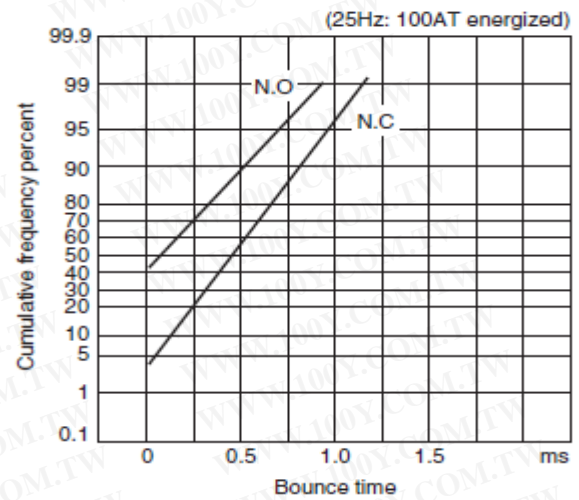

(3) Release time

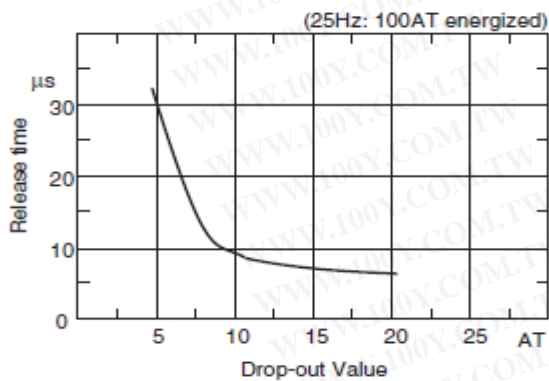

(4) Resonant frequency

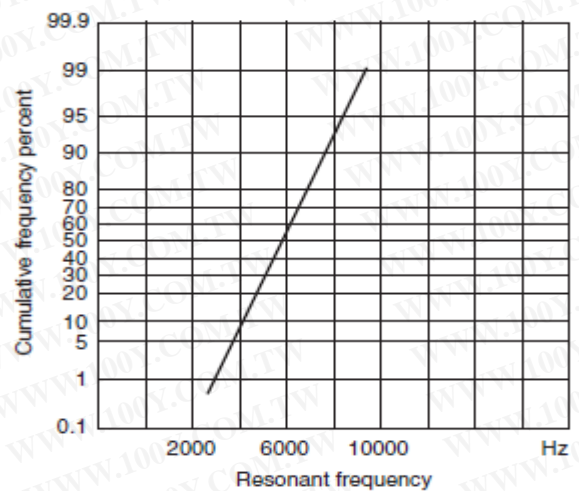

■ MECHANICAL CHARACTERISTICS

(1) Lead tensile test (static load)

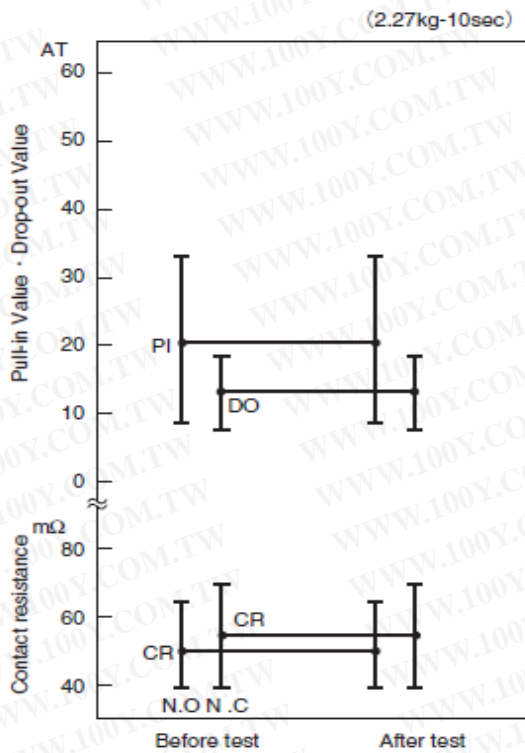

(2) Lead tensile strength

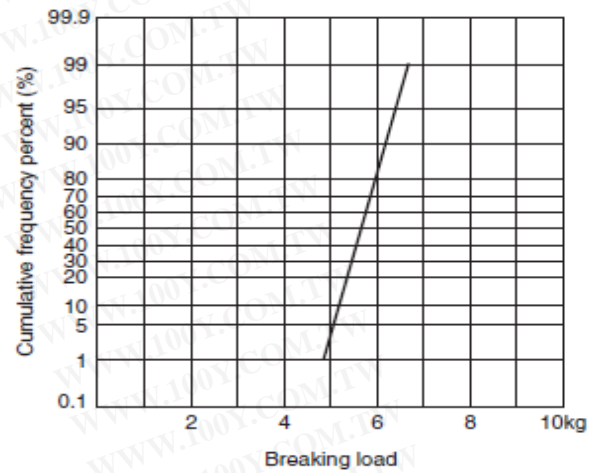

■ ENVIRONMENTAL CHARACTERISTICS

(1) Temperature characteristics

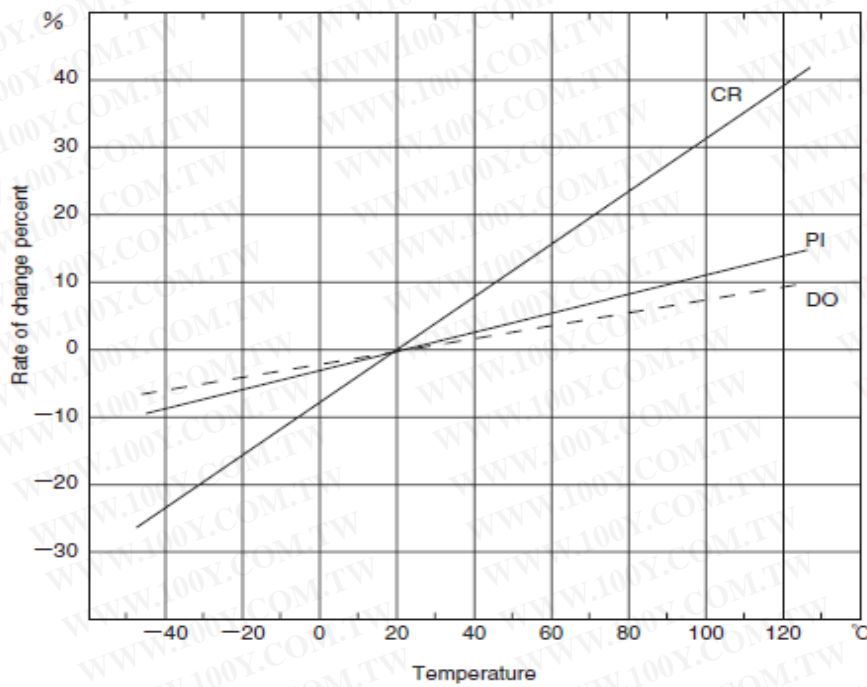

(2) Temperature cycle

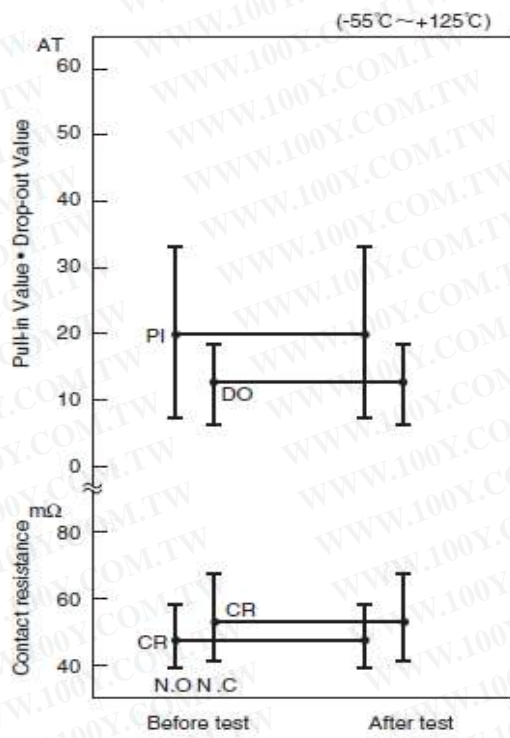

(3) Temperature and humidity cycle

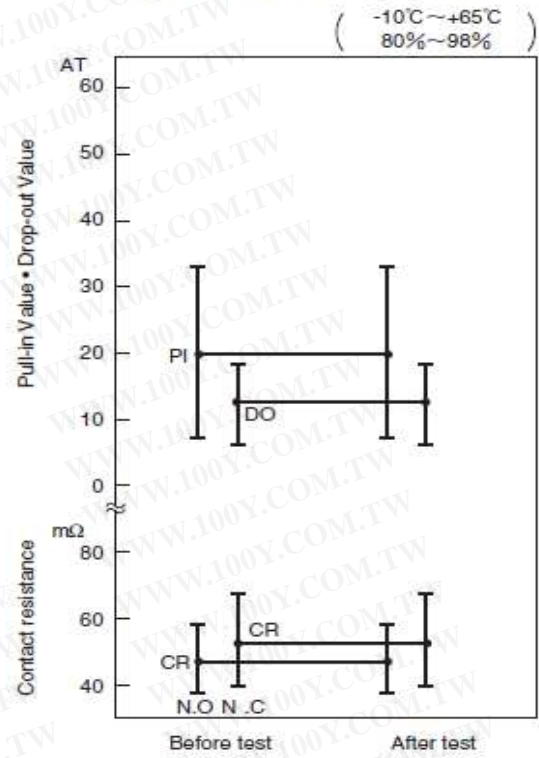

(4) High temperature storage test

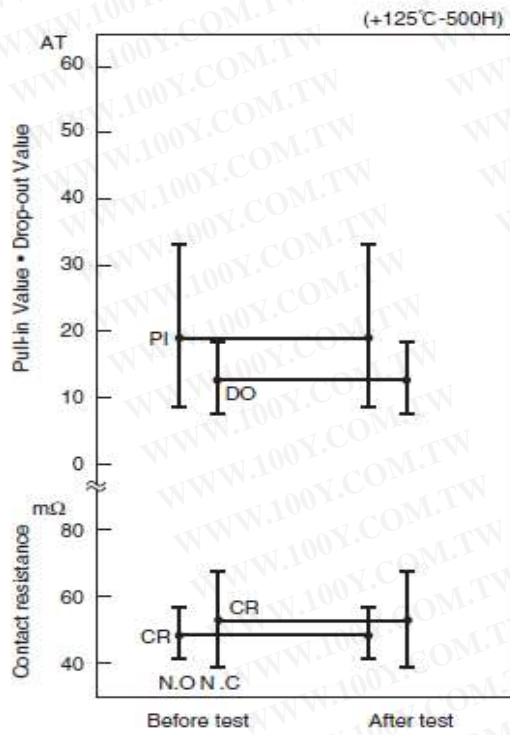

(5) Low temperature storage test

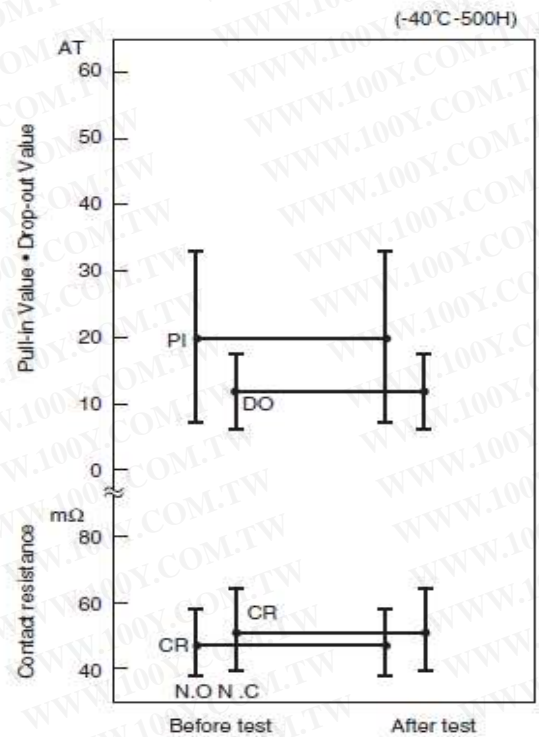

(6) Shock test

1) Electrical characteristics

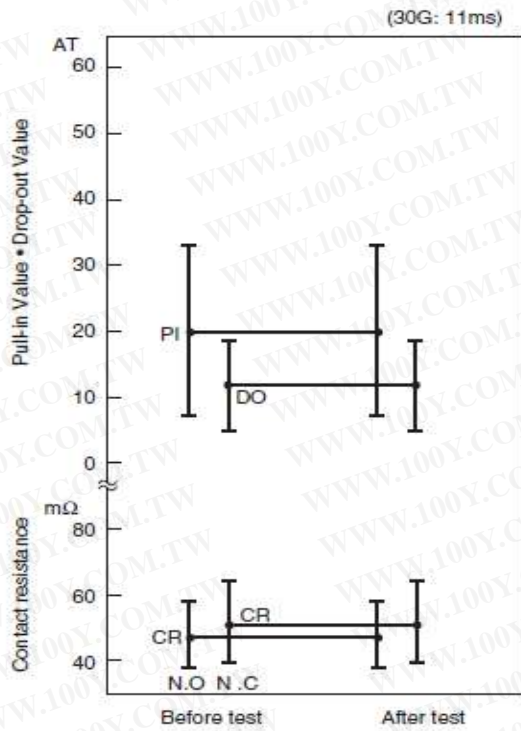

2) Misoperation area

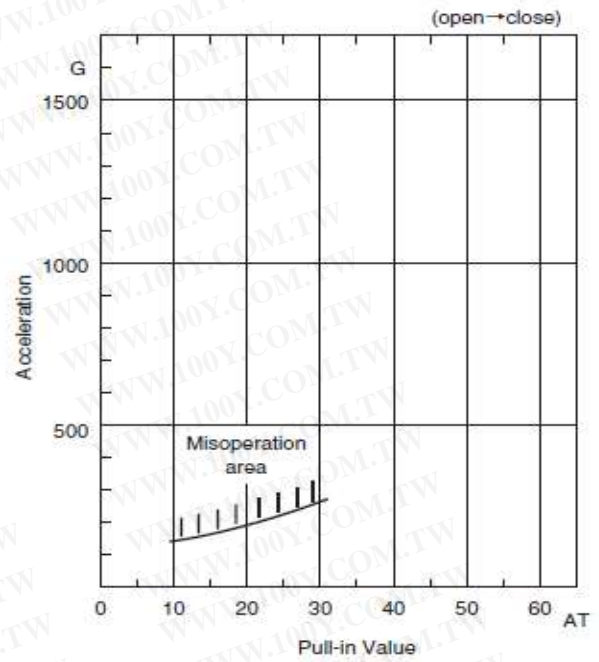

(7) Vibration test

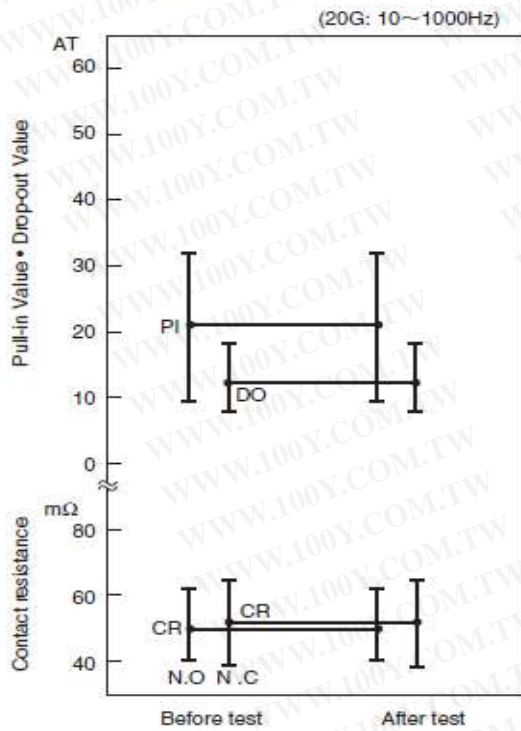

■ LIFE EXPECTANCY DATA: ORT551

Load conditions  
 Voltage: 5VDC  
 Current: 100 $\mu$ A, 1mA, 5mA  
 Load: Resistive load

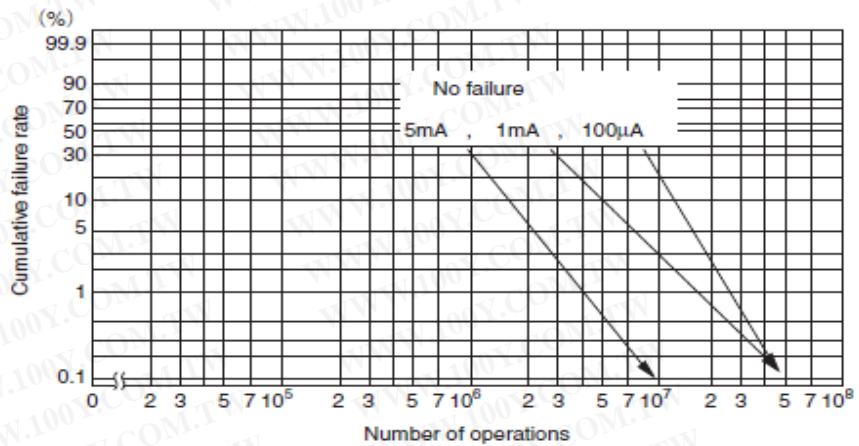

\* Arrow indicates number of operations where test was completed.

Load conditions  
 Voltage: 12VDC  
 Current: 5mA, 10mA, 100mA  
 Load: Resistive load

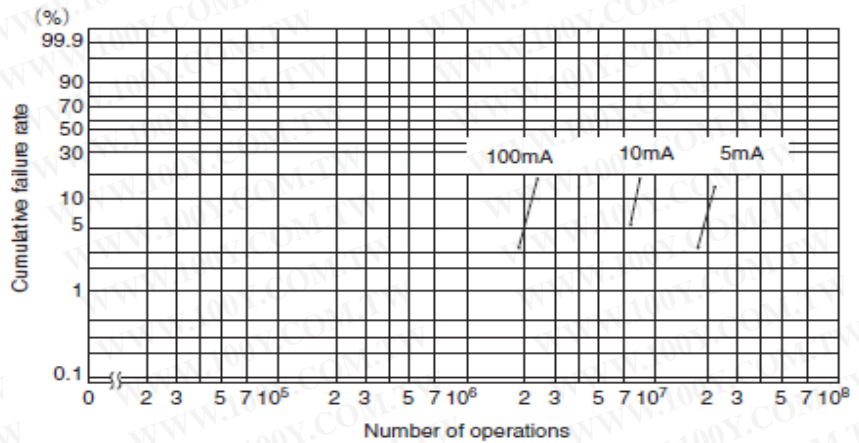

Load conditions  
 Voltage: 24VDC  
 Current: 50mA, 100mA  
 Load: Resistive load

