

Auto Switch Mounting Brackets/Part No.

Auto switch model	Bore size (mm)			
	ø20	ø25	ø32	ø40
D-M9□(V) D-M9□W(V) D-A9□(V)	BM5-020 (A set of a, b, c, d)	BM5-025 (A set of a, b, c, d)	BM5-032 (A set of a, b, c, d)	BM5-040 (A set of a, b, c, d)
D-M9□A(V) <small>Note 2)</small>	BM5-020S (A set of b, c, d, e)	BM5-025S (A set of b, c, d, e)	BM5-032S (A set of b, c, d, e)	BM5-040S (A set of b, c, d, e)

D-H7□ D-H7□W D-H7NF D-C7□/C80 D-C73C/C80C	BM2-020A (A set of band and screw)	BM2-025A (A set of band and screw)	BM2-032A (A set of band and screw)	BM2-040A (A set of band and screw)
D-H7BA	BM2-020AS (A set of band and screw)	BM2-025AS (A set of band and screw)	BM2-032AS (A set of band and screw)	BM2-040AS (A set of band and screw)
D-B5□/B64 D-B59W D-G5NT	BA2-020 (A set of band and screw)	BA2-025 (A set of band and screw)	BA2-032 (A set of band and screw)	BA2-040 (A set of band and screw)
D-A3□A/A44A <small>Note 3)</small> D-G39A/K39A	BM3-020 (A set of band and screw)	BM3-025 (A set of band and screw)	BM3-032 (A set of band and screw)	BM3-040 (A set of band and screw)

Note 1) Since the switch bracket (made from nylon) are affected in an environment where alcohol, chloroform, methylamines, hydrochloric acid or sulfuric acid is splashed over, so it cannot be used. Please contact SMC regarding other chemicals.

Note 2) As the indicator LED is projected from the switch unit, indicator LED may be damaged if the switch bracket is fixed on the indicator LED.

Note 3) The D-A3□A/A44A/G39A/K39A cannot be mounted on the centralized piping type CDM2□P series.

Band Mounting Brackets Set Part No.

Set part no.	Contents
BM2-□□□A(S) * S: Stainless steel screw	<ul style="list-style-type: none"> • Auto switch mounting band (c) • Auto switch mounting screw (d)
BJ4-1	<ul style="list-style-type: none"> • Switch bracket (White/PBT) (e) • Switch holder (b)
BJ5-1	<ul style="list-style-type: none"> • Switch bracket (Transparent/Nylon) (a) • Switch holder (b)

勝特力材料 886-3-5753170
 勝特力电子(上海) 86-21-34970699
 勝特力电子(深圳) 86-755-83298787
[Http://www.100y.com.tw](http://www.100y.com.tw)

Other than the applicable auto switches listed in “How to Order”, the following auto switches are mountable.

Refer to the **WEB catalog** or the Best Pneumatics No. 2 for the detailed specifications.

Type	Model	Electrical entry	Features
Solid state	D-H7A1, H7A2, H7B	Grommet (In-line)	—
	D-H7NW, H7PW, H7BW		Diagnostic indication (2-color indication)
	D-H7BA		Water resistant (2-color indication)
	D-G5NT		With timer
Reed	D-B53, C73, C76	Grommet (In-line)	—
	D-C80		Without indicator light

* With pre-wired connector is also available for solid state auto switches. For details, refer to the **WEB catalog** or the Best Pneumatics No. 2.

* Normally closed (NC = b contact) solid state auto switches (D-F9G/F9H) are also available. For details, refer to the **WEB catalog** or the Best Pneumatics No. 2.

Series CG1

Auto Switch Mounting Brackets/Part No.

Auto switch model	Bore size (mm)							
	20	25	32	40	50	63	80	100
D-M9□(V) D-M9□W(V) D-A9□(V)	BMA3-020 (A set of a, b, c, d)	BMA3-025 (A set of a, b, c, d)	BMA3-032 (A set of a, b, c, d)	BMA3-040 (A set of a, b, c, d)	BMA3-050 (A set of a, b, c, d)	BMA3-063 (A set of a, b, c, d)	—	—
D-M9□A(V) <small>Note 2)</small>	BMA3-020S (A set of b, c, d, e)	BMA3-025S (A set of b, c, d, e)	BMA3-032S (A set of b, c, d, e)	BMA3-040S (A set of b, c, d, e)	BMA3-050S (A set of b, c, d, e)	BMA3-063S (A set of b, c, d, e)	—	—

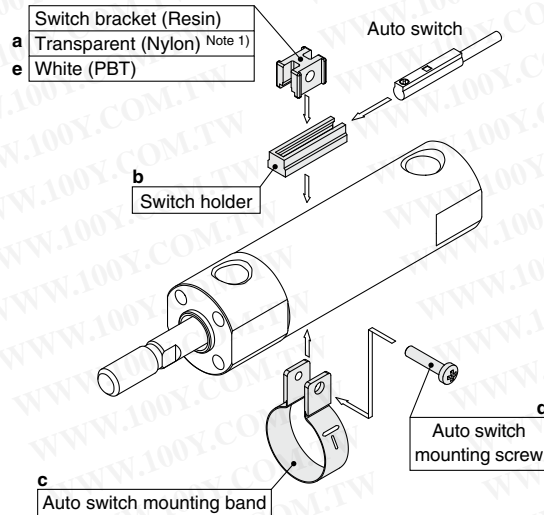

* Band (c) is mounted so that the projected part is on the internal side (contact side with the tube).

D-H7□ D-H7□W D-H7NF D-C7□/C80 D-C73C/C80C	BMA2-020A (A set of band and screw)	BMA2-025A (A set of band and screw)	BMA2-032A (A set of band and screw)	BMA2-040A (A set of band and screw)	BMA2-050A (A set of band and screw)	BMA2-063A (A set of band and screw)	—	—
D-H7BA	BMA2-020AS (A set of band and screw)	BMA2-025AS (A set of band and screw)	BMA2-032AS (A set of band and screw)	BMA2-040AS (A set of band and screw)	BMA2-050AS (A set of band and screw)	BMA2-063AS (A set of band and screw)	—	—
D-G5□/K59 D-G5□W/K59W D-G5BA/G59F D-G5NT D-B5□/B64 D-B59W D-G5NB	BA-01 (A set of band and screw)	BA-02 (A set of band and screw)	BA-32 (A set of band and screw)	BA-04 (A set of band and screw)	BA-05 (A set of band and screw)	BA-06 (A set of band and screw)	BA-08 (A set of band and screw)	BA-10 (A set of band and screw)

Note 1) Since the switch bracket (made from nylon) are affected in an environment where alcohol, chloroform, methylamines, hydrochloric acid or sulfuric acid is splashed over, so it cannot be used.

Please contact SMC regarding other chemicals.

Note 2) As the indicator LED is projected from the switch unit, indicator LED may be damaged if the switch bracket is fixed on the indicator LED.

Band Mounting Brackets Set Part No.

Set part no.	Contents
BMA2-□□□A(S) * S: Stainless steel screw	· Auto switch mounting band (c) · Auto switch mounting screw (d)
BJ4-1	· Switch bracket (White/PBT) (e) · Switch holder (b)
BJ5-1	· Switch bracket (Transparent/Nylon) (a) · Switch holder (b)

[Stainless Steel Mounting Screw]

The following stainless steel mounting screw kit is available. Use it in accordance with the operating environment.

(Since the auto switch mounting bracket is not included, order it separately.)

BBA3: D-B5/B6/G5/K5 types

Note 3) Refer to the **WEB catalog** or the Best Pneumatics No. 2 for details on the BBA3.

When the D-G5BA type auto switch is shipped independently, the BBA3 is attached.

Operating Range

Auto switch model		Bore size [mm]		
		6	10	16
Band mounting	D-M9□/M9□V D-M9□W/M9□WV D-M9□A/M9□AV	2	2.5	3
	D-A9□	4.5	6	7
	D-H7□/H7□W D-H7BA/H7NF	3	4	4
	D-H7C	5	8	9
	D-C7□/C80/C73C/C80C	6	7	7
	Rail mounting	D-M9□/M9□V D-M9□W/M9□WV D-M9□A/M9□AV	—	3
D-A9□/A9□V		—	6	6.5
D-F7□/J79/F7□W/J79W D-F7□V/F7□WV/F79F D-J79C/F7BA/F7BAV D-F7NT		—	5	5
D-A7□/A80/A7H/A80H D-A73C/A80C		—	8	9
D-A79W		—	11	13

*: Values which include hysteresis are for guideline purposes only, they are not a guarantee (assuming approximately ±30% dispersion) and may change substantially depending on the ambient environment.

Auto Switch Mounting Brackets/Part No.

Auto switch mounting	Auto switch model	Bore size [mm]		
		6	10	16
Band mounting	D-M9□ D-M9□V D-M9□W D-M9□WV D-A9□ D-A9□V	BJ6-006 (A set of a, b, d, f)	BJ6-010 (A set of a, b, c, d)	BJ6-016 (A set of a, b, c, d)
	D-M9□A *2 D-M9□AV *2	BJ6-006S (A set of a, b, d, g)	BJ6-010S (A set of a, b, d, e)	BJ6-016S (A set of a, b, d, e)
Band mounting				
Band mounting	D-H7□/H7□W D-H7BA/H7NF D-C7□/C80 D-C73C/C80C	BJ2-006 (A set of band and screw)	BJ2-010 (A set of band and screw)	BJ2-016 (A set of band and screw)
Rail mounting	*4 D-M9□ D-M9□V D-M9□W D-M9□WV D-M9□A *4 D-M9□AV *4 D-A9□ D-A9□V		BQ2-012 (S) (A set of a and b)	BQ2-012 (S) (A set of a and b)

*1: Since the switch bracket (made from nylon) are affected in an environment where alcohol, chloroform, methylamines, hydrochloric acid or sulfuric acid is splashed over, so it cannot be used. Please contact SMC regarding other chemicals.

*2: As the indicator LED is projected from the auto switch unit, indicator LED may be damaged if the switch bracket is fixed on the indicator LED.

*3: When the cylinder is shipped, the auto switch mounting bracket and the auto switch will be included.

*4: For D-M9□A(V), order the BQ2-012S, which uses stainless steel mounting screws.

Band Mounting Brackets Set Part No.

Set part no.	Contents	Bore size [mm]		
		6	10	16
BJ2-□□□	• Auto switch mounting band (a) • Auto switch mounting screw (b)	BJ2-006	BJ2-010	BJ2-016
BJ4-1	• Switch bracket (White/PBT) (e) • Switch holder (d)	—	●	●
BJ4-2	• Switch bracket (Black/PBT) (g) • Switch holder (d)	●	—	—
BJ5-1	• Switch bracket (Transparent/Nylon) (c)*1 • Switch holder (d)	—	●	●
BJ5-2	• Switch bracket (Transparent blue/Nylon) (f)*1 • Switch holder (d)	●	—	—

[Stainless Steel Mounting Screw]

The following stainless steel mounting screw kit is available. Use it in accordance with the operating environment. (Since the auto switch mounting bracket is not included, order it separately.)

BBA4: For D-C7/C8/H7 types

*5: Refer to the **WEB catalog** or the Best Pneumatics No. 2 for details on the BBA4.

When the D-H7BA type auto switch is shipped independently, the BBA4 is attached.

Series NCM

Auto Switch Mounting

Auto Switch Mounting Bracket Part No.

Auto switch model	Bore size							
	044	056	075	088	106	125	150	200
D-M9□(V) D-M9□W(V) D-A9□(V)	Note 1) ① BJ2-012 ② BJ3-1	Note 1) ① BJ2-015 ② BJ3-1	Note 1) ① NBM2-075 ② BJ3-1	Note 1) ① NBM2-088 ② BJ3-1	Note 1) ① NBM2-106 ② BJ3-1	Note 1) ① NBM2-125 ② BJ3-1	Note 1) ① NBM2-150 ② BJ3-1	Note 1) ① NCMB-200 ② BJ3-1
D-H7□ D-H7□W D-H7BAL D-H7NF D-C7□/80 D-C73C/80C	BJ2-012	BJ2-015	NBM2-075	NBM2-088	NBM2-088	NBM2-125	NBM2-150	NCMB-200
D-G5NTL D-B5□/B59W/B64	-	-	NBA-075	NBA-088	NBA-106	NBA-125	NBA-150	NCMA-200

Note 1) Two types of auto switch mounting brackets are used as a set.

Note 2) D-G5NTL, B5□, B64, B59W cannot be mounted on models with bore size 044 and 056.

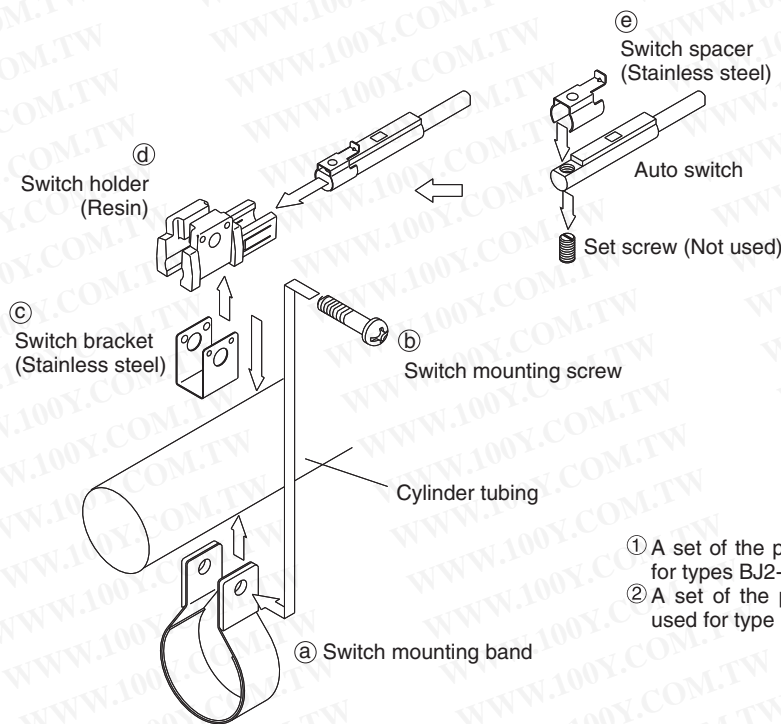

- ① A set of the parts marked (a) and (b) in the diagram is used for types BJ2-□□□, NBM2-□□□, and NCMB-200.
- ② A set of the parts marked (c), (d) and (e) in the diagram is used for type BJ3-1.

Stainless steel screw set

The set of stainless steel mounting screws described below is available and can be used depending on the operating environment. As auto switch bracket is not included, order separately.

Detailed Contents of Stainless Steel Mounting Screw Sets

Part no.	Content			Applicable auto switch mounting bracket part no.	Applicable auto switch
	Description	Size	Qty.		
BBA3	Auto switch mounting screw	M4X0.7X22L	1	NBA-075/088/106/125/150 NCMA-200	D-G5NTL D-B5□□ D-B64
BBA4	Auto switch mounting screw	M3X0.5X14L	1	BJ2-012/015 NBM2-075/088/106/125/150 NCMB-200	D-H7□□ D-C7□□ D-C80□

D-H7BAL switch is set on the cylinder with the stainless steel screws (BBA4) above when shipped. When only a switch is shipped independently, BBA4 screws are attached.

C85/C75 Series

Auto Switch Mounting Bracket/Set Part Nos.

Auto switch mounting	Auto switch model	C85 Series						C75 Series	
		Bore size [mm]							
		ø8	ø10	ø12	ø16	ø20	ø25	ø32	ø40
	D-M9□(V) D-M9□W(V) D-A9□(V)*7	BJ6-008 (A set of a, b, c, d)	BJ6-010 (A set of a, b, c, d)	BJ6-012 (A set of a, b, c, d)	BJ6-016 (A set of a, b, c, d)	BM5-020 (A set of a, b, c, d)	BM5-025 (A set of a, b, c, d)	BM5-032 (A set of a, b, c, d)	BM5-040 (A set of a, b, c, d)
	D-M9□A(V)	BJ6-008S (A set of a, b, c, e) (Screw: Stainless steel)	BJ6-010S (A set of a, b, c, e) (Screw: Stainless steel)	BJ6-012S (A set of a, b, c, e) (Screw: Stainless steel)	BJ6-016S (A set of a, b, c, e) (Screw: Stainless steel)	BM5-020S (A set of a, b, c, e) (Screw: Stainless steel)	BM5-025S (A set of a, b, c, e) (Screw: Stainless steel)	BM5-032S (A set of a, b, c, e) (Screw: Stainless steel)	BM5-040S (A set of a, b, c, e) (Screw: Stainless steel)
*1 *2 *3 *4 Band mounting									
	D-C7□/C80 D-C73C/C80C D-H7□/H7□W D-H7BA/H7NF	BJ2-008 (A set of a and b)	BJ2-010 (A set of a and b)	BJ2-012 (A set of a and b)	BJ2-016 (A set of a and b)	BM2-020A (A set of a and b)	BM2-025A (A set of a and b)	BM2-032A (A set of a and b)	BM2-040A (A set of a and b)
*5 *6 Rail mounting	D-M9□(V)*8 D-M9□W(V)*8 D-M9□A(V)*8 D-A9□(V)*7	BQ2-012 (S) (A set of f and g)							

- *1 Since the switch bracket for band mounting (made from nylon) are affected in an environment where alcohol, chloroform, methylamines, hydrochloric acid or sulfuric acid is splashed over, so it cannot be used. Please contact SMC regarding other chemicals.
- *2 In the case of band mounting auto switches, make sure the indicator LED is not directly below switch mounting bracket when mounted as the protruding LED may be damaged.
- *3 For band mounting, switch brackets are mounted on the cylinder when small switches are specified. (switches are not mounted, but packaged together).
- *4 For band mounting, when specifying the switches other than the small switches, auto switch(s) are mounted on the cylinder.
- *5 For rail mounting, the auto switches and auto switch mounting brackets are packed together (not assembled).
- *6 For rail mounting, when D-M9□A(V) is ordered separately, select the stainless steel mounting screw set BQ2-012S.
- *7 When mounting a band and/or a rail on bore size ø8, ø10 or ø12 cylinder, D-A9□(V) type cannot be mounted.
- *8 When mounting a rail on bore size ø20 or ø25 cylinder, D-M9□(V), M9□W(V) and M9□A(V) types cannot be mounted.

Auto Switch Mounting Bracket/Single Unit Part Nos.

Auto switch model	C85 Series						C75 Series		Parts lineup
	ø8	ø10	ø12	ø16	ø20	ø25	ø32	ø40	
D-M9□(V) D-M9□W(V) D-A9□(V)	BJ2-008	BJ2-010	BJ2-012	BJ2-016	BM2-020A	BM2-025A	BM2-032A	BM2-040A	· Auto switch mounting band (a) · Auto switch mounting screw (b)
	BJ5-2	BJ5-1							· Switch holder (c) · Switch bracket (d)
D-M9□A(V)	BJ2-008S	BJ2-010S	BJ2-012S	BJ2-016S	BM2-020AS	BM2-025AS	BM2-032AS	BM2-040AS	· Auto switch mounting band (a) · Auto switch mounting screw (b)
	BJ4-2	BJ4-1							· Switch holder (c) · Switch bracket (e)

[Stainless Steel Mounting Screw]

The following stainless steel mounting screw kit is available. Use it in accordance with the operating environment. (Since the auto switch mounting bracket is not included, order it separately.)

BBA4: For D-C7/C8/H7 types

- * Refer to the **Web Catalog** or Best Pneumatics No. 2-1 for details on the BBA4.
- When the D-H7BA type auto switch is shipped independently, the BBA4 is attached.

Other than the applicable auto switches listed in "How to Order", the following auto switches are mountable.

Refer to Best Pneumatics No. 2-1 for the detailed specifications.

Type	Model	Electrical entry	Features	Mounting	Applicable bore size
Reed	D-C73, C76	Grommet (In-line)	—	Band	ø8 to ø25
	D-C80		Without indicator light		
Solid state	D-H7A1, H7A2, H7B	Grommet (In-line)	—	Band	ø8 to ø25
	D-H7NW, H7PW, H7BW		Diagnostic indication (2-color indicator)		

- * Normally closed (NC = b contact) solid state auto switches (D-F9G/F9H) are also available. For details, refer to Best Pneumatics No. 2-1.
- * With pre-wired connector is also available for solid state switches. For details, refer to Best Pneumatics No. 2-1.

4 Auto Switch Mounting Brackets/Part No.

Applicable Cylinder Series: CDQP2, CDQP2□□□□□□S/-□□ (Axial piping)

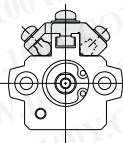
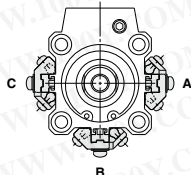
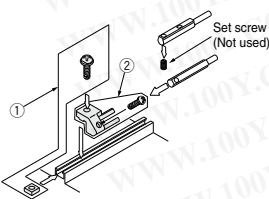
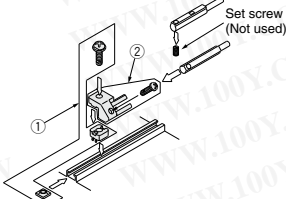
Auto switch mounting surface	Bore size (mm)	
	ø12, ø16, ø20, ø25	ø32 to ø100
		
Auto switch model	Auto switch mounting surface Auto switch mounting rail side only	Auto switch mounting surface A/B/C side
D-A9□ D-A9□V D-M9□ D-M9□V D-M9□W D-M9□WV D-M9□A D-M9□AV	① BQ-1 ② BQ2-012 Two kinds of auto switch brackets are used as a set.	① BQ-2 ② BQ2-012 Two kinds of auto switch brackets are used as a set.
		

Note 1) When shipping cylinders, auto switch mounting brackets and auto switches are shipped together.

Auto switch model	Bore size (mm)		
	ø12 to ø25	ø32	ø40 to ø100
D-A7□/A80 D-A73C/A80C D-A7□H/A80H D-A79W D-F7□/J79 D-F7□V D-J79C D-F7□W/J79W D-F7□WV D-F7BA/F7BAV D-F79F/F7NT	BQ-1		BQ-2
D-P4DW	—		BQP1-050

Note 2) When shipping cylinders, auto switch mounting brackets and auto switches are shipped together.

However, when the D-P4DW type with ø40 to ø100 is mounted, the auto switch is assembled at the time of shipment.

Note 3) Refer to pages 1658 to 1660 for further information on auto switch mounting method.

[Stainless Steel Mounting Screw Kit]

The following stainless steel mounting screw kit (with nuts) is available. Use it in accordance with the operating environment. (Since auto switch spacer (for BQ-2) is not included, order BQ-2 separately.)

BBA2: For D-A7/A8/F7/J7 types

The above stainless steel screws are used when a cylinder is shipped with the D-F7BA/F7BAV auto switches.

When only an auto switch is shipped independently, BBA2 is attached.

Note 4) Refer to page 1659 for details of BBA2.

Note 5) When the D-M9□(A)V type is mounted, order auto switch mounting brackets BQ2-012S, BQ-2 or the stainless steel mounting screw kit BBA2 separately.

Auto Switch Mounting Bracket/Weight

Mounting bracket part no.	Applicable bore size	Weight (g)
BQ-1	ø12 to ø25	1.5
BQ-2	ø32 to ø100	1.5
BQ2-012	ø12 to ø25	5
BQP1-050	ø40 to ø100	16

CUJ

CU

CQS

CQZ-Z

RQ

CQM

CQU

MU-Z

D-□

-X□

Technical data

4 Auto Switch Mounting Brackets/Part No.

Applicable Cylinder Series: CDBQ2 (With end lock)

Auto switch mounting surface	Bore size (mm)		
	ø20, ø25	ø32, ø40, ø50	ø63, ø80, ø100
Auto switch model	Auto switch mounting surface	Auto switch mounting surface	Auto switch mounting surface
	Port/A/B/C side	Port side	A/B/C side
D-A9□ D-A9□V D-M9□ D-M9□V D-M9□W D-M9□WV D-M9□A D-M9□AV	Auto switch mounting brackets are not required.	Auto switch mounting brackets are not required.	① BQ-2 ② BQ2-012 Two kinds of auto switch brackets are used as a set. Auto switch mounting brackets are not required.

Note 1) When a compact auto switch is mounted on the three sides (A, B and C above) other than the port side of ø32 to ø50 cylinders, auto switch mounting brackets shown above are required. Order them separately from cylinders. (The above is also applicable when a compact auto switch is mounted using an auto switch mounting rail, but not using a compact auto switch installation groove for ø63 to ø100 cylinders.)

Ordering example
 CDBQ2B32-50D-M9BW.....1 pc.
 BQ-2.....2 pcs.
 BQ2-012.....2 pcs.

Note 2) When shipping cylinders, auto switch mounting brackets and auto switches are shipped together.

Auto switch model	Bore size (mm)					
	32	40	50	63	80	100
D-A7□/A80 D-A73C/A80C D-A7□H/A80H D-A79W D-F7□/J79 D-F7□V D-J79C D-F7□W/J79W D-F7□WV D-F7BA/F7BAV D-F79F/F7NT				BQ-2		
D-P4DW	—			BQP1-050		

Note 3) When shipping cylinders, auto switch mounting brackets and auto switches are shipped together.

Note 4) Refer to pages 1658 to 1660 for further information on auto switch mounting method.

[Stainless Steel Mounting Screw Kit]

The following stainless steel mounting screw kit (with nuts) is available. Use it in accordance with the operating environment. (Since auto switch spacer (for BQ-2) is not included, order BQ-2 separately.)

BBA2: For D-A7/A8/F7/J7 types

The above stainless steel mounting screws are used when a cylinder is shipped with the D-F7BA/F7BAV auto switches.

When only an auto switch is shipped independently, BBA2 is attached.

Note 5) Refer to page 1659 for details of BBA2.

Note 6) When the D-M9□A(V) type is mounted on a port side other than ø32, ø40 or ø50, order auto switch mounting brackets BQ2-012S, BQ-2 or the stainless steel mounting screw kit BBA2 separately.

Auto Switch Mounting Bracket/Weight

Mounting bracket part no.	Weight (g)
BQ-2	1.5
BQ2-012	5
BQP1-050	16

CUJ

CU

CQS

CQ2-Z

RQ

CQM

CQU

MU-Z





D-□

-X□

Technical data

4 Auto Switch Mounting Brackets/Part No.

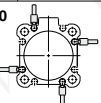
Applicable Cylinder Series: CDQ2, CDQ2W, CDQ2□□□-□S/□T (Single acting), CDQ2, CDQ2W (Large bore size), CDQ2K, CDQ2KW (Non-rotating rod), CDQ2 (Long stroke), CDQ2□S (Anti-lateral load), CDQ2□R/□V (Water resistant)

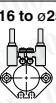
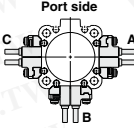
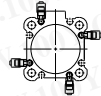
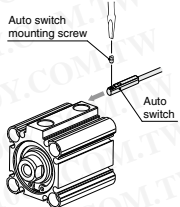
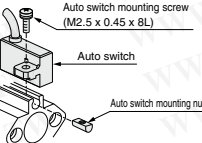
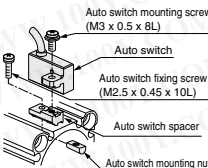
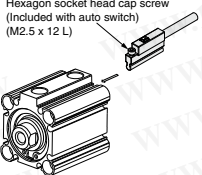
Applicable auto switch	D-M9□/M9□V D-M9□W/M9□WV D-M9□A/M9□AV D-A9□/A9□V	D-F7□/F7□V/J79□/F7□W/J79W/F7□VW D-F7BA/F7BAV/F79F/F7NT D-A7□/A80/A7□H/A80H/A73C/A80C/A79W	D-P3DWA									
Bore size (mm)	φ12 to φ200	φ12 to φ25	φ32 to φ160	φ32 to φ100								
Auto switch mounting bracket part no.	—	BQ4-012	BQ5-032	—								
Auto switch mounting bracket fitting parts lineup/Weight	—	<ul style="list-style-type: none"> Auto switch mounting screw (M2.5 x 8L) Auto switch mounting nut Weight: 1.5 g 	<ul style="list-style-type: none"> Auto switch fixing screw (M2.5 x 10L) Auto switch mounting screw (M3 x 8L) Auto switch spacer Auto switch mounting nut Weight: 3.5 g 	—								
When requesting the enclosure of the auto switch mounting brackets (2 pcs.) with the cylinder for shipment, add "BQ" to the end of the cylinder model number. Standard model no. +BQ Example) CDQ2B32-30DZ-BQ/ CDQ2B32-30DZ-BQ-XC4 (Made to Order)												
Auto switch mounting surface	Surfaces with auto switch mounting slot φ12  φ16 to φ25  φ32 to φ200 	Auto switch mounting rail side only φ12  φ16 to φ25 	A/B/C side except port side 	Surfaces with auto switch mounting slot 								
Mounting of auto switch	 <p>• When tightening the auto switch mounting screw, use a watchmakers' screwdriver with a handle 5 to 6 mm in diameter.</p> <p>Tightening torque for auto switch mounting screw (N·m)</p> <table border="1"> <thead> <tr> <th>Auto switch model</th> <th>Tightening torque</th> </tr> </thead> <tbody> <tr> <td>D-M9□(V)</td> <td rowspan="2">0.05 to 0.15</td> </tr> <tr> <td>D-M9□W(V)</td> </tr> <tr> <td>D-M9□A(V)</td> <td rowspan="2">0.10 to 0.20</td> </tr> <tr> <td>D-A9□(V)</td> </tr> </tbody> </table>	Auto switch model	Tightening torque	D-M9□(V)	0.05 to 0.15	D-M9□W(V)	D-M9□A(V)	0.10 to 0.20	D-A9□(V)	<ol style="list-style-type: none"> Insert the nut into the auto switch mounting slot on the cylinder tube, and place it in the roughly estimated setting position. Engage the ridge on the auto switch mounting nut through the mounting hole on the auto switch mounting arm. Gently screw the auto switch mounting screw into the thread of the auto switch mounting nut through the mounting hole on the auto switch mounting arm. Confirm where the mounting position is, and tighten the auto switch mounting screw to fix the auto switch. The tightening torque of the M2.5 screw must be 0.25 to 0.35 N·m. The detection position can be changed under the conditions in step ③. 	<ol style="list-style-type: none"> Insert the nut into the auto switch mounting slot on the cylinder tube, and place it in the roughly estimated setting position. With the lower tapered part of the auto switch spacer facing the outside of the cylinder tube, line up the M2.5 through hole with the M2.5 female thread of the auto switch mounting nut. Gently screw the auto switch mounting nut fixing screw (M2.5) into the thread of the auto switch mounting nut through the mounting hole. Engage the ridge on the auto switch mounting arm with the recess in the auto switch spacer. Tighten the auto switch mounting screw (M3) to fix the auto switch. The tightening torque of the M3 screw must be 0.35 to 0.45 N·m. Confirm where the mounting position is, and tighten the auto switch fixing screw (M2.5) to fix the auto switch mounting nut. The tightening torque of the M2.5 screw must be 0.25 to 0.35 N·m. The detection position can be changed under the conditions in step ⑤. 	<ol style="list-style-type: none"> Insert the mounting bracket into the mating groove of the cylinder tube. Check the detecting position of the auto switch and fix the auto switch firmly with the hexagon socket head cap screw (M2.5 x 12 L).* If the detecting position is changed, go back to step ①. <p>Note 1) Ensure that the auto switch is covered with the mating groove to protect the auto switch.</p> <p>Note 2) The tightening torque for the hexagon socket head cap screw (M2.5 x 12 L) is 0.2 to 0.3 N·m.</p> 
Auto switch model	Tightening torque											
D-M9□(V)	0.05 to 0.15											
D-M9□W(V)												
D-M9□A(V)	0.10 to 0.20											
D-A9□(V)												

Note) Auto switch mounting bracket and auto switch are enclosed with the cylinder for shipment. For an environment that needs the water resistant auto switch, select the D-M9□A(V) type.
 * The auto switches applicable to the CDQ2□R/□V (water resistant) is the D-M9□A(V) type.
 * The applicable auto switches for the CDQ2□□□-□S/□T (single acting) are those except for the D-P3DW type.

CUJ
CU
CQS
CDQ2-Z
RQ
CQM
CQU
MU-Z

D-□
-X□
Technical data

Auto Switch Mounting Brackets/Part No.

Applicable Cylinder Series: CDQ2

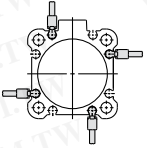
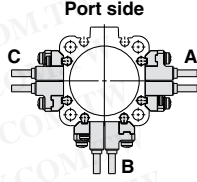
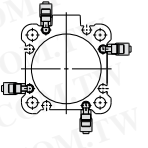
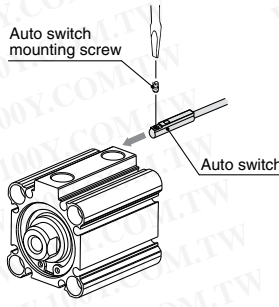
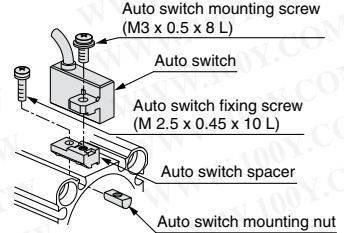
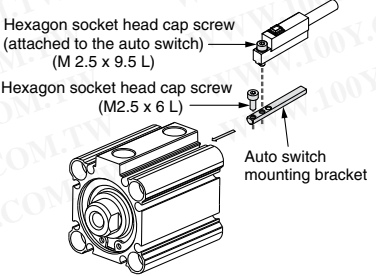
Applicable auto switch	D-M9□/M9□V D-M9□W/M9□WV D-M9□A/M9□AV D-A9□/A9□V	D-F7□/F7□V/J79/J79C/F7□W J79W/F7□WV/D-F7BA/F7BAV F79F/F7NT/D-A7□/A80/A7□H A80H/A73C/A80C/A79W	D-P3DW										
Bore size (mm)	ø32 to ø100												
Auto switch mounting bracket part no.		BQ5-032	BQ6-032S										
Auto switch mounting bracket fitting parts lineup/Weight		<ul style="list-style-type: none"> Auto switch fixing screw (M2.5 x 10 L) Auto switch mounting screw (M3 x 8 L) Auto switch spacer Auto switch mounting nut Weight: 3.5 g	<ul style="list-style-type: none"> Hexagon socket head cap screw (M 2.5 x 6 L) Auto switch mounting bracket (nut) Weight: 5 g										
Auto switch mounting surface	Surfaces with auto switch mounting slot 	A/B/C side except port side Port side 	Surfaces with auto switch mounting slot 										
Mounting of auto switch	 <p>• When tightening the auto switch mounting screw, use a watchmakers' screwdriver with a handle 5 to 6 mm in diameter.</p> <p>Tightening torque for auto switch mounting screw lbf-ft (N-m)</p> <table border="1"> <thead> <tr> <th>Auto switch model</th> <th>Tightening torque</th> </tr> </thead> <tbody> <tr> <td>D-M9□(V)</td> <td>0.04 to 0.11 (0.05 to 0.15)</td> </tr> <tr> <td>D-M9□W(V)</td> <td>0.04 to 0.11 (0.05 to 0.15)</td> </tr> <tr> <td>D-M9□A(V)</td> <td>0.04 to 0.11 (0.05 to 0.15)</td> </tr> <tr> <td>D-A9□(V)</td> <td>0.07 to 0.15 (0.10 to 0.20)</td> </tr> </tbody> </table>	Auto switch model	Tightening torque	D-M9□(V)	0.04 to 0.11 (0.05 to 0.15)	D-M9□W(V)	0.04 to 0.11 (0.05 to 0.15)	D-M9□A(V)	0.04 to 0.11 (0.05 to 0.15)	D-A9□(V)	0.07 to 0.15 (0.10 to 0.20)	<ol style="list-style-type: none"> Insert the nut into the auto switch mounting slot on the cylinder tube, and place it in the roughly estimated setting position. With the lower tapered part of the auto switch spacer facing the outside of the cylinder tube, line up the M2.5 through hole with the M2.5 female thread of the auto switch mounting nut. Gently screw the auto switch mounting nut fixing screw (M2.5) into the thread of the auto switch mounting nut through the mounting hole. Engage the ridge on the auto switch mounting arm with the recess in the auto switch spacer. Tighten the auto switch mounting screw (M3) to fix the auto switch. The tightening torque of the M3 screw must be 0.26 to 0.33 lbf-ft (0.35 to 0.45 N-m). Confirm where the mounting position is, and tighten the auto switch fixing screw (M2.5) to fix the auto switch mounting nut. The tightening torque of the M2.5 screw must be 0.18 to 0.26 lbf-ft (0.25 to 0.35 N-m). The detection position can be changed under the conditions in step ⑤. 	<ol style="list-style-type: none"> Fix the auto switch and the auto switch mounting bracket temporarily by tightening the hexagon socket head cap screw (M2.5 x 9.5 L) attached to the auto switch 1 to 2 turns. Insert the temporarily tightened mounting bracket into the mating groove of the cylinder tube, and slide the auto switch onto the cylinder tube through the groove. To insert the auto switch onto the cylinder/actuator through the groove, first hold the back of the auto switch (lead wire side) and the back of the auto switch mounting bracket together. Check the detecting position of the auto switch and fix the auto switch firmly with the hexagon socket head cap screw (M2.5 x 6 L, M2.5 x 9.5 L).* If the detecting position is changed, go back to step ②. <p>* The hexagon socket head cap screw (M2.5 x 6 L) is used to fix the mounting bracket and cylinder tube. This enables the replacement of the auto switch without adjusting the auto switch position.</p> <p>Note 1) Ensure that the auto switch is covered with the mating groove to protect the auto switch.</p> <p>Note 2) The tightening torque of the hexagon socket head cap screw (M2.5 x 6 L, M2.5 x 9.5 L) must be 0.15 to 0.22 lbf-ft (0.2 to 0.3 N-m).</p> <p>Note 3) Tighten the hexagon socket head cap screws evenly.</p> 
Auto switch model	Tightening torque												
D-M9□(V)	0.04 to 0.11 (0.05 to 0.15)												
D-M9□W(V)	0.04 to 0.11 (0.05 to 0.15)												
D-M9□A(V)	0.04 to 0.11 (0.05 to 0.15)												
D-A9□(V)	0.07 to 0.15 (0.10 to 0.20)												

Note) Auto switch mounting bracket and auto switch are enclosed with the cylinder for shipment. The auto switch mounting bracket for the D-F7BA(V) type uses the BQ5-032 with the normal specifications (iron screw).

Smooth Cylinders

CJ2Y-Z

CM2Y-Z

CG1Y-Z

MBY-Z

CA2Y-Z

CS2Y

CQS

CQ2Y-Z

CJ2X-Z

CM2X-Z

CQS

CQ2X

CUX

Auto Switch

Made to Order

Auto Switch Mounting

Applicable Cylinder: MGP-Z (Basic type), MGP-AZ (Air cushion)

Applicable auto switches	D-M9□/M9□V D-M9□W/M9□WV D-M9□A/M9□AV D-A9□/A9□V	D-P3DWA						
Bore size [mm]	ø12 to ø100	ø25 to ø100						
Auto switch tightening torque	[N·m] <table border="1"> <thead> <tr> <th>Auto switch model</th> <th>Tightening torque</th> </tr> </thead> <tbody> <tr> <td>D-M9□(V) D-M9□W(V) D-M9□A(V)</td> <td>0.05 to 0.15</td> </tr> <tr> <td>D-A9□(V)</td> <td>0.10 to 0.20</td> </tr> </tbody> </table>	Auto switch model	Tightening torque	D-M9□(V) D-M9□W(V) D-M9□A(V)	0.05 to 0.15	D-A9□(V)	0.10 to 0.20	0.2 to 0.3 N·m
Auto switch model	Tightening torque							
D-M9□(V) D-M9□W(V) D-M9□A(V)	0.05 to 0.15							
D-A9□(V)	0.10 to 0.20							

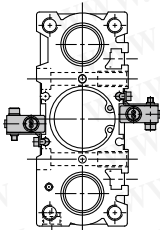
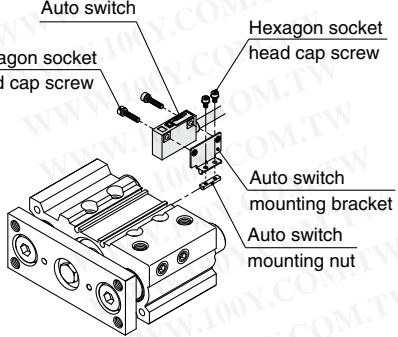
Applicable auto switches	D-P4DW
Bore size [mm]	ø32 to ø100
Auto switch mounting bracket part no.	BMG7-032
Auto switch mounting bracket/ Quantity	<ul style="list-style-type: none"> •Auto switch mounting bracket x 1 pc. •Auto switch mounting nut x 1 pc. •Hexagon socket head cap screw x 2 pcs. •Hexagon socket head cap screw x 2 pcs. (With spring washer x 2 pcs.)
Auto switch mounting surface	
Mounting of auto switch	<ol style="list-style-type: none"> 1. Attach the auto switch to the auto switch mounting bracket with the hexagon socket head cap screw (M3 x 14 L). The tightening torque for the M3 hexagon socket head cap screw is 0.5 to 0.8 N·m. 2. Fix the auto switch mounting nut and the auto switch mounting bracket temporarily by tightening the hexagon socket head cap screw (M2.5 x 5 L). 3. Insert the temporarily fixed auto switch mounting bracket into the auto switch mounting groove, and slide the auto switch through the auto switch mounting groove. 4. Check the detecting position of the auto switch and fix the auto switch firmly with the hexagon socket head cap screw (M2.5 x 5 L). The tightening torque for the M2.5 hexagon socket head cap screw is 0.2 to 0.3 N·m. 5. If the detecting position is changed, go back to step 3. 

Applicable Cylinder: MGP (With end lock), MGPS (Heavy duty guide rod type)

Auto switch model	Bore size [mm]	
	ø25	ø32 to ø100
D-M9□/M9□V D-M9□W/M9□WV D-M9□A/M9□AV D-A9□/A9□V	BMG2-012	
D-P3DWA	BMG2-012	
D-P4DW	—	BMG1-040

*: Cylinders with an end lock are available in ø20 to ø100.
 *: The heavy duty guide rod type is available in ø50 and ø80.

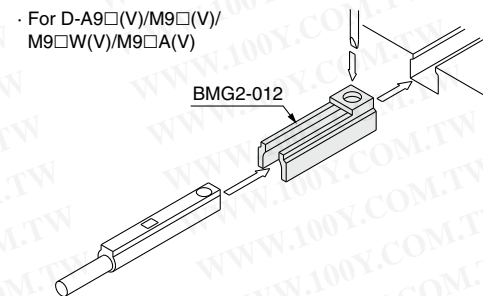

*: Auto switch mounting brackets and auto switches are enclosed with the cylinder for shipment.
 For an environment that needs the water-resistant auto switch, select the D-M9□A(V) type.

Auto Switch Mounting Brackets/Part No.

Auto switch model	Bore size [mm]						
	ø32	ø40	ø50	ø63	ø80	ø100	ø125
D-M9□/M9□V D-M9□W/M9□WV D-M9□A/M9□AV D-A9□/A9□V	BMB5-032	BMB5-032	BA7-040	BA7-040	BA7-063	BA7-063	BA7-080
D-A3□/A44 D-G39/K39	BMB2-032	BMB2-040	BMB1-050	BMB1-063	BMB1-080	BMB1-100	BS1-125
D-F5□/J59 D-F5□W/J59W D-F59F/F5BA D-F5NT D-A5□/A6□/A59W	BT-03	BT-03	BT-05	BT-05	BT-06	BT-06	BT-08
D-P3DWA	—	BA10-040S	BA10-050S	BA10-050S	BA10-063S	BA10-063S	BA10-080S
D-P3DW	BMB9-032S	—	—	—	—	—	—
D-P4DW	BMB3T-040	BMB3T-040	BMB3T-050	BMB3T-050	BMB3T-080	BMB3T-080	BAP2T-080
D-Y59□/Y69□ D-Y7P/Y7PV D-Y7□W/Y7□WV D-Y7BA D-Z7□/Z80	BMB4-032	BMB4-032	BMB4-050	BMB4-050	BA4-063	BA4-063	BA4-080

[Stainless Steel Mounting Screw]

The following stainless steel mounting screw kit (including set screws) is available. Use it in accordance with the operating environment. (Since the auto switch mounting bracket is not included, order it separately.)

BBA1: For D-A5/A6/F5/J5 types

Note 1) Refer to the **WEB catalog** or the Best Pneumatics No. 2 for details on the BBA1.

The above stainless steel screws are used when a cylinder is shipped with the D-F5BA auto switch. When only one auto switch is shipped independently, the BBA1 is attached.

Note 2) When using the D-M9□(V) or Y7BA, do not use the steel set screws which are included with the auto switch mounting brackets above (BMB5-032, BA7-□□□, BMB4-□□□, BA4-□□□). Order a stainless steel screw kit (BBA1) separately, and use the M4 x 6 L stainless steel set screws included in the BBA1.

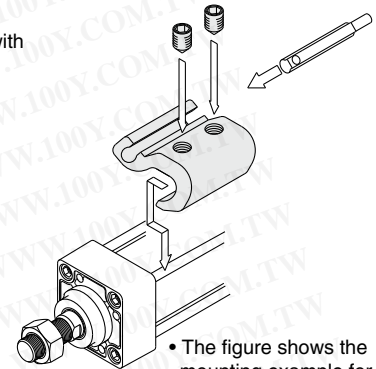

• The figure shows the mounting example for the D-M9□(V)/M9□W(V)/M9□A(V)/A9□(V).

Operating Range

Auto switch model	Bore size [mm]						
	32	40	50	63	80	100	125
D-M9□/M9□V D-M9□W/M9□WV D-M9□A/M9□AV	4	4.5	4.5	4.5	5	6	7
D-Y59□/Y69□ D-Y7P/Y7□V D-Y7□W/Y7□WV D-Y7BA	5.5	5.5	7	7.5	6.5	5.5	7
D-F5□/J59 D-F5□W/J59W D-F5BA/F5NT D-F59F	3.5	4	4	4.5	4.5	4.5	5
D-G39/K39	9	9	9	10	10	11	11
D-P3DWA	—	4.5	4.5	5	5	5.5	6.5
D-P3DW	4.5	—	—	—	—	—	—
D-P4DW	4	4	4	4.5	4	4.5	4.5
D-A9□/A9□V	7	7.5	8.5	9.5	9.5	10.5	12
D-Z7□/Z80	7.5	8.5	7.5	9.5	9.5	10.5	13
D-A5□/A6□	9	9	10	11	11	11	10
D-A59W	13	13	13	14	14	15	17
D-A3□/A44	9	9	10	11	11	11	10

* Values which include hysteresis are for guideline purposes only, they are not a guarantee (assuming approximately ±30% dispersion) and may change substantially depending on the ambient environment.

Standard

Double Acting, Single Rod

MB

Non-rotating Rod

Double Acting, Double Rod

MBW

Non-rotating Rod

Single Rod

MBK

Non-rotating Rod

Double Acting, Double Rod

MBKW

With End Lock

MBB

Low Friction

MB□Q

Auto Switch

Made to Order

Auto Switch Mounting Brackets/Part No.

Auto switch model	Bore size [mm]
	32 to 125
D-M9□/M9□V D-M9□W/M9□WV D-M9□A/M9□AV D-A9□/A9□V	Note) ① BMP1-032 ② BMG2-012
D-Y5□/Y7P D-Y7□W D-Y6□/Y7PV D-Y7□WV D-Y7BA D-Z7□/Z80	① BMP1-032

Note) Two kinds of auto switch mounting brackets are used as a set.

D-M9□(V)/M9□W(V)/M9□A(V)/A9□(V)

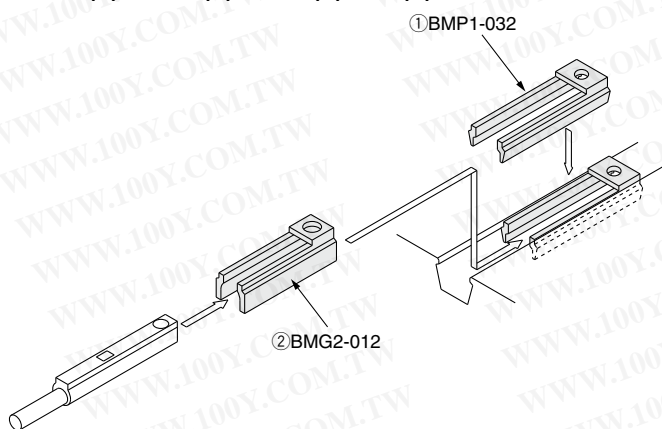

Operating Range

Auto switch model	Bore size [mm]						
	32	40	50	63	80	100	125
D-M9□/M9□V D-M9□W/M9□WV D-M9□A/M9□AV	4	4.5	5	6	6	6	7
D-A9□/A9□V	7	7.5	8	9	9.5	10.5	12.5
D-Y59□/Y69□ D-Y7P/Y7PV D-Y7□W/Y7□WV D-Y7BA	5	4.5	5	5	6.5	7	7
D-Z7□/Z80	10	10	10	11	11	12	14

* Values which include hysteresis are for guideline purposes only, they are not a guarantee (assuming approximately ±30% dispersion) and may change substantially depending on the ambient environment.

Other than the applicable auto switches listed in "How to Order", the following auto switches are mountable.

Refer to the **WEB catalog** or the Best Pneumatics No.2 for the detailed specifications.

Type	Model	Electrical entry	Features
Solid state	D-Y69A, Y69B, Y7PV	Grommet (Perpendicular)	—
	D-Y7NWV, Y7PWV, Y7BWV		Diagnostic indication (2-color indication)
	D-Y59A, Y59B, Y7P	Grommet (In-line)	—
	D-Y7NW, Y7PW, Y7BW		Diagnostic indication (2-color indication)
Reed	D-Y7BA	Grommet (In-line)	Water resistant (2-color indication)
	D-Z73, Z76		—
	D-Z80		Without indicator light

* With pre-wired connector is also available for solid state auto switches. For details, refer to the **WEB catalog** or the Best Pneumatics No. 2.

* Normally closed (NC = b contact) solid state auto switches (D-F9G/F9H/Y7G/Y7H) are also available. For details, refer to the **WEB catalog** or the Best Pneumatics No. 2.

Standard
Double Acting, Single Rod
MB1

Double Acting, Double Rod
MB1W

Non-rotating Rod
Double Acting, Single Rod
MB1K

Auto Switch

Made to Order

Auto Switch Mounting Brackets/Part No.

Auto switch model	Bore size (mm)					
	ø32	ø40	ø50	ø63	ø80	ø100
D-M9□W/M9□WV D-M9□A/M9□AV D-M9□/M9□V D-A9□/A9□V	BMB5-032	BMB5-032	BA7-040	BA7-040	BA7-063	BA7-063
D-A3□/A44 D-G39/K39	BMB2-032	BMB2-040	BMB1-050	BMB1-063	BMB1-080	BMB1-100
D-A5□/A6□/A59W D-F5□/J59 D-F5□W/J59W D-F59F/F5BA D-F5NT	BT-03	BT-03	BT-05	BT-05	BT-06	BT-06
D-P3DWA	—	BA10-040S	BA10-050S	BA10-050S	BA10-063S	BA10-063S
D-P3DW	BMB9-032S	—	—	—	—	—
D-P4DW	BMB3T-040	BMB3T-040	BMB3T-050	BMB3T-050	BMB3T-080	BMB3T-080
D-Z7□/Z80 D-Y59□/Y69□ D-Y7P/Y7PV D-Y7□W/Y7□WV D-Y7BA	BMB4-032	BMB4-032	BMB4-050	BMB4-050	BA4-063	BA4-063

[Stainless Steel Mounting Screw]

The following stainless steel mounting screw kit (including set screws) is available. Use it in accordance with the operating environment. (Since the auto switch mounting bracket is not included, order it separately.)

BBA1: For D-A5/A6/F5/J5 types

Note 1) Refer to the **WEB catalog** or Best Pneumatics No. 3 for details on the BBA1.

The above stainless steel screws are used when a cylinder is shipped with the D-F5BA auto switch. When only the auto switch is shipped independently, the BBA1 is attached.

Note 2) When using the D-M9□A(V) or Y7BA, do not use the steel set screws which are included with the auto switch mounting brackets above (BMB5-032, BA7-□□□, BMB4-□□□, BA4-□□□). Order a stainless steel screw kit (BBA1) separately, and use the M4 x 6 L stainless steel set screws included in the BBA1.

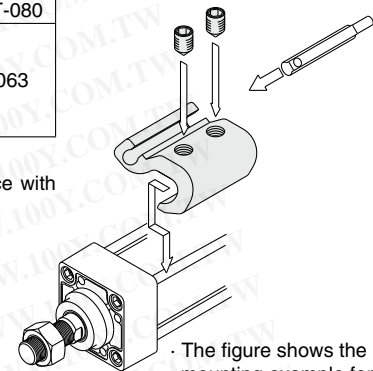

The figure shows the mounting example for the D-A9□(V)/M9□(V)/M9□W(V)/M9□A(V).

Other than the applicable auto switches listed in “How to Order”, the following auto switches are mountable.

Refer to the **WEB catalog** or Best Pneumatics No. 3 for the detailed specifications.

Type	Model	Electrical entry	Features	
Reed	D-A93V/A96V	Grommet (Perpendicular)	—	
	D-A90V		Without indicator light	
	D-B35	Grommet (In-line)	—	
	D-A53/A56/Z73/Z76		Without indicator light	
	D-A67/Z80		Without indicator light	
Solid state	D-M9NV/M9PV/M9BV	Grommet (Perpendicular)	—	
	D-Y69A/Y69B/Y7PV		Diagnostic indication (2-color indication)	
	D-M9NWV/M9PWV/M9BWV			Water resistant (2-color indication)
	D-Y7NWV/Y7PWV/Y7BWV			Magnetic field resistant (2-color indication)
	D-M9NAV/M9PAV/M9BAV		—	
	D-P4DW		—	
	D-F59/F5P/J59	Grommet (In-line)	Diagnostic indication (2-color indication)	
	D-Y59A/Y59B/Y7P			Water resistant (2-color indication)
	D-Y7H			With timer
	D-F59W/F5PW/J59W		Magnetic field resistant (2-color indication)	
	D-Y7NW/Y7PW/Y7BW			
	D-F5BA/Y7BA			
	D-F5NT			
D-P5DW				

* With pre-wired connector is also available for solid state auto switches. For details, refer to the **WEB catalog** or Best Pneumatics No. 3.

* Normally closed (NC = b contact) solid state auto switches (D-F9G/F9H/Y7G/Y7H) are also available. For details, refer to pages the **WEB catalog** or Best Pneumatics No. 3.

Auto Switch Mounting Bracket Part No.

Auto switch model	Bore size (mm)					
	ø32	ø40	ø50	ø63	ø80	ø100
D-M9□/M9□V D-M9□W/M9□WV D-M9□A/M9□AV D-A9□/A9□V	BMB5-032	BMB5-032	BA7-040	BA7-040	BA7-063	BA7-063
D-A3□/A44 D-G39/K39	BMB2-032	BMB2-040	BMB1-050	BMB1-063	BMB1-080	BMB1-100
D-A5□/A6□ D-A59W D-F5□/J59 D-F5□W/J59W D-F5□F D-F5BA D-F5NT	BT-03	BT-03	BT-05	BT-05	BT-06	BT-06
D-P3DWA	—	BA10-040S	BA10-050S	BA10-050S	BA10-063S	BA10-063S
D-P3DW	BMB9-032S	—	—	—	—	—
D-P4DW	BMB3T-040	BMB3T-040	BMB3T-050	BMB3T-050	BMB3T-080	BMB3T-080
D-Z7□/Z80 D-Y59□/Y69□ D-Y7P/Y7PV D-Y7□W D-Y7□WV D-Y7BA	BMB4-032	BMB4-032	BMB4-050	BMB4-050	BA4-063	BA4-063

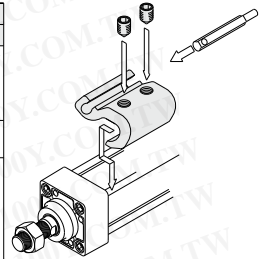

* The above figure shows the mounting example of D-A9□(V)/M9□(V)/M9□W(V)/M9□A(V).

[Mounting screws set made of stainless steel]

The following set of mounting screws made of stainless steel is also available. Use it in accordance with the operating environment. (Please order the auto switch mounting bracket separately, since it is not included.)

BBA1: For D-A5/A6/F5/J5 types

D-F5BA auto switch is set on the cylinder with the stainless steel screws above when shipped. When an auto switch is shipped independently, BBA1 is attached.

Note 1) Refer to page 1997 for the details of BBA1.

Note 2) When using D-M9□A(V)/Y7BA, do not use the steel set screws which is included with the auto switch mounting brackets above (BMB5-032, BA7-□□□, BMB4-□□□, BA4-□□□). Order a stainless steel screw set (BBA1) separately, and select and use the M4 x 6L stainless steel set screws included in the BBA1.

- CLJ2
- CLM2
- CLG1
- CL1
- MLGC
- CNG
- MNB**
- CNA2
- CNS
- CLS
- CLQ
- RLQ
- MLU
- MLGP
- ML1C

Besides the models listed in How to Order, the following auto switches are applicable. For detailed specifications, refer to pages 1893 to 2007.

Auto switch type	Model	Electrical entry (Fetching direction)	Features
Reed	D-A93V, A96V	Grommet (Perpendicular)	—
	D-A90V		Without indicator light
	D-A53, A56, Z73, Z76	Grommet (In-line)	—
	D-A67, Z80		Without indicator light
Solid state	D-M9NV, M9PV, M9BV	Grommet (Perpendicular)	—
	D-Y69A, Y69B, Y7PV		Diagnostic indication (2-color indication)
	D-M9NWV, M9PWV, M9BWW		Water resistant (2-color indication)
	D-Y7NWV, Y7PWV, Y7BWW		—
	D-M9NAV, M9PAV, M9BAV		—
	D-F59, F5P, J59	Grommet (In-line)	—
	D-Y59A, Y59B, Y7P		Diagnostic indication (2-color indication)
	D-F59W, F5PW, J59W		Water resistant (2-color indication)
	D-Y7NW, Y7PW, Y7BW		With timer
	D-F5BA, Y7BA		Magnetic field resistant (2-color indication)
	D-F5NT		—
D-P5DW	—		

* With pre-wired connector is available for solid state auto switches. For details, refer to pages 1960 and 1961.

* Normally closed (NC = b contact), solid state auto switch (D-F9G/F9H/Y7G/Y7H type) are also available. For details, refer to pages 1911 and 1913.

- D-□
- X□

Auto Switch Mounting Brackets/Part No.

<Tie-rod mounting>

Auto switch model	Bore size (mm)				
	40	50	63	80	100
D-M9□/M9□V D-M9□W/M9□WV D-M9□A/M9□AV D-A9□/A9□V	BA7-040	BA7-040	BA7-063	BA7-080	BA7-080
D-F5□/J59 D-F5□W/J59W D-F59F/F5NT D-A5□/A6□ D-A59W	BT-04	BT-04	BT-06	BT-08	BT-08
D-G39C/K39C D-A3□C/A44C	BA3-040	BA3-050	BA3-063	BA3-080	BA3-100
D-Y59□/Y69□ D-Y7P/Y7PV D-Y7□W/Y7□WV D-Y7BA D-Z7□/Z80	BA4-040	BA4-040	BA4-063	BA4-080	BA4-080
D-P3DW	BMB9-050S	BMB9-050S	BA9T-063S	BA9T-080S	BA9T-080S
D-P4DW	BAP2-040	BAP2-040	BAP2-063	BAP2-080	BAP2-080

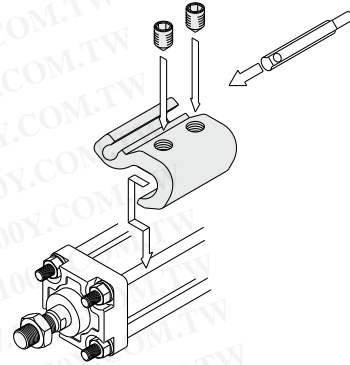

* The figure shows the mounting example for the D-M9□(V)/M9□W(V)/M9□A(V)/A9□(V) types.

<Band mounting>

Except air-hydro type

Auto switch model	Bore size (mm)				
	40	50	63	80	100
D-G39/K39 D-A3□/A44	BDS-04M	BDS-05M	BMB1-063	BMB1-080	BMB1-100
D-G5□/K59 D-G5□W/K59W D-G59F D-G5NT D-G5NB D-B5□/B64 D-B59W	BH2-040	BA5-050	BAF-06	BAF-08	BAF-10

Air-hydro type

Auto switch model	Bore size (mm)				
	40	50	63	80	100
D-G39/K39 D-A3□/A44	BD1-04M	BD1-05M	BD1-06M	BD1-08M	BD1-10M
D-G5□/K59 D-G5□W/K59W D-G59F D-G5NT D-G5NB D-B5□/B64 D-B59W	BA-04	BA-05	BA-06	BA-08	BA-10

Note 1) Auto switch brackets are included in the D-A3□C/A44C/G39C/K39C types. Specify the part number as follows depending on the cylinder size when ordering.
(Example) ø40: D-A3□C-4, ø50: D-A3□C-5, ø63: D-A3□C-6, ø80: D-A3□C-8, ø100: D-A3□C-10

[Stainless Steel Mounting Screw]

The following stainless steel mounting screw kit (including set screws) is also available. Use it in accordance with the operating environment.
(Since the auto switch mounting bracket and band are not included, order them separately.)

BBA1: For D-A5/A6/F5/J5 types
BBA3: For D-B5/B6/G5/K5 types

Note 2) Refer to the **WEB catalog** or the Best Pneumatics No. 2 for details on the BBA1 and BBA3.

The above stainless steel screws are used when a cylinder is shipped with D-F5BA or G5BA auto switches. When only an auto switch is shipped independently, the BBA1 or BBA3 is attached.

Note 3) When using the D-M9□A(V) or Y7BA, do not use the steel set screws which are included with the above auto switch mounting brackets (BA7-□□□, BA4-□□□). Order a stainless steel screw kit (BBA1) separately, and use the M4 x 6 L stainless steel set screws included in the BBA1.

Note 4) There is a difference in the cylinder tube thickness depending on the cylinder model. Use caution when a band mounting type is used as an applicable auto switch and a cylinder model is changed.

Other than the applicable auto switches listed in "How to Order", the following auto switches are mountable.

Refer to the **WEB catalog** or the Best Pneumatics No. 2 for the detailed specifications.

Type	Model	Electrical entry	Features
Solid state	D-M9NV/M9PV/M9BV	Grommet (Perpendicular)	—
	D-Y69A/Y69B/Y7PV		Diagnostic indication (2-color indication)
	D-M9NWV/M9PWV/M9BWW		Water resistant (2-color indication)
	D-Y7NWV/Y7PWV/Y7BWW		—
	D-M9NAV/M9PAV/M9BAV		Diagnostic indication (2-color indication)
	D-Y59A/Y59B/Y7P	Grommet (In-line)	Water resistant (2-color indication)
	D-F59/F5P/J59		With timer
	D-Y7NW/Y7PW/Y7BW		Magnetic field resistant (2-color indication)
	D-F59W/F5PW/J59W		—
	D-F5BA/Y7BA		Without indicator light
D-F5NT/G5NT	Grommet (In-line)	—	
D-P5DW		Without indicator light	
D-A93V/A96V		—	
Reed	D-A90V	Grommet (Perpendicular)	Without indicator light
	D-A53/A56/B53/Z73/Z76	Grommet (In-line)	—
	D-A67/Z80		Without indicator light

* With pre-wired connector is also available for solid state auto switches. For details, refer to the **WEB catalog** or the Best Pneumatics No. 2.

* Normally closed (NC = b contact) solid state auto switches (D-F9G/F9H/Y7G/Y7H) are also available. For details, refer to the **WEB catalog** or the Best Pneumatics No. 2.

Standard	Double Acting, Single Rod	CA2
Non-rotating Rod	Double Acting, Double Rod	CA2W
Non-rotating Rod	Double Acting, Single Rod	CA2K
Non-rotating Rod	Double Acting, Double Rod	CA2KW
With End Lock		CBA2
Air-hydro	Double Acting, Single Rod	CA2H
Air-hydro	Double Acting, Double Rod	CA2WH
Low Friction		CA2Q
		Auto Switch
		Made to Order

Auto Switch Mounting Brackets/Part No.

<Tie-rod mounting>

Auto switch model	Bore size (mm)				
	40	50	63	80	100
D-A9□/A9□V D-M9□/M9□V D-M9□W/M9□WV D-M9□A/M9□AV	BA7-040	BA7-040	BA7-063	BA7-080	BA7-080
D-A5□/A6□ D-A59W D-F5□/J5□ D-F5□W/J59W D-F59F/F5NT	BT-04	BT-04	BT-06	BT-08	BT-08
D-A3□C/A44C D-G39C/K39C	BA3-040	BA3-050	BA3-063	BA3-080	BA3-100
D-Z7□/Z80 D-Y59□/Y69□ D-Y7P/Y7PV D-Y7□W/Y7□WV D-Y7BA	BA4-040	BA4-040	BA4-063	BA4-080	BA4-080
D-P3DW	BMB9-050S	BMB9-050S	BA9T-063S	BA9T-080S	BA9T-080S
D-P4DW	BAP2-040	BAP2-040	BAP2-063	BAP2-080	BAP2-080

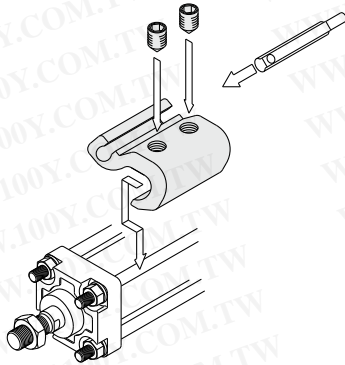

* The figure shows the mounting example for the D-A9□(V)/M9□(V)/M9□W(V)/M9□A(V)L types.

<Band mounting>

Auto switch model	Bore size (mm)				
	40	50	63	80	100
D-A3□/A44 D-G39/K39	BDS-04M	BDS-05M	BMB1-063	BMB1-080	BMB1-100
D-B5□/B64 D-B59W D-G5□/K59 D-G5□W/K59W D-G59F D-G5NT D-G5NB	BH2-040	BA5-050	BAF-06	BAF-08	BAF-10

Note 1) The auto switch mounting bracket is included in the D-A3□C/A44C/G39C/K39C types. Specify the part number as follows depending on the cylinder size when ordering.
(Example) ø40: D-A3□C-4, ø50: D-A3□C-5, ø63: D-A3□C-6, ø80: D-A3□C-8, ø100: D-A3□C-10

[Stainless Steel Mounting Screw]

The following stainless steel mounting screw kit (including set screws) is also available. Use it in accordance with the operating environment.
(Since the auto switch mounting bracket is not included, order it separately.)

BBA1: For D-A5/A6/F5/J5 types
BBA3: For D-B5/B6/G5/K5 types

Note 2) Refer to the **WEB catalog** or Best Pneumatics No. 3 for details on the BBA1 and BBA3.

The above stainless steel screws are used when a cylinder is shipped with D-F5BA or G5BA auto switches. When only an auto switch is shipped independently, the BBA1 or BBA3 is attached.

Note 3) When using the D-M9□A(V) or Y7BA, do not use the steel set screws which are included with the auto switch mounting brackets above (BA7-□□□, BA4-□□□). Order a stainless steel screw kit (BBA1) separately, and use the M4 x 6L stainless steel set screws included in the BBA1.

Note 4) There is a difference in the cylinder tube thickness depending on the cylinder model. When a band mounting type is used as an applicable auto switch and a cylinder model is changed, use caution.

勝特力材料 886-3-5753170
胜特力电子(上海) 86-21-34970699
胜特力电子(深圳) 86-755-83298787
[Http://www.100y.com.tw](http://www.100y.com.tw)

Other than the applicable auto switches listed in "How to Order", the following auto switches are mountable.

Refer to the **WEB catalog** or Best Pneumatics No. 3 for the detailed specifications.

Type	Model	Electrical entry	Features
Reed	D-A93V/A96V	Grommet (Perpendicular)	—
	D-A90V		Without indicator light
	D-A53/A56/B53/Z73/Z76	Grommet (In-line)	—
	D-A67/Z80		Without indicator light
Solid state	D-M9NV/M9PV/M9BV	Grommet (Perpendicular)	—
	D-Y69A/Y69B/Y7PV		Diagnostic indication (2-color indication)
	D-M9NWV/M9PWV/M9BWW		
	D-Y7NWV/Y7PWV/Y7BWW		
	D-M9NAV/M9PAV/M9BAV	Grommet (In-line)	—
	D-Y59A/Y59B/Y7P		Diagnostic indication (2-color indication)
	D-F59/F5P/J59		
	D-Y7NW/Y7PW/Y7BW		With timer
	D-F59W/F5PW/J59W		
	D-F5BA/Y7BA		
	D-F5NT/G5NT		
	D-P5DW		

* With pre-wired connector is also available for solid state auto switches. For details, refer to the **WEB catalog** or Best Pneumatics No. 3.

* Normally closed (NC = b contact) solid state auto switches (D-F9G/F9H/Y7G/Y7H) are also available. For details, refer to the **WEB catalog** or Best Pneumatics No. 3.

* Wide range detection type, solid state auto switch (D-G5NBL) is also available. For details, refer to the **WEB catalog** or Best Pneumatics No. 3.

Smooth Cylinders
CJ2Y-Z
CM2Y-Z
CG1Y-Z
MBY-Z
CA2Y-Z
CS2Y
CSY
CQ2Y-Z
CQ2Y-Z
CJ2X-Z
CM2X-Z
CQ2X
CUX
Auto Switch
Made to Order