

勝特力材料 886-3-5753170  
 勝特力電子(上海) 86-21-34970699  
 勝特力電子(深圳) 86-755-83298787  
[Http://www.100y.com.tw](http://www.100y.com.tw)

REV.	DESCRIPTION	ENG.	APPROVE
更改	說明	修改人	審核

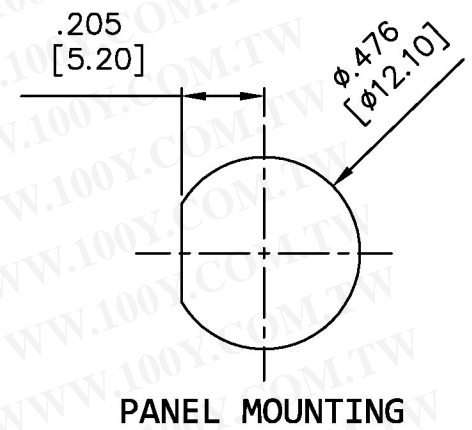
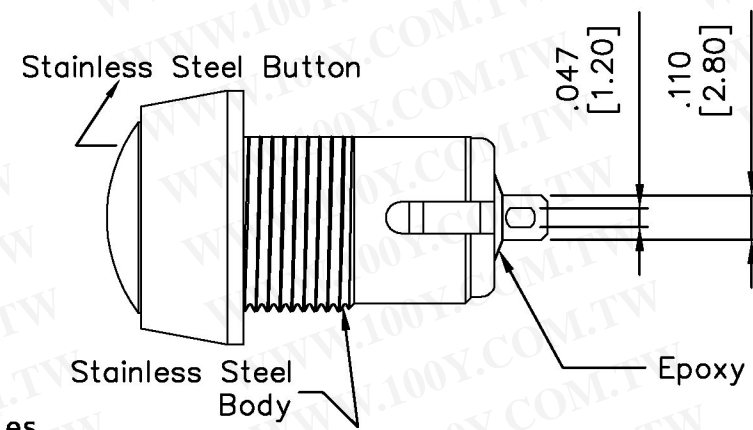
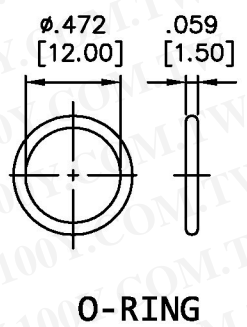
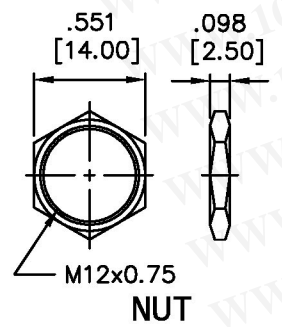
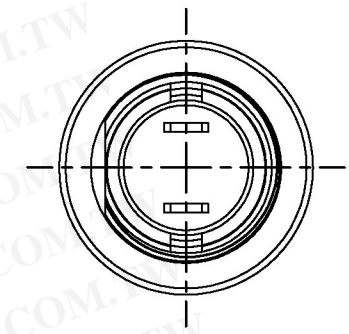
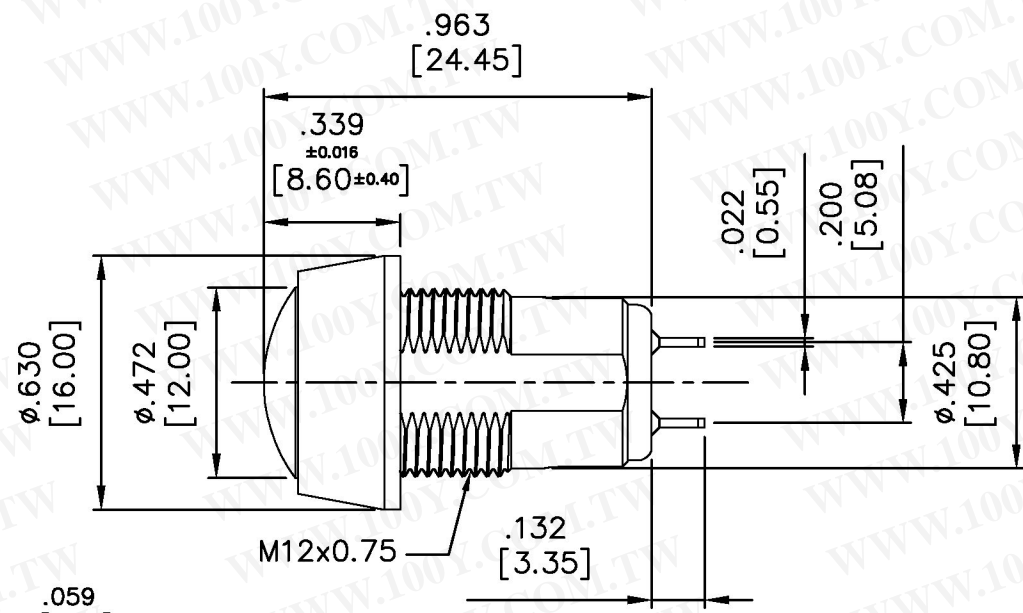
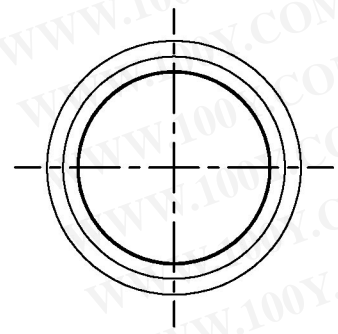

**SPECIFICATION:**

- Rating:  
 100mA 24VDC - life cycles 200,000 cycles  
 2A 125VAC - life cycles 10,000 cycles
- Contact Resistance: 50mΩ max. initial
- Insulation Resistance: 1GΩ min. at 500VDC
- Dielectric Strength: 1000 VAC for 1 minute
- Operating Temperature: -30°C to +85°C
- Total Travel: 2.5mm
- Operating Force: 2N~5N
- Contact Bounce: 10ms
- Mechanical Life: 1,000,000 cycles
- Soldering: 350°C max. for 5 seconds.

ITEM NO. 料號	AV04-B42-M1
----------------	-------------

UNLESS OTHERWISE SPECIFIED DIMENSIONS ARE IN MILLIMETERS ANGULAR TOLERANCE: ±1.0°		USED 用途 AV	APPD. 審核 Amy 2011/12/15
DIMENSIONS TOLERANCE		FINISH 處理	CHKD. 校對 Amy 2011/12/15
0.00 TO 10.00mm	±0.20mm	SCALE 比例 2 / 1	DR. 製圖 Kyme 2011/12/15
10.01 TO 20.00mm	±0.25mm	UNIT 單位 in(mm)	
20.01 TO 30.00mm	±0.30mm		
30.01	±0.40mm	TITLE 名稱 PUSHBUTTON SWITCH	
MATERIAL		DWG NO. 圖號 AV04-B42-M1	SIZE 圖紙 A4
		FILE NAME 檔案名稱 AV04-B42-M1.DWG	SHEET 張 1 / 1
			REV. 更改 1