

Universal Operational Amplifier Single, Dual, Quad (PDIP) Evaluation Module With Shutdown

User's Guide

IMPORTANT NOTICE

Texas Instruments and its subsidiaries (TI) reserve the right to make changes to their products or to discontinue any product or service without notice, and advise customers to obtain the latest version of relevant information to verify, before placing orders, that information being relied on is current and complete. All products are sold subject to the terms and conditions of sale supplied at the time of order acknowledgment, including those pertaining to warranty, patent infringement, and limitation of liability.

TI warrants performance of its products to the specifications applicable at the time of sale in accordance with TI's standard warranty. Testing and other quality control techniques are utilized to the extent TI deems necessary to support this warranty. Specific testing of all parameters of each device is not necessarily performed, except those mandated by government requirements.

Customers are responsible for their applications using TI components.

In order to minimize risks associated with the customer's applications, adequate design and operating safeguards must be provided by the customer to minimize inherent or procedural hazards.

TI assumes no liability for applications assistance or customer product design. TI does not warrant or represent that any license, either express or implied, is granted under any patent right, copyright, mask work right, or other intellectual property right of TI covering or relating to any combination, machine, or process in which such products or services might be or are used. TI's publication of information regarding any third party's products or services does not constitute TI's approval, license, warranty or endorsement thereof.

Reproduction of information in TI data books or data sheets is permissible only if reproduction is without alteration and is accompanied by all associated warranties, conditions, limitations and notices. Representation or reproduction of this information with alteration voids all warranties provided for an associated TI product or service, is an unfair and deceptive business practice, and TI is not responsible nor liable for any such use.

Resale of TI's products or services with statements different from or beyond the parameters stated by TI for that product or service voids all express and any implied warranties for the associated TI product or service, is an unfair and deceptive business practice, and TI is not responsible nor liable for any such use.

Also see: [Standard Terms and Conditions of Sale for Semiconductor Products](http://www.ti.com/sc/docs/stdterms.htm). www.ti.com/sc/docs/stdterms.htm

Mailing Address:

Texas Instruments
Post Office Box 655303
Dallas, Texas 75265

Preface

Related Documentation From Texas Instruments

- ***Amplifiers and Comparators Data Book*** (literature number SLOD002). This data book contains data sheets and other information on the TI operational amplifiers that can be used with this evaluation module.
- ***Power Supply Circuits Data Book*** (literature number SLVD002). This data book contains data sheets and other information on the TI shunt regulators that can be used with this evaluation module.

FCC Warning

This equipment is intended for use in a laboratory test environment only. It generates, uses, and can radiate radio frequency energy and has not been tested for compliance with the limits of computing devices pursuant to subpart J of part 15 of FCC rules, which are designed to provide reasonable protection against radio frequency interference. Operation of this equipment in other environments may cause interference with radio communications, in which case the user at his own expense will be required to take whatever measures may be required to correct this interference.

Trademarks

PowerPAD is a trademark of Texas Instruments.



Contents

1	Introduction	1-1
1.1	Design Features	1-2
1.2	Power Requirements	1-2
2	Evaluation Module Layout	2-1
2.1	Physical Considerations	2-2
2.2	Area 100–Single Device PDIP	2-3
2.3	Area 200–Dual Device PDIP	2-4
2.4	Area 300–Quad Device PDIP	2-5
2.5	General Power Dissipation Considerations	2-7
2.6	EVM Component Placement	2-8
2.7	EVM Board Layout	2-9
3	Example Circuits	3-1
3.1	Schematic Conventions	3-2
3.2	Inverting Amplifier	3-2
3.3	Noninverting Amplifier	3-3
3.4	Differential Amplifier	3-4
3.5	Sallen-Key Low-Pass Filter	3-5
3.6	Sallen-Key High-Pass Filter	3-6
3.7	Two Operational Amplifier Instrumentation Amplifier	3-8
3.8	Quad Operational Amplifier Instrumentation Amplifier	3-10

Figures

2-1	Area 100 Schematic—Single Device, PDIP (8-pin)	2-3
2-2	Area 200 Schematic—Dual Device, PDIP (10-pin)	2-4
2-3	Area 300 Schematic—Quad Device, PDIP (16-pin)	2-6
2-4	Maximum Power Dissipation vs Free-Air Temperature	2-7
2-5	EVM Component Placement	2-8
2-6	EVM Board Layout—Top	2-9
2-7	EVM Board Layout—Bottom	2-10
3-1	Inverting Amplifier With Dual Supply Using Area 100	3-2
3-2	Noninverting Amplifier With Single Supply Using Area 100	3-3
3-3	Single Operational Amplifier Differential Amplifier With Single Supply Using Area 100 ..	3-4
3-4	Sallen-Key Low-Pass Filter With Dual Supply Using Area 200	3-5
3-5	Sallen-Key High-Pass Filter With Single Supply Using Area 200	3-7
3-6	Two Operational Amplifier Instrumentation Amplifier With Single Supply Using Area 200	3-9
3-7	Quad Operational Amplifier Instrumentation Amplifier With Dual Supply Using Area 300	3-11

Table

2-1	Dissipation Rating Table	2-7
-----	--------------------------------	-----

Introduction

This user's guide describes the universal operational amplifier single, dual, quad (PDIP) evaluation module (EVM) with shutdown (SLOP249). The EVM simplifies evaluation of Texas Instruments surface-mount op amps with or without shutdown feature.

Topic	Page
1.1 Design Features	1-2
1.2 Power Requirements	1-2

1.1 Design Features

The EVM board design allows many circuits to be constructed easily and quickly. There are three circuit development areas on the board, and each uses IC amplifiers in the PDIP package. Area 100 is for a single operational amplifier (op amp), with or without shutdown. It also features offset nulling pin pads. Area 200 is for a dual op amp, with or without shutdown. Area 300 is for a quad op amp, with or without shutdown. A few possible circuits include:

- Voltage follower
- Noninverting amplifier
- Inverting amplifier
- Simple or algebraic summing amplifier
- Difference amplifier
- Current to voltage converter
- Voltage to current converter
- Integrator/low-pass filter
- Differentiator/high-pass filter
- Instrumentation amplifier
- Sallen-Key filter

The EVM PCB is of two-layer construction, with a ground plane on the solder side. Circuit performance should be comparable to final production designs.

1.2 Power Requirements

The devices and designs that are used dictate the input power requirements. Three input terminals are provided for each area of the board:

Vx+	Positive input power for area x00	i.e., V1+ ⇒ area 100
GNDx	Ground reference for area x00	i.e., GND2 ⇒ area 200
Vx-	Negative input power for area x00	i.e., V3- ⇒ area 300

Each area has four bypass capacitors – two for the positive supply, and two for the negative supply. Each supply should have a 1- μ F to 10- μ F capacitor for low-frequency bypassing and a 0.01- μ F to 0.1- μ F capacitor for high-frequency bypassing.

When using single-supply circuits, the negative supply is shorted to ground by bridging C104 or C105 in area 100, C209 or C210 in area 200, or C311 or C312 in area 300. Power input is between Vx+ and GNDx. The voltage reference circuitry is provided for single-supply applications that require a reference voltage to be generated.

Evaluation Module Layout

This chapter shows the universal operational amplifier single, dual, quad (PDIP) evaluation module (EVM) with shutdown board layout, schematics of each area, and describes the relationships between the three areas.

Topic	Page
2.1 Physical Considerations	2-2
2.2 Area 100—Single Device PDIP	2-3
2.3 Area 200—Dual Device PDIP	2-4
2.4 Area 300—Quad Device PDIP	2-5
2.5 General Power Dissipation Considerations	2-7
2.6 EVM Component Placement	2-8
2.7 EVM Board Layout	2-9

2.1 Physical Considerations

The EVM board has three circuit development areas. Each area can be separated from the others by breaking along the score lines. The circuit layout in each area supports an op amp package, voltage reference, and ancillary devices. The op amp package is unique to each area as described in the following paragraphs. The voltage reference and supporting devices are the same for all areas. Surface-mount or through-hole components can be used for all capacitors and resistors on the board.

The voltage reference can be either surface-mount or through-hole. If surface mount is desired, the TLV431ACDBV5 or TLV431AIDBV5 adjustable shunt regulators can be used. If through hole is desired, the TLV431ACLP, TLV431AILP, TL431CLP, TL431ILP, or TL431AILP adjustable shunt regulators can be used. Refer to Texas Instruments' *Power Supply Circuits Data Book* (literature number SLVD002) for details on usage of these shunt regulators.

Each passive component (resistor or capacitor) has a surface-mount 1206 footprint with through holes at 0.2" spacing on the outside of the 1206 pads. C105, C106, C107, C207, C208, C209, C312, C314, and C315 have a surface mount 1210 footprint with through holes at 0.2" spacing on the outside of the 1210 pads. Therefore, either surface-mount or through-hole parts can be used. The potentiometer for the offset nulling feature in area 100 can also be either a surface-mount or a through-hole unit.

Figures 2–1 through 2–3 show schematics for each of the board areas. The schematics show all components that the board layout can accommodate. These should only be used as reference, since not all components will be used at any one time.

2.2 Area 100—Single Device PDIP

Area 100 uses 1xx reference designators, and is compatible with a single op amp, with or without shutdown, packaged as an 8-pin PDIP. This surface-mount package is designated by a P suffix in TI part numbers, as in TxxxxCP etc.

Offset nulling can be extremely important in some applications. The EVM accommodates TI IC op amps that provide this feature. The input offset can be adjusted by connecting a 100-k Ω potentiometer between terminals 1 and 5 of the device and connecting the wiper to VCC- via a resistor (R101) as shown below. This resistor is used to fine tune the offset adjustment. For example, when using the TLC070 or TLC071 device and a 100-k Ω nulling potentiometer, the offset voltage adjustment is ± 10 mV when R101 is 5.6 k Ω and ± 3 mV when R101 is 20 k Ω .

When using the nonshutdown version of the device, pin 8 of the IC is a no connect.

Figure 2–1 shows the area 100 schematic.

Figure 2–1. Area 100 Schematic—Single Device, PDIP (8 pin)

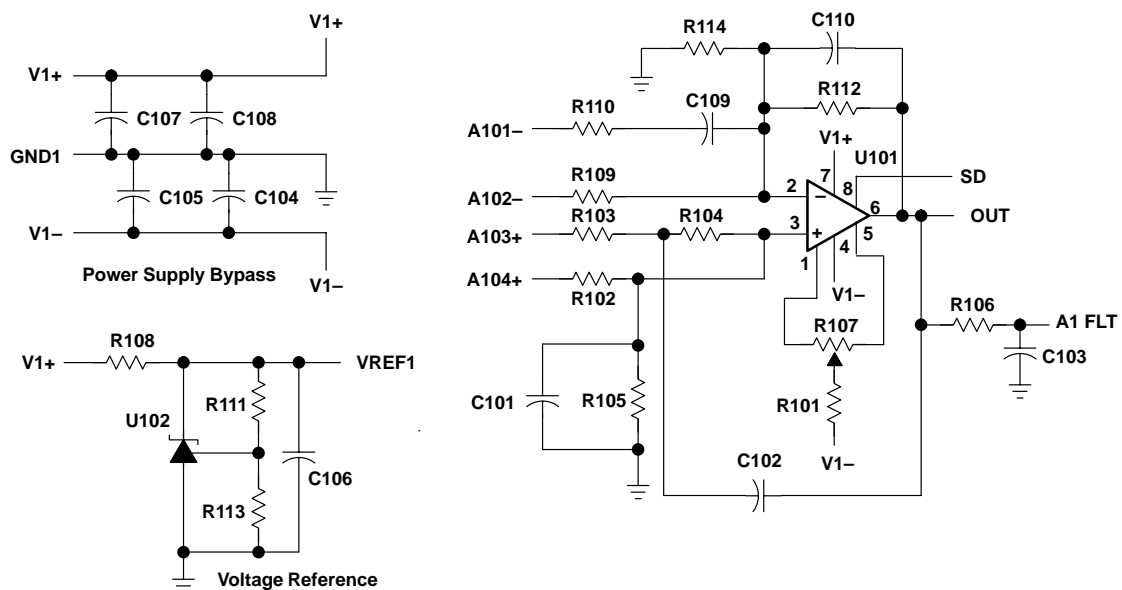

2.3 Area 200—Dual Device PDIP

Area 200 uses 2xx reference designators, and is compatible with dual op amps, with or without shutdown, packaged as an 8-pin (without shutdown) or 14-pin (with shutdown) PDIP. This package is designated by a P suffix (8-pin) or an N suffix (14-pin) in TI part numbers, as in TxxxxCP and TxxxxCN.

When using the nonshutdown version of the device, ensure that the IC is aligned at the top of the IC hole array—the last six PCB holes (three on each side—pins 5, 6, 7, 8, 9, and 10) will not be used.

Figure 2–2 shows the area 200 schematic.

Figure 2–2. Area 200 Schematic—Dual Device, PDIP (14 pin)

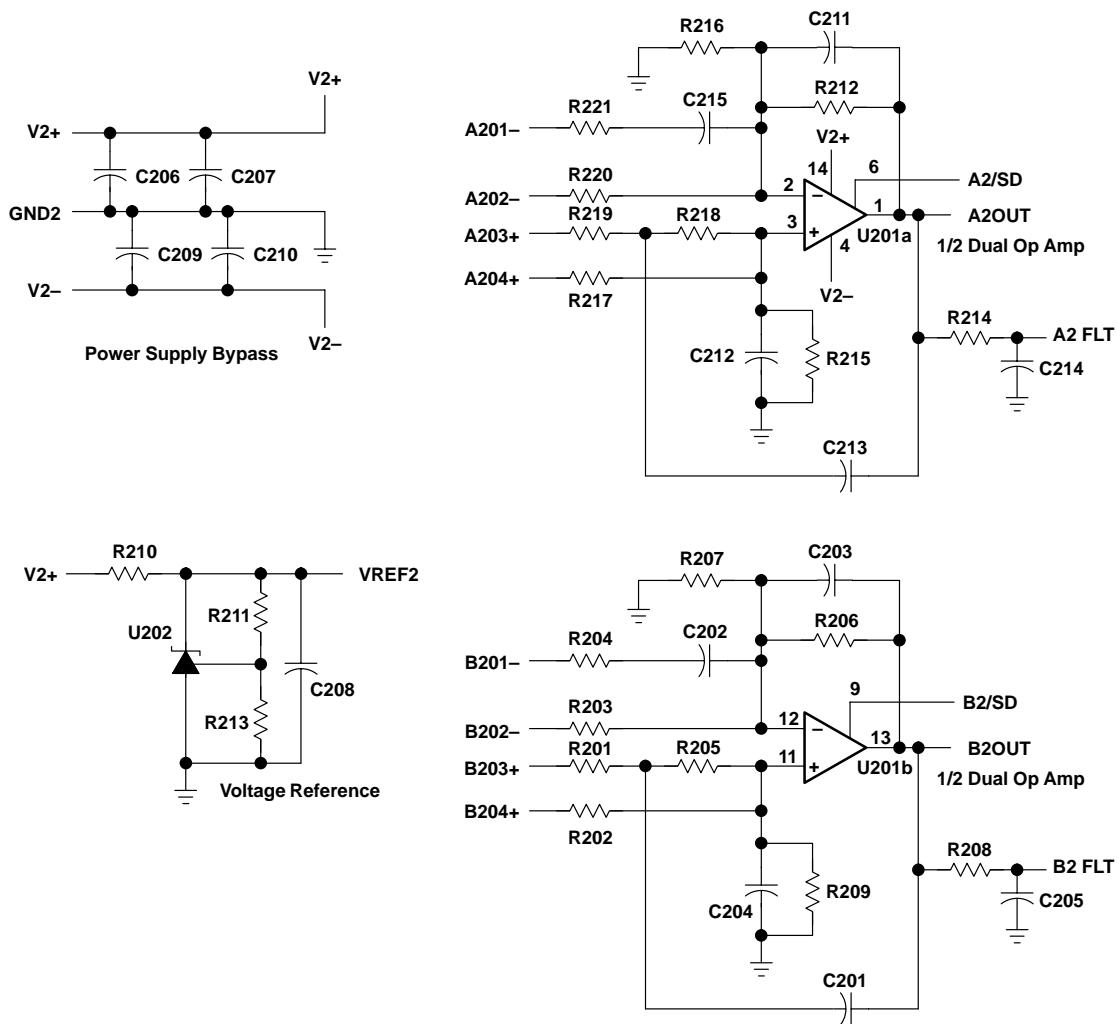

2.4 Area 300—Quad Device PDIP

Area 300 uses 3xx reference designators, and is compatible with quad op amps, with or without shutdown, packaged in a 14-pin (without shutdown) or 16-pin (with shutdown) PDIP. This surface-mount package is designated by a N suffix in TI part numbers, as in TxxxxIN.

When using the nonshutdown version of the device, ensure that the IC is aligned at the top of the IC hole array—the last two PCB holes (one on each side—pins 8 and 9) will not be used.

Figure 2–3 shows the area 300 schematic.

Figure 2–3. Area 300 Schematic—Quad Device PDIP (16 pin)

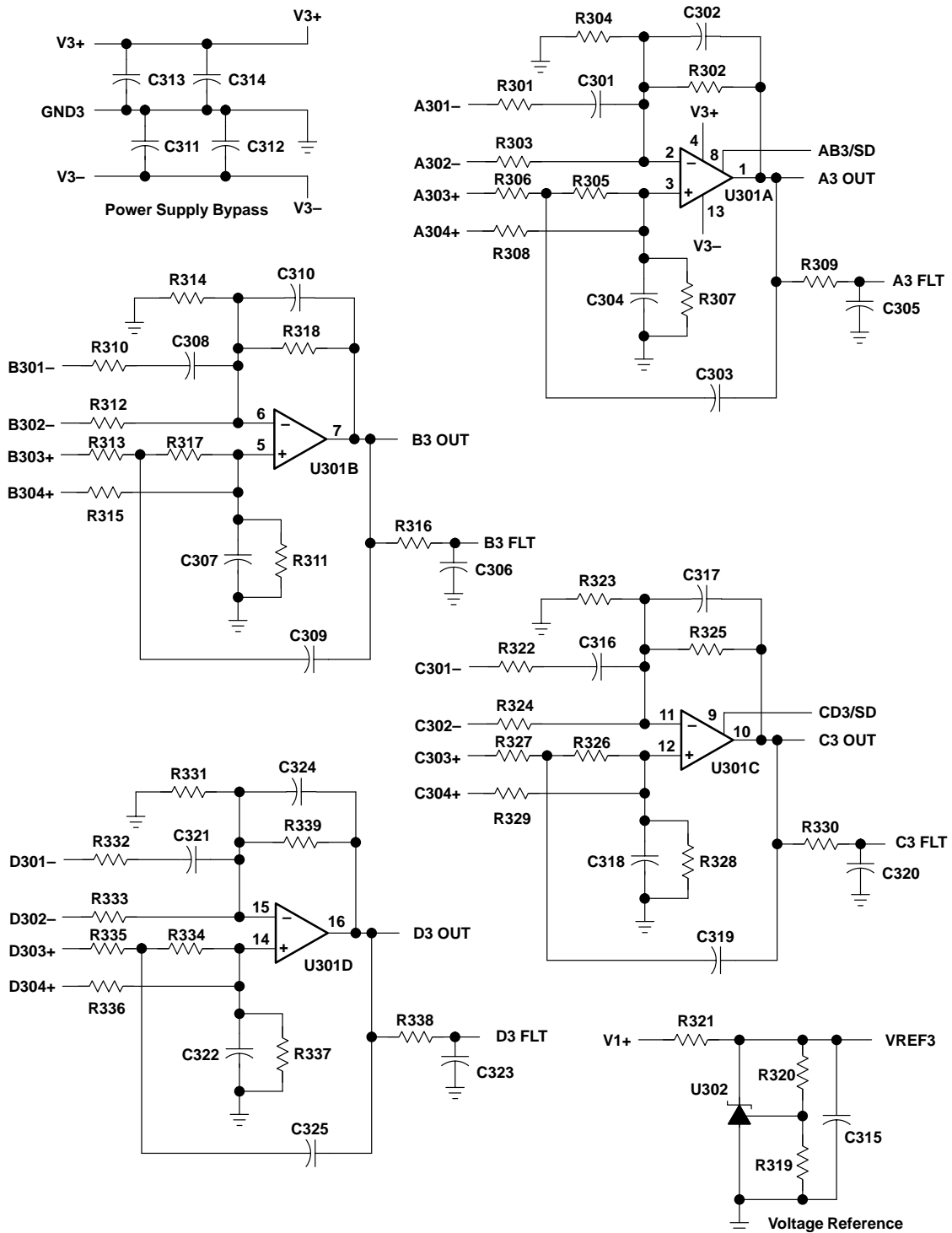

2.5 General Power Dissipation Considerations

For a given θ_{JA} , the maximum power dissipation is shown in Figure 2–4 and is calculated by the following formula:

$$P_D = \left(\frac{T_{MAX} - T_A}{\theta_{JA}} \right)$$

Where:

- P_D = Maximum power dissipation of Txxxx IC (watts)
- T_{MAX} = Absolute maximum junction temperature (150°C)
- T_A = Free-air temperature (°C)
- θ_{JA} = $\theta_{JC} + \theta_{CA}$
- θ_{JC} = Thermal coefficient from junction to case
- θ_{CA} = Thermal coefficient from case to ambient air (°C/W)

Figure 2–4. Maximum Power Dissipation vs Free-Air Temperature

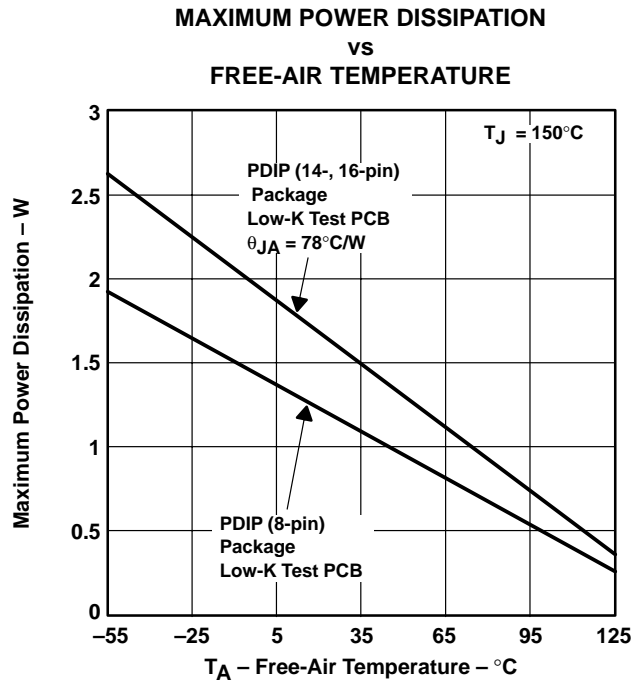

NOTE A: Results are with no air flow and using JEDEC Standard Low-K test PCB.

Table 2–1. Dissipation Rating Table

PACKAGE	θ_{JC} (°C/W)	θ_{JA} (°C/W)	$T_A \leq 25^\circ\text{C}$ POWER RATING
P (8)	41	104	1200 mW
N (14, 16)	32	78	1600 mW

2.6 EVM Component Placement

Figure 2–5 shows component placement for the EVM board.

Figure 2–5. EVM Component Placement

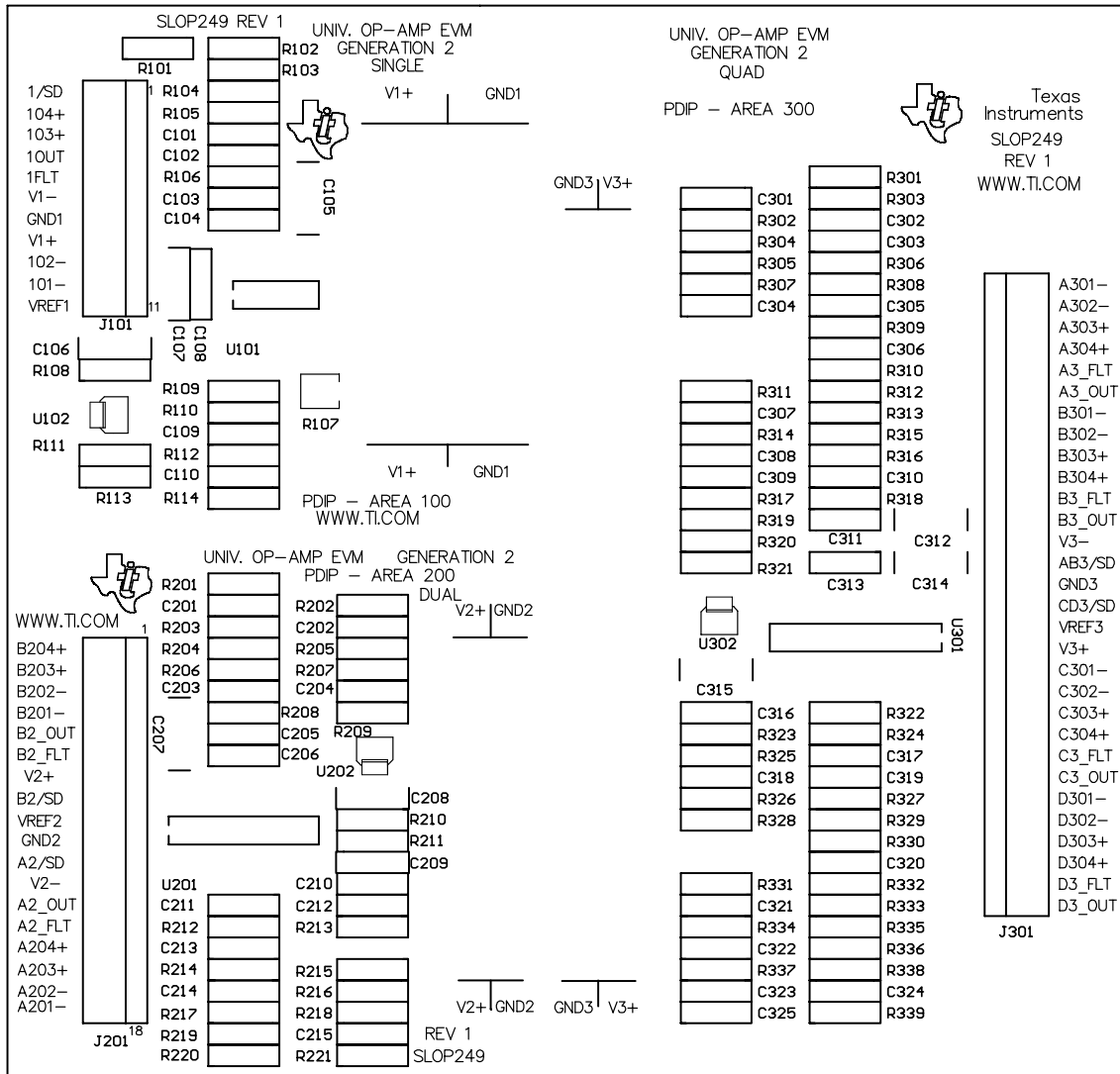

2.7 EVM Board Layout

Figures 2–6 and 2–7 show the EVM top and bottom board layouts, respectively.

Figure 2–6. EVM Board Layout—Top

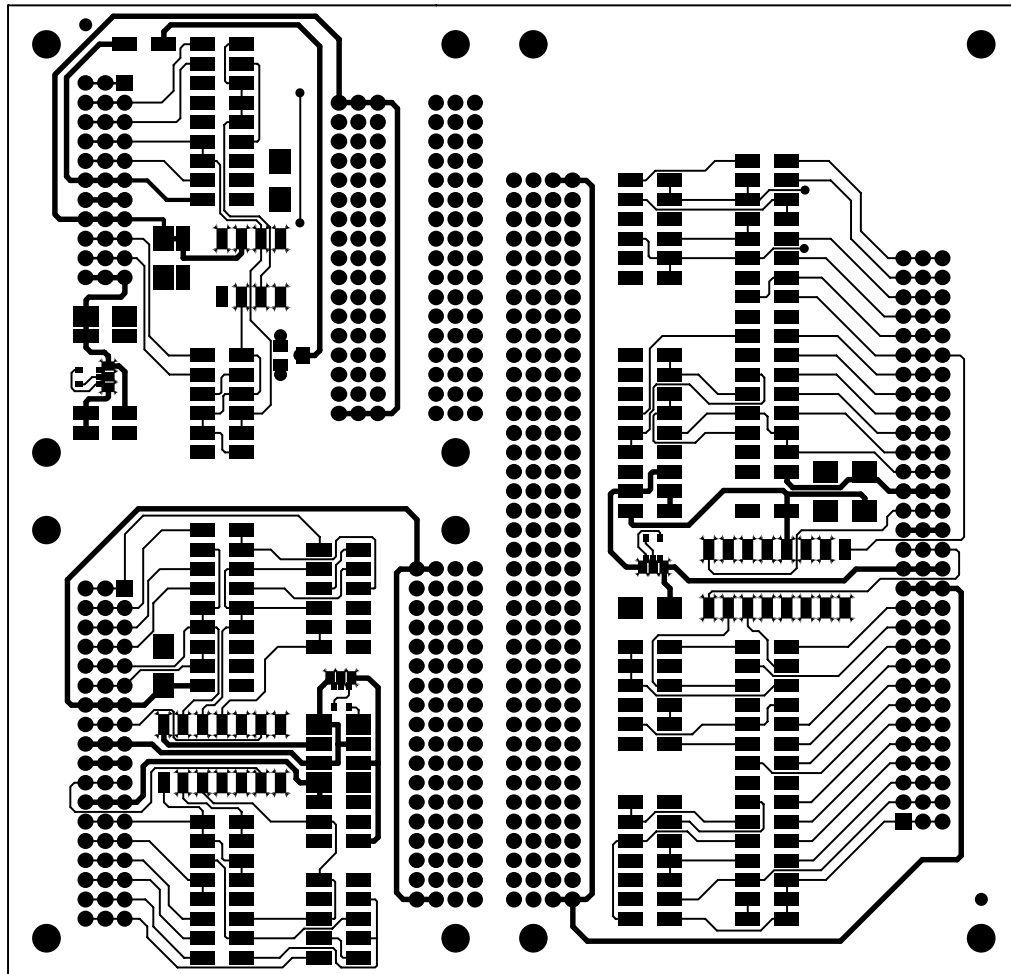
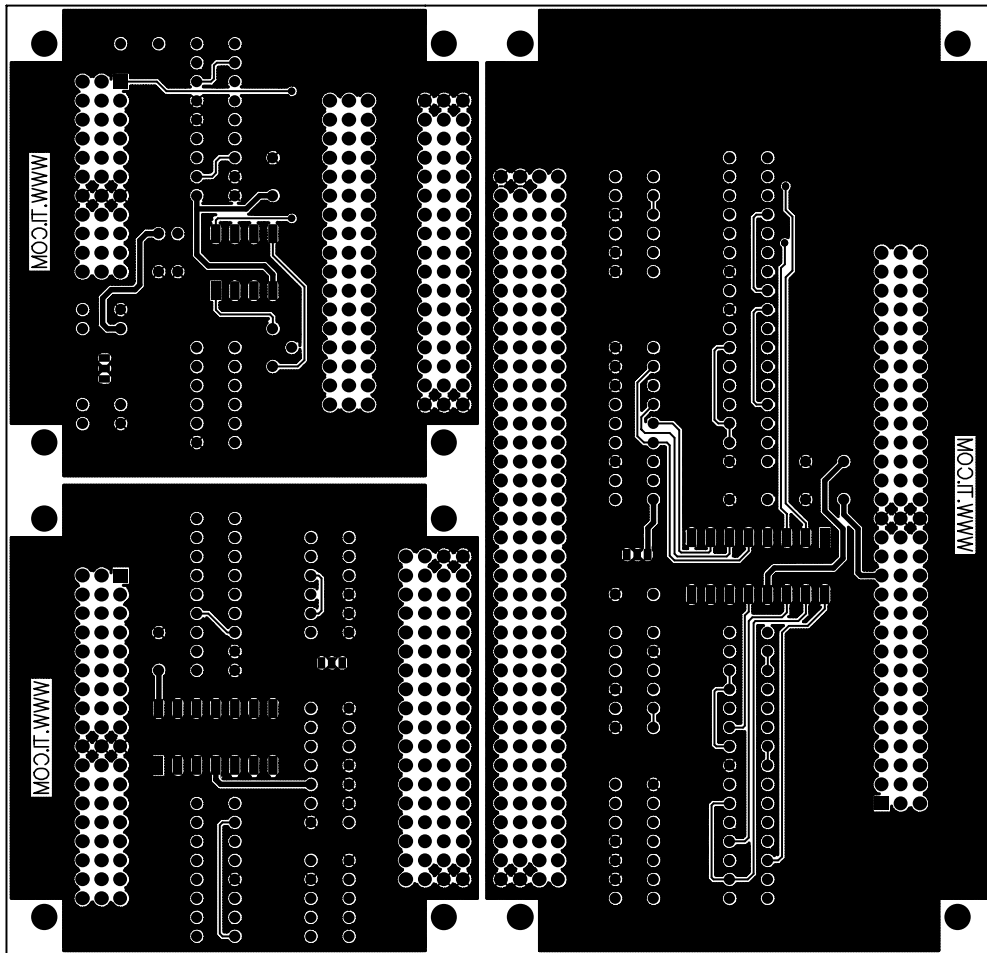

Figure 2–7. EVM Board Layout—Bottom



Example Circuits

This chapter shows and discusses several example circuits that can be constructed using the universal operational amplifier EVM. The circuits are all classic designs that can be found in most operational amplifier design books.

Topic	Page
3.1 Schematic Conventions	3-2
3.2 Inverting Amplifier	3-2
3.3 Noninverting Amplifier	3-3
3.4 Differential Amplifier	3-4
3.5 Sallen-Key Low-Pass Filter	3-5
3.6 Sallen-Key High-Pass Filter	3-6
3.7 Two Operational Amplifier Instrumentation Amplifier	3-8
3.8 Quad Operational Amplifier Instrumentation Amplifier	3-10

3.1 Schematic Conventions

Figures 3–1 through 3–6 show schematic examples of circuits that can be constructed using the universal operational amplifier EVM with shutdown. The components that are placed on the board are shown in bold. Unused components are blanked out. Jumpers and other changes are noted. These examples are only a few of the many circuits that can be built.

3.2 Inverting Amplifier

Figure 3–1 shows area 100 equipped with a single operational amplifier configured as an inverting amplifier using dual power supplies.

Basic setup is done by choice of input and feedback resistors. The transfer function for the circuit as shown is:

$$V_{OUT} = -V_{IN} \frac{R_{112}}{R_{109}}$$

To cancel the effects of input bias current, set $R_{105} = R_{112} \parallel R_{109$, or use a 0-Ω jumper for R105 if the operational amplifier is a low input bias operational amplifier.

Figure 3–1. Inverting Amplifier With Dual Supply Using Area 100

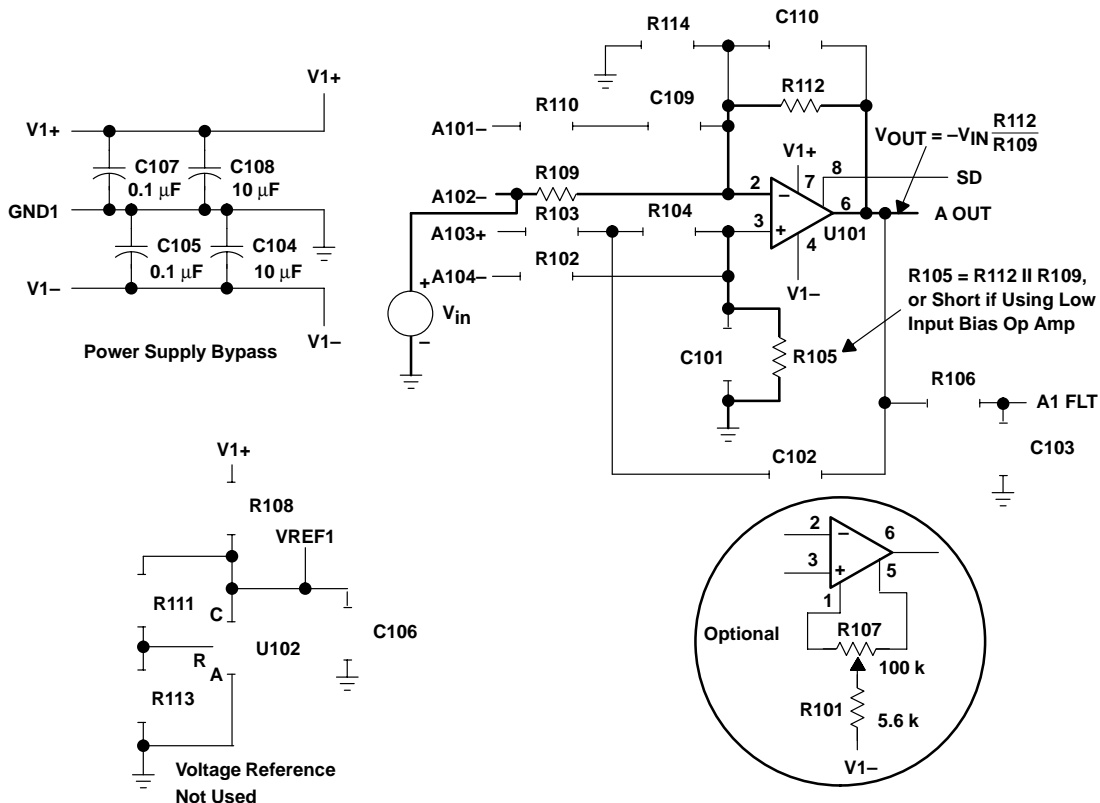

3.3 Noninverting Amplifier

Figure 3–2 shows area 100 equipped with a single operational amplifier configured as a noninverting amplifier with single-supply power input.

Basic setup is done by choice of input and feedback resistors. The transfer function for the circuit as shown is:

$$V_{OUT} = V_{IN} \left(1 + \frac{R_{112}}{R_{109}} \right) + VREF1$$

The input signal must be referenced to VREF1.

To cancel the effects of input bias current, set $R_{102} = R_{112} \parallel R_{109}$, or use a 0- Ω jumper for R102 if the operational amplifier is a low input bias operational amplifier.

The TL431 adjustable precision shunt regulator, configured as shown, provides a low impedance reference for the circuit at about 1/2 V1+ in a 3 V system. Another option is to adjust resistors R113 and R111 for the desired VREF1 voltage. The formula for calculating VREF1 is:

$$VREF1 = 1.24 \text{ V} \left(\frac{R_{111} + R_{113}}{R_{113}} \right)$$

Figure 3–2. Noninverting Amplifier With Single Supply Using Area 100

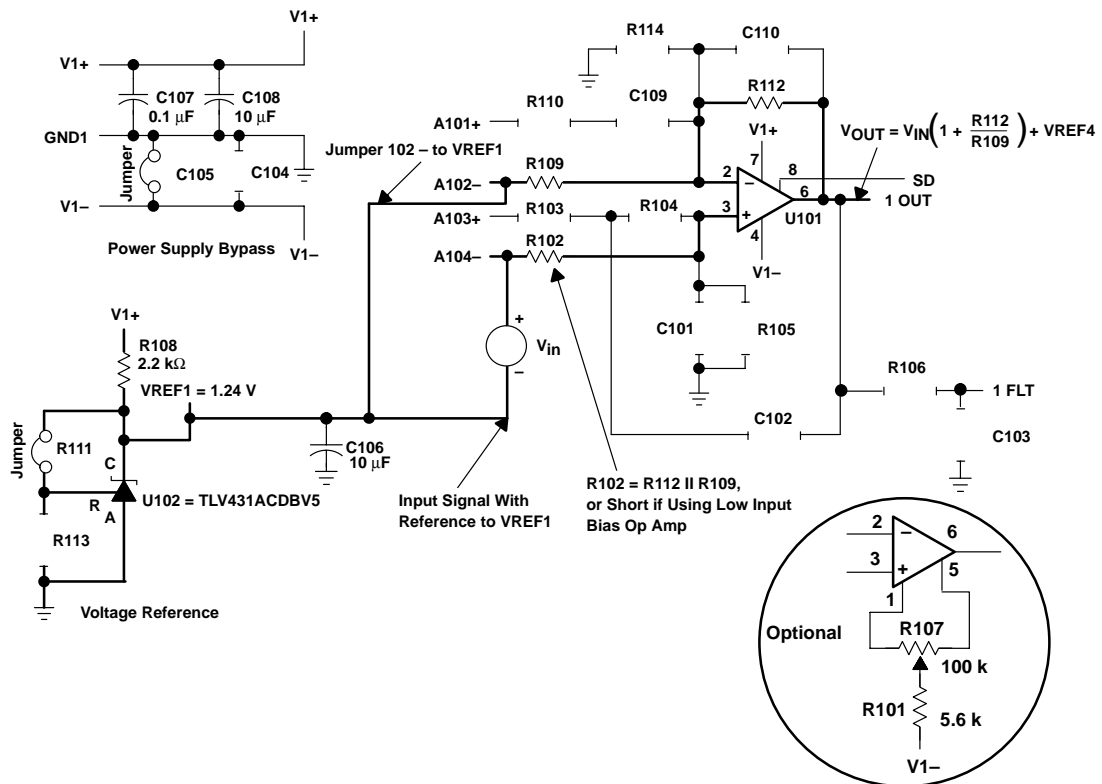

3.4 Differential Amplifier

Figure 3–3 shows area 100 equipped with a single operational amplifier configured as a differential amplifier using a voltage reference and single power supply.

Basic setup is done by choice of input and feedback resistors. The transfer function for the circuit as shown is:

$$V_{OUT} = V_{IN} \left(\frac{R_{112}}{R_{109}} \right) + V_{REF1}$$

Where:

$$\frac{R_{112}}{R_{109}} = \frac{R_{102}}{R_{103}}$$

The TLV431 adjustable precision shunt regulator, configured as shown, provides a low impedance reference for the circuit at about 1/2 V1+ in a 3-V system. Another option is to adjust resistors R111 and R113 for the desired VREF1 voltage. The formula for calculating VREF1 is:

$$V_{REF1} = 1.24 \text{ V} \left(\frac{R_{111} + R_{113}}{R_{113}} \right)$$

Figure 3–3. Single Operational Amplifier Differential Amplifier With Single Supply Using Area 100

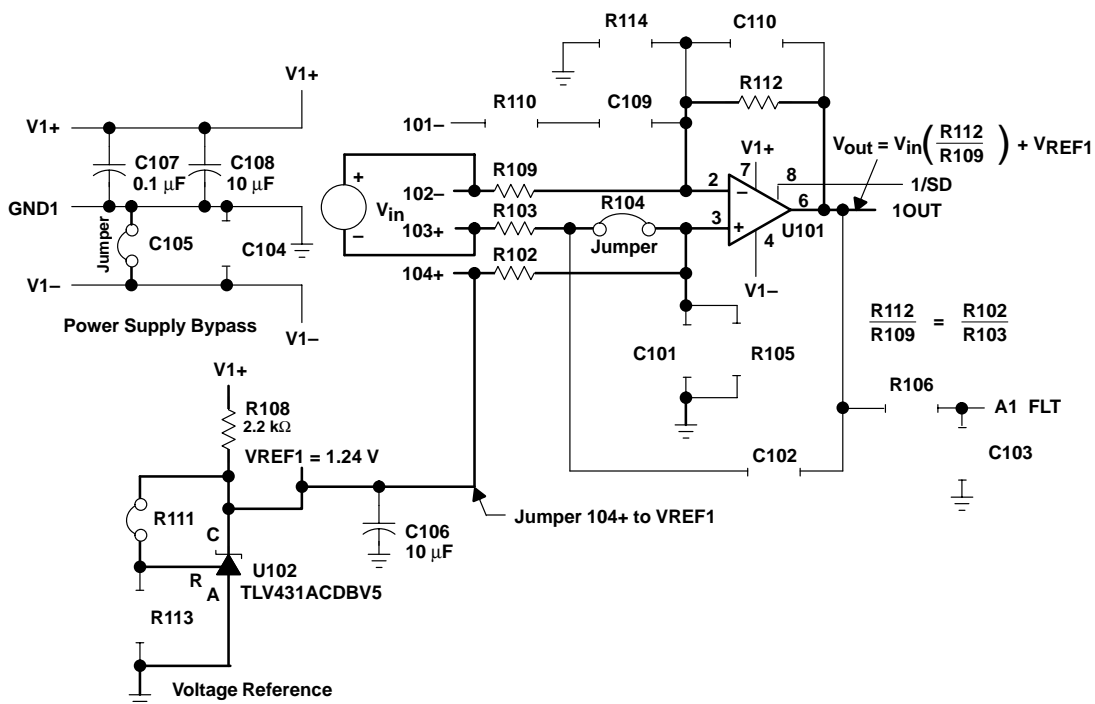

3.5 Sallen-Key Low-Pass Filter

Figure 3-4 shows area 200 equipped with a dual operational amplifier configured as a second-order Sallen-Key low-pass filter using dual-power supplies.

Basic setup is done by proper choice of resistors R and mR, and capacitors C and nC. The transfer function is:

$$\frac{V_{OUT}}{V_{IN}} = \frac{1}{1 - \left(\frac{f}{f_0}\right)^2 + \left(\frac{j}{Q}\right)\left(\frac{f}{f_0}\right)}$$

Where:

$$f_0 = \frac{1}{2\pi \sqrt{m n RC}}$$

And

$$Q = \frac{\sqrt{m n}}{m + 1}$$

Figure 3-4. Sallen-Key Low-Pass Filter With Dual Supply Using Area 200

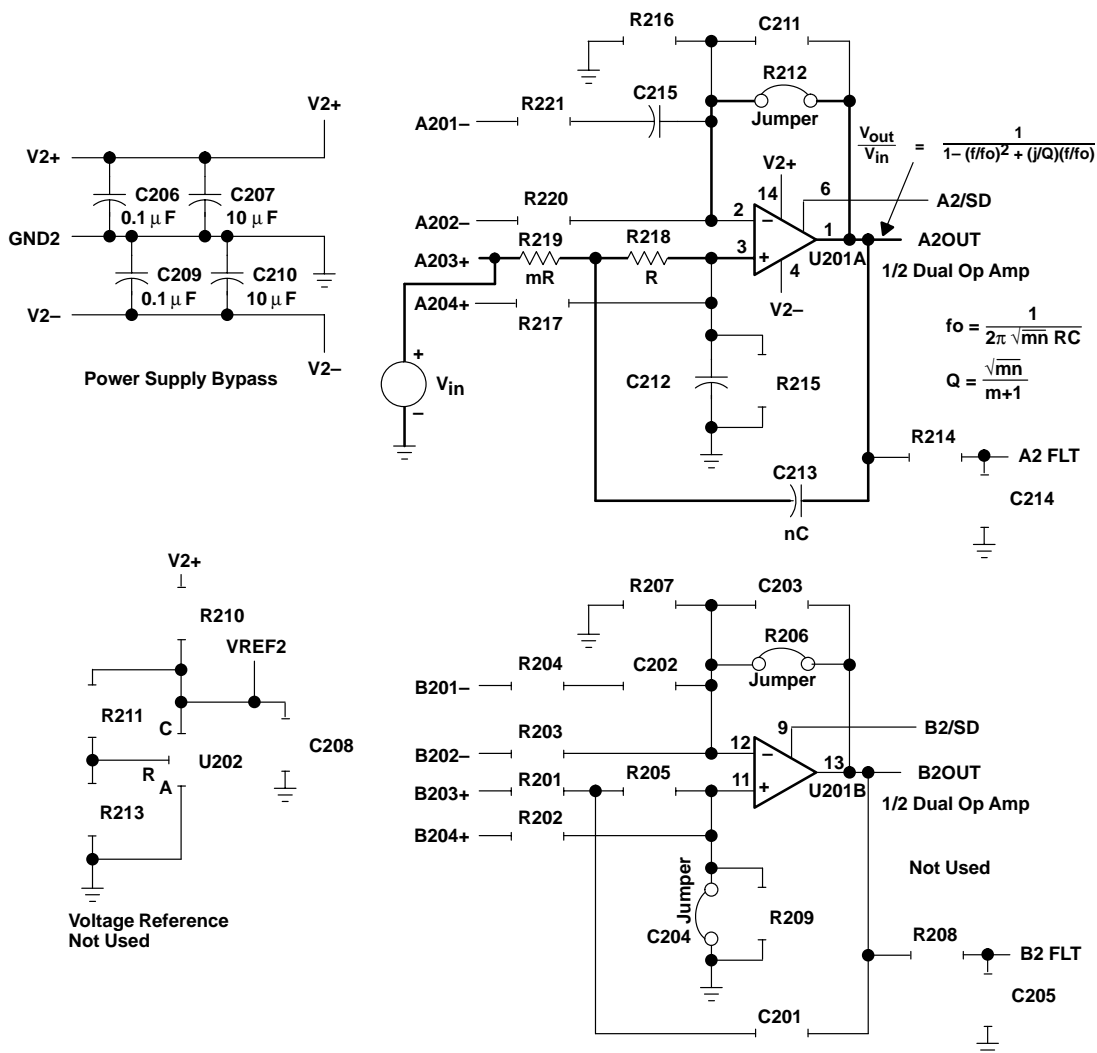

3.6 Sallen-Key High-Pass Filter

Figure 3–5 shows area 200 equipped with a dual operational amplifier configured as a second-order Sallen-Key high-pass filter using single-supply power input.

Basic setup is done by proper choice of resistors R and mR, and capacitors C and nC. Note that capacitors should be used for components R201 and R205, and a resistor for C201. The transfer function for the circuit as shown is:

$$V_{\text{OUT}} = V_{\text{IN}} \times \left[\frac{- \left(\frac{f}{f_0} \right)^2}{1 + \left(\frac{j}{Q} \right) \left(\frac{f}{f_0} \right) - \left(\frac{f}{f_0} \right)^2} \right] + V_{\text{REF2}}$$

Where:

$$f_0 = \frac{1}{2\pi \sqrt{m n} RC}$$

And

$$Q = \frac{\sqrt{m n}}{n + 1}$$

The TL431 adjustable precision shunt regulator, configured as shown, provides a low impedance reference for the circuit at about 1/2 V2+ in a 5 V system. Another option is to adjust resistors R211 and R213 for the desired VREF2 voltage. The formula for calculating VREF2 is:

$$V_{\text{REF2}} = 2.50 \text{ V} \left(\frac{R_{211} + R_{213}}{R_{213}} \right)$$

Figure 3-5. Sallen-Key High-Pass Filter With Single Supply Using Area 200

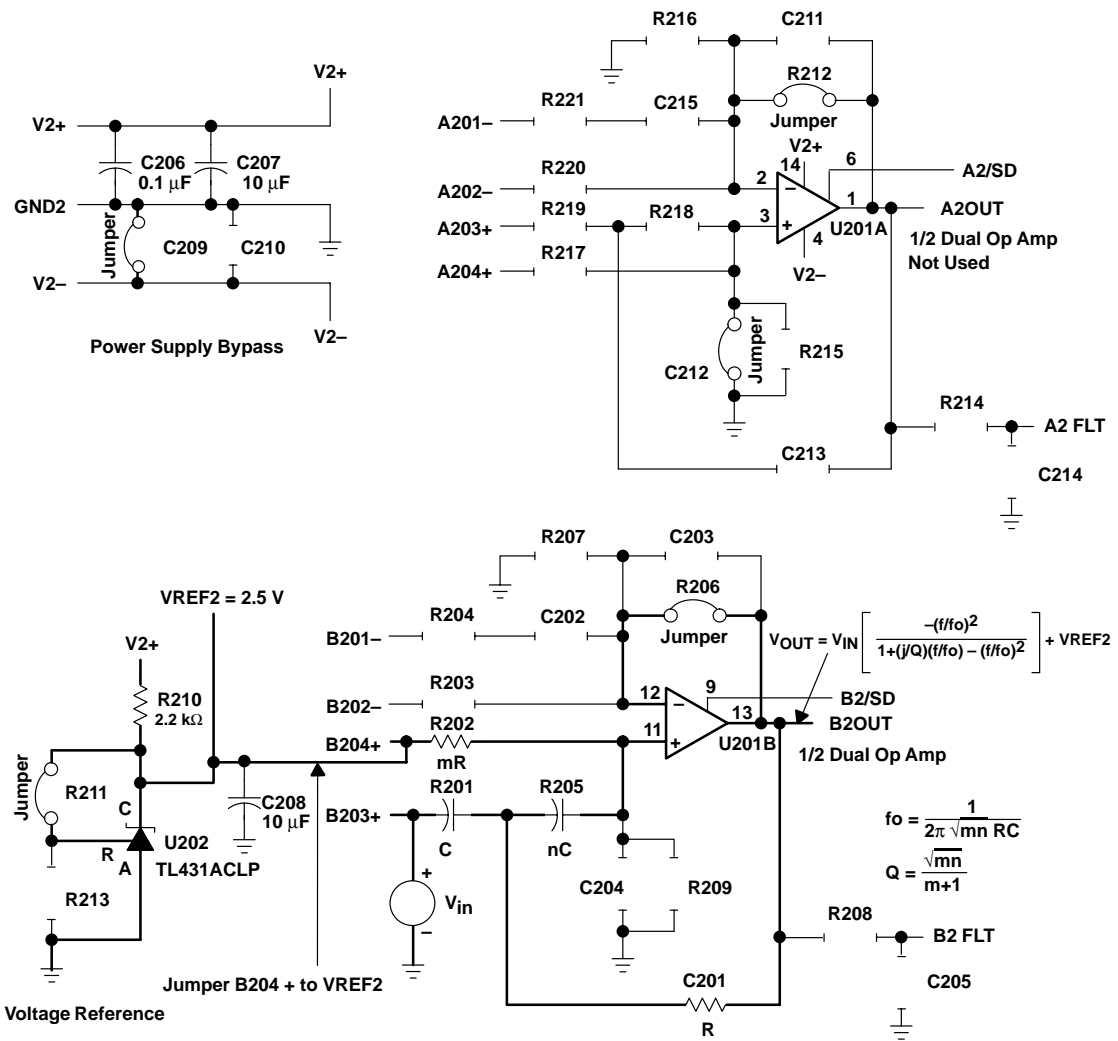

3.7 Two Operational Amplifier Instrumentation Amplifier

Figure 3–6 shows area 200 equipped with a dual operational amplifier configured as a two-operational-amplifier instrumentation amplifier using a voltage reference and single power supply.

Basic setup is done by choice of input and feedback resistors. The transfer function for the circuit as shown is:

$$V_{\text{OUT}} = V_{\text{IN}} \left(1 + \frac{2R_{212}}{R_{220}} + \frac{R_{212}}{R_{221}} \right) + V_{\text{REF2}}$$

Where:

$$R_{212} = R_{206} \text{ and } R_{221} = R_{203}$$

To cancel the effects of input bias current, set $R_{217} = R_{212} \parallel R_{220}$ and set $R_{202} = R_{206} \parallel R_{203}$, or use a 0- Ω jumper for R_{217} and R_{202} if the operational amplifier is a low input bias operational amplifier.

The TLV431 adjustable precision shunt regulator, configured as shown, provides a low impedance reference for the circuit at about 1/2 V_{2+} in a 3 V system. Another option is to adjust resistors R_{211} and R_{213} for the desired V_{REF2} voltage. The formula for calculating V_{REF2} is:

$$V_{\text{REF2}} = 1.24 \text{ V} \left(\frac{R_{211} + R_{213}}{R_{213}} \right)$$

Figure 3-6. Two Operational Amplifier Instrumentation Amplifier With Single Supply Using Area 200

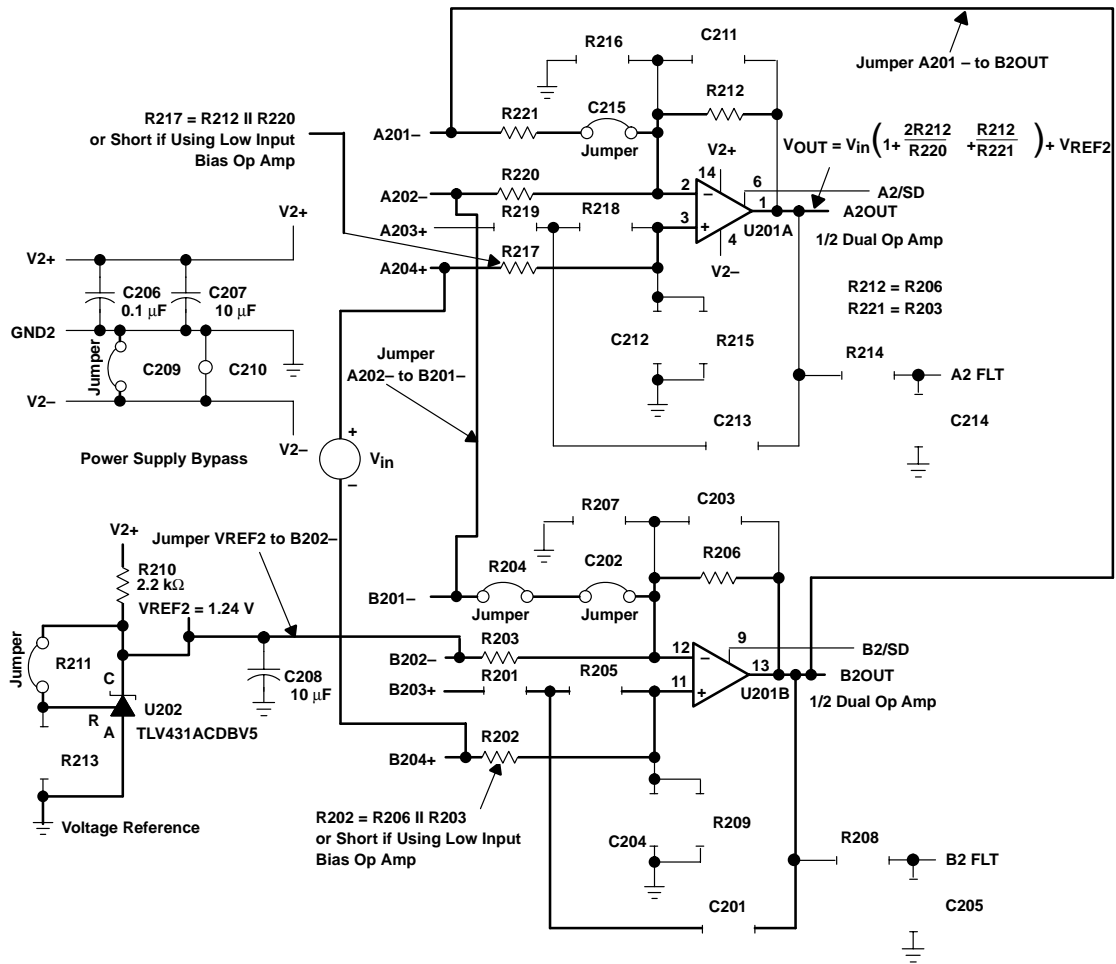

3.8 Quad Operational Amplifier Instrumentation Amplifier

Figure 3–7 shows area 300 equipped with a quad operational amplifier configured as a quad-operational-amplifier instrumentation amplifier using a dual power supply.

Basic setup is done by choice of input and feedback resistors. The transfer function for the circuit as shown is:

$$V_{\text{OUT}} = (V_{\text{INB}} - V_{\text{INA}}) \left(\frac{R303 + 2(R302)}{R303} \right) + \frac{R325}{R309}$$

Where:

$$R302 = R318, R309 = R316, \text{ and } R325 = R329$$

$$A_V = \left(\frac{R303 + 2(R302)}{R303} \right) + \frac{R325}{R309} = 101 \text{ as shown}$$

To cancel the effects of offset errors, adjust V_{adj} (D304+) by applying an extra signal.

Figure 3-7. Quad Operational Amplifier Instrumentation Amplifier With Dual Supply Using Area 300

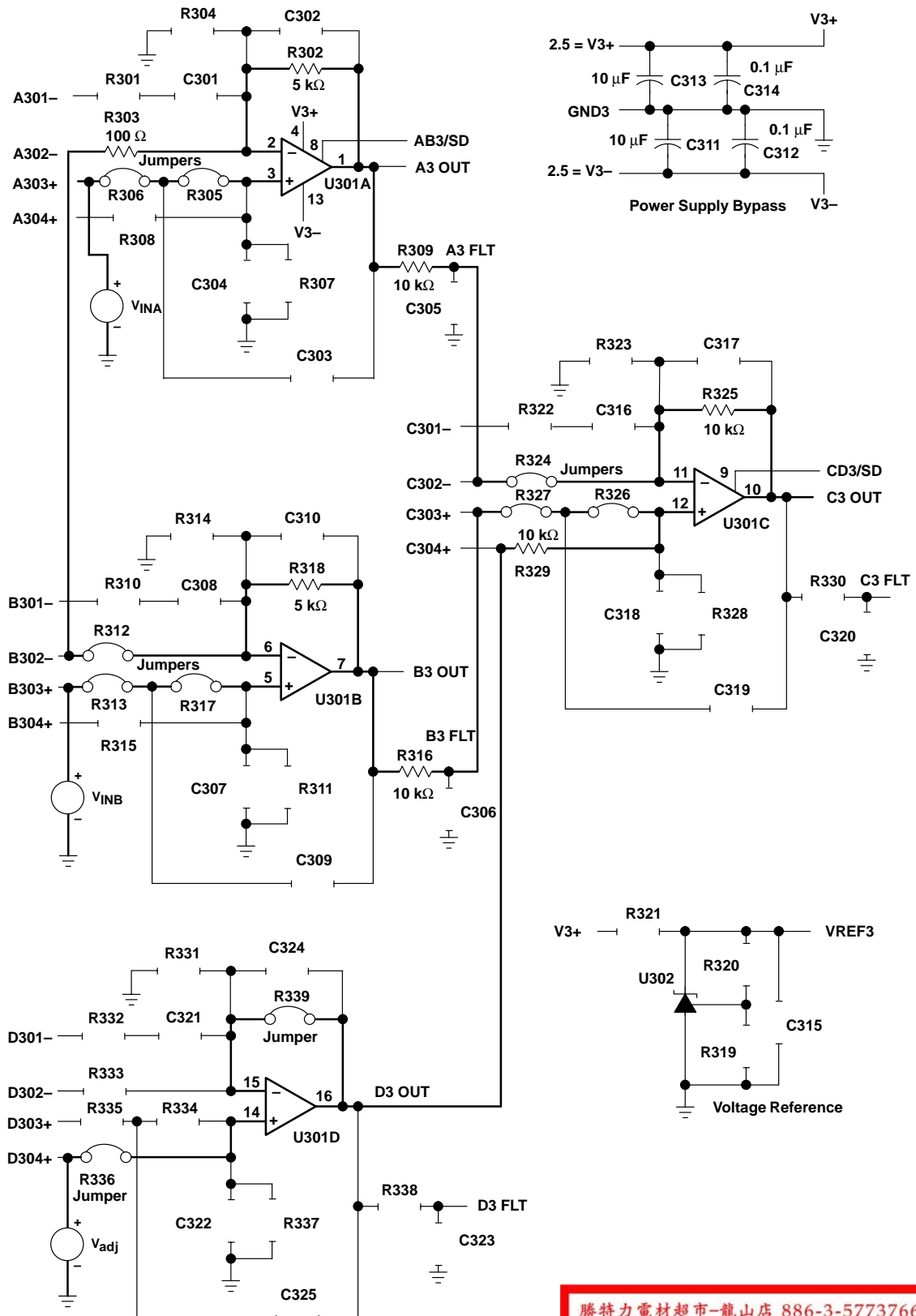

勝特力電材超市-龍山店 886-3-5773766
 勝特力電材超市-光復店 886-3-5729570
 勝特力電子(上海) 86-21-34970699
 勝特力電子(深圳) 86-755-83298787
<http://www.100y.com.tw>