

Contents

1. Product's picture
2. Feature
3. Pins description
4. The parameters and mode of product
5. Block diagram
6. Debugging device
7. Characteristic of test
8. Test diagram
9. AT command set

勝特力材料 886-3-5753170
勝特力电子(上海) 86-21-34970699
勝特力电子(深圳) 86-755-83298787
[Http://www.100y.com.tw](http://www.100y.com.tw)

1. Product's picture

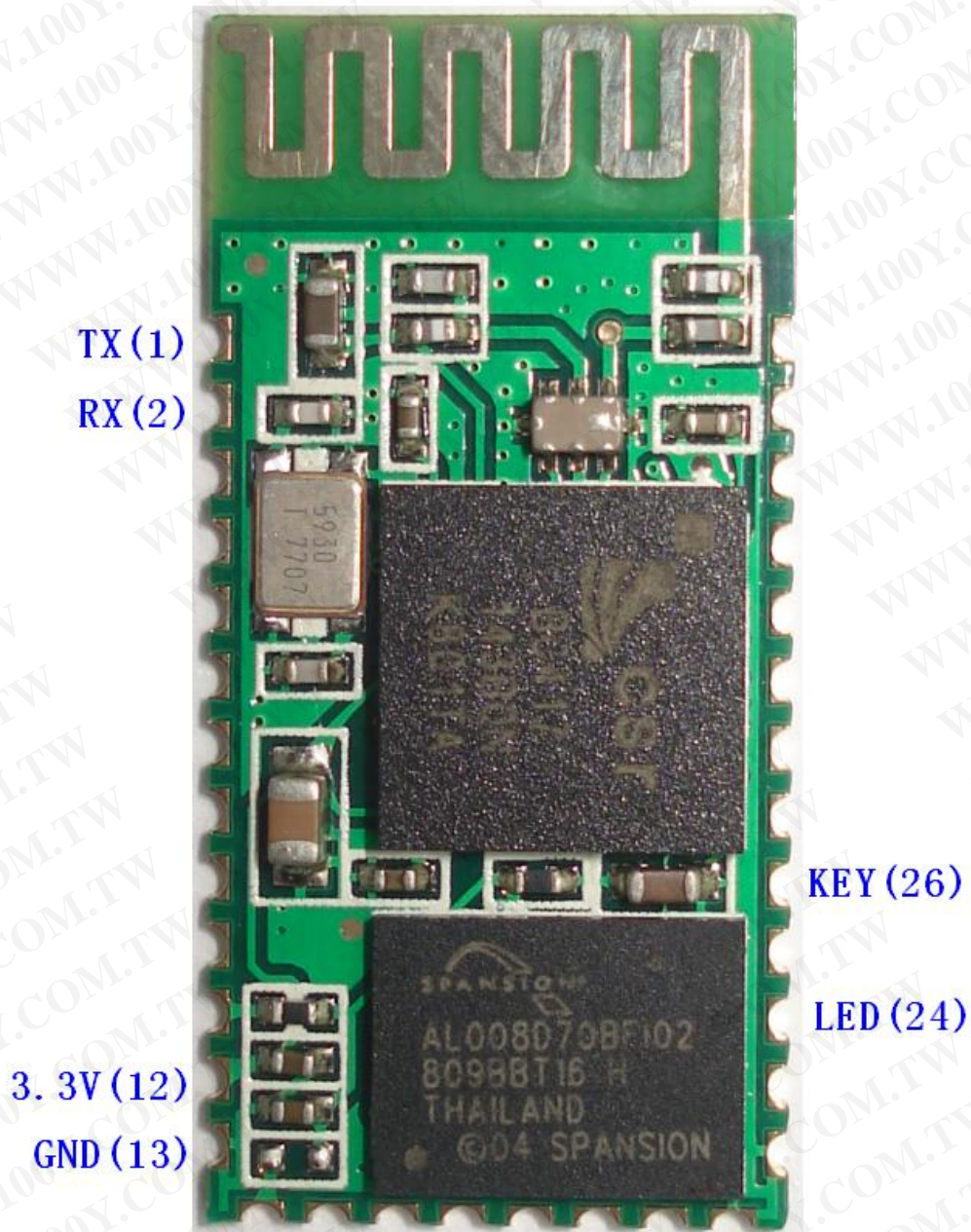

Figure 1 A Bluetooth module

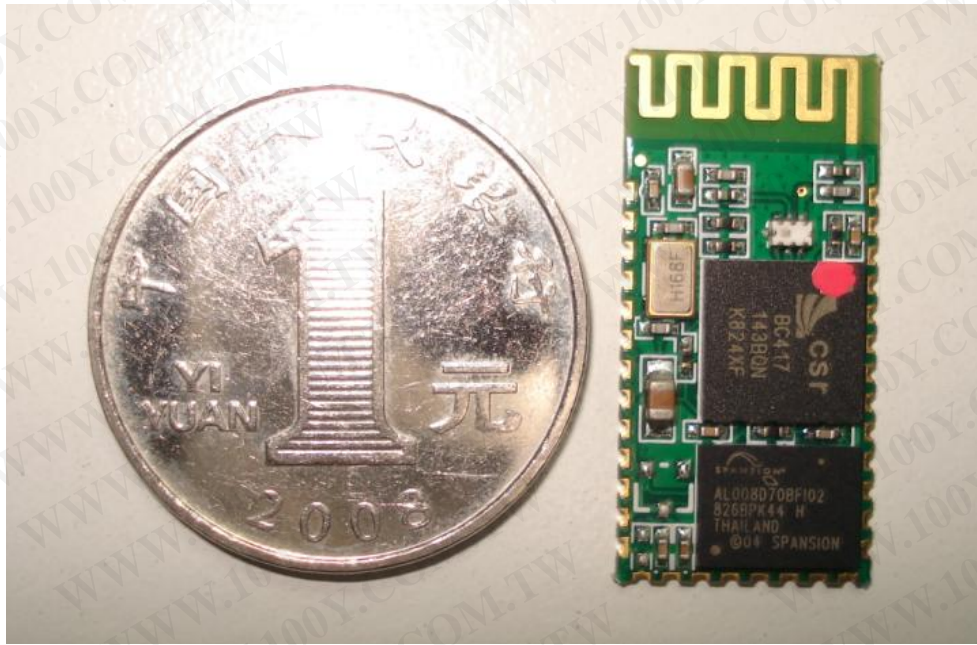

Figure 2. A Bluetooth module size



Figure 3 50 pieces chips in an anti-static blister package.

2. Feature

- Wireless transceiver
 - Sensitivity (Bit error rate) can reach -80dBm.
 - The change range of output's power: -4 - +6dBm.
- Function description (perfect Bluetooth solution)
 - Has an EDR module; and the change range of modulation depth: 2Mbps - 3Mbps.
 - Has a build-in 2.4GHz antenna; user needn't test antenna.
 - Has the external 8Mbit FLASH
 - Can work at the low voltage (3.1V~4.2V). The current in pairing is in the range of 30~40mA. The current in communication is 8mA.
 - Standard HCI Port (UART or USB)
 - USB Protocol: Full Speed USB1.1, Compliant With 2.0
 - This module can be used in the SMD.
 - It's made through RoHS process.
 - The board PIN is half hole size.
 - Has a 2.4GHz digital wireless transceiver.
 - Bases at CSR BC04 Bluetooth technology.
 - Has the function of adaptive frequency hopping.
 - Small (27mm×13mm×2mm)
 - Peripherals circuit is simple.
 - It's at the Bluetooth class 2 power level.
 - Storage temperature range: -40 °C - 85°C, work temperature range: -25 °C - +75°C
 - Any wave inter Interference: 2.4MHz, the power of emitting: 3 dBm.
 - Bit error rate: 0. Only the signal decays at the transmission link, bit error may be produced. For example, when RS232 or TTL is being processed, some signals may decay.
- Low power consumption
- Has high-performance wireless transceiver system
- Low Cost

- Application fields:
 - Bluetooth Car Handsfree Device
 - Bluetooth GPS
 - Bluetooth PCMCIA , USB Dongle
 - Bluetooth Data Transfer
- Software
 - CSR

3. PINs description

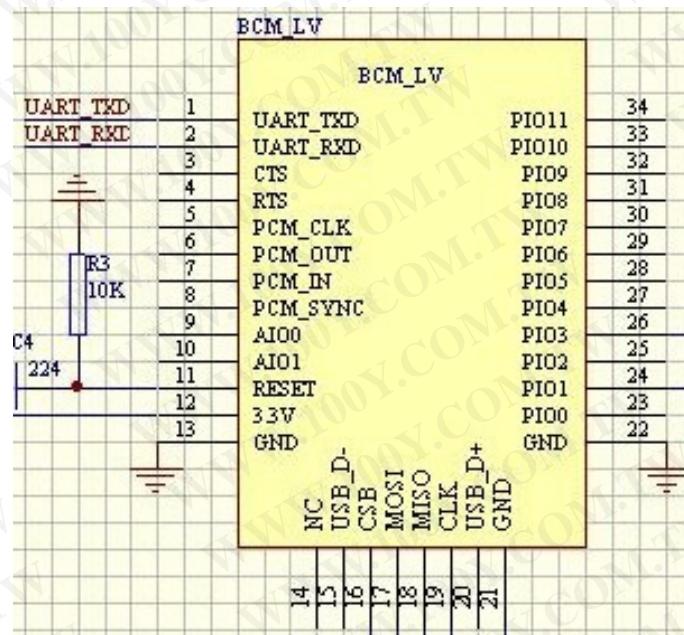

Figure 3 PIN configuration

The PINs at this block diagram is as same as the physical one.

PIN Name	PIN #	Pad type	Description	Note
GND	13 21 22	VSS	Ground pot	
1V8	14	VDD	Integrated 1.8V (+) supply with On-chip linear regulator output within 1.7-1.9V	
VCC	12	3.3V		
AIO0	9	Bi-Directional	Programmable input/output line	
AIO1	10	Bi-Directional	Programmable input/output line	

PIO0	23	Bi-Directional RX EN	Programmable input/output line, control output for LNA(if fitted)	
PIO1	24	Bi-Directional TX EN	Programmable input/output line, control output for PA(if fitted)	
PIO2	25	Bi-Directional	Programmable input/output line	
PIO3	26	Bi-Directional	Programmable input/output line	
PIO4	27	Bi-Directional	Programmable input/output line	
PIO5	28	Bi-Directional	Programmable input/output line	
PIO6	29	Bi-Directional	Programmable input/output line	CLK_REQ
PIO7	30	Bi-Directional	Programmable input/output line	CLK_OUT
PIO8	31	Bi-Directional	Programmable input/output line	
PIO9	32	Bi-Directional	Programmable input/output line	
PIO10	33	Bi-Directional	Programmable input/output line	
PIO11	34	Bi-Directional	Programmable input/output line	
RESETB	11	CMOS Input with weak internal pull-down		
UART_RTS	4	CMOS output, tri-stable with weak internal pull-up	UART request to send, active low	
UART_CTS	3	CMOS input with weak internal pull-down	UART clear to send, active low	
UART_RX	2	CMOS input with weak internal pull-down	UART Data input	
UART_TX	1	CMOS output, Tri-stable with weak internal pull-up	UART Data output	
SPI_MOSI	17	CMOS input with weak internal pull-down	Serial peripheral interface data input	
SPI_CSB	16	CMOS input with weak internal	Chip select for serial peripheral interface, active low	

		pull-up		
SPI_CLK	19	CMOS input with weak internal pull-down	Serial peripheral interface clock	
SPI_MISO	18	CMOS input with weak internal pull-down	Serial peripheral interface data Output	
USB_-	15	Bi-Directional		
USB_+	20	Bi-Directional		
1.8V	14		1.8V external power supply input	Default : 1.8V internal power supply.
PCM_CLK	5	Bi-Directional		
PCM_OUT	6	CMOS output		
PCM_IN	7	CMOS Input		
PCM_SYNC	8	Bi-Directional		

4. The parameters and mode of product

LINVOR BLUE T

www.linvor.com

Bluetooth Module



CSR,BC417143B

V 2.0

2006/09/6

蓝牙 RF 模块

1. 采用 CSR BC4 +8M FLASH 方案
2. 具有 PIO0-PIO11、AIO0、AIO1、
USB、PCM、UART 及 SPI 接口，
模块内置 8MFLASH，功能强大，
用户可定制软件,适用于各种蓝牙
设备，内置 RF 天线,便于调试。

蓝牙协议版本	Bluetooth Specification V2.0 With EDR
USB 协议 USB Protocol	Full Speed USB V1.1 Compliant With USB V2.0
频率	2.4Ghz ISM band
调制方式	GFSK(Gaussian Frequency Shift Keying)
发射功率	-4 ->4 dBm, Class 2
灵敏度	≤-80dBm at 0.1% BER
通讯速率	Asynchronous:2Mbps(Max)
供电电源	3.3V
工作温度	-20~+55 Centigrade
封装尺寸	27mmX13mmX2mm

单位: mm

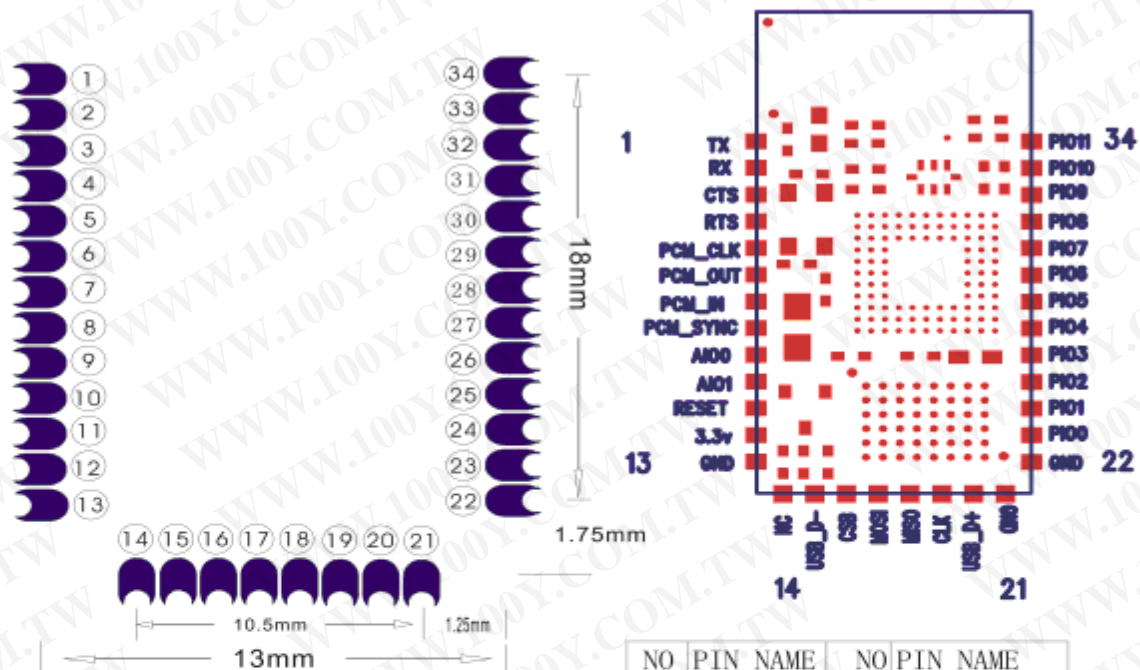

NO	PIN NAME	NO	PIN NAME
1	TX	20	USB D+
2	RX	21	GND
3	CTS	22	GND
4	RTS	23	PI00
5	PCM CLK	24	PI01
6	PCM OUT	25	PI02
7	PCM IN	26	PI03
8	PCM SYNC	27	PI04
9	AI00	28	PI05
10	AI01	29	PI06
11	RESET	30	PI07
12	3.3V	31	PI08
13	GND	32	PI09
14	NC	33	PI010
15	USB D-	34	PI011
16	CSB		
17	MOSI		
18	MISO		
19	CLK		

PCB Layout 请参考实物

5. Block diagram

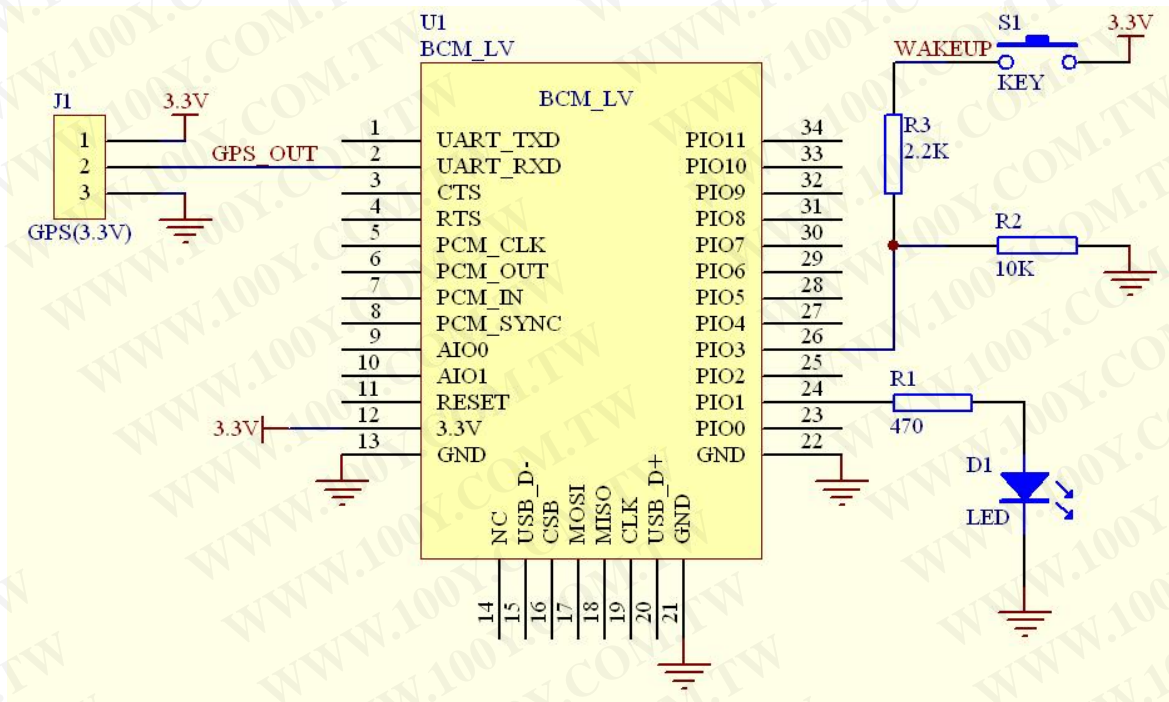

Figure 5 Block diagram 1

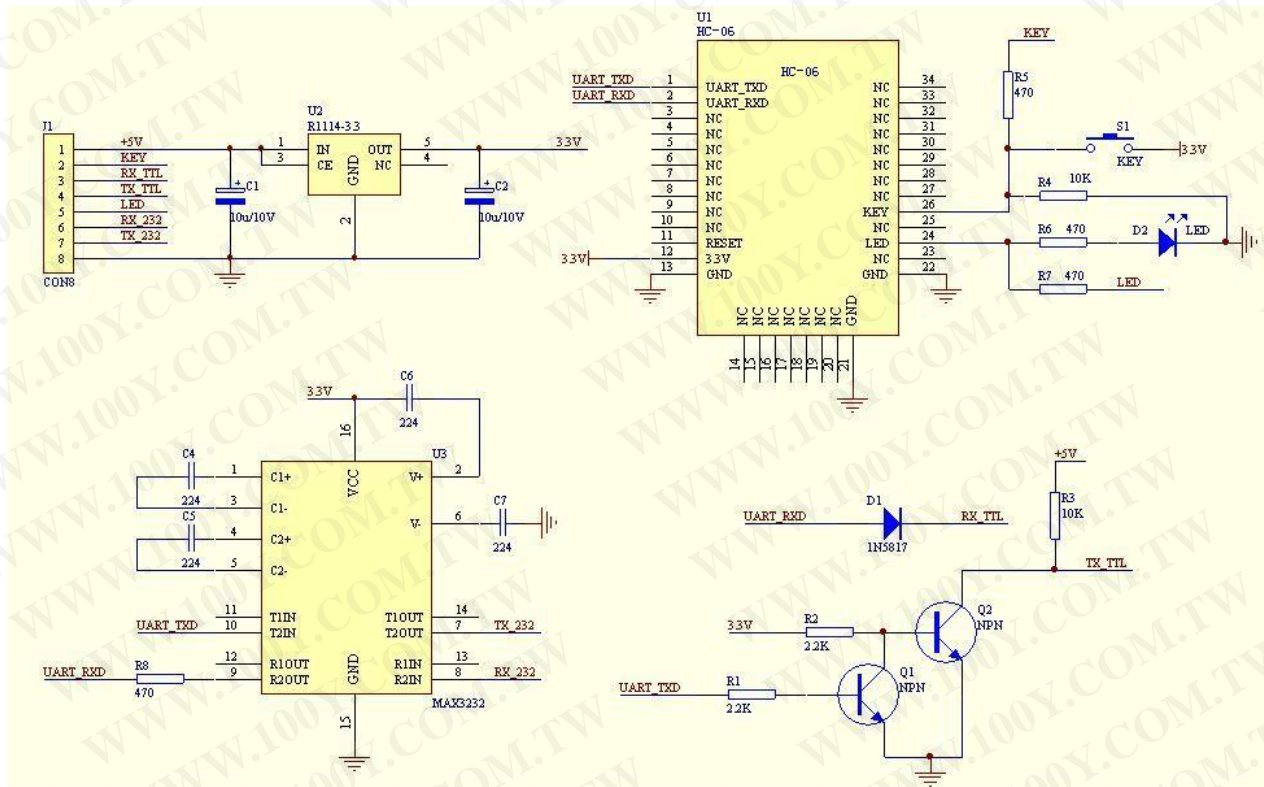

Figure 5 Block diagram 2

HC-04/06 master device has a function of remembering the last paired slave device. As a master device, it will search the last paired slave device until the connection is built. But if the WAKEUP bottom is pressed, HC-04/06 will lose the memory and research the new slave device.

6. Debugging device

6.1 Device

PC, hardware, 3G, 3G Frequency Counter (SP3386), 3.15V DC power supply, Shielding, Bluetooth

Test box.

6.2 Software

7. Characteristic of test

	Test Condition 25°C RH 65%			
	Min	Typ	Max	Unit
1. Carrier Freq. (<i>ISM Band</i>)	2.4		2.4835	MHz
2. RF O/P Power	-6	2	4	dBm
3. Step size of Power control	2		8	dB
4. Freq. Offset (<i>Typical Carrier freq.</i>)	-75		75	KHz
5. Carrier Freq. drift (<i>Hopping on, drift rate/50uS</i>)	-20		20	KHz
1 slot packet	-25		25	KHz
3 slot packet	-40		-40	KHz
6. Average Freq. Deviations (<i>Hopping off, modulation</i>)	140		175	KHz
Freq. Deviation	115			KHz
Ratio of Freq. Deviation	0.8			
7. Receive Sensitivity @< 0.1% BER(<i>Bit error rate</i>)	-83			dBm

8. Test diagram

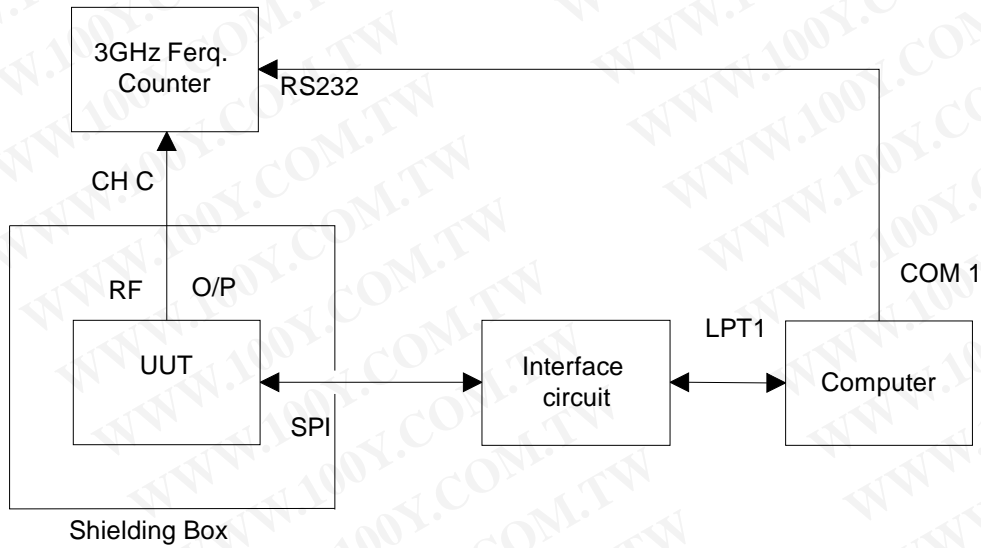
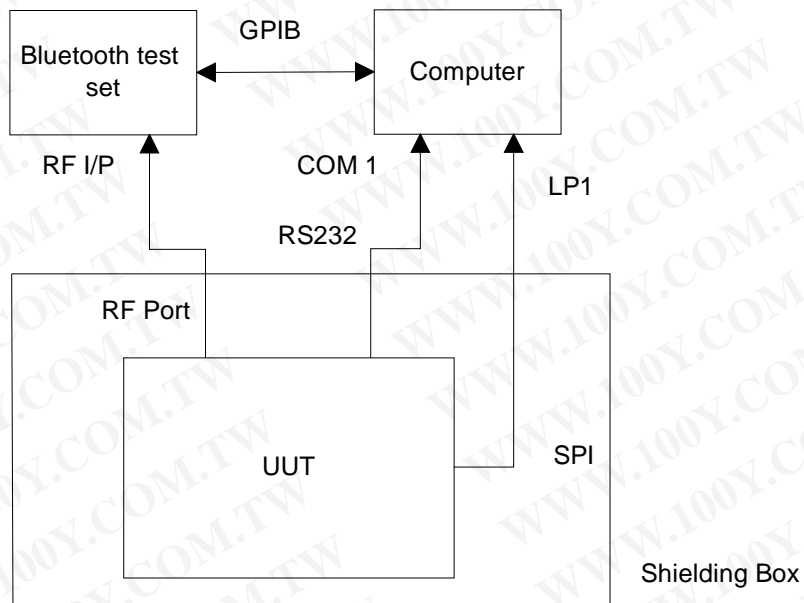

Fig 1. Programming and Freq. Alignment



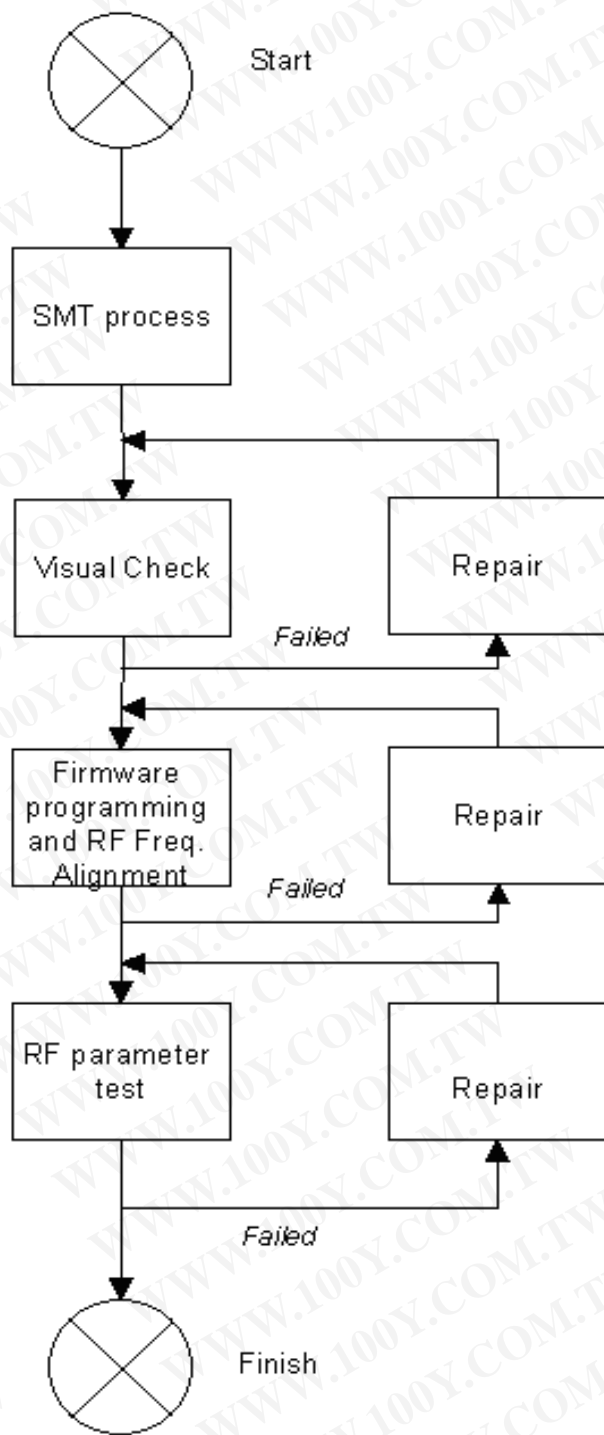

Fig 3 Assemble/Alignment/Testing Flow Chart

9. AT command set

The way to the AT command mode: supply power to the module, it will enter to the AT mode if it needn't pair. The interval of command is about 1 second.

Default parameter: Baud rate:9600N81, ID: linvor, Password:1234

1. Test communication

Send: AT (please send it every second)

Back: OK

2. Reset the Bluetooth serial baud rate

Send: AT+BAUD1

Back: OK1200

Send: AT+BAUD2

Back: OK2400

.....

1-----1200

2-----2400

3-----4800

4-----9600 (Default)

5-----19200

6-----38400

7-----57600

8-----115200

9-----230400

A-----460800

B-----921600

C-----1382400

PC can't support the baud rate lager than 115200. The solution is: make the MCU have higher baud rate (lager than 115200) through programming, and reset the baud rate to low level through the AT command.

The baud rate reset by the AT command can be kept for the next time even though the power is cut off.

3. Reset the Bluetooth name

Send: AT+NAMEname

Back: OKname

Parameter name: Name needed to be set (20 characters limited)

Example:

Send: AT+NAMEbill_gates

Back: OKname

Now, the Bluetooth name is reset to be “bill_gates”

The parameter can be kept even though the power is cut off. User can see the new Bluetooth name in PDA refresh service. (Note: The name is limited in 20 characters.)

4. change the Bluetooth pair password

Send: AT+PINxxxx

Back:OKsetpin

Parameter xxxx: The pair password needed to be set, is a 4-bits number. This command can be used in the master and slave module. At some occasions, the master module may be asked to enter the password when the master module tries to connect the slave module (adapter or cell-phone). Only if the password is entered, the successful connection can be built. At the other occasions, the pair can be finish automatically if the master module can search the proper slave module and the password is correct.

Besides the paired slave module, the master can connect the other devices who have slave module, such as Bluetooth digital camera, Bluetooth GPS, Bluetooth serial printer etc.

Example:

Send: AT+PIN8888

Back: OKsetpin

Then the password is changed to be 8888, while the default is 1234.

This parameter can be kept even though the power is cut off.

5. No parity check (The version, higher than V1.5, can use this command)

Send: AT+PN (This is the default value)

Back: OK NONE

6. Set odd parity check (The version, higher than V1.5, can use this command)

Send: AT+PO

Back: OK ODD

7. Set even parity check(The version, higher than V1.5, can use this command)

Send: AT+PE

Back: OK EVEN

8. Get the AT version

Send: AT+VERSION

Back: LinvorV1.n

勝特力材料 886-3-5753170
勝特力电子(上海) 86-21-34970699
勝特力电子(深圳) 86-755-83298787
[Http://www.100y.com.tw](http://www.100y.com.tw)