

LED process controllers For analogue input signals (AC+DC) **Codix 565**



The process controller Codix 565 with totaliser function displays V and mA analogue input signals in high resolution. In addition it can monitor and control 2 limit values.

These fast displays set new standards when it comes to user friendliness. Their easy-to-read 14-segment LED display, easy-to-understand running help texts and a practical quick-start guide eliminate the need to wade through time-consuming full instruction manuals.

With optional analogue output.

DC 10 ... 30 V Power supply	AC 100 ... 240 V Power supply	A.Z* 6 LEDs 14-segment LED display	Prog Menu-driven programming	mA, V Display linearization	Tara Tare function	Σ Totaliser-Function	mA, V Input	min / max Min / Max value detection	2 2 limit values	AC/DC Galvanic isolation
15 bit Resolution	-20°...+65°C Temperature range	000000 DIN 96 x 48	000000 Installation in mosaic systems	Glove Operation with gloves	mA, V Analogue output optional					

User-friendly

- Practical quick-start guide for setting the parameters and operating the device
- Help text as running text
- Easy-to-read 14-segment LED display, 6 digits 14 mm [0.55] high
- Simple programming via 4 keys on the front
- One front key as well as 2 additional inputs can be programmed for specific applications
- Customer-specific characteristic (linearization) curve via 12 control points for all measurement signal inputs
- MIN/MAX memory function, individually resettable

Powerful

- Sampling rate of 10 readings per second
- Time-controlled totaliser function for totalising the measured values. Can be reset separately.
- 2 relay outputs (changeover contacts) for limit monitoring with hysteresis and ON/OFF delay function for current measured or totaliser values
- Analogue output for the current measured value, MIN-value, MAX-value or totalizer value
- Auxiliary sensor power supply 15 V DC / 25 mA, also for 2-wire transmitters
- Inputs and outputs galvanically isolated
- Digital filter (first-order) for smoothing display fluctuation with unstable input signals
- Tare function

Order code

6.56 5 . 0 1 0 . X 0 X
 a b c d

- a** Input type
5 = Analogue input signal ¹⁾
- b** Outputs
0 = relays ¹⁾
- c** Power supply
0 = 100 ... 240 V AC, ± 10% ¹⁾
3 = 10 ... 30 V DC ¹⁾
- d** Further outputs (optional)
0 = none ¹⁾
9 = analogue output (only for DC version)

- Delivery specification:**
- Process device
 - Mounting clip
 - Gasket
 - Instruction manual, multilingual
 - 1 sheet of self-adhesive symbols
 - Quick-start guide

Practical quick-start guide for setting the parameters and operating the device. The guide can be affixed directly to the front of the unit and can be removed and re-applied as required.



¹⁾ Stock types

Process controllers

LED process controllers For analogue input signals (AC+DC) Codix 565

Accessories	Dimensions in mm [inch]	Order-No.
Mounting frame with cut-out 92 x 45 [3.62 x 1.77]	For snap-on mounting on 35 [1.38] top-hat DIN rail, for counters 96 x 48 [3.74 x 1.89]	grey G300005

Suitable gaskets as well as further accessories can be found in the accessories section or in the accessories area of our website at: www.kuebler.com/accessories.

Technical data

General technical data	
Display	6-digit, 14 segment LED
Digit height	14 mm [0.55"]
Display range	-199999 ... 999999, with leading zero blanking
Data retention	> 10 years, EEPROM
Operation	5 keys
Operating temperature	-20°C ... +65°C [-4°F ... +149°F] (non-condensing)
Storage temperature	-25°C ... +75°C [-13°F ... +167°F]
Relative humidity (non-condensing)	R.H. 93 % at +40°C [+104°F]
Altitude	up to 2000 m [6562']

Mechanical characteristics	
Housing	Panel mount housing to DIN 43700, RAL 7021
Dimensions	96 x 48 x 102 mm [3.78 x 1.89 x 4.02"]
Panel cut-out	92 +0.8 x 45 +0.6 mm [3.62 +0.032 x 1.77 +0.024"]
Installation depth	approx. 92 mm [3.62"] incl. terminals
Weight	approx. 180 g [6.34 oz] with analogue output 200 g [7.06 oz]
Protection	IP65 (front side)
Housing material	Polycarbonate UL94 V-2
Vibration resistance	acc. to EN 60068-2-6 10 - 55 Hz / 1 mm / XYZ 30 min in each direction
Shock resistance	acc. to EN 60068-2-27 100G / XYZ 3 times in each direction acc. to EN 60068-2-29 10G / 6 ms / XYZ 2000 times in each direction
Connections	
Power supply and outputs	Plug-in screw terminal, 8-pin, RM 5.00, core ø max. 2.5 mm² [AWG 13]
Signal and control inputs	Plug-in screw terminal, 9-pin, RM 3.50, core ø max. 1.5 mm² [AWG 15]

Electrical characteristics	
Power supply	AC supply 100 ... 240 V AC / max. 9 VA 50 / 60 Hz, tolerance ±10% ext. fuse protection: T 0.1 A DC supply 10 ... 30 V DC / max. 3.8 W with galvanic isolation and reverse polarity protection ext. fuse protection: T 0.4 A
Mains hum suppression	50 Hz or 60 Hz programmable
Sensor power supply	AC supply 24 V DC ±15 %, 30 mA 15 V DC ± 1 %, 25 mA DC supply 15 V DC ± 1 %, 25 mA
EMC	Emitted interference EN 55011 class B Immunity to interference EN 61000-6-2 with shielded signal and control cables
Device safety	Designed to EN 61010 part 1 Protection class 2 (front side) Application area Pollution level 2 Overvoltage category II
UL approval	File No.: E128604

Measuring signal inputs	
Sampling rate	10 readings/sec
Voltage input	
Input signal	0 ... 10 V, 2 ... 10 V, ± 10 V
Measuring range	-10.5 ... +10.5 V
Resolution	< 0.4 mV (±15 bit)
Measuring accuracy at 23°C [73°F] (% of range)	typ. 0.02 % / max. ≤ 0.05 %
Temperature drift	< 100 ppm / K
Input resistance	1 MΩ
Max. voltage	± 30 V
Current input	
Input signal	0 ... 20 mA, 4 ... 20 mA
Measuring range	-0.5 ... 21 mA
Resolution	1 µA (> 14 bit)
Measuring accuracy at 23°C [73°F] (% of range)	typ. 0.02 % / max. ≤ 0.05 %
Temperature drift	< 100 ppm / K
Input resistance	22 Ω + PTC 25 Ω
Voltage drop	approx. 1.8 V at 20 mA
Max. current	60 mA

Control inputs MPI 1 / MPI 2	
Quantity	2 optocouplers
Function	programmable
Switching levels	LOW < 2 V HIGH > 4 V (max. 30 V)
Pulse length	> 100 ms

Process controllers

LED process controllers For analogue input signals (AC+DC) Codix 565

Analogue output (optional - only for DC version)	
Output ranges	0 (4) ... 20 mA / 0 (2) ... 10 V
Load	current output $\leq 500 \Omega$
	voltage output $\geq 2000 \Omega$
Resolution	15 bit
Update time (basic device measuring rate)	100 ms
Temperature drift	≤ 100 ppm/K
Accuracy	$\pm 0.1\%$ of the output range high value
Output ripple	≤ 10 mV
Isolation voltage	500 V AC for 1 minute or 1 kV DC for 1 second

Alarm outputs	
Relays	changeover contacts
Switching voltage	max. 250 V AC / 125 V DC
	min. 5 V AC / 5 V DC
Switching current	max. 5 A AC / 5 A DC
	min. 10 mA DC
Switching capacity	max. 1250 VA / 150 W

Block diagram

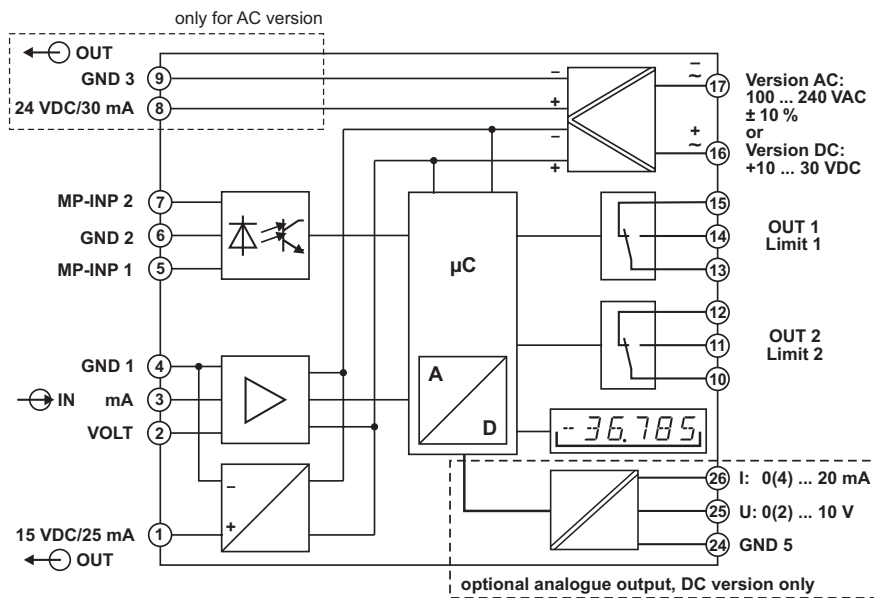

Process controllers

LED process controllers For analogue input signals (AC+DC) Codix 565

Terminal assignment

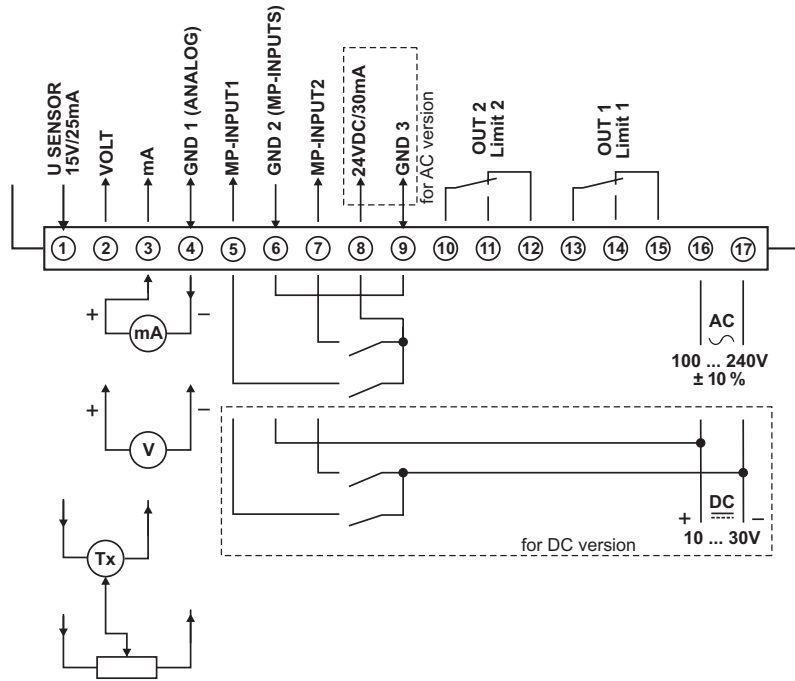

Rear side view

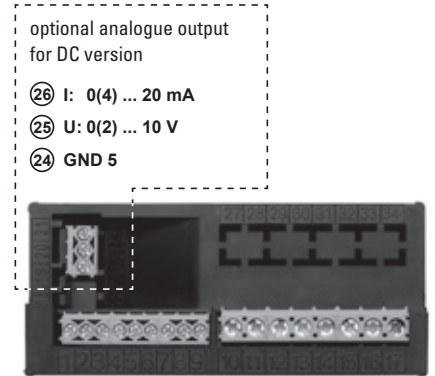

Dimensions

Dimensions in mm [inch]

Panel cut-out
 $92^{+0.8} \times 45^{+0.6}$
 $[3.62^{+0.032} \times 1.77^{+0.024}]$

