

規格書 | 產品型號: 855-305/200-501

插入式電流變換器; 一次額定電流 : 200 A; 二次額定電流 : 5 A; 額定功率 : 5 VA; 精度等級 : 1

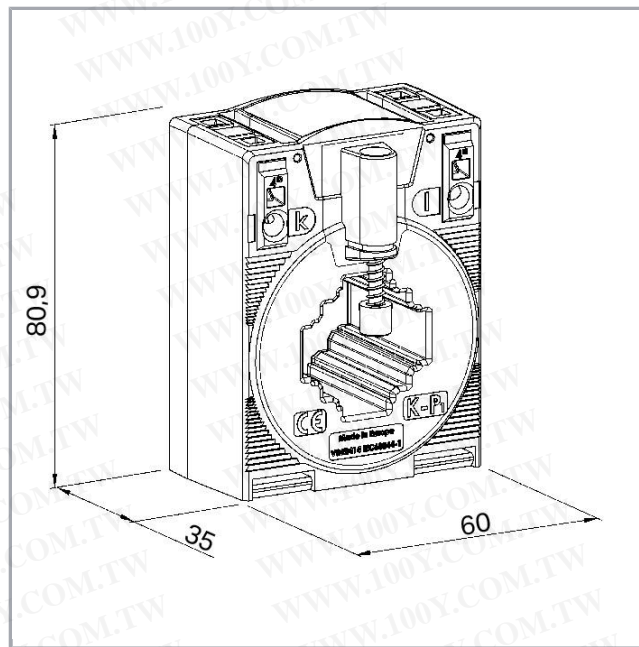

www.wago.com/855-305/200-501



RoHS Compliant



勝特力材料 886-3-5753170
勝特力电子(上海) 86-21-34970699
勝特力电子(深圳) 86-755-83298787
[Http://www.100y.com.tw](http://www.100y.com.tw)

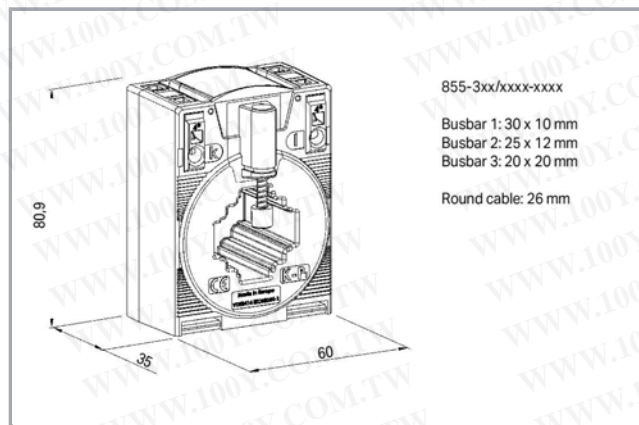
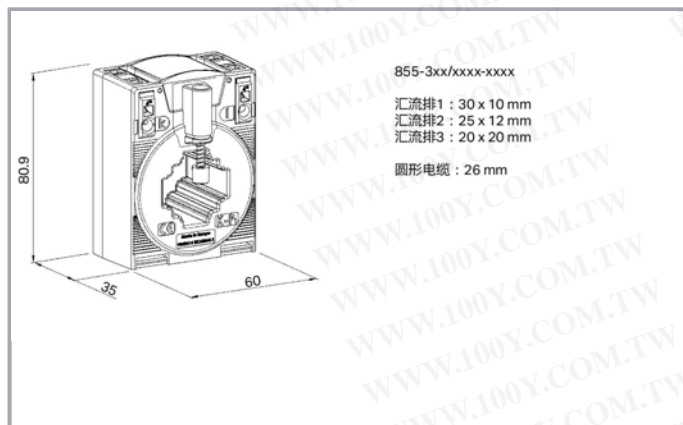

產品描述

簡要描述：

855 系列穿透式比流器為電感單導線比流器。由於所使用的測量原理，這些比流器專用於 AC 網路應用。

特點：

- 無螺絲 CAGE CLAMP® 連接技術
- 有多個安裝位置
- 抗震
- 高機械保持力
- 高電流承載能力
- 120 % 主電流連續 過載
- 適用於最大工作電壓達 1.2 kV 的低壓比流器
- 可用於 690 V 的電源網路
- UL 認證的元件

資料

Technical Data

Input – current transformer

Primary rated current	200 A
Rated continuous thermal current I_{cth}	$1.2 \times I_N$
Rated short-time thermal current I_{th}	$60 \times I_N / 1 \text{ s (max. } 100 \text{ kA / 1 s)}$
過電流限制因素 FS	FS5 或 FS10 (相關類型請參閱類型板說明)
額定頻率	50 ... 60 Hz

Output – Current transformer

Secondary rated current	5 A
額定功率	5 VA

Measurement error

精度等級	1
------	---

安全和保護：

Highest voltage for equipment U_m	AC 1.2 kV _{rms}
-------------------------------------	--------------------------



Test voltage	AC 6 kV; 50 Hz; 1 min
連接資料	
連接技術	CAGE CLAMP®
單芯導線	0.08 ... 4 mm ² / 28 ... 12 AWG
細多芯導線	0.08 ... 4 mm ² / 28 ... 12 AWG
剝線長度	9 ... 10 mm / 0.35 ... 0.39 英寸
幾何數據	
寬度	60 mm / 2.362 inch
高度	80.9 mm / 3.185 inch
深度	52 mm / 2.047 inch
機械資料	
安裝類型	比流器 (關閉) 固定到安裝板 使用導軌固定支架安裝軌道上 安裝於圓形電纜上
材料資料	
Insulation class	E
重量	324 g
環境條件	
(工作) 環境溫度	-5 ... 50 °C
(存儲) 環境溫度	-25 ... 70 °C
Max. operating altitude	1000 m
標準和規範 :	
一致性標記	CE
標準/規格	EN 61869-2:2012
商業資料	
包裝類型	BOX
Country of origin	DE
GTIN	4050821749356

Customs Tariff No.

85043129900

認證 / 證書

UL-Approvals

標誌	認證	其他認證資訊	認證名稱
	UL Underwriters Laboratories Inc.	-	E356480

Counterpart

相容產品

General accessories

	產品編號: 2007-8873 緊湊型接線端子台; 適用於比流器和比壓器; 6,00 mm ² ; 五彩色	www.wago.com/2007-8873
	產品編號: 2007-8874 緊湊型接線端子台; 適用於比流器和比壓器; 6,00 mm ² ; 五彩色	www.wago.com/2007-8874
	產品編號: 2007-8875 緊湊型接線端子台; 適用於比流器電路; 6,00 mm ² ; 五彩色	www.wago.com/2007-8875
	產品編號: 2007-8876 緊湊型接線端子台; 適用於3相比流器電路; 6,00 mm ² ; 五彩色	www.wago.com/2007-8876
	產品編號: 2007-8877 緊湊型接線端子台; 適用於比流器電路; 6,00 mm ² ; 五彩色	www.wago.com/2007-8877
	產品編號: 2857-570/024-005 三相電力信號轉換器; 3x400/690V/5A; Modbus RTU; 數位輸出; 通過軟體配置; 電源電壓: 24 VDC	www.wago.com/2857-570/024-005
	產品編號: 857-550 電流信號調變器; 電流輸入信號; 電流和電壓輸出信號; 數位輸出; 通過軟體配置; 電源電壓: 24 VDC; 6 mm 模組寬度; 2,50 mm ²	www.wago.com/857-550
	產品編號: 857-569 功率信號轉換器; 電流和電壓輸入信號; 電流和電壓輸出信號; 數位輸出; 通過軟體配置; 電源電壓: 24 VDC; 6 mm 模組寬度	www.wago.com/857-569

tools



產品編號: 210-720

操作工具; (3.5 x 0.5) mm; 帶有絕緣手柄

www.wago.com/210-720

assembling



產品編號: 855-9900

支架軌道介面卡

www.wago.com/855-9900



產品編號: 855-9910

線纜固定元件

www.wago.com/855-9910

下載

Documentation

Additional Information

Disposal; Electrical and electronic equipment, Packaging

V 1.0.0

pdf
265.8 kB

下載

Engineering-Software

Software for Interface-Products

WAGO Interface Configuration Software SMALL

The full setup only includes the WAGO Interface Configuration Software.

1.6.3.7
2019/9/17

exe
48.0 MB

下載

WAGO Interface Configuration Software FULL

The full setup, in addition to the WAGO Interface Configuration Software, includes the installation for the Microsoft .NET Framework.

1.6.3.7
2019/9/17

exe
98.5 MB

下載

CAD/CAE-Data

CAD data

2D/3D Models 855-305/200-501

URL

下載

CAE data

EPLAN Data Portal 855-305/200-501

下載

WSCAD Universe 855-305/200-501

下載

Installation Notes

Inserting a conductor



Inserting a conductor – Operating tool actuation perpendicular to conductor entry.



Inserting a conductor – Operating tool actuation parallel to conductor entry.

勝特力材料 886-3-5753170
勝特力电子(上海) 86-21-34970699
勝特力电子(深圳) 86-755-83298787
[Http://www.100y.com.tw](http://www.100y.com.tw)

Assembly

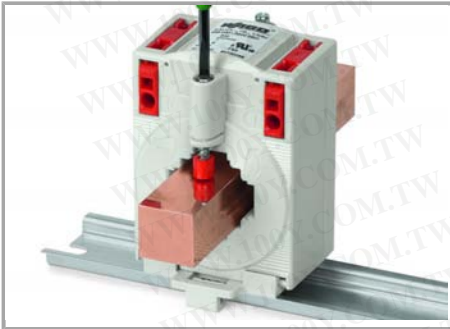

Mounting on copper carrier rail



Mounting on round cable



Secured to mounting plate



Mounting on DIN-rail via carrier rail adapter
855-9900



Mounting via quick-mount kit 855-9910