



December 1994

54F/74F32 Quad 2-Input OR Gate

General Description

This device contains four independent gates, each of which performs the logic OR function.

Features

- Guaranteed 4000V minimum ESD protection

Commercial	Military	Package Number	Package Description
74F32PC		N14A	14-Lead (0.300" Wide) Molded Dual-In-Line
	54F32DM (Note 2)	J14A	14-Lead Ceramic Dual-In-Line
74F32SC (Note 1)		M14A	14-Lead (0.150" Wide) Molded Small Outline, JEDEC
74F32SJ (Note 1)		M14D	14-Lead (0.300" Wide) Molded Small Outline, EIAJ
	54F32FM (Note 2)	W14B	14-Lead Cerpack
	54F32LM (Note 2)	E20A	20-Lead Ceramic Leadless Chip Carrier, Type C

Note 1: Devices also available in 13" reel. Use suffix = SCX and SJX.

Note 2: Military grade device with environmental and burn-in processing. Use suffix = DMOB, FMOB and LMOB.

Logic Symbol

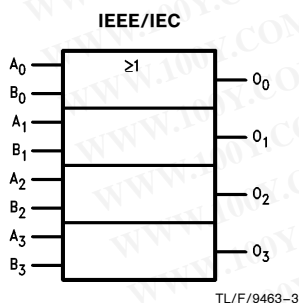

Connection Diagrams

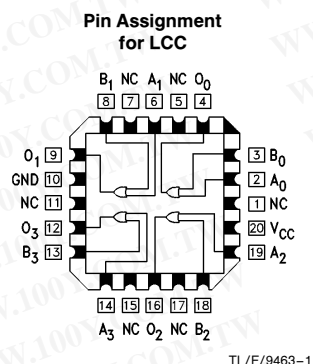
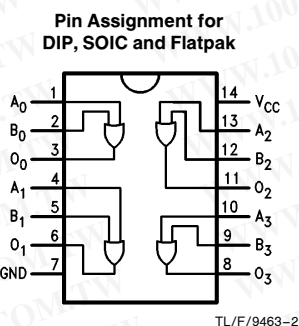

Unit Loading/Fan Out

Pin Names	Description	54F/74F	
		U.L. HIGH/LOW	Input I _{IH} /I _{IL} Output I _{OH} /I _{OL}
A _n , B _n	Inputs	1.0/1.0	20 μA / -0.6 mA
O _n	Outputs	50/33.3	-1 mA / 20 mA

TRI-STATE® is a registered trademark of National Semiconductor Corporation.

Absolute Maximum Ratings (Note 1)

If Military/Aerospace specified devices are required, please contact the National Semiconductor Sales Office/Distributors for availability and specifications.

Storage Temperature	-65°C to +150°C
Ambient Temperature under Bias	-55°C to +125°C
Junction Temperature under Bias	-55°C to +175°C
Plastic	-55°C to +150°C
V _{CC} Pin Potential to Ground Pin	-0.5V to +7.0V
Input Voltage (Note 2)	-0.5V to +7.0V
Input Current (Note 2)	-30 mA to +5.0 mA
Voltage Applied to Output in HIGH State (with V _{CC} = 0V)	
Standard Output	-0.5V to V _{CC}
TRI-STATE® Output	-0.5V to +5.5V
Current Applied to Output in LOW State (Max)	twice the rated I _{OL} (mA)
ESD Last Passing Voltage (Min)	4000V

Note 1: Absolute maximum ratings are values beyond which the device may be damaged or have its useful life impaired. Functional operation under these conditions is not implied.

Note 2: Either voltage limit or current limit is sufficient to protect inputs.

Recommended Operating Conditions

Free Air Ambient Temperature	
Military	-55°C to +125°C
Commercial	0°C to +70°C
Supply Voltage	
Military	+4.5V to +5.5V
Commercial	+4.5V to +5.5V

DC Electrical Characteristics

Symbol	Parameter	54F/74F			Units	V _{CC}	Conditions	
		Min	Typ	Max				
V _{IH}	Input HIGH Voltage	2.0			V		Recognized as a HIGH Signal	
V _{IL}	Input LOW Voltage				V		Recognized as a LOW Signal	
V _{CD}	Input Clamp Diode Voltage				V	Min	I _{IN} = -18 mA	
V _{OH}	Output HIGH Voltage	54F 10% V _{CC} 74F 10% V _{CC} 74F 5% V _{CC}	2.5 2.5 2.7			V	Min	I _{OH} = -1 mA I _{OH} = -1 mA I _{OH} = -1 mA
V _{OL}	Output LOW Voltage	54F 10% V _{CC} 74F 10% V _{CC}	0.5 0.5		V	Min	I _{OL} = 20 mA I _{OL} = 20 mA	
I _{IH}	Input HIGH Current	54F 74F	20.0 5.0		μA	Max	V _{IN} = 2.7V	
I _{BVI}	Input HIGH Current Breakdown Test	54F 74F	100 7.0		μA	Max	V _{IN} = 7.0V	
I _{CEX}	Output HIGH Leakage Current	54F 74F	250 50		μA	Max	V _{OUT} = V _{CC}	
V _{ID}	Input Leakage Test	74F	4.75		V	0.0	I _{ID} = 1.9 μA All Other Pins Grounded	
I _{OD}	Output Leakage Circuit Current	74F	3.75		μA	0.0	V _{IOD} = 150 mV All Other Pins Grounded	
I _{IL}	Input LOW Current				mA	Max	V _{IN} = 0.5V	
I _{OS}	Output Short-Circuit Current	-60			mA	Max	V _{OUT} = 0V	
I _{CCH}	Power Supply Current	6.1			mA	Max	V _O = HIGH	
I _{CCL}	Power Supply Current	10.3			mA	Max	V _O = LOW	

AC Electrical Characteristics

Symbol	Parameter	74F			54F		74F		Units
		T _A = +25°C V _{CC} = +5.0V C _L = 50 pF			T _A , V _{CC} = Mil C _L = 50 pF		T _A , V _{CC} = Com C _L = 50 pF		
		Min	Typ	Max	Min	Max	Min	Max	
t _{PLH}	Propagation Delay	3.0	4.2	5.6	3.0	7.5	3.0	6.6	ns
t _{PHL}	A _n , B _n to O _n	3.0	4.0	5.3	2.5	7.5	3.0	6.3	

Ordering Information

The device number is used to form part of a simplified purchasing code where the package type and temperature range are defined as follows:

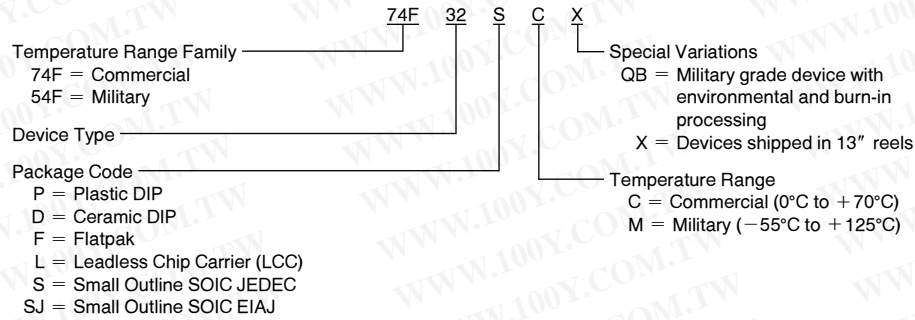

Physical Dimensions inches (millimeters)

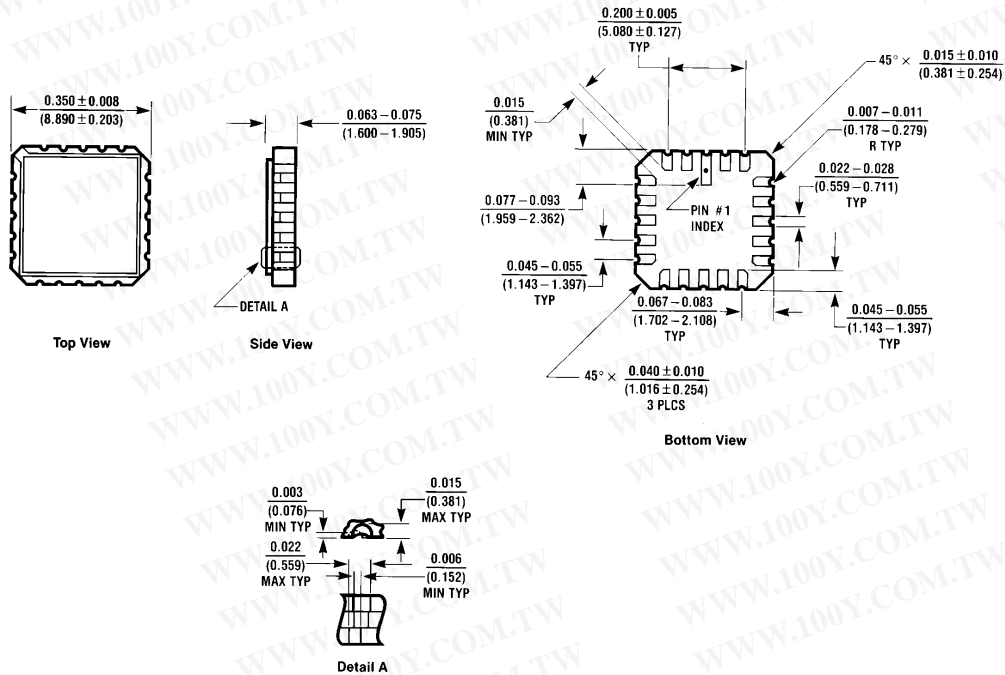

20-Lead Ceramic Leadless Chip Carrier (L)
NS Package Number E20A

E20A (REV D)

Physical Dimensions inches (millimeters) (Continued)

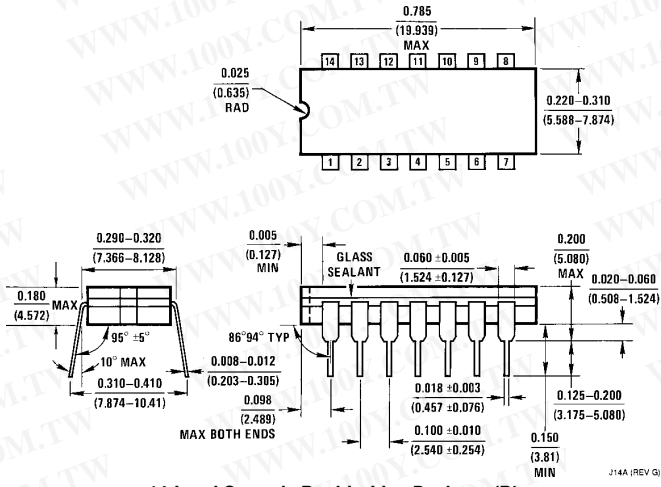

**14-Lead Ceramic Dual-In-Line Package (D)
NS Package Number J14A**

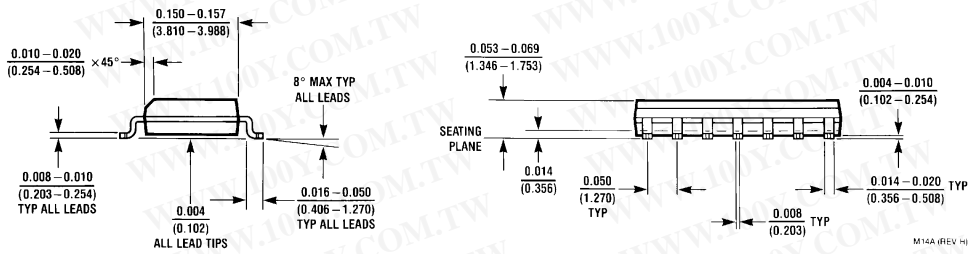
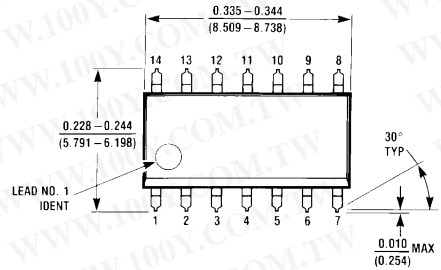

**14-Lead (0.150" Wide) Molded Small Outline Package, JEDEC (S)
NS Package Number M14A**

Physical Dimensions inches (millimeters) (Continued)

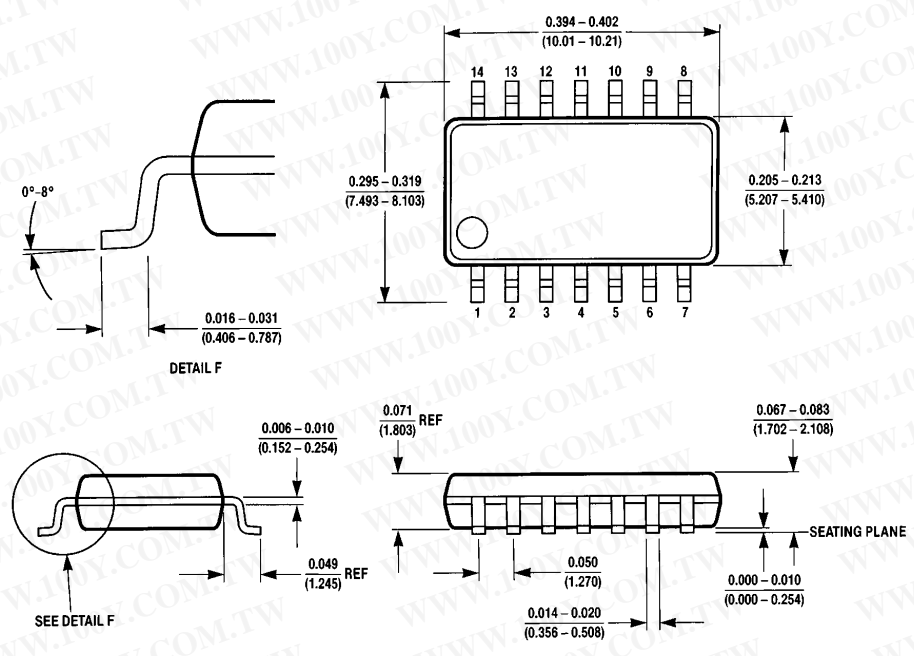

**14-Lead (0.300" Wide) Molded Small Outline Package, EIAJ (SJ)
NS Package Number M14D**

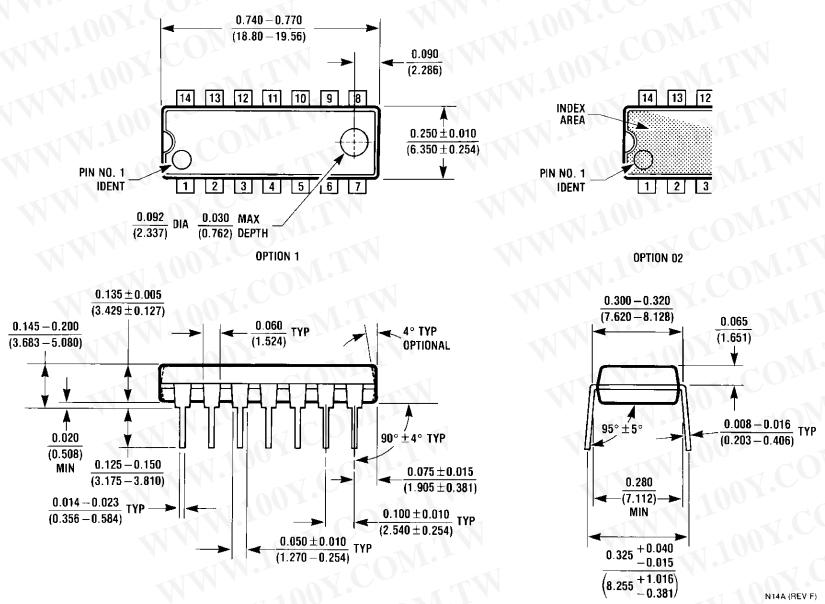

**14-Lead (0.300" Wide) Molded Dual-In-Line Package (P)
NS Package Number N14A**

WWW.100Y.COM.TW

54F/74F32 Quad 2-Input OR Gate

Physical Dimensions inches (millimeters) (Continued)

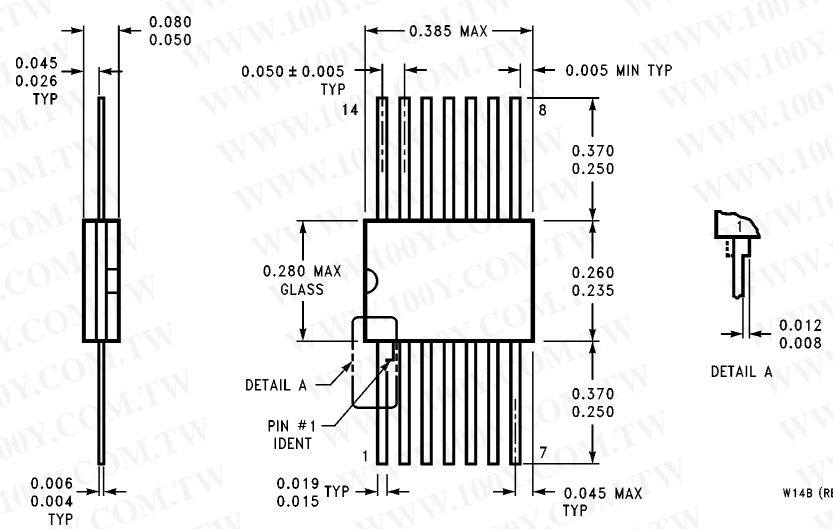

14-Lead Ceramic Flatpak (F)
NS Package Number W14B

W14B (REV J)

LIFE SUPPORT POLICY

NATIONAL'S PRODUCTS ARE NOT AUTHORIZED FOR USE AS CRITICAL COMPONENTS IN LIFE SUPPORT DEVICES OR SYSTEMS WITHOUT THE EXPRESS WRITTEN APPROVAL OF THE PRESIDENT OF NATIONAL SEMICONDUCTOR CORPORATION. As used herein:

1. Life support devices or systems are devices or systems which, (a) are intended for surgical implant into the body, or (b) support or sustain life, and whose failure to perform, when properly used in accordance with instructions for use provided in the labeling, can be reasonably expected to result in a significant injury to the user.
2. A critical component is any component of a life support device or system whose failure to perform can be reasonably expected to cause the failure of the life support device or system, or to affect its safety or effectiveness.

