

DATA SHEET

勝特力材料 886-3-5753170
勝特力电子(上海) 86-21-54151736
勝特力电子(深圳) 86-755-83298787
[Http://www.100y.com.tw](http://www.100y.com.tw)

74LVC273

Octal D-type flip-flop with reset;
positive-edge trigger

Product specification
Supersedes data of 1998 May 20

2003 Oct 30

Octal D-type flip-flop with reset; positive-edge trigger

74LVC273

FEATURES

- Wide supply voltage range from 1.2 to 3.6 V
- Inputs accept voltages up to 5.5 V
- CMOS low power consumption
- Direct interface with TTL levels
- Output drive capability 50 Ω transmission lines at 85 °C
- Complies with JEDEC standard no. 8-1A
- ESD protection:
HBM EIA/JESD22-A114-A exceeds 2000 V
MM EIA/JESD22-A115-A exceeds 200 V.
- Specified from -40 to +85 °C.

DESCRIPTION

The 74LVC273 is a low-voltage Si-gate CMOS device, superior to most advanced CMOS compatible TTL families.

The 74LVC273 has eight edge-triggered, D-type flip-flops with individual D inputs and Q outputs. The common clock (CP) and master reset (\overline{MR}) inputs load and reset (clear) all flip-flops simultaneously. The state of each D input, one set-up time before the LOW-to-HIGH clock transition, is transferred to the corresponding output (Qn) of the flip-flop.

All outputs will be forced LOW independently of clock or data inputs by a LOW voltage level on the \overline{MR} input.

The device is useful for applications where the true output only is required and the clock and master reset are common to all storage elements.

QUICK REFERENCE DATA

GND = 0 V; $T_{amb} = 25\text{ °C}$; $t_r = t_f \leq 2.5\text{ ns}$.

SYMBOL	PARAMETER	CONDITIONS	TYPICAL	UNIT
t_{PHL}/t_{PLH}	propagation delay CP to Qn	$C_L = 50\text{ pF}$; $V_{CC} = 3.3\text{ V}$	6.0	ns
	propagation delay \overline{MR} to Qn	$C_L = 50\text{ pF}$; $V_{CC} = 3.3\text{ V}$	6.3	ns
f_{max}	maximum clock frequency		230	MHz
C_I	input capacitance		5.0	pF
C_{PD}	power dissipation capacitance per flip-flop	outputs disabled; notes 1 and 2	22	pF

Notes

1. C_{PD} is used to determine the dynamic power dissipation (P_D in μW)

$$P_D = C_{PD} \times V_{CC}^2 \times f_i \times N + \Sigma(C_L \times V_{CC}^2 \times f_o) \text{ where:}$$

f_i = input frequency in MHz;

f_o = output frequency in MHz;

C_L = output load capacitance in pF;

V_{CC} = supply voltage in Volts;

N = total load switching outputs;

$\Sigma(C_L \times V_{CC}^2 \times f_o)$ = sum of the outputs.

2. The definition is $V_I = \text{GND}$ to V_{CC} .

Octal D-type flip-flop with reset;
 positive-edge trigger

74LVC273

FUNCTION TABLE

See note 1.

OPERATING MODES	INPUT			OUTPUT
	MR	CP	Dn	Qn
Reset (clear)	L	X	X	L
Load '1'	H	↑	h	H
Load '0'	H	↑	l	L

Note

- H = HIGH voltage level;
 h = HIGH voltage level one set-up time prior to the HIGH-to-LOW CP transition;
 L = LOW voltage level;
 l = LOW voltage level one set-up time prior to the HIGH-to-LOW CP transition;
 ↑ = LOW-to-HIGH transition;
 X = don't care.

ORDERING INFORMATION

TYPE NUMBER	PACKAGE				
	TEMPERATURE RANGE	PINS	PACKAGE	MATERIAL	CODE
74LVC273D	-40 to +85 °C	20	SO20	plastic	SOT163-1
74LVC273DB	-40 to +85 °C	20	SSOP20	plastic	SOT339-1
74LVC273PW	-40 to +85 °C	20	TSSOP20	plastic	SOT360-1
74LVC273BQ	-40 to +85 °C	20	DHVQFN20	plastic	SOT764-1

PINNING

PIN	SYMBOL	DESCRIPTION
1	MR	master reset input (active LOW)
2	Q0	flip-flop output
3	D0	data input
4	D1	data input
5	Q1	flip-flop output
6	Q2	flip-flop output
7	D2	data input
8	D3	data input
9	Q3	flip-flop output
10	GND	ground (0 V)

PIN	SYMBOL	DESCRIPTION
11	CP	clock input (LOW-to-HIGH, edge-triggered)
12	Q4	flip-flop output
13	D4	data input
14	D4	data input
15	Q5	flip-flop output
16	Q6	flip-flop output
17	D6	data input
18	D7	data input
19	Q7	flip-flop output
20	V _{CC}	supply voltage

Octal D-type flip-flop with reset;
 positive-edge trigger

74LVC273

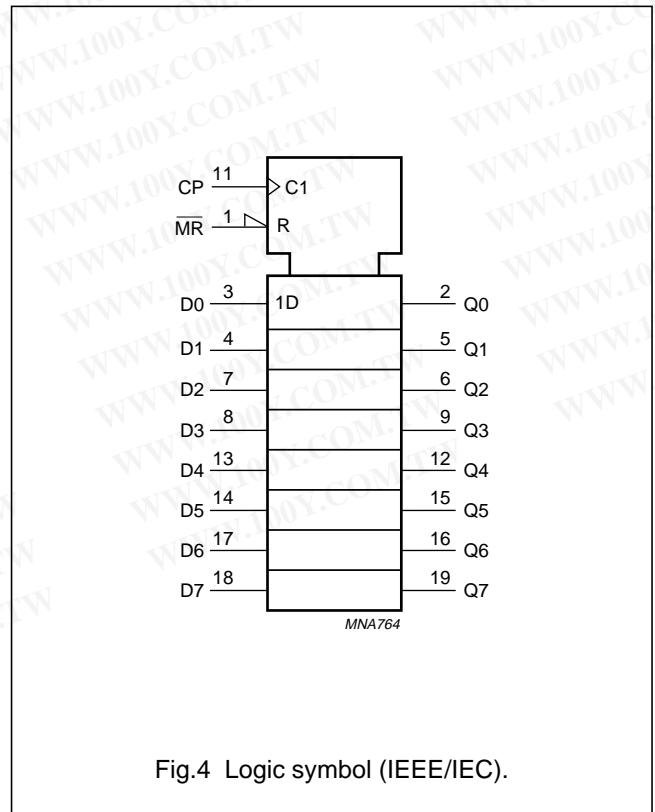
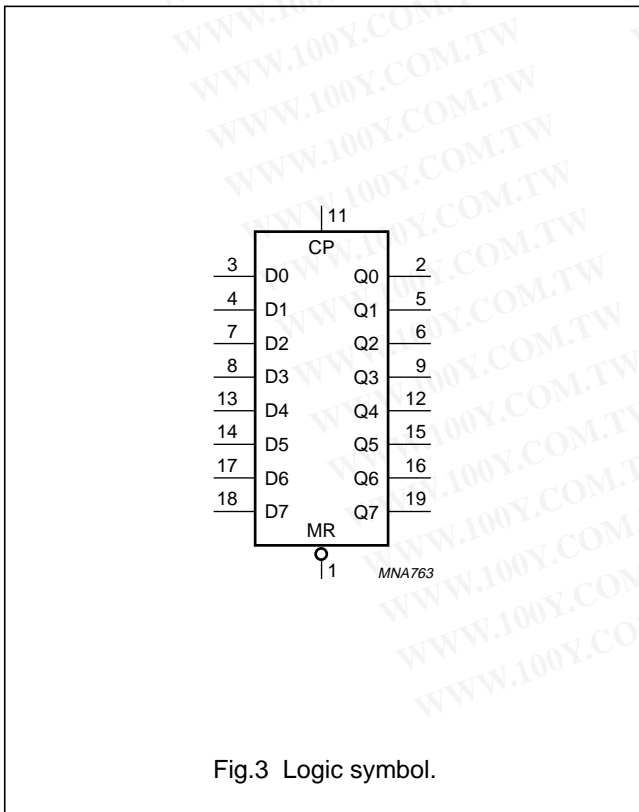
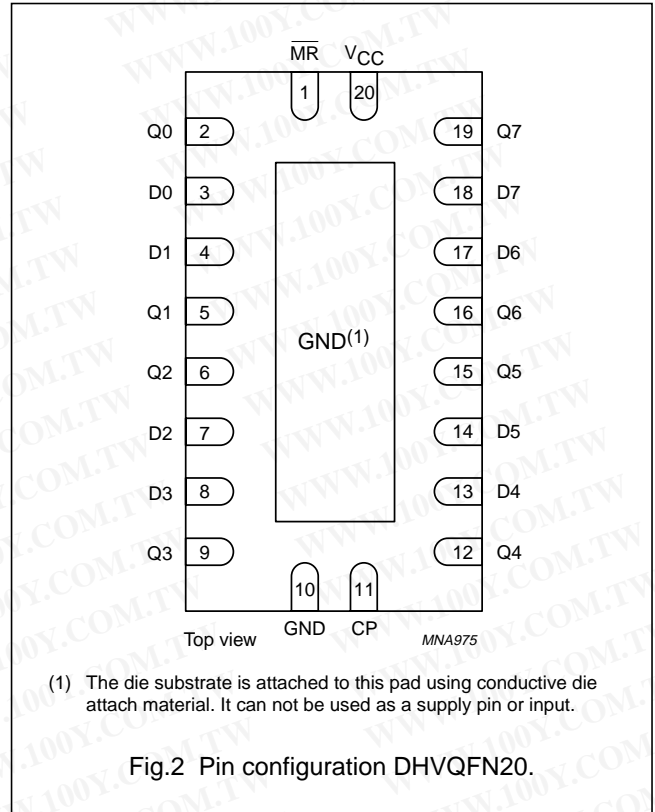
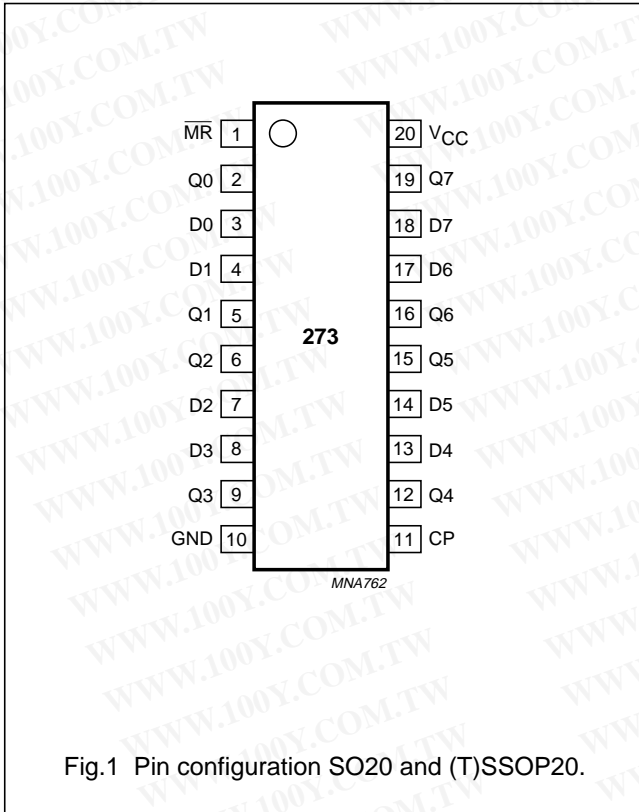

Octal D-type flip-flop with reset;
 positive-edge trigger

74LVC273

RECOMMENDED OPERATING CONDITIONS

SYMBOL	PARAMETER	CONDITIONS	MIN.	MAX.	UNIT
V _{CC}	supply voltage	maximum speed performance	2.7	3.6	V
		low-voltage applications	1.2	3.6	V
V _I	input voltage		0	5.5	V
V _O	output voltage		0	V _{CC}	V
T _{amb}	operating ambient temperature	in free air	-40	+85	°C
t _r , t _f	input rise and fall times	V _{CC} = 1.2 to 2.7 V	0	20	ns/V
		V _{CC} = 2.7 to 3.6 V	0	10	ns/V

LIMITING VALUES

In accordance with the Absolute Maximum Rating System (IEC 60134); voltages are referenced to GND (ground = 0 V).

SYMBOL	PARAMETER	CONDITIONS	MIN.	MAX.	UNIT
V _{CC}	supply voltage		-0.5	+6.5	V
I _{IK}	input diode current	V _I < 0	-	-50	mA
V _I	input voltage	note 1	-0.5	+5.5	V
I _{OK}	output diode current	V _O > V _{CC} or V _O < 0	-	50	mA
V _O	output voltage	note 1	-0.5	V _{CC} + 0.5	V
I _O	output source or sink current	V _O = 0 to V _{CC}	-	±50	mA
I _{CC} , I _{GND}	V _{CC} or GND current		-	±100	mA
T _{stg}	storage temperature		-65	+150	°C
P _{tot}	power dissipation per package	T _{amb} = -40 to +85 °C; note 2	-	500	mW

Notes

- The input and output voltage ratings may be exceeded if the input and output current ratings are observed.
- For SO20 packages: above 70 °C derate linearly with 8 mW/K.
 For SSOP20 and TSSOP20 packages: above 60 °C derate linearly with 5.5 mW/K.
 For DHVQFN20 packages: above 60 °C derate linearly with 4.5 mW/K.

Octal D-type flip-flop with reset;
 positive-edge trigger

74LVC273

DC CHARACTERISTICS

At recommended operating conditions; voltages are referenced to GND (ground = 0 V).

SYMBOL	PARAMETER	TEST CONDITIONS		MIN.	TYP. ⁽¹⁾	MAX.	UNIT
		OTHER	V _{CC} (V)				
T_{amb} = -40 to +85 °C							
V _{IH}	HIGH-level input voltage		1.2	V _{CC}	-	-	V
			2.7 to 3.6	2.0	-	-	V
V _{IL}	LOW-level input voltage		1.2	-	-	GND	V
			2.7 to 3.6	-	-	0.8	V
V _{OH}	HIGH-level output voltage	V _I = V _{IH} or V _{IL}	2.7	V _{CC} - 0.5	-	-	V
		I _O = -12 mA	3.0	V _{CC} - 0.2	V _{CC}	-	V
		I _O = -100 μA	3.0	V _{CC} - 0.6	-	-	V
		I _O = -24 mA	3.0	V _{CC} - 1.0	-	-	V
V _{OL}	LOW-level output voltage	V _I = V _{IH} or V _{IL}	2.7	-	-	0.40	V
		I _O = 12 mA	3.0	-	-	0.20	V
		I _O = 24 mA	3.0	-	-	0.55	V
I _{LI}	input leakage current	V _I = 5.5 V or GND	3.6	-	±0.1	±5	μA
I _{oz}	3-state output OFF-state current	V _I = V _{IH} or V _{IL} ; V _O = V _{CC} or GND	3.6	-	0.1	±10	μA
I _{CC}	quiescent supply current	V _I = V _{CC} or GND; I _O = 0	3.6	-	0.1	10	μA
ΔI _{CC}	additional supply current per input pin	V _I = V _{CC} - 0.6 V; I _O = 0	2.7 to 3.6	-	5	500	μA

Note

1. All typical values are measured at V_{CC} = 3.3 V and T_{amb} = 25 °C.

Octal D-type flip-flop with reset;
 positive-edge trigger

74LVC273

AC CHARACTERISTICS

GND = 0 V; $t_r = t_f = 2.5$ ns; $C_L = 50$ pF; $R_L = 500$ Ω .

SYMBOL	PARAMETER	TEST CONDITIONS		MIN.	TYP.	MAX.	UNIT
		WAVEFORMS	V _{CC} (V)				
T_{amb} = -40 to +85 °C							
t _{PLH} /t _{PHL}	propagation delay CP to Qn	see Fig.5	2.7	–	6.6	11.2	ns
			3.0 to 3.6	–	6.0 ⁽¹⁾	10.2	ns
t _{PHL}	propagation delay \overline{MR} to Qn	see Fig.6	2.7	–	7.4	12.0	ns
			3.0 to 3.6	–	6.3 ⁽¹⁾	11.0	ns
t _W	clock pulse width HIGH or LOW	see Fig.5	2.7	5	1.8	–	ns
			3.0 to 3.6	4	1.2 ⁽¹⁾	–	ns
t _W	master reset pulse width LOW	see Fig.6	2.7	5	1.7	–	ns
			3.0 to 3.6	4	1.2 ⁽¹⁾	–	ns
t _{rem}	removal time \overline{MR} to CP	see Fig.6	2.7	+3	–1.0	–	ns
			3.0 to 3.6	+2	–1.0 ⁽¹⁾	–	ns
t _{su}	set-up time Dn to CP	see Fig.7	2.7	3	1.0	–	ns
			3.0 to 3.6	2	0.7 ⁽¹⁾	–	ns
t _h	hold time Dn to CP	see Fig.7	2.7	0	–0.9	–	ns
			3.0 to 3.6	0	–0.6 ⁽¹⁾	–	ns
f _{max}	maximum clock frequency	see Fig.5	2.7	100	–	–	MHz
			3.0 to 3.6	125	230 ⁽¹⁾	–	MHz

Note

1. Typical values are measured at V_{CC} = 3.3 V and T_{amb} = 25 °C.

Octal D-type flip-flop with reset;
 positive-edge trigger

74LVC273

AC WAVEFORMS

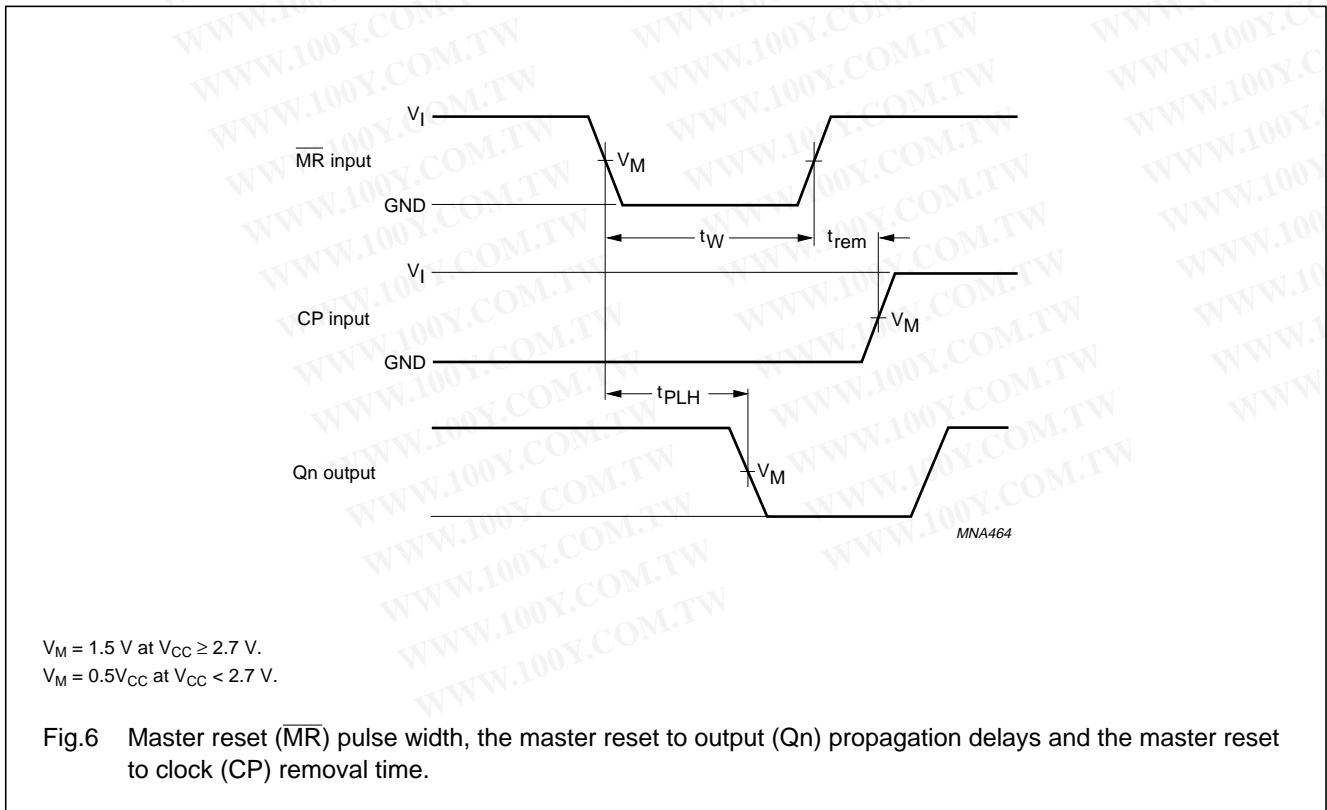
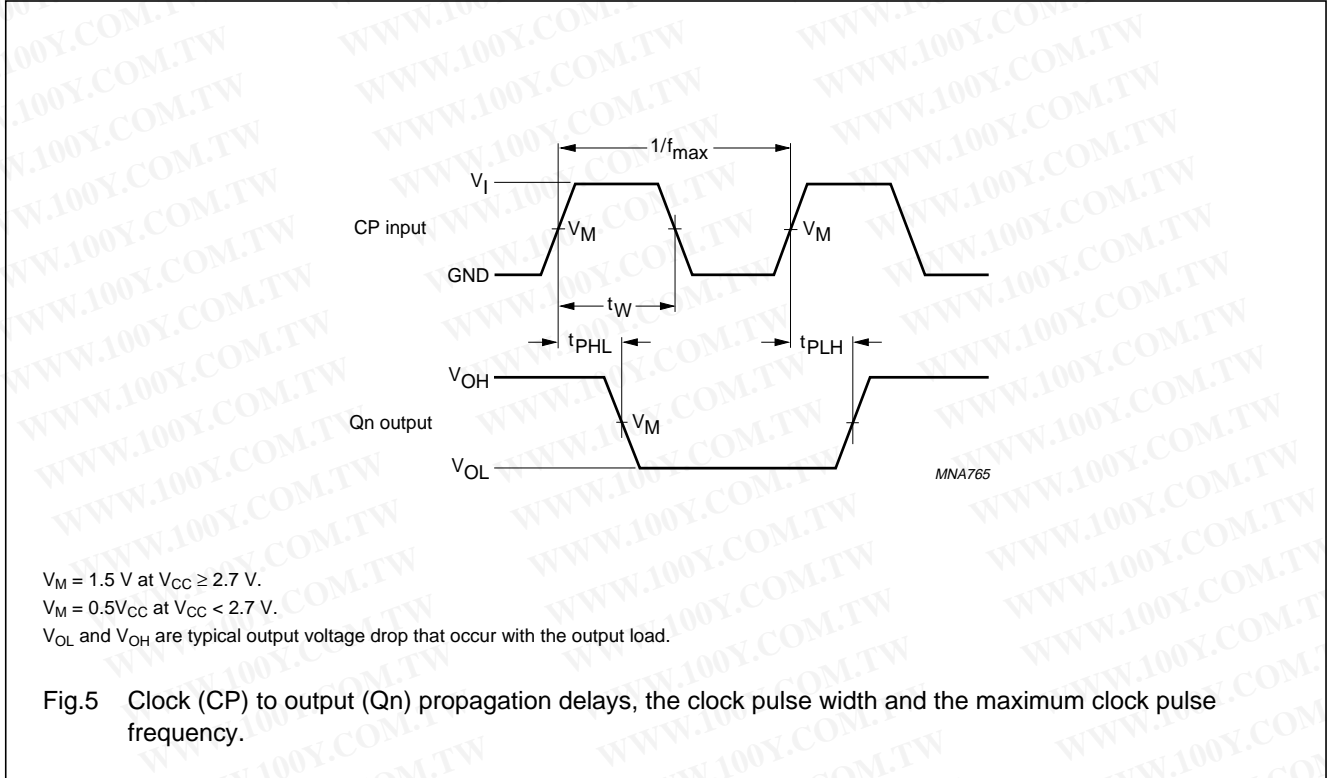

Octal D-type flip-flop with reset;
positive-edge trigger

74LVC273

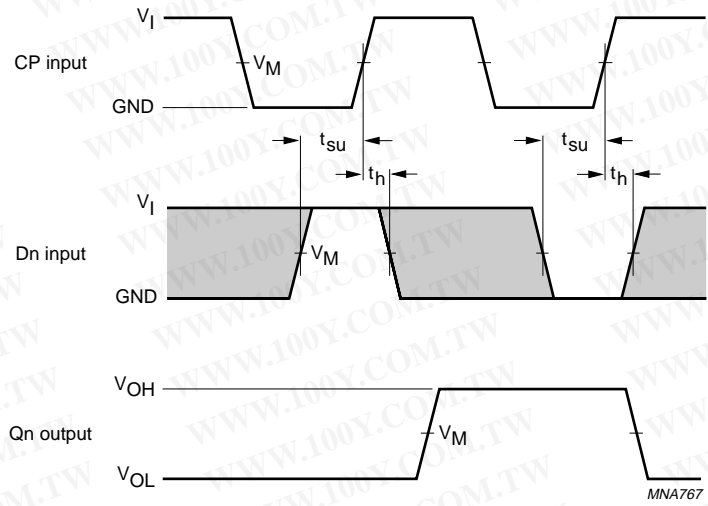

$V_M = 1.5 \text{ V}$ at $V_{CC} \geq 2.7 \text{ V}$.
 $V_M = 0.5V_{CC}$ at $V_{CC} < 2.7 \text{ V}$.

V_{OL} and V_{OH} are typical output voltage drop that occur with the output load.

The shaded areas indicate when the input is permitted to change for predictable output performance.

Fig.7 Data set-up and hold times for the data input (Dn).

Octal D-type flip-flop with reset;
positive-edge trigger

74LVC273

TEST CIRCUIT

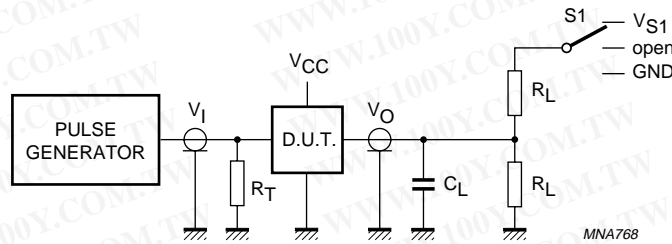
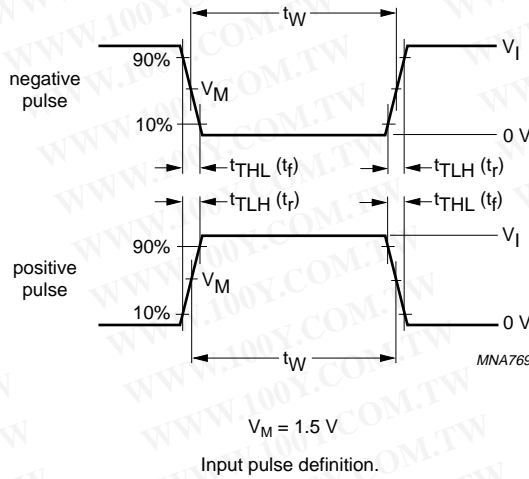

TEST	S1
t_{PLH}/t_{PHL}	open
t_{PLZ}/t_{PZL}	V_{S1}
t_{PHZ}/t_{PZH}	GND

V_{CC}	V_I	V_{S1}
$< 2.7\text{ V}$	V_{CC}	$2 \times V_{CC}$
$2.7\text{ to }3.6\text{ V}$	2.7 V	$2 \times V_{CC}$

Definitions for test circuits:

R_L = Load resistor.

C_L = Load capacitance including jig and probe capacitance.

R_T = Termination resistance should be equal to the output impedance Z_o of the pulse generator.

Fig.8 Load circuitry for switching times.

Octal D-type flip-flop with reset;
 positive-edge trigger

74LVC273

PACKAGE OUTLINES

SO20: plastic small outline package; 20 leads; body width 7.5 mm

SOT163-1

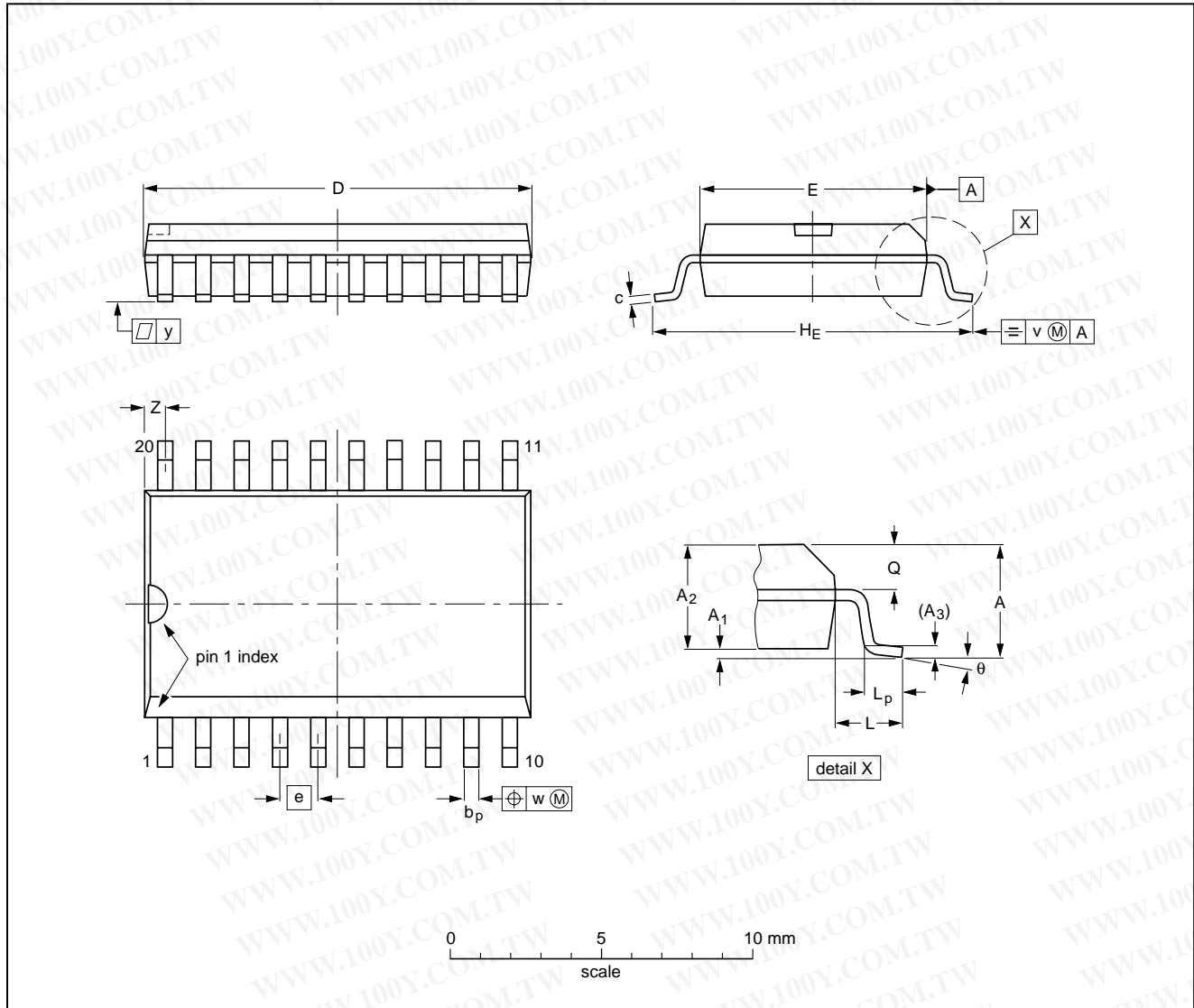

DIMENSIONS (inch dimensions are derived from the original mm dimensions)

UNIT	A max.	A ₁	A ₂	A ₃	b _p	c	D ⁽¹⁾	E ⁽¹⁾	e	H _E	L	L _p	Q	v	w	y	z ⁽¹⁾	θ
mm	2.65	0.3 0.1	2.45 2.25	0.25	0.49 0.36	0.32 0.23	13.0 12.6	7.6 7.4	1.27	10.65 10.00	1.4	1.1 0.4	1.1 1.0	0.25	0.25	0.1	0.9 0.4	8° 0°
inches	0.1	0.012 0.004	0.096 0.089	0.01	0.019 0.014	0.013 0.009	0.51 0.49	0.30 0.29	0.05	0.419 0.394	0.055	0.043 0.016	0.043 0.039	0.01	0.01	0.004	0.035 0.016	

Note

1. Plastic or metal protrusions of 0.15 mm (0.006 inch) maximum per side are not included.

OUTLINE VERSION	REFERENCES				EUROPEAN PROJECTION	ISSUE DATE
	IEC	JEDEC	JEITA			
SOT163-1	075E04	MS-013				99-12-27 03-02-19

Octal D-type flip-flop with reset;
 positive-edge trigger

74LVC273

SSOP20: plastic shrink small outline package; 20 leads; body width 5.3 mm

SOT339-1

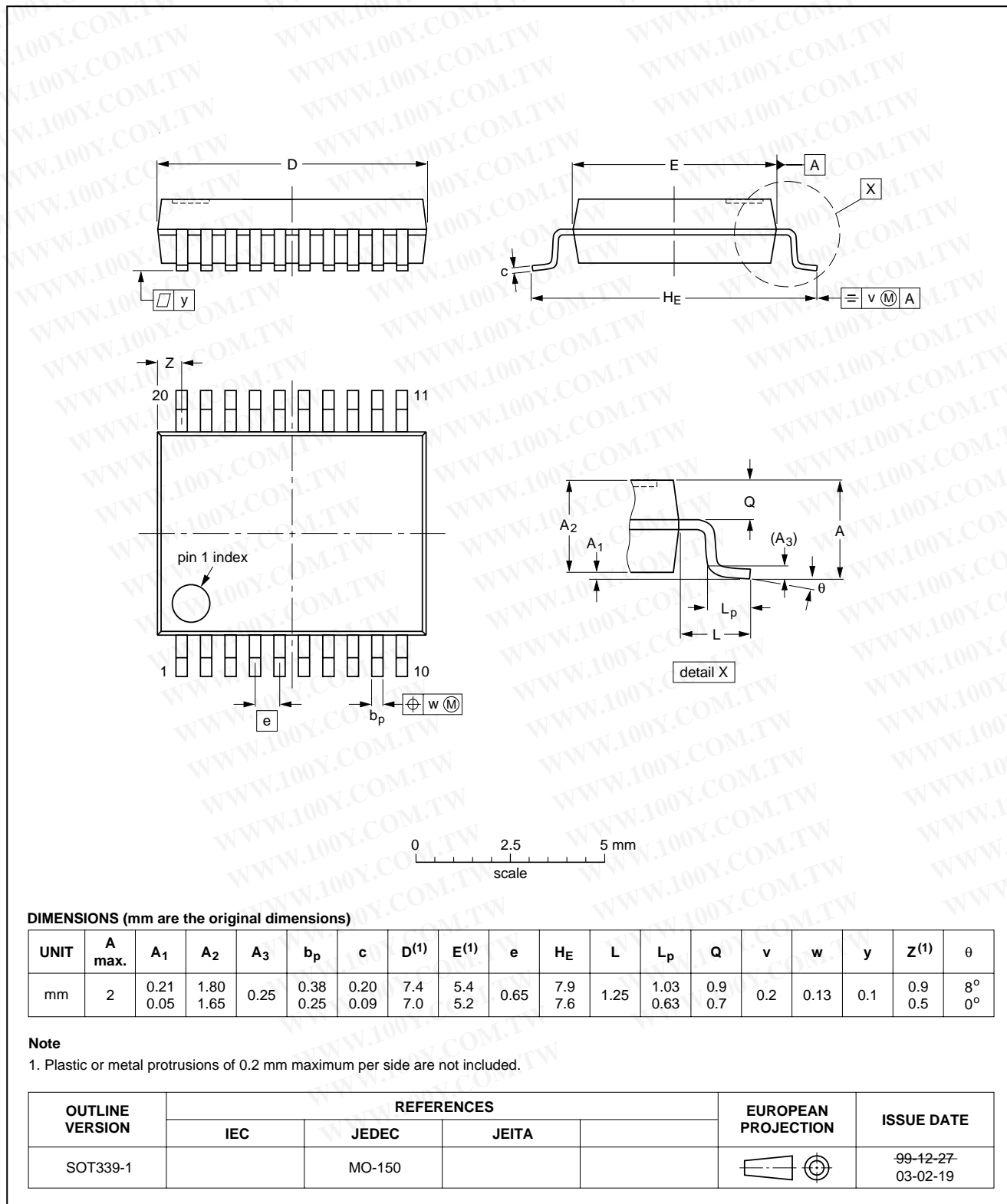

Octal D-type flip-flop with reset;
positive-edge trigger

74LVC273

TSSOP20: plastic thin shrink small outline package; 20 leads; body width 4.4 mm

SOT360-1

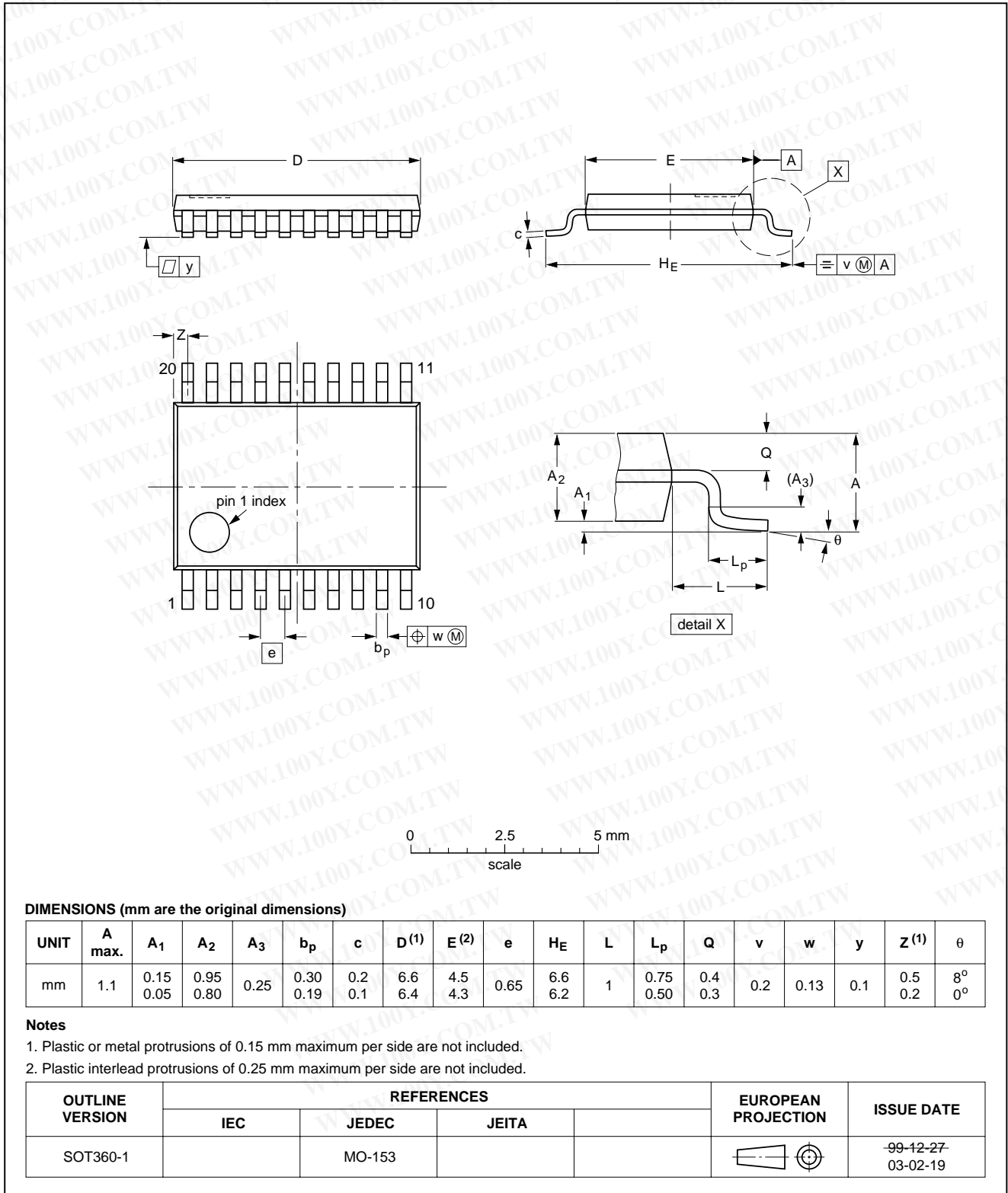

Octal D-type flip-flop with reset;
positive-edge trigger

74LVC273

DHVQFN20: plastic dual in-line compatible thermal enhanced very thin quad flat package; no leads;
20 terminals; body 2.5 x 4.5 x 0.85 mm

SOT764-1

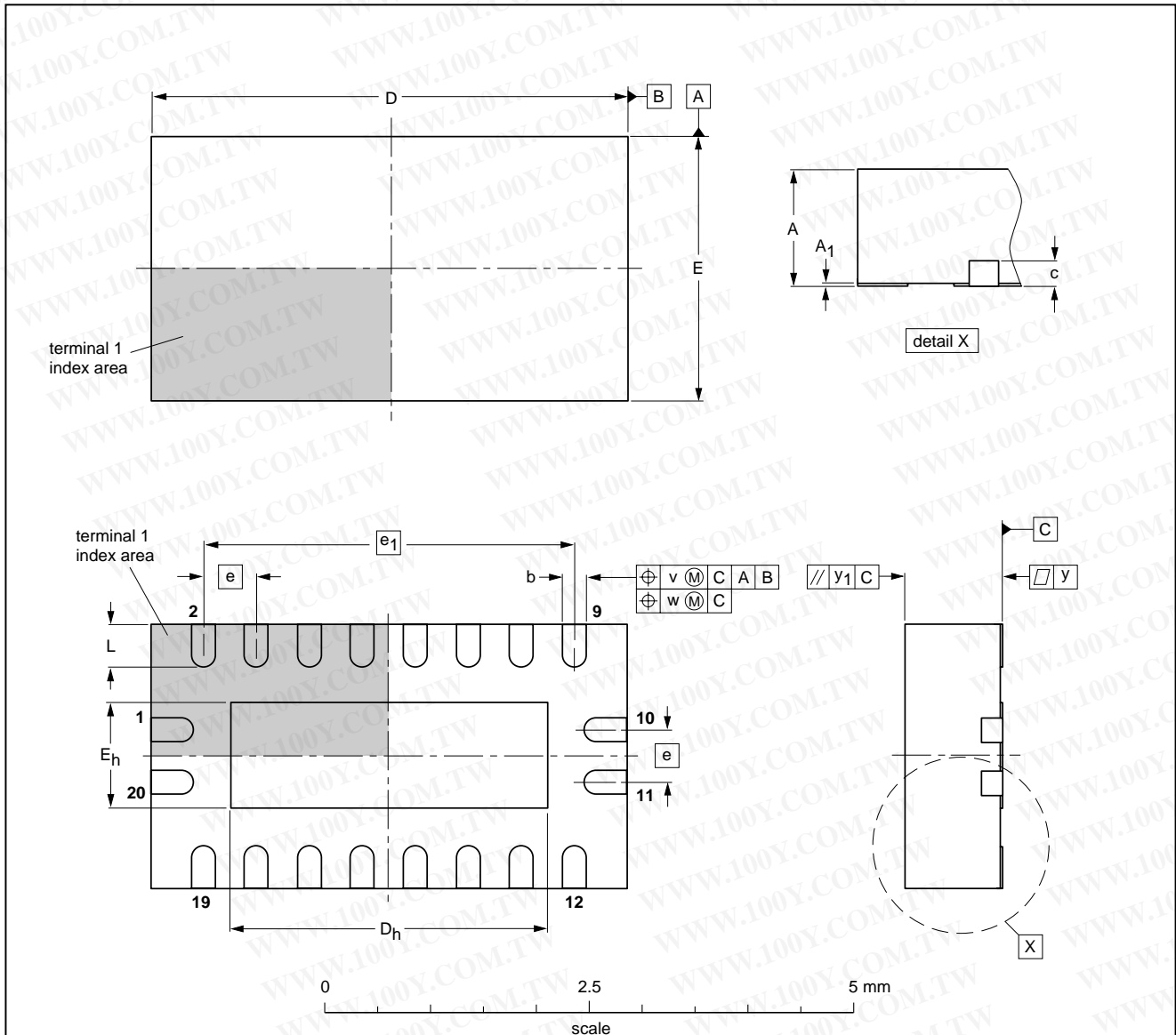

DIMENSIONS (mm are the original dimensions)

UNIT	A ⁽¹⁾ max.	A ₁	b	c	D ⁽¹⁾	D _h	E ⁽¹⁾	E _h	e	e ₁	L	v	w	y	y ₁
mm	1	0.05 0.00	0.30 0.18	0.2	4.6 4.4	3.15 2.85	2.6 2.4	1.15 0.85	0.5	3.5	0.5 0.3	0.1	0.05	0.05	0.1

Note

1. Plastic or metal protrusions of 0.075 mm maximum per side are not included.

OUTLINE VERSION	REFERENCES				EUROPEAN PROJECTION	ISSUE DATE
	IEC	JEDEC	JEITA			
SOT764-1	---	MO-241	---			02-10-17 03-01-27

Octal D-type flip-flop with reset;
 positive-edge trigger

74LVC273

DATA SHEET STATUS

LEVEL	DATA SHEET STATUS ⁽¹⁾	PRODUCT STATUS ⁽²⁾⁽³⁾	DEFINITION
I	Objective data	Development	This data sheet contains data from the objective specification for product development. Philips Semiconductors reserves the right to change the specification in any manner without notice.
II	Preliminary data	Qualification	This data sheet contains data from the preliminary specification. Supplementary data will be published at a later date. Philips Semiconductors reserves the right to change the specification without notice, in order to improve the design and supply the best possible product.
III	Product data	Production	This data sheet contains data from the product specification. Philips Semiconductors reserves the right to make changes at any time in order to improve the design, manufacturing and supply. Relevant changes will be communicated via a Customer Product/Process Change Notification (CPCN).

Notes

1. Please consult the most recently issued data sheet before initiating or completing a design.
2. The product status of the device(s) described in this data sheet may have changed since this data sheet was published. The latest information is available on the Internet at URL <http://www.semiconductors.philips.com>.
3. For data sheets describing multiple type numbers, the highest-level product status determines the data sheet status.

DEFINITIONS

Short-form specification — The data in a short-form specification is extracted from a full data sheet with the same type number and title. For detailed information see the relevant data sheet or data handbook.

Limiting values definition — Limiting values given are in accordance with the Absolute Maximum Rating System (IEC 60134). Stress above one or more of the limiting values may cause permanent damage to the device. These are stress ratings only and operation of the device at these or at any other conditions above those given in the Characteristics sections of the specification is not implied. Exposure to limiting values for extended periods may affect device reliability.

Application information — Applications that are described herein for any of these products are for illustrative purposes only. Philips Semiconductors make no representation or warranty that such applications will be suitable for the specified use without further testing or modification.

DISCLAIMERS

Life support applications — These products are not designed for use in life support appliances, devices, or systems where malfunction of these products can reasonably be expected to result in personal injury. Philips Semiconductors customers using or selling these products for use in such applications do so at their own risk and agree to fully indemnify Philips Semiconductors for any damages resulting from such application.

Right to make changes — Philips Semiconductors reserves the right to make changes in the products - including circuits, standard cells, and/or software - described or contained herein in order to improve design and/or performance. When the product is in full production (status 'Production'), relevant changes will be communicated via a Customer Product/Process Change Notification (CPCN). Philips Semiconductors assumes no responsibility or liability for the use of any of these products, conveys no licence or title under any patent, copyright, or mask work right to these products, and makes no representations or warranties that these products are free from patent, copyright, or mask work right infringement, unless otherwise specified.