

勝特力材料 886-3-5753170  
 勝特力电子(上海) 86-21-34970699  
 勝特力电子(深圳) 86-755-83298787  
[Http://www.100y.com.tw](http://www.100y.com.tw)

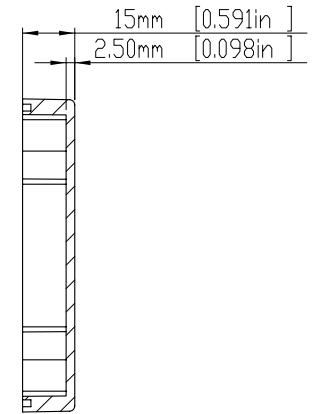
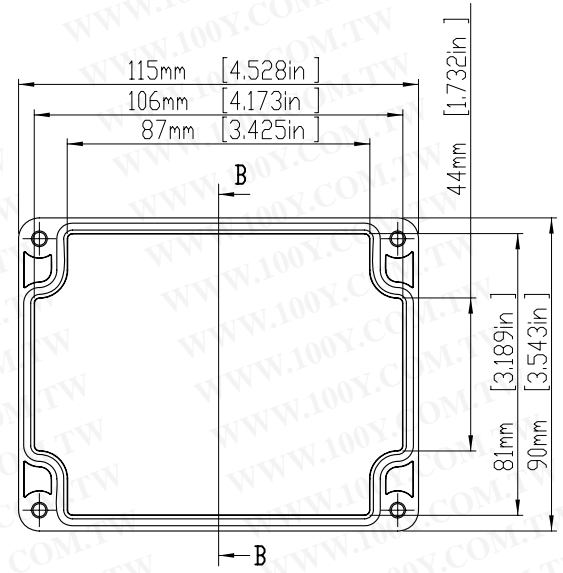
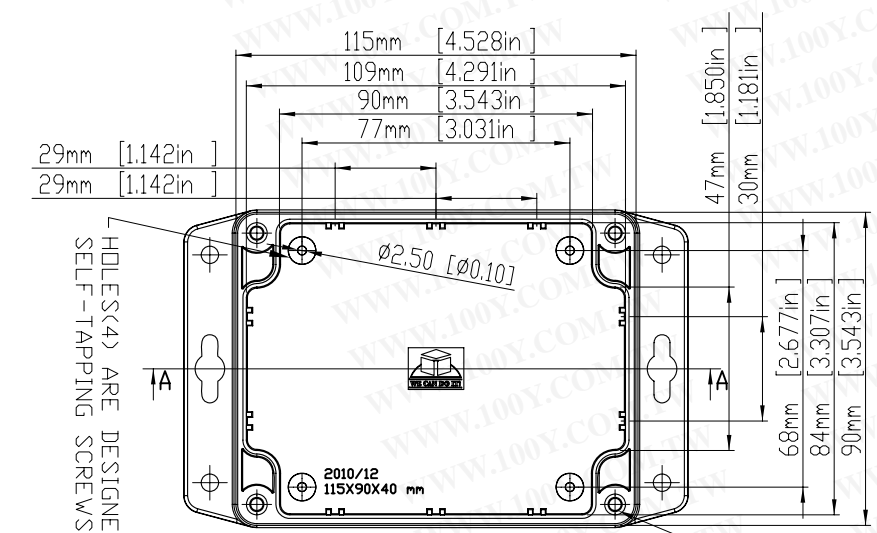

SECTION B-B  
SCALE 2 : 3

HOLE(S) ARE DESIGNED FOR SELF-TAPPING SCREWS USE.

Four(4) M4X20mm PAN HEAD SCREWS.

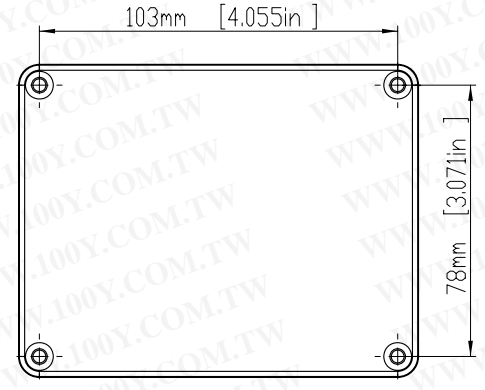
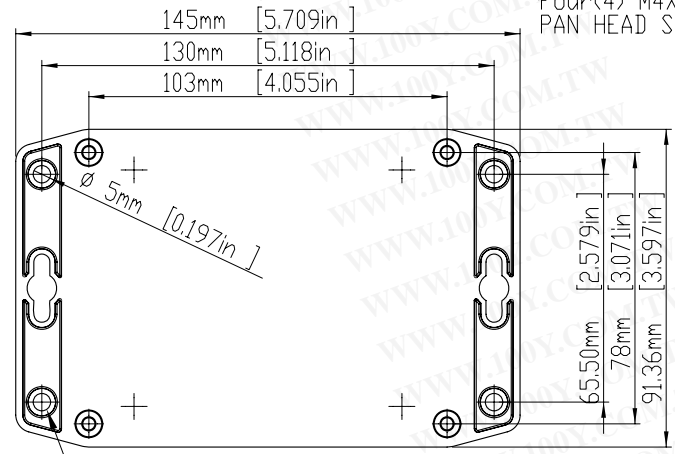

SECTION A-A  
SCALE 2 : 3

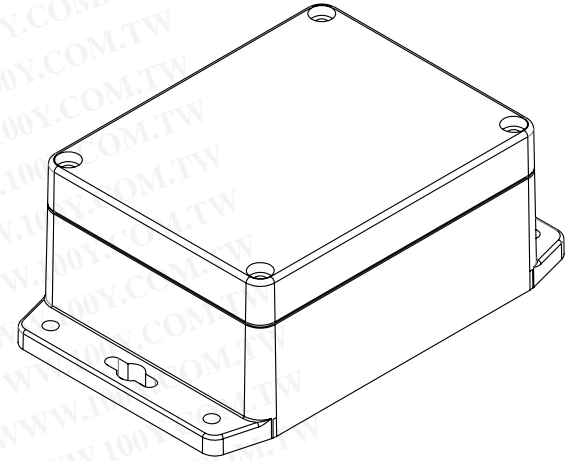
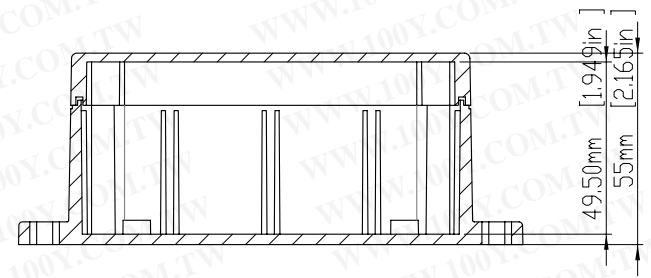

STOCK NO.	MATERIAL	BASE-COLOR	COVER-COLOR
G212MF	POLYCARBONATE UL94-HB	LIGHT GRAY(RAL7035)	LIGHT GRAY(RAL7035)
G212CMF	POLYCARBONATE UL94-HB	LIGHT GRAY(RAL7035)	CLEAR
G311MF	ABS UL94-HB	DARK GRAY(RAL7000)	DARK GRAY(RAL7000)

勝特力材料 886-3-5753170  
勝特力电子(上海) 86-21-34970699  
勝特力电子(深圳) 86-755-83298787  
[Http://www.100y.com.tw](http://www.100y.com.tw)