

4-port 2-position direct-acting solenoid valve for vacuum and positive pressure

PCS/RCS241B spring return

PCL/RCL241C latch type solenoid



PCL/RCL241C incorporates newly developed one coil latch type solenoid !

Compact Double solenoid has been downsized to single solenoid.

Energy saving Energy-saving circuit is incorporated ; power consumption during holding is 0.5W.
No necessity for turning on power continuously to hold switching position.

Safety Detent mechanism to hold switching position with permanent magnet assures safety operations such as keeping attraction by vacuum.

Model change

PCL/RCL241B has been remodeled.

Quick response time

Quicker response time of 3ms than that of usual 2-coil latch type (5ms)

Compact

Cubic volume has been reduced by 20% as compared with that of KURODA's usual 2-coil latch type.

Vacuum usable Wide range from vacuum to 0.8MPa

Rational construction with direct-acting poppet valve realizes wide range of use covering from low vacuum of -0.1MPa to 0.8MPa , and this valve also be used as pneumatic solenoid valve and vacuum switching valve.

Clean and oil-free

Usable in clean environment owing to direct-acting type without pilot exhaust and breathing hole.
Ozone-proof rubber material is used as standard item.
Oil-free type is also available upon order.



LATCHING SOLENOID VALVE/INDIVIDUAL INSTRUCTIONS

Be sure to read them before use.

Also refer to Par. "For Safety Use" and common instructions.

RELATION BETWEEN INPUT ELECTRIC SIGNAL AND VALVE OUTPUT

CAUTION

- Relation between input electric signal and valve output is as follows :

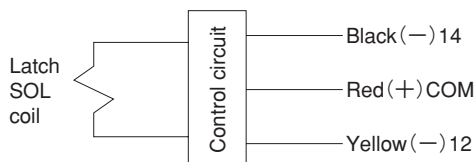

<Power supply and connection of solenoid valve>

- ① Power is supplied to red (+) lead wire and yellow (-) lead wire.

VA01PL□23 : Port 1 closes

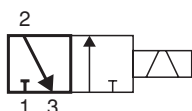

PCL/RCL241 : Port 1→2、4→3/5

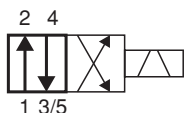

- ② Power is supplied to red (+) lead wire and black (-) lead wire.

VA01PL□23 : Port 1→2

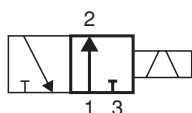

PCL/RCL241 : Port 1→4、2→3/5

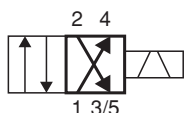

CONTINUOUS SUPPLY OF POWER

CAUTION

- Latch type solenoid valve requires no continuous supply of power.

After switching by pulse signal, that position is held until reverse direction signal is input. However, set input signal at minimum required excitation time (0.05ms) or over.

OPERATING PRINCIPLE OF LATCH TYPE SOLENOID VALVE

- Supplying power to Control Circuit 12

When turning on Contact A and supplying power to Control Circuit 12, force FA is generated to separate the movable iron core from the fixed iron core.

Force to which spring force f is added exceeds the attractive force FM of the permanent magnet, thereby separating the movable iron core from the fixed iron core by the force of $F=FA+f-FM$.

- No supplying power to Control Circuit 12

When turning off Contact A with the movable iron core separated from the fixed iron core, the movable iron core holds that state by spring force f.

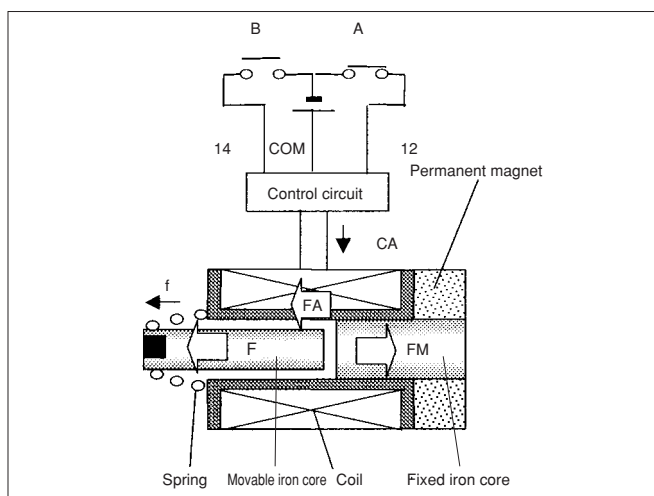

- Supplying power to Control Circuit 14

When turning on Contact B and supplying power to Control Circuit 14, force FB is generated to separate the movable iron core from the fixed iron core.

Force to which the attractive force FM of the permanent magnet is added exceeds the spring force, and thus the movable iron core is attracted to the fixed iron core by the force of $F=FB+FM-f$.

- No supplying power to Control Circuit 14

When turning off Contact B with the movable iron core attracted to the fixed iron core, the movable iron core is kept attracted by the permanent magnet.

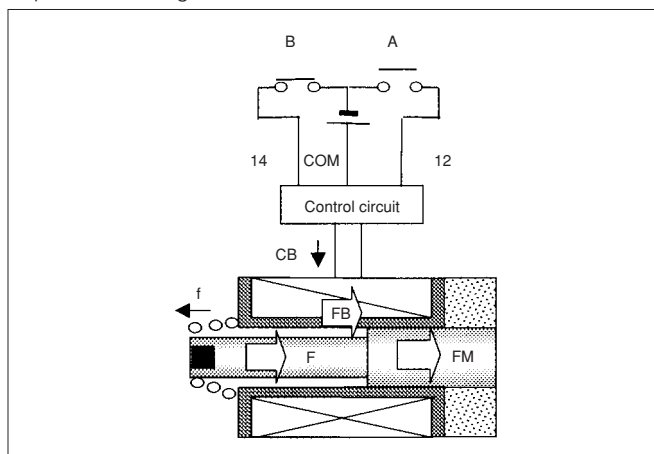



SOLENOID VALVE PC·RC1 SERIES/INDIVIDUAL INSTRUCTIONS

Be sure to read them before use.

Also refer to Par. "For Safety Use" and common instructions.

FLOW RATE

Flow rate can be calculated from the following formula :

For values in the sonic velocity zone, find out from the attached table.

① $P_H \leq 1.89P_L$ (Subsonic velocity zone)

$$Q = 240 \times S \times \sqrt{P_L \times (P_H - P_L)} \times \sqrt{\frac{293}{T_H}}$$

② $P_H \geq 1.89P_L$ (Sonic velocity zone)

$$Q = 120 \times S \times P_H \times P_H \times \sqrt{\frac{273}{T_H}}$$

Q : Flow rate ℓ /min(ANR)

S : Effective area of orifice mm²

P_H : Pressure on upper stream MPa abs

P_L : Pressure on down stream MPa abs

T_H : Absolute temperature on upper stream K

(Note) Absolute pressure (MPa) = Supply pressure + 0.100 (MPa)

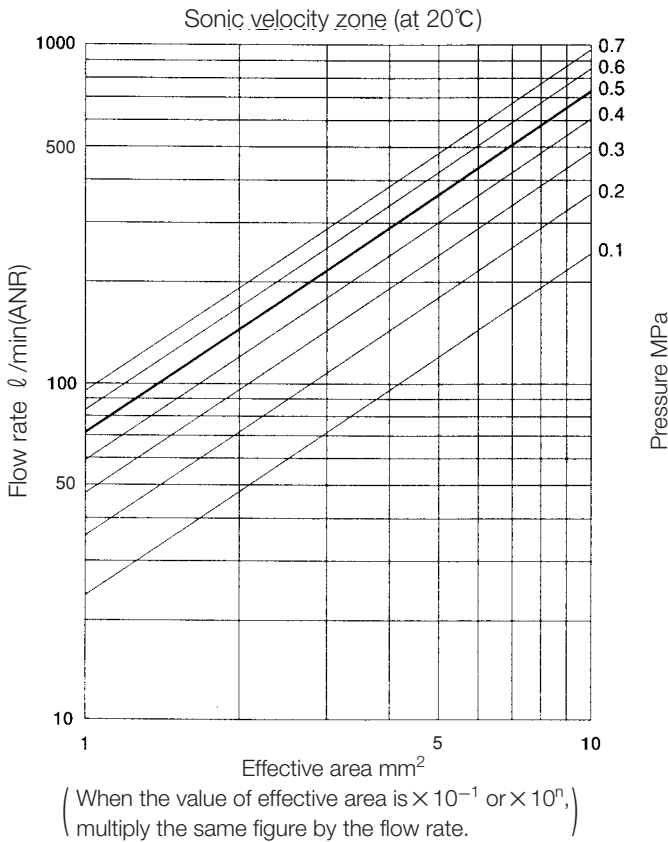

WIRING SPECIFICATIONS

●L type

Lead wire (AWG26 length 300mm)



●SP type

Connector with lead wire (AWG26 length 500mm), side outlet (with indicator light & surge suppressor)



●UP type

Connector with lead wire (AWG26 length 500mm), upside outlet (with indicator light & surge suppressor)



INTERNAL CIRCUIT OF SP & UP TYPE



CAUTION

- Make connection by adjusting polarity to ⊕ and ⊖ signs on the lamp cover.

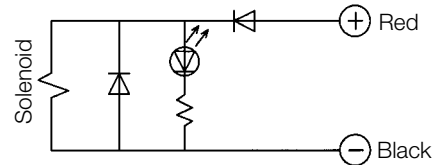

HOW TO USE CONNECTORS



CAUTION

- How to attach and detach a connector

When attaching a connector, pinch the clip with your finger and insert the connector into the pin straight to the end.

When detaching a connector, pinch the clip with your finger and pull out the connector straight.

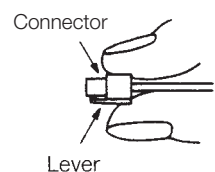
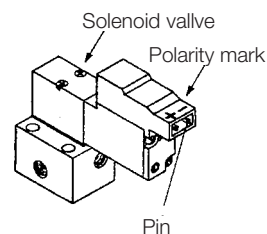

EFFECTIVE AREA

Effective areas mentioned in this catalog are measured between ports 1→2, 4 in accordance with JIS (JAPANESE INDUSTRIAL STANDARD) B8374/8375.

勝特力電材超市-龍山店 886-3-5773766
 勝特力電材超市-光復店 886-3-5729570
 勝特力電子(上海) 86-21-34970699
 勝特力電子(深圳) 86-755-83298787
<http://www.100y.com.tw>