

FEATURES

- Two AD8231 circuits
- In-amp and op amp
- Differential output
- Easy to switch jumpers
- Decoupled supply lines

GENERAL DESCRIPTION

The AD8231-EVALZ has two AD8231s mounted on it. Z1 is the AD8231 on the left side of the board. It is configured to allow access of the in-amp and op amp separately. Z2 is the AD8231 on the right side of the board. It is set up as a differential output configuration.

Inputs, outputs, references, and the supplies are routed to test points for easy connectivity. SDN, CS, and the gain select pins (A0 to A2) are routed to jumpers. These jumpers control both AD8231s. When a jumper is in the high position, its corresponding pin is connected to VS. When the jumper is in the low position, it is connected to ground.

The PCB has four layers. The top and bottom layers are used for routing, and the two internal layers are power and ground planes.

EVALUATION BOARD

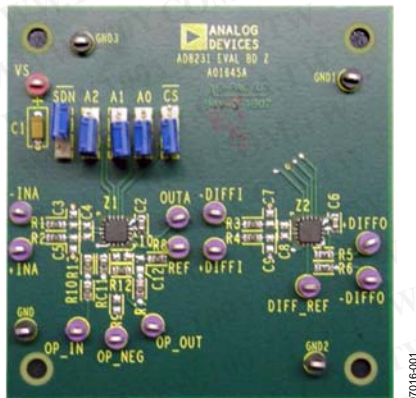

Figure 1.

勝特力材料 886-3-5753170
 勝特力电子(上海) 86-21-34970699
 勝特力电子(深圳) 86-755-83298787
[Http://www.100y.com.tw](http://www.100y.com.tw)

Rev. 0

Evaluation boards are only intended for device evaluation and not for production purposes. Evaluation boards are supplied "as is" and without warranties of any kind, express, implied, or statutory including, but not limited to, any implied warranty of merchantability or fitness for a particular purpose. No license is granted by implication or otherwise under any patents or other intellectual property by application or use of evaluation boards. Information furnished by Analog Devices is believed to be accurate and reliable. However, no responsibility is assumed by Analog Devices for its use, nor for any infringements of patents or other rights of third parties that may result from its use. Analog Devices reserves the right to change devices or specifications at any time without notice. Trademarks and registered trademarks are the property of their respective owners. Evaluation boards are not authorized to be used in life support devices or systems.

QUICK START

Set the jumpers as shown in Table 1. These jumper settings ensure the part is enabled and in a gain of 1.

Table 1. Quick Start Jumper Settings

Function	Setting
SDN	High
A2	Low
A1	Low
A0	Low
$\overline{\text{CS}}$	Low

Connect the ground lead to GND and connect a 5 V supply to +VS. Connect a 1 V source to -INA, and connect a 2 V source to +INA. 3.5 V should now appear at OUTA.

The output equation for the AD8231 with a gain of 1 is $V_{+INA} - V_{-INA} + V_{REF} = V_{OUT}$. As shipped, the evaluation board has the in-amp reference pin driven to half the supply voltage. Therefore, the output voltage is $2 \text{ V} - 1 \text{ V} + 2.5 \text{ V} = 3.5 \text{ V}$.

DUAL SUPPLIES

The supplies on the AD8231-EVALZ are labeled VS and GND because most applications are single supply. However, dual supplies can also be used with this evaluation board, as long as the difference between the two supplies is less than 6 V. Simply connect the negative supply to the GND terminal. For example, connect +2.5 V to +VS and -2.5 V to GND. Any voltage connected to GND also appears at the GND1, GND2, and GND3 terminals; therefore, take care when connecting external equipment.

CONFIGURING THE OP AMP

By default, the op amp in Z1 is configured as a unity-gain buffer driving the in-amp reference pin. A resistor divider at the op amp input sets the voltage at midsupply. When using this op amp for other applications, remove R8 and drive the in-amp REF pin with a different source.

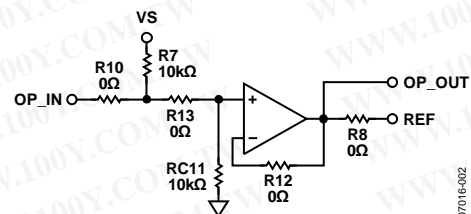

Figure 2. Default Op Amp Configuration

AD8231-EVALZ

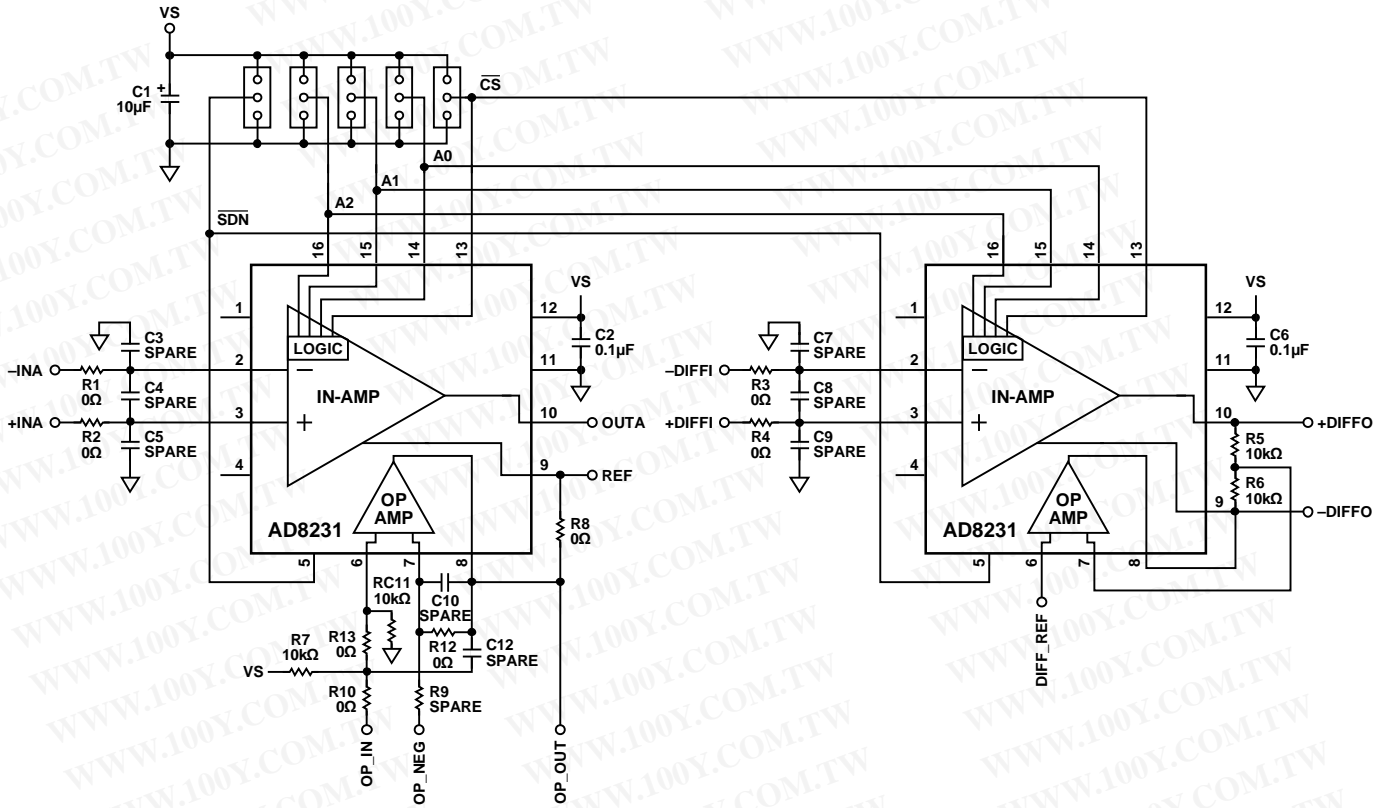

Figure 3. AD8231-EVALZ Schematic

Additional 0603 component pads have been placed and routed to allow several other types of op amp configurations. Figure 4 shows how to put the op amp in either an inverting or noninverting gain configuration. To make a noninverting configuration, drive the OP_IN pin with the incoming signal and the OP_NEG pin with a bias voltage. For an inverting configuration, drive the OP_NEG pin with the incoming signal and the OP_IN pin with a bias voltage.

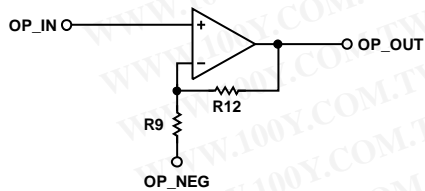

Figure 4. Inverting or Noninverting Configuration

The op amp can also be configured for filtering. Figure 5 shows how to make a Sallen-Key filter.

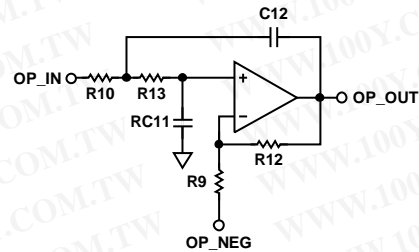

Figure 5. Sallen-Key Filter

ORDERING GUIDE

Model	Description
AD8231-EVALZ ¹	Evaluation Board

¹ Z = RoHS Compliant Part.

ESD CAUTION



ESD (electrostatic discharge) sensitive device. Charged devices and circuit boards can discharge without detection. Although this product features patented or proprietary protection circuitry, damage may occur on devices subjected to high energy ESD. Therefore, proper ESD precautions should be taken to avoid performance degradation or loss of functionality.

勝特力材料 886-3-5753170
 勝特力电子(上海) 86-21-34970699
 勝特力电子(深圳) 86-755-83298787
[Http://www.100y.com.tw](http://www.100y.com.tw)