

REV	ZONE	REVISION	DATE

NO.	NAME	MATERIAL	FINISH	Q'TY	REMARK
1	SHELL	BRASS T:0.30	NICKEL PLATED	1	Ni:80~120u"
2	BODY	LCP+GF 30%	GRAY	1	
3	TERMINAL	PHOS. BRONZE T:0.25	GOLD/TIN PLATED	19	Gold:15u"; Ni:40~60u" Tin:120~200u"

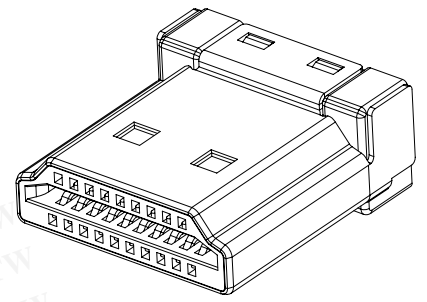
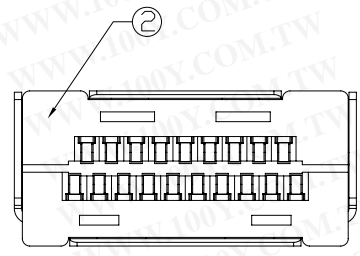
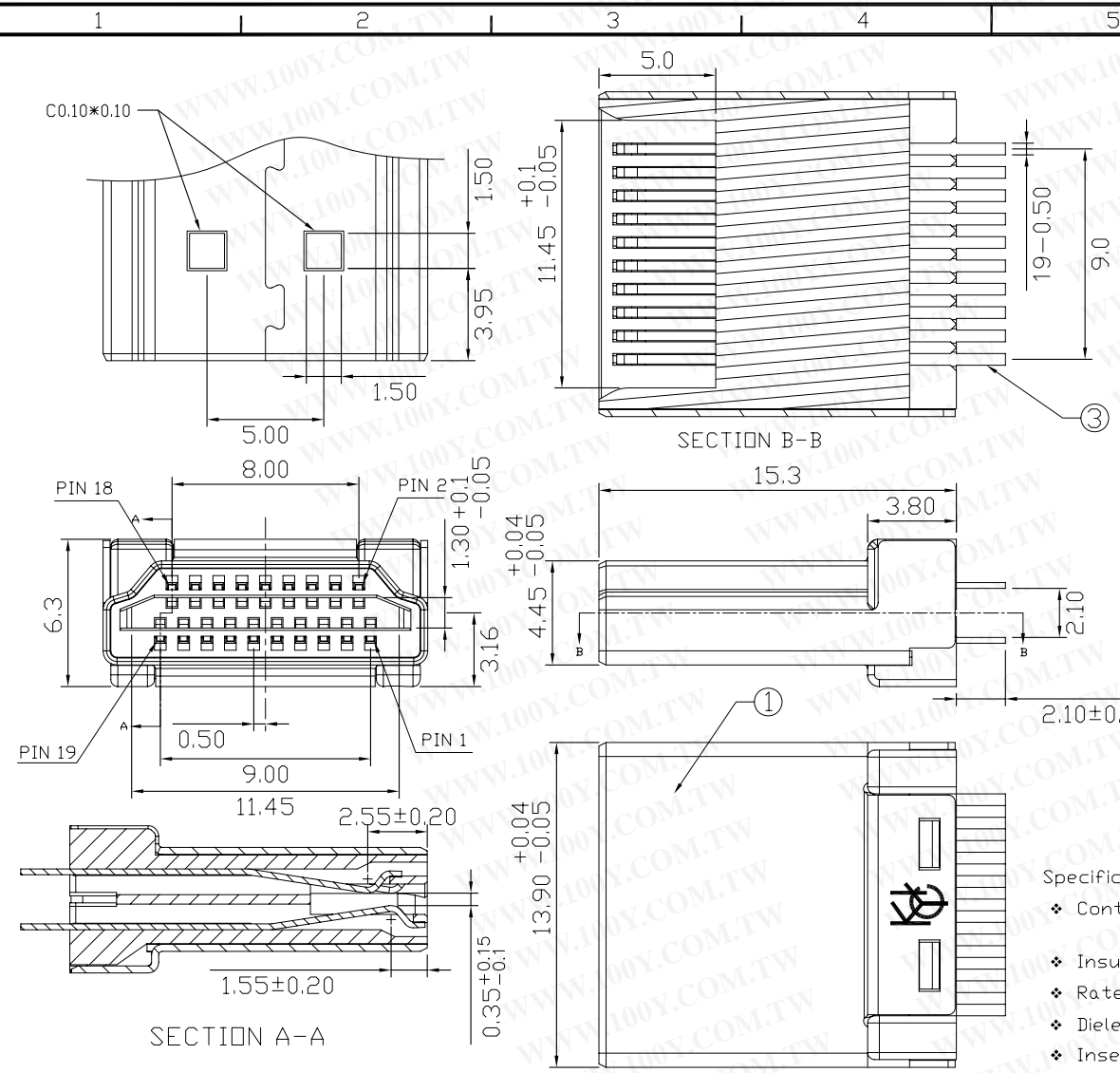

Specification:

- ❖ Contact Resistance: Unmated Plug Socket, 30m Ohm. Maximum.
Mated Plug Socket, 60m Ohm. Maximum.
- ❖ Insulation Resistance: 100M Ohm Min. At 500 VDC.
- ❖ Rated Voltage And Current: AC 40V,0.5A Minimum.
- ❖ Dielectric Withstanding Voltage: 500V AC (rms) For 1 Minute.
- ❖ Insertion Force: Type A- 44.1N Maximum.
- ❖ Extraction Force: Type A- 9.8N Minimum,39.2N Maximum.
- ❖ Durability: Type A- 10000 Cycles At 100±50 Cycles Per Hour.
Life Test After: Type A-Insertion/Extraction Force: 6N Minimum.
- ❖ Operating Temperature: -20°C ~ +85°C.



勝特力材料 886-3-5753170
 勝特力电子(上海) 86-21-54151736
 勝特力电子(深圳) 86-755-83298787
[Http://www.100y.com.tw](http://www.100y.com.tw)

COMPUTER NO.			UNIT	SCALE	PART NAME	
D:\DWG\HDMI-KPKD01-A02N2-L			mm	1:1	HDMI A PLUG	
APPD.	CKD.	DWG.	DATE	TOLERANCE	PART NO.	REV.
		TINA	27-12-07	X. +0.38 .X +0.25 .XX +0.13 .XXX ±0.05		

MODEL	HDMI-KPKD01-A02N2-L	PAGE 1 OF 1
-------	---------------------	-------------