

REVISIONS					
P	LTR	DESCRIPTION	DATE	DWN	APVD
M3		REVISED PER ECR-21-103739	20MAY2021	RZ	WK

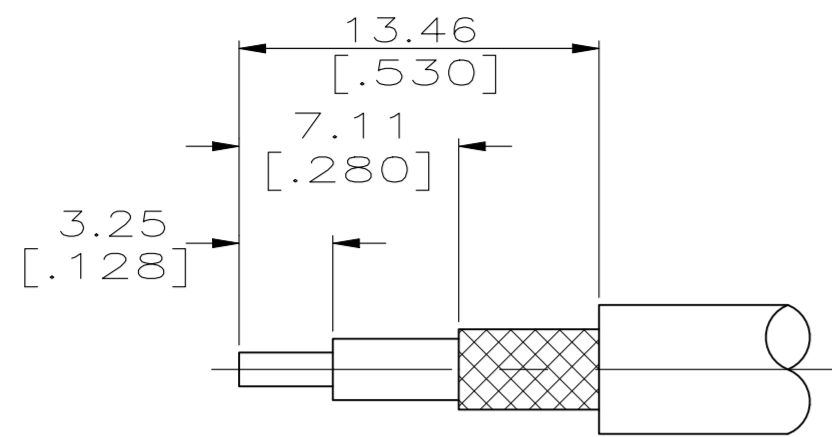

RECOMMENDED STRIP LENGTHS
SCALE NTS

勝特力材料 886-3-5753170
勝特力电子(上海) 86-21-34970699
勝特力电子(深圳) 86-755-83298787
[Http://www.100y.com.tw](http://www.100y.com.tw)

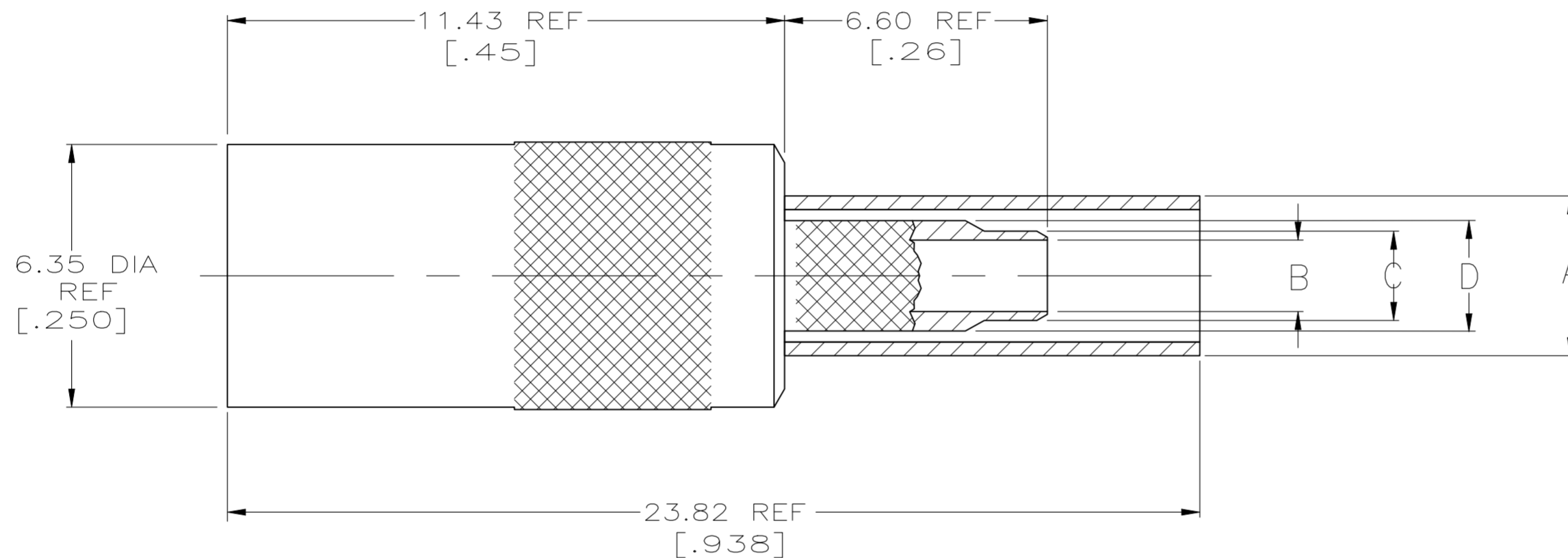

1. MATERIALS:
 BODY...BRASS PER QQ-B-626
 INNER AND OUTER CONTACTS...
 BERYLLIUM COPPER PER QQ-C-533
 DIELECTRIC...PTFE PER LP-403
2. FINISH:
 BODY,CENTER AND OUTER CONTACTS...
 GOLD PER MIL-G-45204 OVER
 NICKEL PER QQ-N-290
3. FINISH:
 BODY...NICKEL PER QQ-N-290 OVER
 COPPER PER MIL-C-14550
 CENTER AND OUTER CONTACTS...
 GOLD PER MIL-G-45204 OVER
 NICKEL PER QQ-N-290
4. FINISH:
 BODY AND OUTER CONTACT...NICKEL
 PER QQ-N-290 OVER COPPER PER
 MIL-C-14550
 CENTER CONTACT...GOLD PER
 MIL-G-45204 OVER NICKEL PER
 QQ-N-290
5. INTERFACE PER MIL-C-39012
6. SEE I.S. SHEET 2987-12

	B	58483-1	.128	HX4-1637	4	K699	2.64 [.104]	2.16 [.085]	1.70 [.067]	3.86 [.152]	4	RG 179,161,187	1-413985-2
	B	58483-1	.128	HX4-1637	4	K699	2.64 [.104]	2.16 [.085]	1.70 [.067]	3.86 [.152]	3	RG 179,161,187	1-413985-1
OBSOLETE	B	58483-1	.128	HX4-1637	4	K699	2.64 [.104]	2.16 [.085]	1.70 [.067]	3.86 [.152]	2	RG 179,161,187	1-413985-0
	A	58483-1	.105	HX4-1637	4	K699	1.98 [.076]	1.37 [.055]	0.96 [.040]	3.86 [.152]	4	RG 178,196	413985-9
	C	58483-1	.151	HX4-1637	4	K699	2.64 [.104]	2.16 [.085]	1.70 [.067]	4.54 [.179]	4	RG 174,188,316(ALL DBL SHIELDED)	413985-8
	B	58483-1	.128	HX4-1637	4	K699	2.64 [.104]	2.16 [.085]	1.70 [.067]	3.86 [.152]	4	RG 174,188,316	413985-7
OBSOLETE	A	58483-1	.105	HX4-1637	4	K699	1.98 [.076]	1.37 [.055]	0.96 [.040]	3.86 [.152]	3	RG 178,196	413985-6
	A	58483-1	.105	HX4-1637	4	K699	1.98 [.076]	1.37 [.055]	0.96 [.040]	3.86 [.152]	2	RG 178,196	413985-5
	C	58483-1	.151	HX4-1637	4	K699	2.64 [.104]	2.16 [.085]	1.70 [.067]	4.54 [.179]	3	RG 174,188,316(ALL DBL SHIELDED)	413985-4
	B	58483-1	.128	HX4-1637	4	K699	2.64 [.104]	2.16 [.085]	1.70 [.067]	3.86 [.152]	3	RG 174,188,316	413985-3
	C	58483-1	.151	HX4-1637	4	K699	2.64 [.104]	2.16 [.085]	1.70 [.067]	4.54 [.179]	2	RG 174,188,316(ALL DBL SHIELDED)	413985-2
	B	58483-1	.128	HX4-1637	4	K699	2.64 [.104]	2.16 [.085]	1.70 [.067]	3.86 [.152]	2	RG 174,188,316	413985-1
	POSITION LETTER	TE DIE SET	HEX SIZE	DANIELS DIE SET	SELECTOR NUMBER	DANIELS POSITIONER	D DIA REF	C DIA REF	B DIA REF	A DIA REF	NOTES	CABLE	PART NO
	PRO-CRIMPER FOR BRAID CRIMP		M 22520/5-01 FOR BRAID CRIMP		M 22520/2-01 FOR CONTACT CRIMP								

TOOLING INFORMATION

THIS DRAWING IS A CONTROLLED DOCUMENT.		DWN B. WERNER 16/MAY/94		
DIMENSIONS: mm [INCHES]		CHK J. McLEOD 16/MAY/94		
TOLERANCES UNLESS OTHERWISE SPECIFIED:		APVD J. McLEOD 16/MAY/94	NAME PLUG,STR CABLE,HEX CRIMP, OUTER FERRULE,CRIMP OR SOLDER CENTER CONTACT,SMB	
0 PLC ± - 1 PLC ± - 2 PLC ± 0.3 [.01] 3 PLC ± 0.13 [.005] 4 PLC ± - ANGLES ± -		PRODUCT SPEC -	SIZE A2	
MATERIAL -		APPLICATION SPEC -	CAGE CODE 00779	
FINISH -		WEIGHT 0.000000	DRAWING NO C=413985	
		CUSTOMER DRAWING	RESTRICTED TO -	
		SCALE 8:1	SHEET 1 OF 1	
			REV M3	