

LOC	DIST	REVISIONS			
P	LTR	DESCRIPTION	DATE	DWN	APVD
AJ	16				
A1		REVISED PER ECO-11-005030	11MAR11	RK	HMR

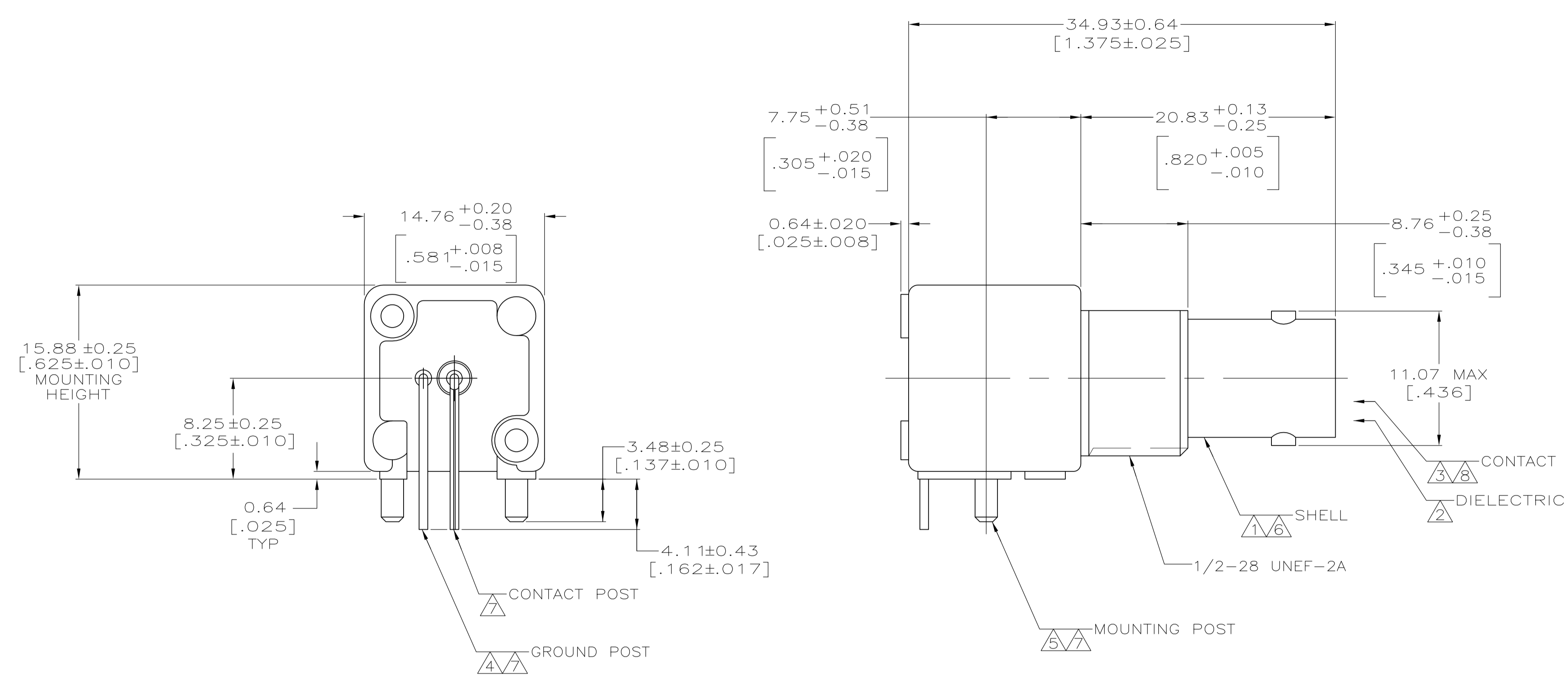

- 1 ZINC PER QQ-Z-363.
- 2 POLYMETHYLPENTENE PER ASTM D 1238.
- 3 PHOSPHOR BRONZE PER QQ-B-750.
- 4 BRASS PER ASTM B 453.
- 5 BRASS PER ASTM B 16.
- 6 NICKEL PLATE PER QQ-N-290, 3.81µm [.000150] MINIMUM THICK.
- 7 TIN PLATE PER ASTM B 545, 3.81µm [.000150] MINIMUM THICK.
- 8 GOLD PLATE PER ASTM B 488, 0.76µm [.000030] MINIMUM THICK.
- 9. SEE INSTRUCTION SHEET 408-2769.

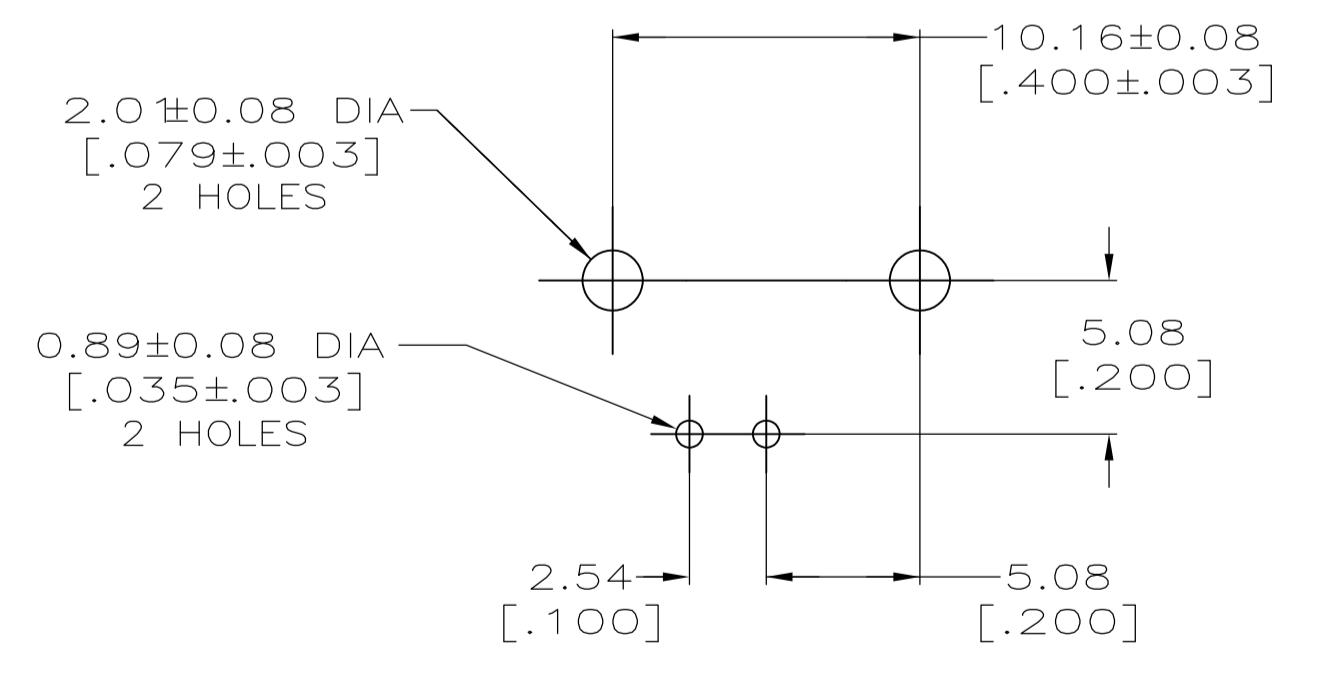
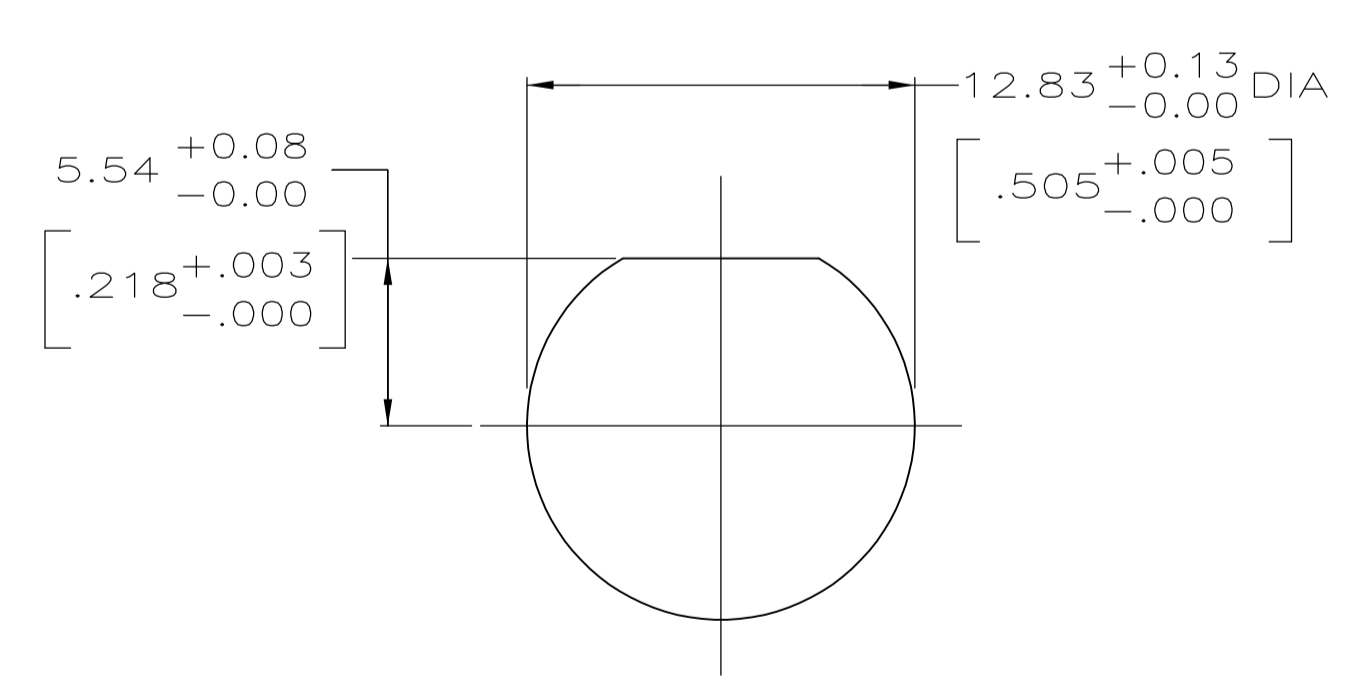

**勝特力材料 886-3-5753170**  
**勝特力电子(上海) 86-21-34970699**  
**勝特力电子(深圳) 86-755-83298787**  
[Http://www.100y.com.tw](http://www.100y.com.tw)

5227677-1  
PART NUMBER

THIS DRAWING IS A CONTROLLED DOCUMENT.		DIN L VARELA - DOCKS 20APR2005		TE Connectivity	
DIMENSIONS: mm [INCHES]		TOLERANCES UNLESS OTHERWISE SPECIFIED:			
0 PLC ± - 1 PLC ± - 2 PLC ± 0.05 [.002] 3 PLC ± - 4 PLC ± - ANGLES ± -		APVD J LIPPERT 23JUN2005 NAME PRODUCT SPEC 108-12078 APPLICATION SPEC		JACK, RIGHT ANGLE, PCB 50 OHM, SERIES BNC	
MATERIAL SEE NOTES		FINISH SEE NOTES		SIZE CAGE CODE DRAWING NO. RESTRICTED TO A1 00779 5227677	
CUSTOMER DRAWING		SCALE 4:1		SHEET 1 OF 1 REV A1	