

2-Cell, 500mA, Step-Up DC/DC Converter

FEATURES

- High Efficiency 90%.
- Adjustable Output Voltage with Two Resistors (AIC1631A)
- Power-Saving Shutdown Mode (7 μ A typical).
- Internal 2A Switch.
- 120KHz Switching Rate.
- Adjustable Switch Current Limit.
- On-Chip Low Battery Detector.

APPLICATIONS

- Palmtop & Notebook Computers.
- Pocket Organizers.
- Cameras.
- Pagers.
- Battery Backup Supplies.
- Portable Instruments.

DESCRIPTION

The AIC1631 is a high efficiency step up DC-DC converter. Only four external components are required to deliver a fixed voltage of 3V, 3.3V, or 5V. The output voltage can be externally set to an arbitrary value below breakdown voltage of the power switch for AIC1631A. Efficiency beyond 87% can be easily achieved at 100mA load with 2.2V to 3V input voltages.

Logic-controlled shutdown mode is provided for power saving. Switch current limit can be programmed with a resistor. The low battery detector can be configured as a linear regulator or a burst mode controller performing an extremely low supply current operation.

120KHz switching rate reduces the inductor size. Inductors of 25 μ H to 50 μ H inductance are recommended for most applications.

TYPICAL APPLICATION CIRCUIT

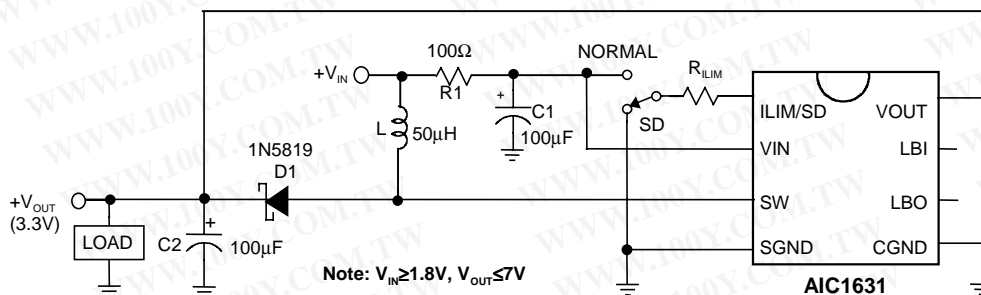

High Efficiency Step-Up DC/DC Converter

ORDERING INFORMATION

AIC1631 XXX

- PACKAGE TYPE
N: PLASTIC DIP
S: SMALL OUTLINE
- TEMPERATURE RANGE
C=0°C~+70°C
- OUTPUT VOLTAGE
DEFAULT: 3.3V
3: 3.0V
5: 5.0V
A: Adjustable

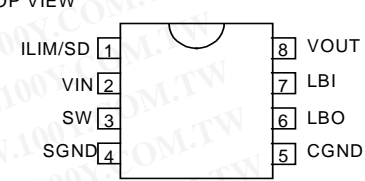
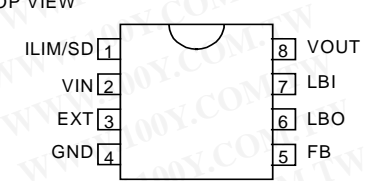
ORDER NUMBER	PIN CONFIGURATION
AIC1631CN AIC1631-3CN AIC1631-5CN (PLASTIC DIP)	TOP VIEW 
AIC1631CS AIC1631-3CS AIC1631-5CS (PLASTIC SO)	TOP VIEW 

ABSOLUTE MAXIMUM RATINGS

- Supply Voltage 7.0V
- Operating Temperature Range..... -20°C ~ 80°C
- Storage Temperature Range -65°C ~ 150°C

TEST CIRCUIT

Refer to Typical Application Circuit.

ELECTRICAL CHARACTERISTICS (V_{IN}=3.0V, T_a=25°C, unless otherwise specified.)

PARAMETER	TEST CONDITIONS	MIN.	TYP.	MAX.	UNIT
Input Voltage	Fig. 4 in Appl. Examples	1.5		7	V
Output Voltage	I _{LOAD} =200mA				
	AIC1631	3.16	3.3	3.44	V
	AIC1631-3	2.88	3	3.12	
	AIC1631-5	4.80	5	5.20	
Switch off Current			105	140	μA
No Load Current	AIC1631/AIC1631-3		160		μA
	AIC1631-5		180		
Shutdown Mode Current			7	15	μA
Shutdown Recovery Time	V _{IN} =2.5V, I _{LOAD} =200mA		0.4		mS

■ ELECTRICAL CHARACTERISTICS (CONTINUED)

PARAMETER	TEST CONDITIONS	MIN.	TYP.	MAX.	UNIT
Efficiency	$I_{LOAD} = 200mA$ AIC1631/AIC1631-3 AIC1631-5		87 90		%
Line Regulation	$I_{LOAD} = 100mA$ AIC1631, $V_{IN} = 1.8 \sim 3.3V$ AIC1631-3, $V_{IN} = 1.8 \sim 3V$ AIC1631-5, $V_{IN} = 2.2 \sim 3.3V$		0.6 0.5 0.8		% V_{OUT}
Load Regulation	$I_{LOAD} = 10 \sim 300mA$ AIC1631/AIC1631-3 AIC1631-5		0.3 0.8		% V_{OUT}
Oscillator Frequency		90	120	150	KHz
LBI Pin Trip Point		1.17	1.22	1.27	V
FB Threshold Voltage	AIC1631A	0.598	0.617	0.636	V
SW "ON Resistance"	AIC1631/AIC1631-3 AIC1631-5		0.5 0.4		Ω
LBO "ON Resistance"	$V_{IN} = 2V$		45		Ω
SW Off Leakage				1	μA
Input Pin Bias Current				10	nA/Pin
Output Pin Leakage				10	nA/Pin

■ TYPICAL PERFORMANCE CHARACTERISTICS

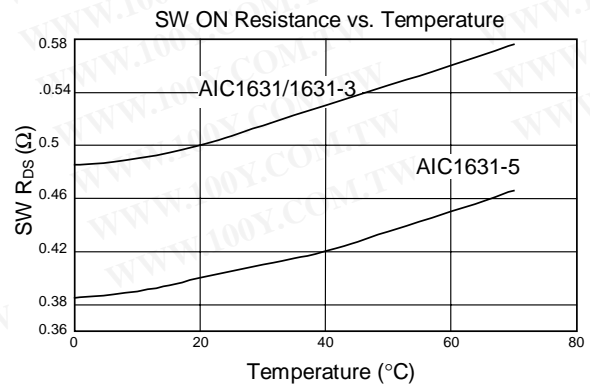
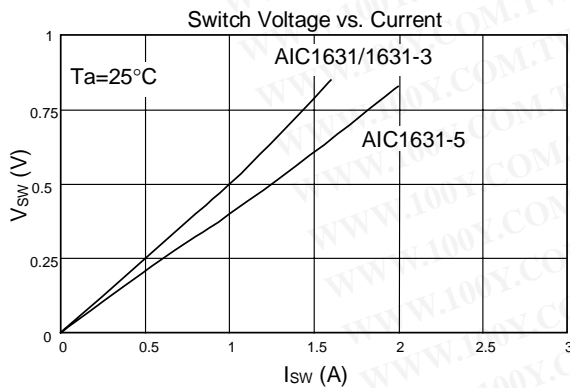

■ TYPICAL PERFORMANCE CHARACTERISTICS (CONTINUED)

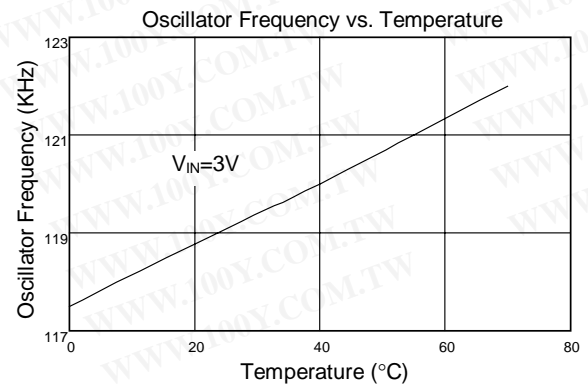
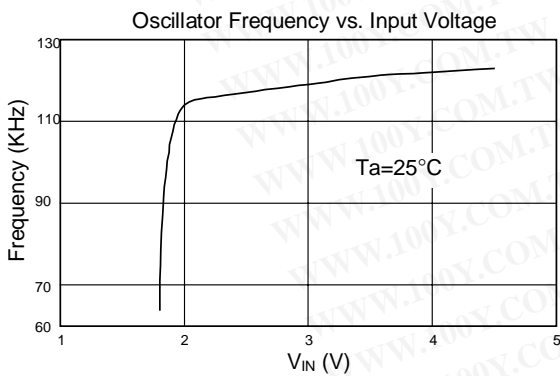
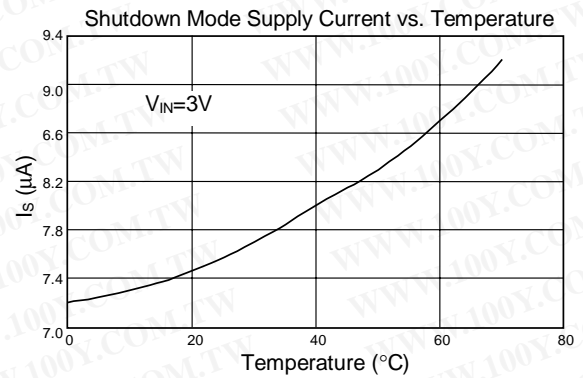
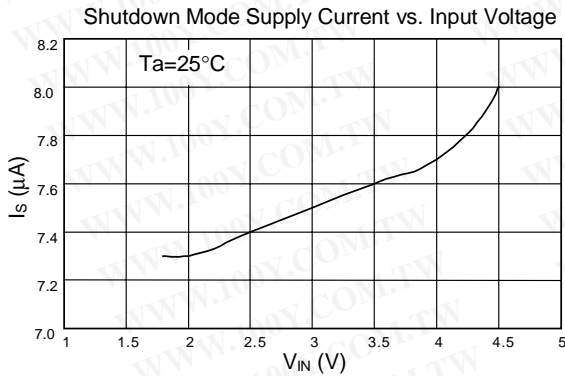
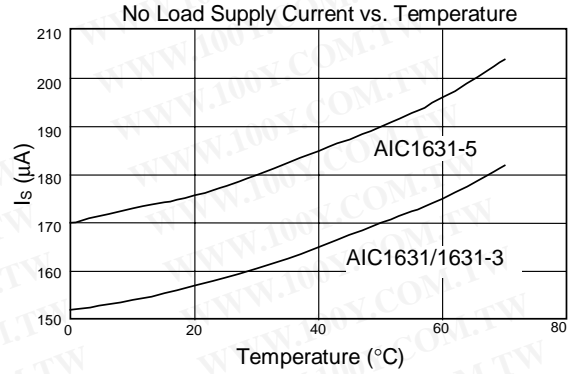
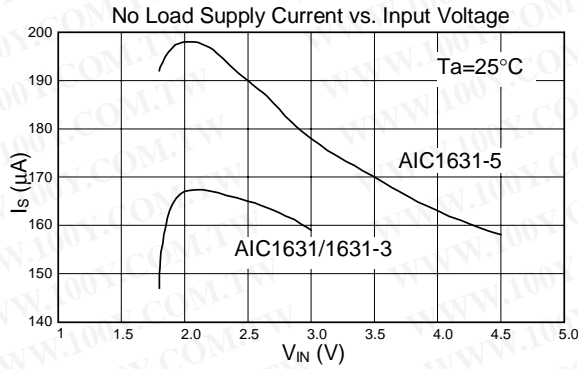

■ TYPICAL PERFORMANCE CHARACTERISTICS (CONTINUED)

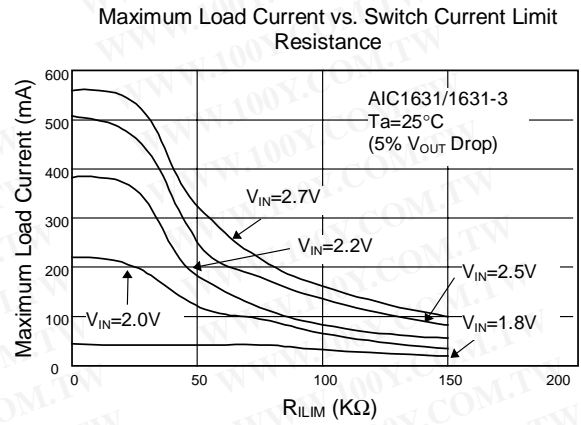
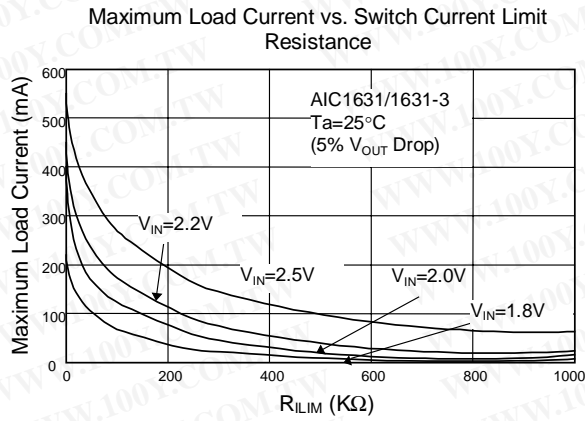

■ BLOCK DIAGRAM

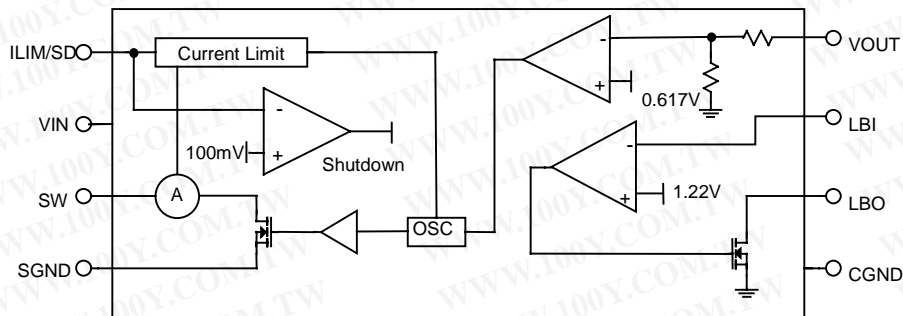



PIN DESCRIPTIONS

AIC1631/ AIC1631-3 / AIC1631-5

- PIN 1: ILIM/SD- 1. Connected to VIN pin through a resistor to set the switch peak current. It serves to protect IC and inductor, as well as to improve efficiency and output ripples. However, supply capability of the AIC1631 is limited by the current limit resistor. (See typical performance characteristics). The ILIM/SD pin should be shorted to VIN pin if limiting on switch peak current is not intended.
2. The AIC1631 goes in shut-down mode and consumes less than 10 μ A when ILIM/SD pin is pulled to ground.
- PIN 2: VIN - Input supply.
- PIN 3: SW - Drain of the power switch, to be connected to inductor/ diode.
- PIN 4:SGND - Ground connected to source of power switch.
- PIN 5:CGND - Ground for control circuits of the IC. It should be separated from SGND to avoid the interference.
- PIN 6:LBO - Open drain output of the battery low detector, with 45 Ω "ON resistance" at $V_{IN}=2V$. It is pulled low when the voltage on LBI pin is below 1.22V.
- PIN 7:LBI - The noninverting input of the battery low detector, of which the inverting input is internally connects to 1.22V voltage reference.
- PIN 8:VOUT - The output voltage feedbacks to the IC through this pin.

AIC1631A

- PIN 1: ILIM/SD- 1. Connected to VIN pin through a resistor to set the switch peak current. It serves to protect IC and inductor, as well as to improve efficiency and output ripples. However, supply capability of the AIC1631A is limited by the current limit resistor. (See typical performance characteristics). The ILIM/SD pin should be shorted to VIN pin if limiting on switch peak current is not intended.
2. The AIC1631A goes in shut-down mode and consumes less than 10 μ A when ILIM/SD pin is pulled to ground.
- PIN 2: VIN - Input supply.
- PIN 3: SW - Drain of the power switch, to be connected to inductor/ diode.
- PIN 4: GND - Ground.
- PIN 5: FB - Output voltage can either be internally set to 5 volt by grounding FB pin, or be externally set to an arbitrary voltage by applying to FB pin the divider voltage of two divider resistors.
- VOUT voltage is given by the following equation:
- $$\frac{R1}{R2} = \frac{VOUT}{0.617} - 1$$
- where R1 = Resistor connected between FB pin and VOUT pin.
- R2= Resistor connected between FB pin and ground.
- VOUT=Output voltage to be set.
- PIN 6: LBO - Open drain output of the battery low detector, with 45 Ω "ON resistance" at $V_{IN}=2V$. It is pulled low when the voltage on LBI pin is below 1.22V.

AIC1631A (continued)

PIN 7: LBI - The noninverting input of the battery low detector, of which the inverting input is internally connects to 1.22V voltage reference.

PIN 8: VOUT- The output voltage feedbacks to the IC through this pin. If output voltage was externally set, the VOUT pin can be tied to any low impedance node with voltage between the external switch threshold and 7V

APPLICATION EXAMPLES

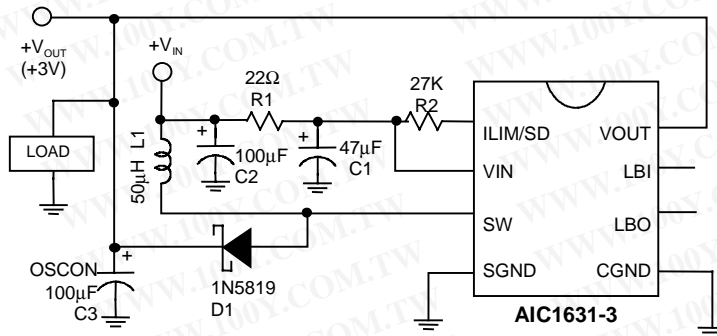

Fig. 1 3V Output Step-Up Converter

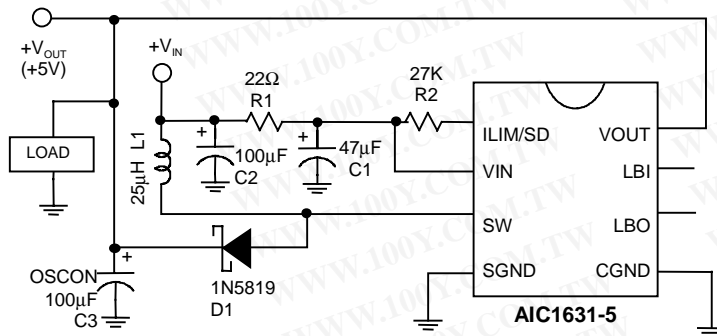
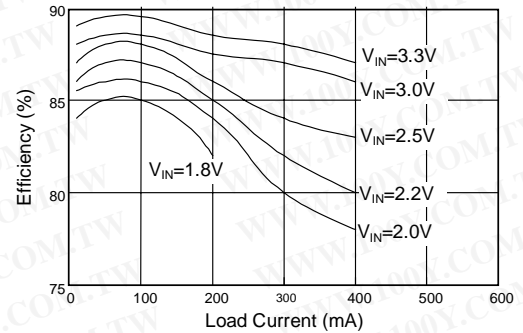
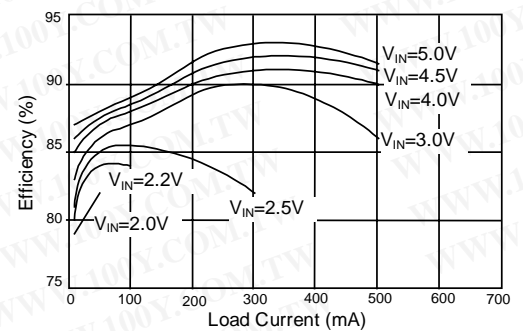

Fig. 2 5V Output Step-Up Converter



APPLICATION EXAMPLES (CONTINUED)

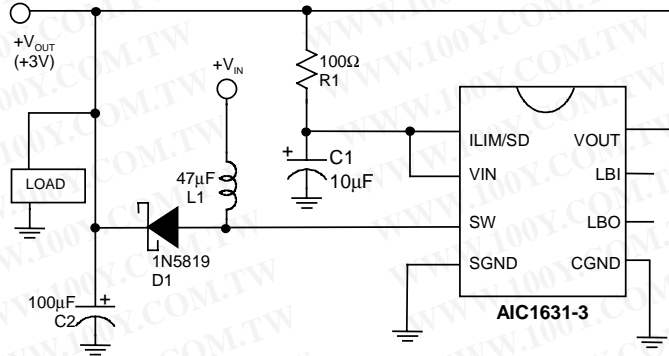

Fig. 3 1-Cell Input 3V Output Step-Up Converter

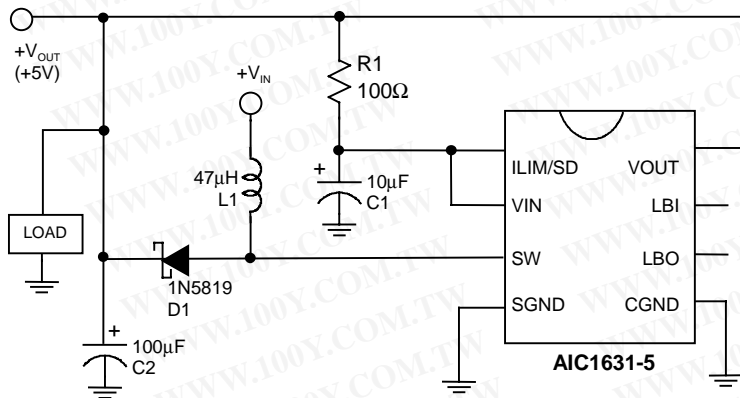
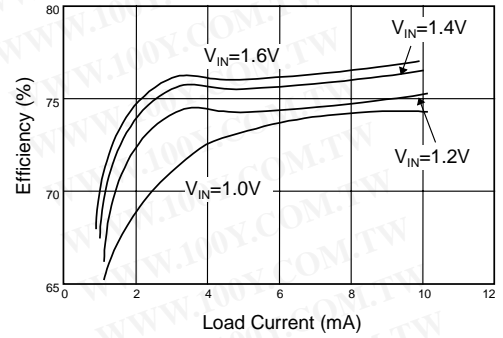

Fig. 4 1-Cell Input 5V Output Step-Up Converter

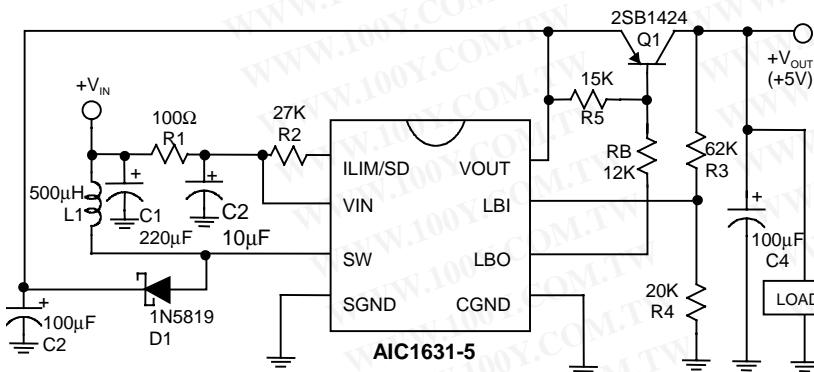
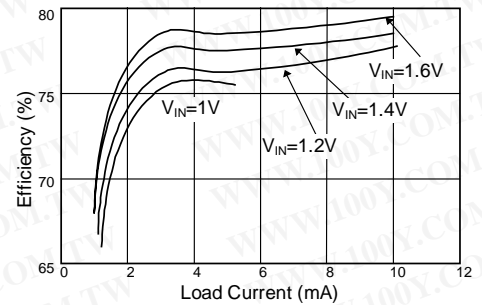
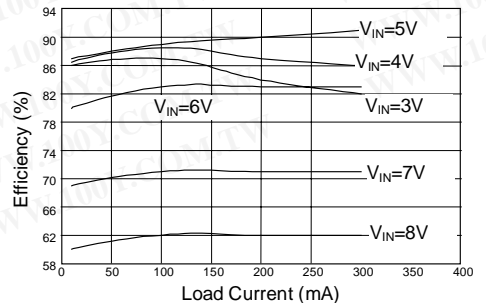

Fig. 5 4-Cell Input Step-Up / Step-Down Converter



APPLICATION EXAMPLES (CONTINUED)

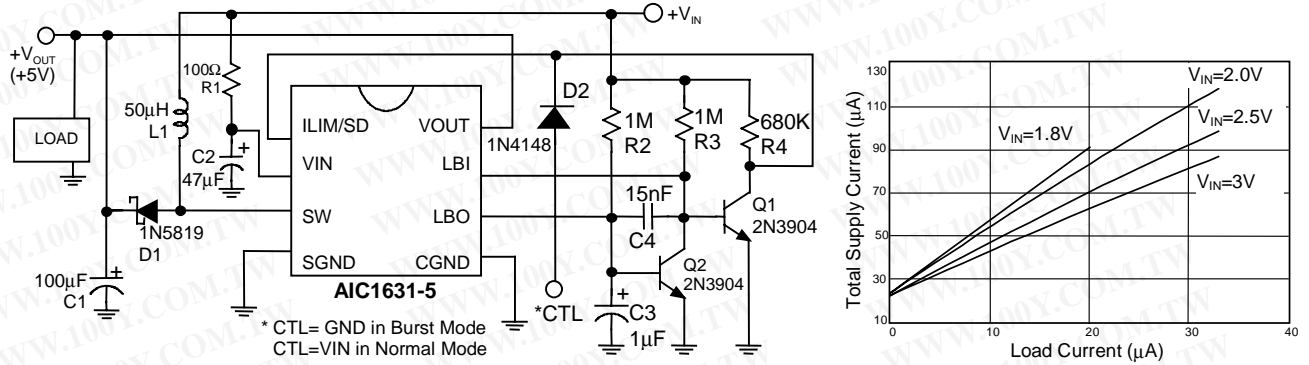

Fig. 6 Low Supply Current Burst Mode Step-Up Converter

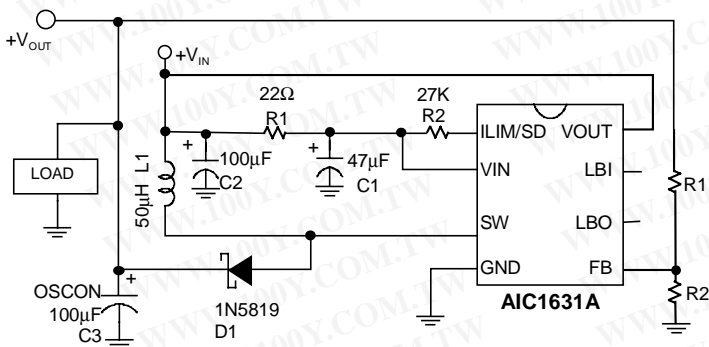
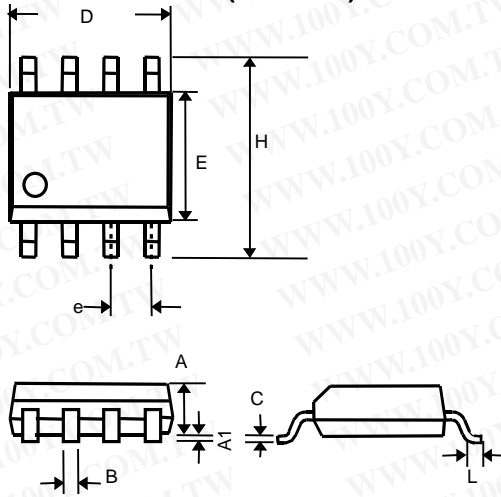

Fig.7 Adjustable Output Voltage Step-Up Converter

PHYSICAL DIMENSION

● **8 LEAD PLASTIC SO (unit: mm)**



SYMBOL	MIN	MAX
A	1.35	1.75
A1	0.10	0.25
B	0.33	0.51
C	0.19	0.25
D	4.80	5.00
E	3.80	4.00
e	1.27(TYP)	
H	5.80	6.20
L	0.40	1.27

● **8 LEAD PLASTIC DIP (unit: mm)**

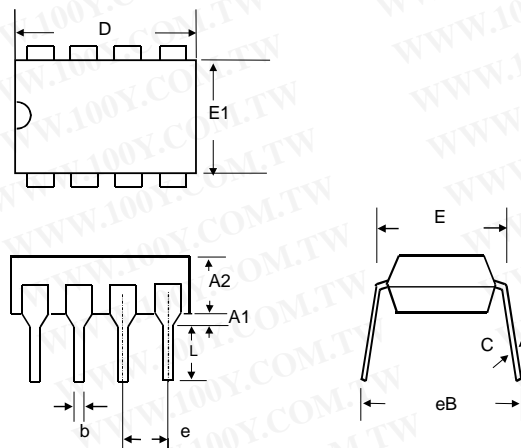

SYMBOL	MIN	MAX
A1	0.381	—
A2	2.92	4.96
b	0.35	0.56
C	0.20	0.36
D	9.01	10.16
E	7.62	8.26
E1	6.09	7.12
e	2.54 (TYP)	
eB	—	10.92
L	2.92	3.81