

REV. 更改	DESCRIPTION 說明	ENG. 修改人	APPROVE 審核
------------	-------------------	-------------	---------------

勝特力材料 886-3-5753170  
 勝特力电子(上海) 86-21-54151736  
 勝特力电子(深圳) 86-755-83298787  
[Http://www.100y.com.tw](http://www.100y.com.tw)

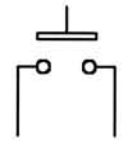
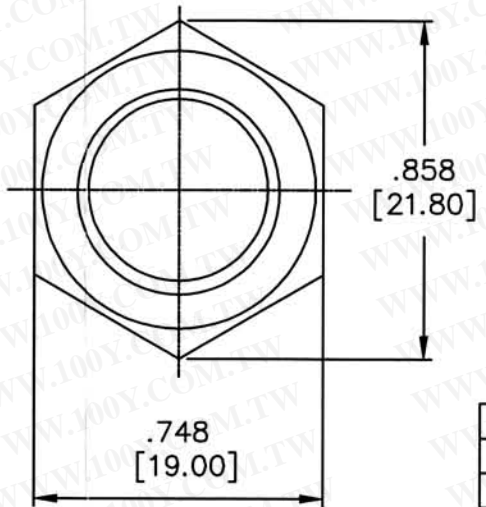
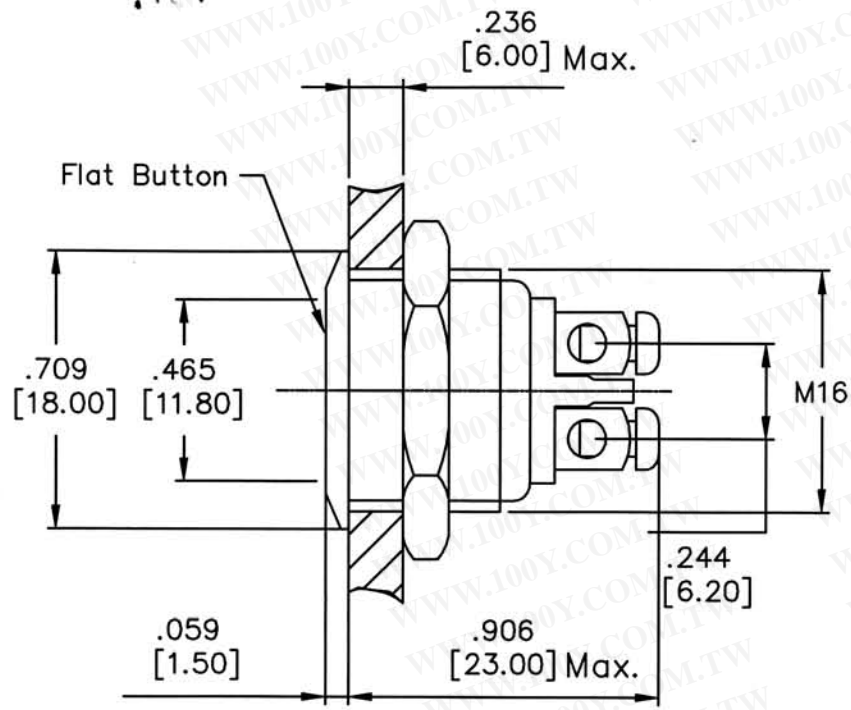

CONTACT CONFIGURATION

Code	Bushing & Button Material
B3	Nickel plated brass with varnished polished
B31	Gold plated brass with varnished polished
B32	Stainless steel with varnished polished

**SPECIFICATIONS:**

- Contact Rating: 2A @ 36VDC.
- Electrical Life: 200,000cycles.
- Contact Resistance: 50m-ohms max (initial).
- Insulation Resistance: 1,000M-ohms min @ 500VDC.
- Dielectric Strength: 2,000V RMS 50~60Hz.
- Operating Temperature: -20°C ~ +70°C.
- Switching Circuit: OFF-MOM.
- IP Class: IP65 protection.
- Torque: 5~14Nm max. applied to nut.
- Operating Force: 5.5N max.

**MATERIALS:**

- Bushing & Button: Refer to above table
- Contact: Silver alloy.
- Nut: Nickel plated brass.
- Base: PBT.

THESE DRAWINGS AND SPECIFICATIONS ARE THE PROPERTY OF TAIWAY ELECTRONICS LTD. AND SHALL NOT BE REPRODUCED COPIED OR USED IN ANY MANNER WITHOUT THE PRIOR WRITTEN CONSENT OF TAIWAY ELECTRONICS LTD.

DIMENSIONS	TOLERANCE
0.00 TO 30.00mm	±0.20mm
30.01 TO 80.00mm	±0.25mm
80.01 TO 150.00mm	±0.30mm
150.01	±0.40mm

ITEM NO. 料號	AV01-B3-M1-F
----------------	--------------

USED 用途	AV	APPD. 審核	Amy 2007/11/29		
FINISH 處理		CHKD. 校對	Amy 2007/11/29		
SCALE 比例	2 / 1	DR. 製圖	Amy 2007/11/29		
TITLE 名稱	Anti-Vandal Switch				
DWG NO. 圖號	AV01-B3(B3x)-M1-F			SIZE 圖紙	A4
FILE NAME 檔案名稱	AV01B3M1F.DWG			SHEET 張數	1 / 1
		REV. 更改	1		