

March 1988

CD4017BM/CD4017BC Decade Counter/Divider with 10 Decoded Outputs CD4022BM/CD4022BC Divide-by-8 Counter/Divider with 8 Decoded Outputs

General Description

The CD4017BM/CD4017BC is a 5-stage divide-by-10 Johnson counter with 10 decoded outputs and a carry out bit.

The CD4022BM/CD4022BC is a 4-stage divide-by-8 Johnson counter with 8 decoded outputs and a carry-out bit.

These counters are cleared to their zero count by a logical "1" on their reset line. These counters are advanced on the positive edge of the clock signal when the clock enable signal is in the logical "0" state.

The configuration of the CD4017BM/CD4017BC and CD4022BM/CD4022BC permits medium speed operation and assures a hazard free counting sequence. The 10/8 decoded outputs are normally in the logical "0" state and go to the logical "1" state only at their respective time slot. Each decoded output remains high for 1 full clock cycle. The carry-out signal completes a full cycle for every 10/8 clock input cycles and is used as a ripple carry signal to any succeeding stages.

Features

- Wide supply voltage range
- High noise immunity
- Low power TTL compatibility
- Medium speed operation
- Low power
- Fully static operation

3.0V to 15V
 0.45 V_{DD} (typ.)
 Fan out of 2 driving 74L
 or 1 driving 74LS
 5.0 MHz (typ.)
 with 10V V_{DD}
 10 μ W (typ.)

Applications

- Automotive
- Instrumentation
- Medical electronics
- Alarm systems
- Industrial electronics
- Remote metering

Connection Diagrams

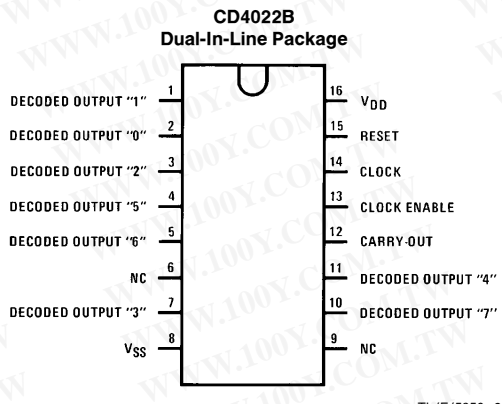
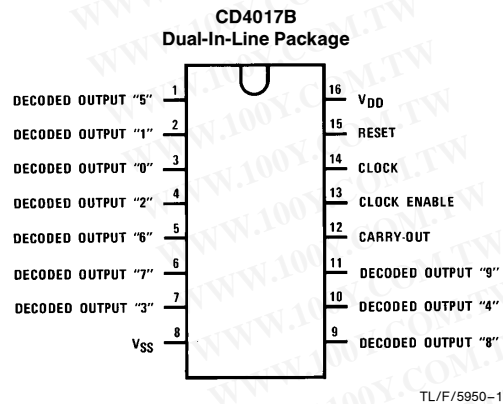

Order Number CD4017B or CD4022B

CD4017BM/CD4017BC Decade Counter/Divider with 10 Decoded Outputs
 CD4022BM/CD4022BC Divide-by-8 Counter/Divider with 8 Decoded Outputs

Absolute Maximum Ratings (Notes 1 & 2)

If Military/Aerospace specified devices are required, please contact the National Semiconductor Sales Office/Distributors for availability and specifications.

DC Supply Voltage (V_{DD})	-0.5 V_{DC} to +18 V_{DC}
Input Voltage (V_{IN})	-0.5 V_{DC} to V_{DD} +0.5 V_{DC}
Storage Temperature (T_S)	-65°C to +150°C
Power Dissipation (P_D)	
Dual-In-Line	700 mW
Small Outline	500 mW
Lead Temperature (T_L)	
(Soldering, 10 seconds)	260°C

Recommended Operating Conditions (Note 2)

DC Supply Voltage (V_{DD})	+3 V_{DC} to +15 V_{DC}
Input Voltage (V_{IN})	0 to V_{DD} V_{DC}
Operating Temperature Range (T_A)	
CD4017BM, CD4022BM	-55°C to +125°C
CD4017BC, CD4022BC	-40°C to +85°C

DC Electrical Characteristics CD4017BM, CD4022BM (Note 2)

Symbol	Parameter	Conditions	-55°C		+25°			+125°C		Units
			Min	Max	Min	Typ	Max	Min	Max	
I_{DD}	Quiescent Device Current	$V_{DD} = 5V, V_{IN} = V_{DD}$ or V_{SS}		5	0.3	5		150	μA	
		$V_{DD} = 10V, V_{IN} = V_{DD}$ or V_{SS}		10	0.5	10		300	μA	
		$V_{DD} = 15V, V_{IN} = V_{DD}$ or V_{SS}		20	1.0	20		600	μA	
V_{OL}	Low Level Output Voltage	$ I_O < 1.0 \mu A$			0					
		$V_{DD} = 5V$		0.05	0	0.05		0.05	V	
		$V_{DD} = 10V$		0.05	0	0.05		0.05	V	
V_{OH}	High Level Output Voltage	$ I_O < 1.0 \mu A$								
		$V_{DD} = 5V$	4.95		4.95	5		4.95	V	
		$V_{DD} = 10V$	9.95		9.95	10		9.95	V	
V_{IL}	Low Level Input Voltage	$ I_O < 1.0 \mu A$								
		$V_{DD} = 5V, V_O = 0.5V$ or 4.5V		1.5			1.5		V	
		$V_{DD} = 10V, V_O = 1.0V$ or 9.0V		3.0			3.0		V	
V_{IH}	High Level Input Voltage	$ I_O < 1.0 \mu A$								
		$V_{DD} = 5V, V_O = 0.5V$ or 4.5V	3.5		3.5			3.5	V	
		$V_{DD} = 10V, V_O = 1.0V$ or 9.0V	7.0		7.0			7.0	V	
I_{OL}	Low Level Output Current (Note 3)	$V_{DD} = 5V, V_O = 0.4V$	0.64		0.51	0.88		0.36	mA	
		$V_{DD} = 10V, V_O = 0.5V$	1.6		1.3	2.25		0.9	mA	
		$V_{DD} = 15V, V_O = 1.5V$	4.2		3.4	8.8		2.4	mA	
I_{OH}	High Level Output Current (Note 3)	$V_{DD} = 5V, V_O = 4.6V$	-0.25		-0.2	-0.36		-0.14	mA	
		$V_{DD} = 10V, V_O = 9.5V$	-0.62		-0.5	-0.9		-0.35	mA	
		$V_{DD} = 15V, V_O = 13.5V$	-1.8		-1.5	-3.5		-1.1	mA	
I_{IN}	Input Current	$V_{DD} = 15V, V_{IN} = 0V$		-0.1		-10^{-5}	-0.1		μA	
		$V_{DD} = 15V, V_{IN} = 15V$		0.1		10^{-5}	0.1		μA	

DC Electrical Characteristics CD4017BC, CD4022BC (Note 2)

Symbol	Parameter	Conditions	-40°C		+25°			+85°C		Units
			Min	Max	Min	Typ	Max	Min	Max	
I_{DD}	Quiescent Device Current	$V_{DD} = 5V$		20		0.5	20		150	μA
		$V_{DD} = 10V$		40		1.0	40		300	μA
		$V_{DD} = 15V$		80		5.0	80		600	μA
V_{OL}	Low Level Output Voltage	$ I_O < 1.0 \mu A$								
		$V_{DD} = 5V$		0.05		0	0.05		0.05	V
		$V_{DD} = 10V$		0.05		0	0.05		0.05	V
V_{OH}	High Level Output Voltage	$ I_O < 1.0 \mu A$								
		$V_{DD} = 5V$	4.95		4.95	5		4.95	V	
		$V_{DD} = 10V$	9.95		9.95	10		9.95	V	
V_{OH}	High Level Output Voltage	$V_{DD} = 15V$	14.95		14.95	15		14.95	V	

Note 1: "Absolute Maximum Ratings" are those values beyond which the safety of the device cannot be guaranteed, they are not meant to imply that the devices should be operated at these limits. The table of "Recommended Operating Conditions" and "Electrical Characteristics" provides conditions for actual device operation.

Note 2: $V_{SS} = 0V$ unless otherwise specified.

Note 3: I_{OL} and I_{OH} are tested one output at a time.

DC Electrical Characteristics CD4017BC, CD4022BC (Note 2) (Continued)

Symbol	Parameter	Conditions	- 40°C		+ 25°			+ 85°C		Units	
			Min	Max	Min	Typ	Max	Min	Max		
V _{IL}	Low Level Input Voltage	I _O < 1.0 μA V _{DD} = 5V, V _O = 0.5V or 4.5V V _{DD} = 10V, V _O = 1.0V or 9.0V V _{DD} = 15V, V _O = 1.5V or 13.5V									
							1.5		1.5	V	
							3.0		3.0	3.0	V
							4.0		4.0	4.0	V
V _{IH}	High Level Input Voltage	I _O < 1.0 μA V _{DD} = 5V, V _O = 0.5V or 4.5V V _{DD} = 10V, V _O = 1.0V or 9.0V V _{DD} = 15V, V _O = 1.5V or 13.5V	3.5		3.5			3.5		V	
			7.0		7.0			7.0		V	
			11.0		11.0			11.0		V	
I _{OL}	Low Level Output Current (Note 3)	V _{DD} = 5V, V _O = 0.4V V _{DD} = 10V, V _O = 0.5V V _{DD} = 15V, V _O = 1.5V	0.52		0.44	0.88		0.36		mA	
			1.3		1.1	2.25		0.9		mA	
			3.6		3.0	8.8		2.4		mA	
I _{OH}	High Level Output Current (Note 3)	V _{DD} = 5V, V _O = 4.6V V _{DD} = 10V, V _O = 9.5V V _{DD} = 15V, V _O = 13.5V	-0.2		-0.16	-0.36		-0.12		mA	
			-0.5		-0.4	-0.9		-0.3		mA	
			-1.4		-1.2	-3.5		-1.0		mA	
I _{IN}	Input Current	V _{DD} = 15V, V _{IN} = 0V V _{DD} = 15V, V _{IN} = 15V		-0.3		-10 ⁻⁵	-0.3		-1.0	μA	
				0.3		10 ⁻⁵	0.3		1.0	μA	

Note 1: "Absolute Maximum Ratings" are those values beyond which the safety of the device cannot be guaranteed, they are not meant to imply that the devices should be operated at these limits. The table of "Recommended Operating Conditions" and "Electrical Characteristics" provides conditions for actual device operation.

Note 2: V_{SS} = 0V unless otherwise specified.

Note 3: I_{OL} and I_{OH} are tested one output at a time.

AC Electrical Characteristics*

T_A = 25°C, C_L = 50 pF, R_L = 200k, t_{rCL} and t_{fCL} = 20 ns, unless otherwise specified

Symbol	Parameter	Conditions	Min	Typ	Max	Units
CLOCK OPERATION						
t _{PHL} , t _{PLH}	Propagation Delay Time Carry Out Line	V _{DD} = 5V		415	800	ns
		V _{DD} = 10V		160	320	ns
		V _{DD} = 15V		130	250	ns
	Carry Out Line	V _{DD} = 5V	} C _L = 15 pF	240	480	ns
		V _{DD} = 10V		85	170	ns
		V _{DD} = 15V		70	140	ns
	Decode Out Lines	V _{DD} = 5V		500	1000	ns
		V _{DD} = 10V		200	400	ns
		V _{DD} = 15V		160	320	ns
t _{TLH} , t _{THL}	Transition Time Carry Out and Decode Out Lines t _{TLH}	V _{DD} = 5V		200	360	ns
		V _{DD} = 10V		100	180	ns
		V _{DD} = 15V		80	130	ns
	t _{THL}	V _{DD} = 5V		100	200	ns
		V _{DD} = 10V		50	100	ns
		V _{DD} = 15V		40	80	ns
f _{CL}	Maximum Clock Frequency	V _{DD} = 5V V _{DD} = 10V V _{DD} = 15V	} Measured with Respect to Carry Output Line	1.0	2	MHz
		2.5		5	MHz	
		3.0		6	MHz	
t _{WL} , t _{WH}	Minimum Clock Pulse Width	V _{DD} = 5V		125	250	ns
		V _{DD} = 10V		45	90	ns
		V _{DD} = 15V		35	70	ns
t _{rCL} , t _{fCL}	Clock Rise and Fall Time	V _{DD} = 5V			20	μs
		V _{DD} = 10V			15	μs
		V _{DD} = 15V			5	μs
t _{SU}	Minimum Clock Inhibit Data Setup Time	V _{DD} = 5V		120	240	ns
		V _{DD} = 10V		40	80	ns
		V _{DD} = 15V		32	65	ns
C _{IN}	Average Input Capacitance			5	7.5	pF

AC Electrical Characteristics*

$T_A = 25^\circ\text{C}$, $C_L = 50\text{ pF}$, $R_L = 200\text{ k}$, t_{rCL} and $t_{fCL} = 20\text{ ns}$, unless otherwise specified

Symbol	Parameter	Conditions	Min	Typ	Max	Units
RESET OPERATION						
t_{PHL} , t_{PLH}	Propagation Delay Time Carry Out Line	$V_{DD} = 5\text{V}$ $V_{DD} = 10\text{V}$ $V_{DD} = 15\text{V}$		415 160 130	800 320 250	ns ns ns
	Carry Out Line	$V_{DD} = 5\text{V}$ $V_{DD} = 10\text{V}$ $V_{DD} = 15\text{V}$	} $C_L = 15\text{ pF}$	240 85 70	480 170 140	ns ns ns
	Decode Out Lines	$V_{DD} = 5\text{V}$ $V_{DD} = 10\text{V}$ $V_{DD} = 15\text{V}$		500 200 160	1000 400 320	ns ns ns
t_w	Minimum Reset Pulse Width	$V_{DD} = 5\text{V}$ $V_{DD} = 10\text{V}$ $V_{DD} = 15\text{V}$		200 70 55	400 140 110	ns ns ns
t_{REM}	Minimum Reset Removal Time	$V_{DD} = 5\text{V}$ $V_{DD} = 10\text{V}$ $V_{DD} = 15\text{V}$		75 30 25	150 60 50	ns ns ns

*AC Parameters are guaranteed by DC correlated testing.

Timing Diagrams

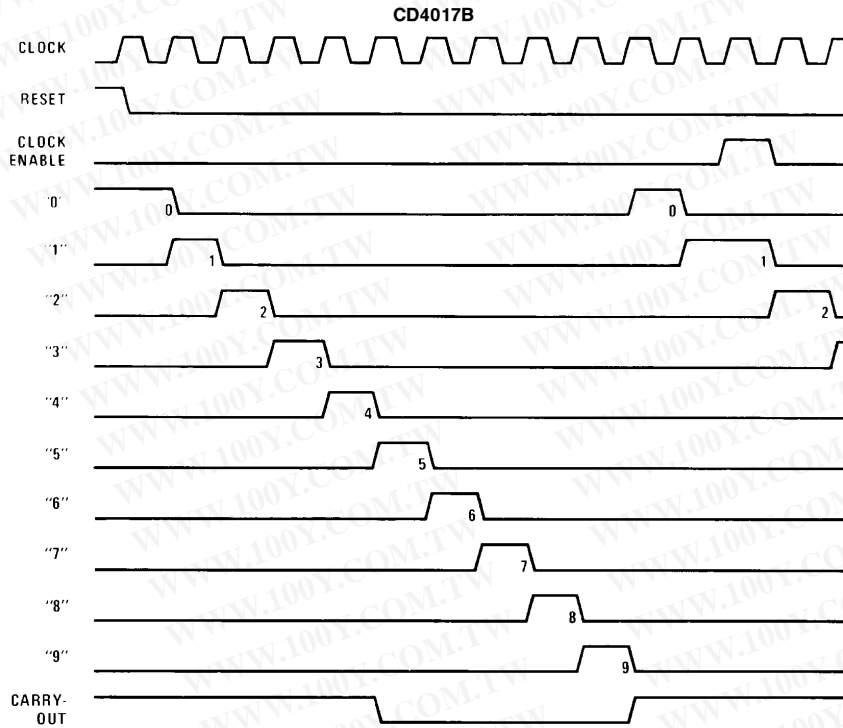

TL/F/5950-3

Timing Diagrams (Continued)

CD4022B

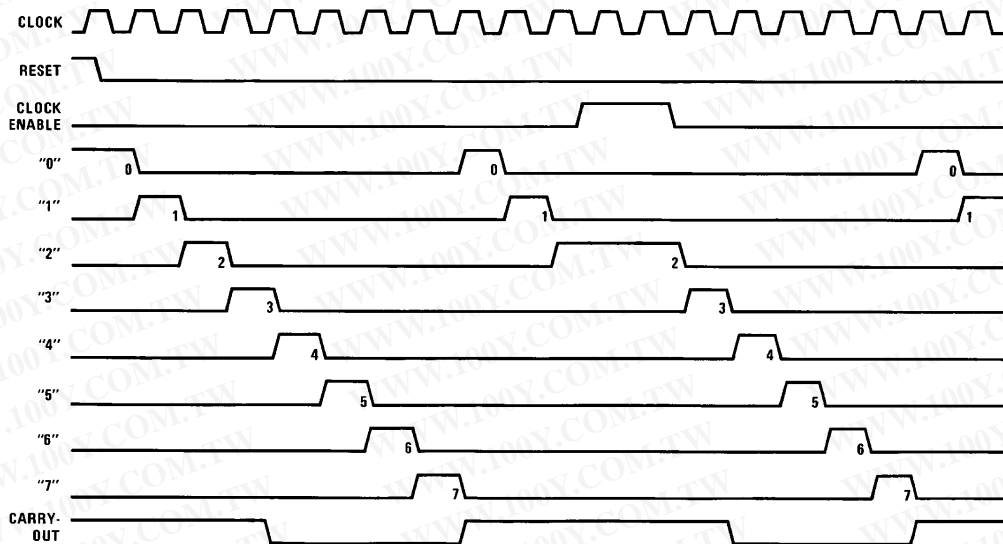

TL/F/5950-4

Physical Dimensions inches (millimeters)

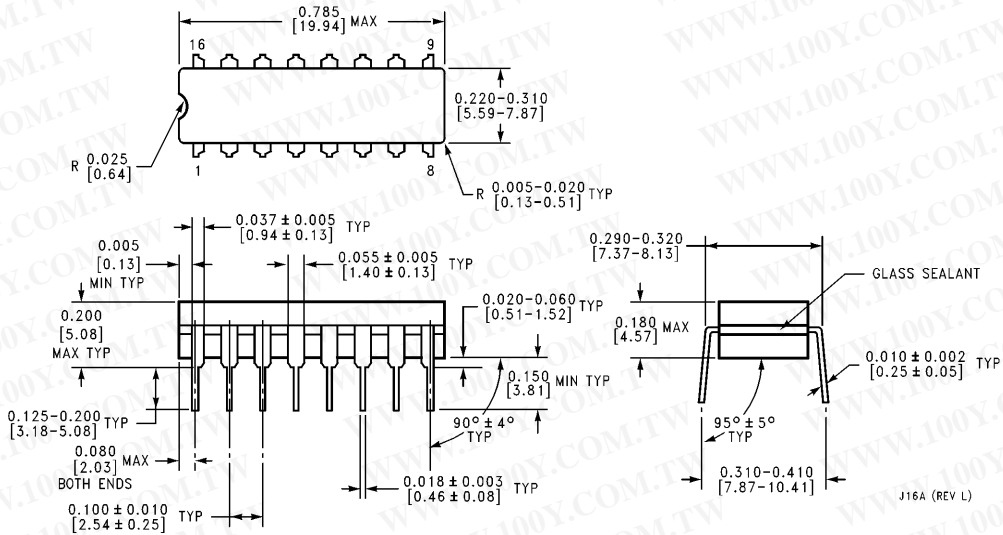

Ceramic Dual-In-Line Package (J)
Order Number CD4017BMJ, CD4017BCJ, CD4022BMJ, CD4022BCJ
NS Package Number J16A

Physical Dimensions inches (millimeters) (Continued)

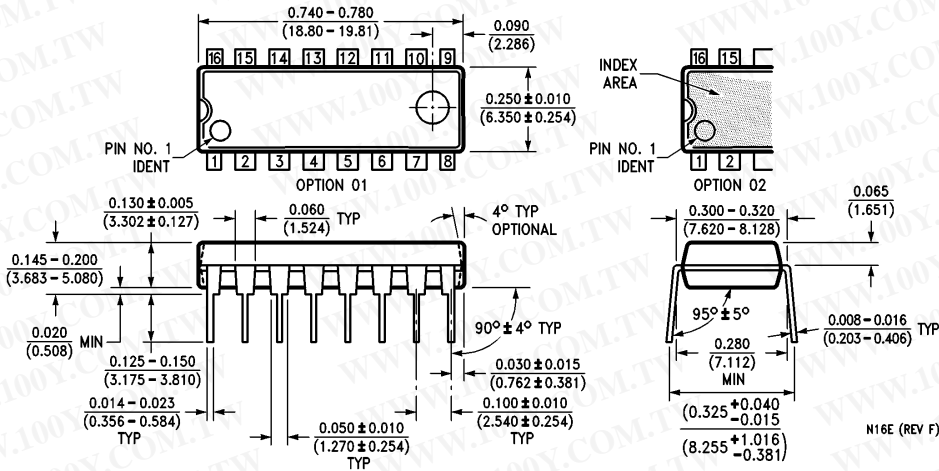

Molded Dual-In-Line Package (N)
Order Number CD4017BMN, CD4017BCN, CD4022BMN, CD4022BCN
NS Package Number N16E

LIFE SUPPORT POLICY

NATIONAL'S PRODUCTS ARE NOT AUTHORIZED FOR USE AS CRITICAL COMPONENTS IN LIFE SUPPORT DEVICES OR SYSTEMS WITHOUT THE EXPRESS WRITTEN APPROVAL OF THE PRESIDENT OF NATIONAL SEMICONDUCTOR CORPORATION. As used herein:

1. Life support devices or systems are devices or systems which, (a) are intended for surgical implant into the body, or (b) support or sustain life, and whose failure to perform, when properly used in accordance with instructions for use provided in the labeling, can be reasonably expected to result in a significant injury to the user.
2. A critical component is any component of a life support device or system whose failure to perform can be reasonably expected to cause the failure of the life support device or system, or to affect its safety or effectiveness.

