

4,1/2 位二視窗背光顯示, RS232 電腦介面附軟體

電阻:20/200/2K/20K/200K/2M/10M Ω \pm (0.5% + 3dgt)

電容:2000p/20n/200n/2000nF/20u/200u/2000u/20mF

電感:2000u/20m/200m/2000mH/20H/200H/2000H/20000H

測試頻率:120Hz/1KHz 選擇

串並聯等效電路選擇 PLA/SER

測試參數: D/Q/R 選擇 (副顯示)

TOL 測試: 誤差正負 % 值

設定高低值,相對值,誤差 % 值

SIZE:192H*91W*53D/mm

勝特力材料 886-3-5753170
勝特力电子(上海) 86-21-54151736
勝特力电子(深圳) 86-755-83298787
[Http://www.100y.com.tw](http://www.100y.com.tw)

20000 Counts LCR Meter

Dual Display Auto-Ranging

Outstanding Features:

- **Basic accuracy:**
 - 0.5% for Resistance
 - 0.7% for Inductance, Capacitance
- **Dual Displays** provide quick tested results readouts, with L.C.R. Display values up to 19999 counts and Q.D.R. display values up to 9999 counts
- **Excellent resolutions:**
 - Resistance up to 0.001 Ω
 - Inductance Capacitance up to 0.1uH/0.1pF
- **Provided up to 4 testing parameters:**
 - Ls+(Q,D,Rs), Lp+(Q,D,Rp)
 - Cs+(Q,D,Rs), Cp+(Q,D,Rp)
- **Auto-Power Off function:**
 - To conserve battery life for longer use.
- **Fuse detection function:**
 - To inform that the fuse is open or damaged.
- **PC communication port:**
 - Provided optical standard RS-232.
- **External DC Adapter functions:**
 - Use of a DC adapter can also serve to disable Auto Power Off function.

Specifications:

Display:

- L\C\R—4½ digits, maximum reading of 19999.
- Q\D\R—4 digits, maximum reading of 9999. (Auto range).

Parameter Measurement:

- Ls+(Q,D,Rs), Lp+(Q,D,Rp)
- Cs+(Q,D,Rs), Cp+(Q,D,Rp)

Overload: "OL" is display.

Test Frequency: 1KHz and 120Hz.

Range Mode: Auto and Manual.

Auto Power Off:

The meter key switch inactive for more than 5 minutes, press power key to resume operation.

Measurement rate: Approx. 1 time per second, nominal.

Power Requirement:

- (1). Single standard 9-volt battery.
(NEDA 1604, IEC 6F22 006P)
- (2). External DC Adapter 12Vmin to 15Vmax / 50mA.
(optional)

Overload Protection: 0.1A/250V fast below fuse.

Dimensions: 192mm(H) x 91mm(W) x 52.5mm(D).

Weight: 365g. (including accessories)

Model: 41R



勝特力材料 886-3-5753170
勝特力电子(上海) 86-21-54151736
勝特力电子(深圳) 86-755-83298787
[Http://www.100y.com.tw](http://www.100y.com.tw)

(4) RS-232 Output Chart for Second Display :

| range | Q / D | R (Rs=100Ω) | R (Rs=1KΩ,10KΩ) | R (Rs=100KΩ) |
|-------|-------|----------------|--------------------|-----------------|
| 1 | 999.9 | 99.99Ω | 99.99Ω | X |
| 2 | 99.99 | 999.9Ω | 999.9Ω | 999.9Ω |
| 3 | 9.999 | 9.999KΩ | 9.999KΩ | 9.999KΩ |
| 4 | .9999 | 99.99KΩ | 99.99KΩ | 99.99KΩ |
| 5 | X | X | 999.9KΩ | 999.9KΩ |

(5) FORMULA :

$$R_p = R_s(1+Q^2)$$

$$C_p = C_s[1/(1+D^2)]$$

$$C_s = C_p(1+D^2)$$

$$L_p = L_s[1+(1/Q^2)]$$

$$L_s = L_p[Q^2/(1+Q^2)]$$

勝特力材料 886-3-5753170
 勝特力电子(上海) 86-21-54151736
 勝特力电子(深圳) 86-755-83298787
[Http://www.100y.com.tw](http://www.100y.com.tw)

General specification

- Display:**
- 4 1/2 digit liquid crystal display (LCD).
- Overload indication:**
- “ OL” display.
- Low battery indication:**
- the “” is displayed when the battery voltage drops below the operating Level, and cancel all the memorized values to store into EEPROM .(included SET values)
- Measurement rate:**
- one time per second, nominal.
- Operating environment:**
- 0°C to 50°C at < 80 %RH.
- Storage environment:**
- -20°C to 60°C at 0 to 80 %RH. With battery removed from meter.
- Power:**
- single standard 9-volt battery, NEDA 1604, JIS 006P,IEC 6F22.
- External power:**
- minimum 12V, maximum 15V, and at least minimum 50mA.
- Auto-power:**
- As the “APO” is displayed on the LCD, the meter will shut down by itself if unused for about 10 minutes, press the power key to resume power-on mode. The meter will cancel auto power off function when RS232 , Max, and external power are used.
- FUSE warning:**
- Damaged or open fuse indicator.
- Note:**
- The microprocessor of the meter can self-detect if its fuse is either open or damaged. The LCD will display the symbol “FUSE” and an audible beep will sound continuously.
- Dimensions:**
- 19.2cm (Height), 9.1cm (width), and 5.25cm (thickness).
- Weights:**
- about 365g (including battery and holster).
- Accessories:**
- A pair of test leads, manual instruction, (9V battery and spare fuse in the meter).

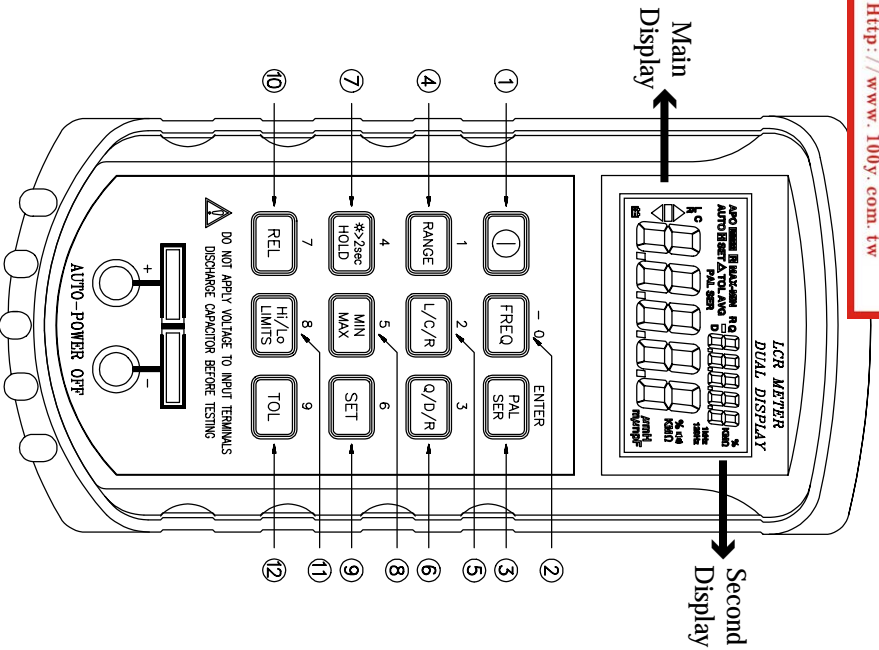

(3) RS-232 Output Chart for Main Display :

| range | Rs | R | | | L | | | Rs | C | |
|-------|-------|------------|----------|----------|-------|----------|----------|----|---|--|
| | | 1KHz/120Hz | 1KHz | 120Hz | | 1KHz | 120Hz | | | |
| 0 | 100Ω | 20.000Ω | 2000.0μH | 20.000mH | 100KΩ | 2000.0pF | 20.000nF | | | |
| 1 | 100Ω | 200.00Ω | 20.000mH | 200.00mH | 100KΩ | 20.000nF | 200.00nF | | | |
| 2 | 100Ω | 2000.0Ω | 200.00mH | 2000.0mH | 10KΩ | 200.00nF | 2000.0nF | | | |
| 3 | 1KΩ | 20.000KΩ | 2000.0mH | 20.000H | 1KΩ | 2000.0nF | 20.000μF | | | |
| 4 | 10KΩ | 200.00KΩ | 20.000H | 200.00H | 100Ω | 20.000μF | 200.00μF | | | |
| 5 | 100KΩ | 2000.0KΩ | 200.00H | 2000.0H | 100Ω | 200.00μF | 2000.0μF | | | |
| 6 | 100KΩ | 10.000MΩ | 1000.0H | 10000H | 100Ω | 2000.0μF | 20.000mF | | | |

26. LSD
27. Range for Q value , 9 : OL
28. S(SET) / _(normal)
29. F(FUSE) / _(normal)
30. H(HOLD) / _(normal)
31. R(Present value) / M(Maximum value) /
I(Minimum value) / X(Max-Min value) /
A(Average value) / _(normal)
32. R(REL) / S(REL SET) / _(normal)
33. L(LIMITS) / _(normal)
34. T(TOL) / S(TOL SET) / _(normal)
35. B(Backlight) / _(normal)
36. A(Adapter insert) / _(normal)
37. B(Low Battery) / _(normal)
38. CR (ASCII : 0DH)
39. nl(LF) (ASCII : 0AH)

勝特力材料 886-3-5753170
 勝特力电子(上海) 86-21-54151736
 勝特力电子(深圳) 86-755-83298787
[Http://www.100y.com.tw](http://www.100y.com.tw)

PANEL ILLUSTRATION



| | |
|--------------|--|
| APO | :Auto power off enable annunciator |
| RS232 | :Communication is activated annunciator |
| R | :Recording mode annunciator |
| MAX | :Maximum reading annunciator |
| MIN | :Minimum reading annunciator |
| AVG | :Average reading annunciator |
| AUTO | :Autoranging indicator |
| H | :Data hold annunciator |
| SET | :Set mode annunciator |
| Δ | :Relative mode annunciator |
| TOL | :Tolerance mode annunciator |
| PAL | :Parallel mode annunciator |
| SER | :Series mode annunciator |
| D | :Dissipation factor annunciator |
| Q | :Quality factor annunciator |
| R | :Parallel or Series Resistance annunciator |
| % | :Tolerance (percentage) annunciator |
| 1KHz | :Frequency annunciator |
| 120Hz | :Frequency annunciator |
| LCR | :L, C or R function annunciator |

- ▲ :Hi limits annunciator, Tolerance high annunciator
- ▼ :Lo limits annunciator, Tolerance low annunciator
- 🔋 :Indicates the battery power is weakening
-) :Beeper tone indicator for tolerance mode
- MKΩ :Resistance (Ohm) annunciator
- umH :Inductance (Henry) annunciator
- munpF :Capacitance(Fara) annunciator

勝特力材料 886-3-5753170
 勝特力电子(上海) 86-21-54151736
 勝特力电子(深圳) 86-755-83298787
[Http://www.100y.com.tw](http://www.100y.com.tw)

1. L / C / R
2. Q / D / R
3. A(1KHz) / B(120Hz)
4. P(PAL) / S(SER)
5. A(AUTO) / M(MENU)
6. 0 / 1: Main Display MSD,
8: while changing range ,
9: OL
7. 6~10 : Main Display Data
- 8.
- 9.
10. LSD
11. Main Display Range
12. MSD
13. 12~15 : Second Display Data
- 14.
15. LSD
16. Second Display Range , 9: OL
17. Sequence 0~9 cycling
18. MSD
19. 18~21 : D value
- 20.
21. LSD
22. Range for D value , 9 : OL
23. MSD
24. 23~26 : Q value
- 25.

SPECIFICATIONS

CAPACITANCE :

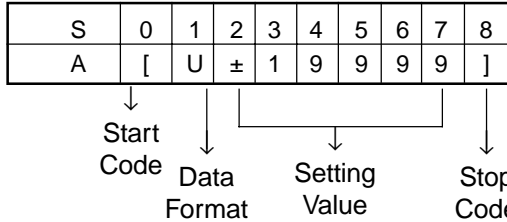

勝特力材料 886-3-5753170
 勝特力电子(上海) 86-21-54151736
 勝特力电子(深圳) 86-755-83298787
[Http://www.100y.com.tw](http://www.100y.com.tw)

[U±19999] : REL SET setting value

[V±19999] : Limits Hi setting value

[W±19999] : Limits Lo setting value

[X±19999] : TOL SET setting value

[Y±19999] : TOL SET Hi setting value

[Z±19999] : TOL SET Lo setting value

After receiving of setting data from PC (U/V/W/X/Y/Z), and will send out the receiving data again then it is convenient for PC to check the accuracy of data output are total 7 digits.

d.Command [BXXXXXX]: Exit the SETUP mode

(2) Read Data

Command N: Read Meter current data and status.

Data format: There are 39 ASCII code.

The Main Display data just send L/C/R data that don't process before (like the data before REL).

The Second Display data is the same as Main.

Test Frequency 120Hz

| Range | Min. | Max. | Cx | DF | Note |
|--------|-------|----------|--------------------------------|--|------------------|
| 20mF | 1μF | 10.000mF | ±(5.0% rdg +5counts) DF<0.1 | ±(10% rdg + 100/Cx + 5 counts) DF<0.1 | after short cal. |
| 2000μF | 10nF | 1999.9μF | ±(1.0% rdg +5counts) DF<0.1 | ±(2.0% rdg + 100/Cx + 5 counts) DF<0.1 | after short cal. |
| 200μF | 10nF | 199.99μF | ±(0.7% rdg +3counts) DF<0.5 | ±(0.7% rdg + 100/Cx + 5counts) DF<0.5 | - |
| 20μF | 1nF | 19.999μF | ±(0.7% rdg +3counts) DF<0.5 | ±(0.7% rdg + 100/Cx + 5counts) DF<0.5 | - |
| 2000nF | 100pF | 1999.9nF | ±(0.7% rdg +3counts) DF<0.5 | ±(0.7% rdg + 100/Cx + 5counts) DF<0.5 | - |
| 200nF | 10pF | 199.99nF | ±(0.7% rdg +5counts) DF<0.5 | ±(0.7% rdg + 100/Cx + 5counts) DF<0.5 | after open cal. |
| 20nF | 1pF | 19.999nF | ±(1.0% rdg +5counts) DF<0.1 | ±(2.0% rdg + 100/Cx + 5counts) DF<0.1 | after open cal. |

Test Frequency 1KHz

| Range | Min. | Max. | Cx | DF | Note |
|--------------|-------|----------------|---|---|------------------|
| 2000 μ F | 100nF | 1000.0 μ F | $\pm(5.0\% \text{ rdg}+5\text{counts})$ DF<0.1 | $\pm(10\% \text{ rdg} + 100/\text{Cx} + 5 \text{ counts})$ DF<0.1 | after short cal. |
| 200 μ F | 10nF | 199.99 μ F | $\pm(1.0\% \text{ rdg}+3\text{counts})$ DF<0.5 | $\pm(2.0\% \text{ rdg} + 100/\text{Cx} + 5\text{counts})$ DF<0.5 | after short cal. |
| 20 μ F | 1nF | 19.999 μ F | $\pm(0.7\% \text{ rdg}+3\text{counts})$ DF<0.5 | $\pm(0.7\% \text{ rdg} + 100/\text{Cx} + 5\text{counts})$ DF<0.5 | - |
| 2000nF | 100pF | 1999.9nF | $\pm(0.7\% \text{ rdg}+3\text{counts})$ DF<0.5 | $\pm(0.7\% \text{ rdg} + 100/\text{Cx} + 5\text{counts})$ DF<0.5 | - |
| 200nF | 10pF | 199.99nF | $\pm(0.7\% \text{ rdg}+5\text{counts})$ DF<0.5 | $\pm(0.7\% \text{ rdg} + 100/\text{Cx} + 5\text{counts})$ DF<0.5 | - |
| 20nF | 1pF | 19.999nF | $\pm(0.7\% \text{ rdg}+5\text{counts})$ DF<0.1 | $\pm(0.7\% \text{ rdg} + 100/\text{Cx} + 5\text{counts})$ DF<0.1 | after open cal. |
| 2000pF | 0.1pF | 1999.9pF | $\pm(1.0\% \text{ rdg}+5\text{counts})$ DF<0.1 | $\pm(2.0\% \text{ rdg} + 100/\text{Cx} + 5\text{counts})$ DF<0.1 | after open cal. |

RS-232 Command Table

Use IR as the interface of Data transmission, and use external computer to start RS-232 functions.

RS-232 Interface Parameter :

Baud rate : 1200

Parity check : EVEN

Data bits : 7

Stop bits : 1

(1) Setup Selections

a. Command S: Meter will enter the Setup mode and

return "SETUP READY.x".

(x:firmware version)

b. Command

[E](L/C/R)(Q/D/R)(P/S)(A/B)(A/M)(0~6):

Main function change

(L/C/R): L, C or R test function

(Q/D/R): Q, D or R

(P/S): P-PAL / S-SER

(A/B): A - 1KHz / B - 120Hz

(A/M): A - AUTO / M - MANUAL

(0~6): Manual range

c. Command [A-AAAAA]: Default change

MAINTENANCE

WARNING

Remove test leads before changing battery or fuse or performing any servicing.

Battery Replacement

Power is supplied by a 9 volt "transistor" battery. (NEDA 1604, IEC 6F22). The "  " appears on the LCD display when replacement is needed. To replace the battery, remove the two screws from the back of the meter and lift off the battery case. Remove the battery from battery contacts.

Fuse Replacement

The LCD display the symbol "FUSE" and an audible beep will sound. Replace fuse only with the original type 100mA/250V, fast acting fuse.

Cleaning

Periodically wipe the case with a damp cloth and detergent, do not use abrasives or solvents.

勝特力材料 886-3-5753170
 胜特力电子(上海) 86-21-54151736
 胜特力电子(深圳) 86-755-83298787
[Http://www.100y.com.tw](http://www.100y.com.tw)

INDUCTANCE :

Test Frequency 120Hz

| Range | Min. | Max. | Lx (DF<0.5) | DF (DF<0.5) | Note |
|--------|-------|----------|----------------------------------|--------------------------------|------------------|
| 20000H | 1H | 10000H | Not specified | Not specified | - |
| 2000H | 100mH | 1999.9H | ±(1.0% rdg + Lx/10000 + 5counts) | ±(2.0% rdg + 100/Lx + 5counts) | after open cal. |
| 200H | 10mH | 199.99H | ±(0.7% rdg + Lx/10000 + 5counts) | ±(1.2% rdg + 100/Lx + 5counts) | - |
| 20H | 1mH | 19.999H | ±(0.7% rdg + Lx/10000 + 5counts) | ±(1.2% rdg + 100/Lx + 5counts) | - |
| 2000mH | 100µH | 1999.9mH | ±(0.7% rdg + Lx/10000 + 5counts) | ±(1.2% rdg + 100/Lx + 5counts) | - |
| 200mH | 10µH | 199.99mH | ±(1.0% rdg + Lx/10000 + 5counts) | ±(3.0% rdg + 100/Lx + 5counts) | after short cal. |
| 20mH | 1µH | 19.999mH | ±(2.0% rdg + Lx/10000 + 5counts) | ±(10% rdg + 100/Lx + 5counts) | after short cal. |

Test Frequency 1KHz

| Range | Min. | Max. | Lx (DF<0.5) | DF (DF<0.5) | Note |
|--------|-------|----------|---|---|-----------------|
| 2000H | 100mH | 1000.0H | Not specified | Not specified | - |
| 200H | 10mH | 199.99H | $\pm(1.0\% \text{ rdg} + \text{Lx}/10000+5\text{counts})$ | $\pm(1.2\% \text{ rdg} + 100/\text{Lx} + 5\text{counts})$ | after open cal |
| 20H | 1mH | 19.999H | $\pm(0.7\% \text{ rdg} + \text{Lx}/10000+5\text{counts})$ | $\pm(1.2\% \text{ rdg} + 100/\text{Lx} + 5\text{counts})$ | - |
| 2000mH | 100μH | 1999.9mH | $\pm(1.0\% \text{ rdg} + \text{Lx}/10000+5\text{counts})$ | $\pm(1.2\% \text{ rdg} + 100/\text{Lx} + 5\text{counts})$ | - |
| 200mH | 10μH | 199.99mH | $\pm(0.7\% \text{ rdg} + \text{Lx}/10000+5\text{counts})$ | $\pm(1.2\% \text{ rdg} + 100/\text{Lx} + 5\text{counts})$ | - |
| 20mH | 1μH | 19.999mH | $\pm(1.2\% \text{ rdg} + \text{Lx}/10000+5\text{counts})$ | $\pm(5.0\% \text{ rdg} + 100/\text{Lx} + 5\text{counts})$ | after short cal |
| 2000μH | 0.1μH | 1999.9μH | $\pm(2.0\% \text{ rdg} + \text{Lx}/10000+5\text{counts})$ | $\pm(10\% \text{ rdg} + 100/\text{Lx} + 5\text{counts})$ | after short cal |

⑪ Hi/Lo LIMITS

Press "Hi/Lo LIMITS" to enter the Hi/Lo LIMITS mode, and change to manual range mode, the original Hi/LO LIMITS value and annunciators "▲" "▼" appear in the same time individually.

When the input exceeds Hi limits, the "▲" is blinking and emits a continuous tone. When the input goes below the Lo limits, the "▼" is blinking and the beeper emits a pulse tone. This warns users that out of setting ranges, press "Hi/Lo LIMITS" again to exit this mode.

In additions, the meter will ignore and not to record if overload ("OL") situation happens in the comparative processes or in the capacitance range ≤ 50 counts.

⑫ TOL

Press "TOL" to enter the tolerance mode, and change to manual range mode automatically, the original preset standard value and annunciators "TOL" appear in the same time individually. How to set standard value please refer to SET in this manual. When entering TOL mode, the Main display is the present value and the second display is tolerance value.

There are 4 preset values in the TOL mode for instant use, just to press TOL again to cycle through 1%, 5%, 10%, 20%, then back to the present. When entering the TOL mode, and the annunciator "▲" "▼" will appear in the same time, when the input exceeds Hi limits, the "▲" is blinking and also emits a continuous tone. When the Input goes below the LO limits, the "▼" is blinking and the beeper emits a pulse tone. This warns users that out of setting ranges.

The standard value can be set by SET function, please refer to SET setting in this manual. When standard value have set, and press "TOL" then press "SET" to use preset TOL setting.

In additions , the meter will ignore and not to record if overload ("OL") situation happens in the comparative processes or in the capacitance range ≤ 50 counts. Press "TOL" 2 sec to exit this function.

8. Data setting :

When using the character on the nameplate to input data, the previous setting will appear, and the place that waits to be entered will flash. INPUT starts from the largest digit to enter, the largest digit only 1, In that case the original setting will flash. The original setting is 0, and the bottom part of seven segments will flash. Press " 1 " is 1, press any keys is 0, press " ENTER" to exit without change. TOL Hi / Lo Limits setting without largest digit. There is no annunciator flashing After entering 5 digits, In the mean time enters + / - symbols, press "0" to change + / - symbols, press other keys to input + symbol.

* Caution: Press " ENTER", emit two beeps, the data store in volatile storage. The data will store in nonvolatile storage region while the meter power off. In this mode the automatic power-off feather is disabled.

⑩ REL Relative mode (only Main display)

Press "REL" key to the Relative mode. The displayed reading is stored as a reference value, the display is zeroed and annunciator "Δ" is displayed. Press REL key again to exit the Relative mode.

For example: the displayed reading is 100.0, then press REL to store as a reference value, and the display become zero, to store 100.0 as a standard reference value, if our input signal is 99.5, then the reading will be 99.5-100.0 that equals -0.5.

The user (see "SET" in this manual can also set the relative value). When the desired relative value has been entered, press REL key to enter the Relative mode, and press SET key to use Relative value as a reference value. Press REL again to exit the relative Mode.

RESISTANCE :

| Range | Minimum | Maximum | Test Freq. 120Hz | Test Freq. 1kHz | Note |
|-------|---------|----------|------------------------|------------------------|------------------|
| 10MΩ | 1kΩ | 10.000MΩ | ±(2.0% rdg + 8 counts) | ±(2.0% rdg + 8 counts) | after open cal. |
| 2MΩ | 100Ω | 1.9999MΩ | ±(0.5% rdg + 5 counts) | ±(0.5% rdg + 5 counts) | after open cal. |
| 200kΩ | 10Ω | 199.99kΩ | ±(0.5% rdg + 3 counts) | ±(0.5% rdg + 3 counts) | - |
| 20kΩ | 1Ω | 19.999kΩ | ±(0.5% rdg + 3 counts) | ±(0.5% rdg + 3 counts) | - |
| 2kΩ | 100mΩ | 1.9999kΩ | ±(0.5% rdg + 3 counts) | ±(0.5% rdg + 3 counts) | - |
| 200Ω | 10mΩ | 199.99Ω | ±(0.8% rdg + 5 counts) | ±(0.8% rdg + 5 counts) | after short cal. |
| 20Ω | 1mΩ | 19.999Ω | ±(1.2% rdg + 8 counts) | ±(1.2% rdg + 8 counts) | after short cal. |

Note: In 20Ω range, effective readings must over 20 counts.

Remark

1. Q value is the reciprocal of DF.
2. The specification is based on the testing sockets (clips) performed on the meter.
3. L(C) x indicates the readings of inductance (capacitance) on the display.
E.g.: inductance (capacitance)=18.888H(F) then L (C) x=18888.

勝特力材料 886-3-5753170
勝特力电子(上海) 86-21-54151736
勝特力电子(深圳) 86-755-83298787
[Http://www.100y.com.tw](http://www.100y.com.tw)

4. OPEN, SHORT calibration :

Press "SET", LCD will display CAL OPEn, and press PAL/SER (ENTER), the program enters " OPEN " calibration, after completing the open. The LCD displays CAL SHrt, press PAL/SER (ENTER). The program enters Short calibration. If you do not want to proceed Short calibration, and press " SET " to exit. When LCD shows CAL SHrt, press PAL/SER (ENTER) key. The program enters "SHORT " calibration. And then back to normal situation.

5. Hi/Lo Limits setting:

Press "Hi/LO", LCD only shows ▲ flashing. The previous setting Hi will also appear and let user to do the modifications. When you input Lo setting value ,the annunciator ▼ is flashing. The previous setting Lo will also appear and let user to do the modifications. When the Lo setting value is greater than the Hi setting value, the LCD shows Err and back to the Hi setting mode. Please to enter the new Hi/Lo setting value.

6.TOL Hi/Lo Limits setting :

Press "TOL", LCD shows TOL flashing. The previous setting standard value will also appear and let user to do the modifications. When you input + TOL setting value, the annunciators "TOL" "▲" are flashing. The previous setting +TOL will also appear and let user to do the modifications. When you input -TOL setting value, the annunciators "TOL" "▼" are flashing. The previous setting - TOL will also appear and let user to do the modifications.

7. REL setting :

Press "REL", LCD shows D flashing. The previous standard setting value will also appear and let user to do the modifications.

⑧ Min/Max button

Press "Min/Max" to enter the Min/Max/Avg mode, and stop the auto shut down function. In Addition to power and hold key, the other keys cannot be activated. When the meter samples about 6 times, and then beeper will emit a sound. When a new Max/Min data being recorded and then beeper will emit 2 sounds.

Main display value (second display value) cycles through (Min/Max key) present value (parameter value) → Max value (parameter value) → Min value (parameter value) → Max value minus Min value (times to test) → The Average Value's display (times to test) .

The meter will ignore and not to record if overload ("OL") situation happens in the comparative processes or in the capacitance range ≤ 50 counts.

The Average Value's display is true average recording. It can save up to 3000 times, the "Avg" annunciator will flash when recording times reaching 2991 to 3000 times. When recording over 3000 times the Avg will stop to record and it will also display the average value on the LCD. The meter continues to record the Max/Min value.

Under the Max/Min function, press "HOLD" key to stop recording temporarily but store the former recording value in advance, press "HOLD" again to go on recording.

In order to prevent any mistakes or losses taken, you have to press 2 sec to exit the Max/Min function and cancel the original recordings.

⑨ SET

1. The "SET" can only be activated only before you have not used any other functions.
2. Press "SET" to enter the SET mode, and change to manual range mode automatically.
3. While in the SET function, the main display is cleared, the second display shows "SET" annunciators, LCD shows Δ , TOL, \blacktriangle , \blacktriangledown flashing .There are only 5 keys that you can use "Power", "SET", "REL", "Hi/Lo", "TOL" in this moment.

Operation Instruction

Cautions:

It is recommended that you read the safety and operation instructions before using the meter.

WARNING

Before taking any measurements, please isolate the UDT from the power supply.

To avoid electric shock, plug off the test leads from the meter before opening case and battery hatch.

Do not use the meter if test leads, alligator's clips and appearance look cracked and damaged, Please check periodically.

To avoid electric shock, discharge the circuits completely, before taking any measurements.

CAUTION

When it appears to have abnormal situations, such as you can not turn on the meter to operate.

1. It is normal situation when you can not turn on the meter after turning off the meter just for few seconds. Please wait a moment to turn it on again.
2. When you can not operate the meter normally, please turn off it and restart the meter.
3. There are two measuring concerns when it comes to measure under 0.5 ohms.
 - i. Use tidy alligator clips to clip the DUT(Device Under Test) reliably. Before taking any measurements, please make short-zeroing calibration to make sure impedance between test leads.
 - ii. The DUT(Device Under Test) must keep clean and should not have any oxidization existed or untidy phenomenon, which will affect accuracy.

① Auto Power-down

If unused for about 10 minutes, the meter will power-down automatically. Press ① button switches to resume power-on mode.

When the power is down, press ① button to turn on the meter. The operating condition return to what they were before the power was last turned off.

In the MIN MAX record mode, RS-232 communication mode or using DC power-adaptor auto-power down function is disabled automatically.

Continuous Measurement

In the power down mode, Push ① button 2 sec. Until the APO OFF annunciator appears. Will put the meter into the continuous measurement mode.

Power Switch

The ① button turns the meter on or off. In the microcomputer failure status press ① button until the meter off.

② FREQUENCY Select

Set the "FREQ" button switch to 120Hz or 1KHz according to the specimen to be test. Generally, the electrolytic capacitor is set to 120Hz. Others are set to 1kHz in general.

③ PARALLEL / SERIES mode

Set the "PAL SER" button switch to parallel or series measuring circuit mode. However, in the specimen having a high impedance in general, measurement is made in parallel equivalent circuit mode "PAL", while in the specimen having a low impedance, measurement is made in series equivalent circuit mode "SER".

④ RANGE Button

Press (RANGE) button to select the Manual Range mode and turn off the "AUTO" annunciator. (The meter remains in the range it was in when manual ranging was selected).

In the Manual Range mode. Each time you press (RANGE) button, the range (and the input range annunciator) increments, and a new value is displayed. To exit the Manual Range mode and return to autoranging, press and hold down (RANGE) button for 2 seconds. The "AUTO" annunciator turns back on.

⑤ L/C/R Function Button (only Main display)

The L/C/R key switch the measurement parameter in sequence L - C - R - L ..., the annunciator is indicated on LCD.

When the meter is turned on, it is set to the measurement parameter selected that was in use when the meter was last turned off.

⑥ Q/D/R Function Button (only Second display)

The Q/D/R key switch the measurement parameter in sequence Q - D - R - Q ..., the annunciator is indicated on LCD.

When the meter is turned on, it is set to the measurement parameter selected that was in use when the meter was last turned off.

⑦ HOLD.*>2sec

Press the "HOLD" key to enter the data hold mode, the "HOLD" annunciator is displayed.

When Hold mode is selected, the meter stops all further measurements. Press "HOLD" 2 sec to start backlit function, press this key for 2 sec to exit the Backlit function.

After starting the backlit for 1 minute, the Backlit function will exit by itself.

勝特力材料 886-3-5753170
勝特力电子(上海) 86-21-54151736
勝特力电子(深圳) 86-755-83298787
Http://www.100y.com.tw