

SL-series solid state input relay

- Plug-in input relay for 110...125 VDC voltages
- 100 mA maximum load current
- 0...60 VDC load voltage
- Secondary is conducting without input signal (NC)
- Works without logic supply (4 pole)
- For PLC input signal conditioning
- Immune to disturbances on signal lines
- Shielded signal cabling not required
- CE (EMC and LVD tested)
- Integrated status LED

勝特力材料 886-3-5753170
 勝特力电子(上海) 86-21-54151736
 勝特力电子(深圳) 86-755-83298787
[Http://www.100y.com.tw](http://www.100y.com.tw)

Block diagram

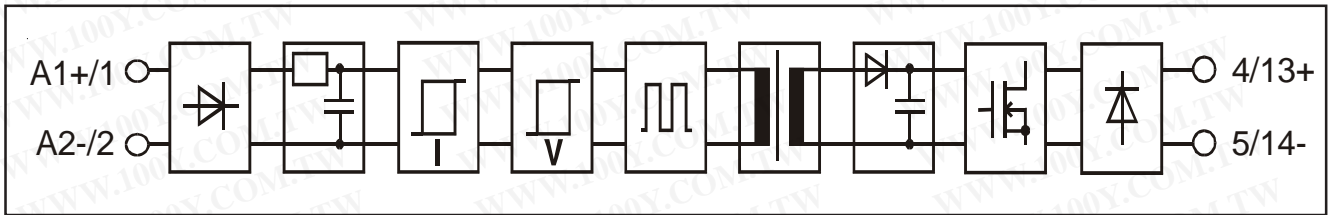

Specifications (at temperature of 25 °C)

Primary

Input voltage	nominal	110...125 VDC
Input current	typical	4 mA
Input current at nominal voltage	maximum	4,3 mA
Input voltage range (abs.)	minimum	95 VDC
	maximum	140 VDC
Input impedance	typical	31 kΩ
Switch-on voltage	typical	80 VDC
	maximum	95 VDC
Switch-off voltage	typical	60 VDC
	minimum	50 VDC
Noise immunity	typical	0,2 mJ

(On-state means that relay is on and secondary is not conducting.)

Secondary

Load voltage	minimum	0 VDC
	maximum	60 VDC
Load current	maximum	100 mA
Voltage drop at 30 mA load	typical	0,3 V
	maximum	0,5 V
Switch-on delay	typical	1 ms
	maximum	-
Switch-off delay	typical	1 ms
	maximum	-

Physical dimensions and other data

Breakdown voltage	minimum	4000 VAC rms
Resistance	minimum	10 ¹⁰ Ω
Material of casing	thermoplastic	UL 94 V-0
Weight	typical	40 g
Air/creepage distance	minimum	8 mm
Capacitance I/O	typical	3 pF

Color of casing: white

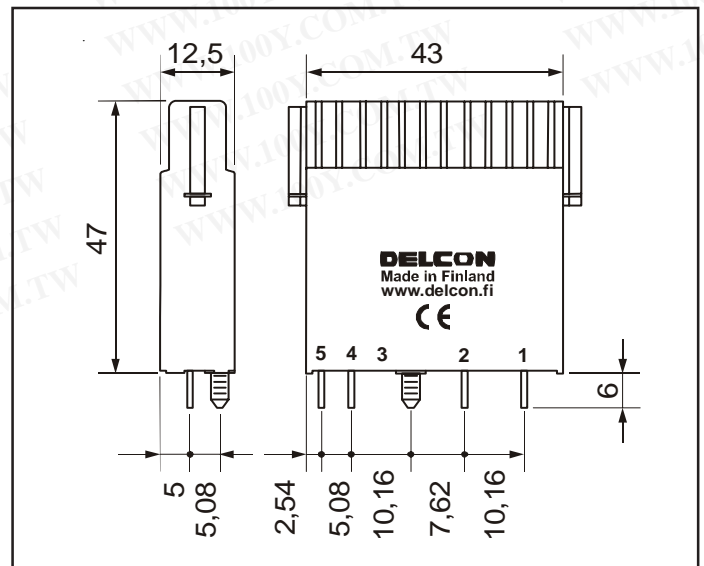

Dimensions in mm.

Temperature limitations

There are no limitation needs for this relay.

Temperature range:

Storage: -40 °C...+70 °C
Operation: -25 °C...+70 °C

勝特力材料 886-3-5753170
勝特力电子(上海) 86-21-54151736
勝特力电子(深圳) 86-755-83298787
[Http://www.100y.com.tw](http://www.100y.com.tw)

Derating when switching inductive loads

This relay is ment for PLC inputs and similar loads. A clamp diode must be used when swiching inductive loads.

Fusing

To protect relay against short circuit and overload a fast fuse with the correct rating for the load and the capacity of the relay should be chosen, for instance from the Wickman 193 range. Note that when overload current is not large it is possible that the fuse will not protect the relay because of the tolerance on the fuse rating.

Approvals



The relay fulfils EMC-directive 89/336/EEC requirements. Product has been tested according generic standards EN50081-2 and EN50082-2. The relay fulfils also requirements of the low voltage directive 73/23/EEC.

Guarantee

The solid state I/O relays and accessories made by Delcon Oy are guaranteed free from design and manufacturing defects for a period of three years from the shipping date. For electromechanical relays the guarantee is one year. The guarantee liability is limited to replacement of defective material and related shipping charges. Defective products must be returned to the factory for evaluation. This guarantee does not cover damage due to incorrect use or electrical overload.