

勝特力材料 886-3-5753170
 勝特力电子(上海) 86-21-54151736
 勝特力电子(深圳) 86-755-83298787
[Http://www.100y.com.tw](http://www.100y.com.tw)

MAXIM

Quad SPST CMOS Analog Switches

General Description

The MAX331, DG201A and DG211 are normally closed, quad single-pole-single-throw (SPST) analog switches. These CMOS switches can be continuously operated with power supplies ranging from $\pm 4.5V$ to $\pm 18V$. Maxim guarantees that these switches will not latch-up if the power supplies are disconnected with input signals still connected.

All three devices have guaranteed break-before-make switching. The MAX331 and DG201A differ with the DG211 primarily in switching speeds. The MAX331 and DG201A have a maximum turn-off time of 450ns and a maximum turn-on time of 600ns. The DG211 has a maximum turn-off time of 500ns and a maximum turn-on time of 1000ns.

Compared to the original manufacturer's products, Maxim's DG201A and DG211 consume significantly lower power, making them better suited for portable applications. By specifying the MAX331, the customer is guaranteed low power consumption units. Maxim has also eliminated the need for the third (V_L) power supply that is required for the operation of the original manufacturer's DG211.

Applications

- Winchester Disk Drives
- Test Equipment
- Communications Systems
- PBX, PABX
- Guidance and Control Systems
- Head up Displays
- Military Radios

Typical Operating Circuit

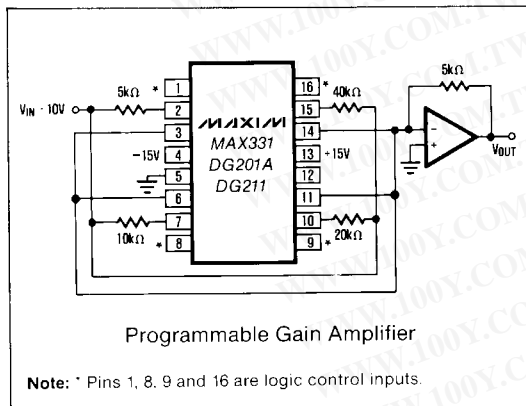

Features

- ◆ Improved 2nd Source! (See pages 3 and 5 for "MAXIM Advantage™")
- ◆ Guaranteed $\pm 4.5V$ to $\pm 18V$ Operation
- ◆ No V_L Supply Required
- ◆ Non-Latching with Supplies Turned-off and Input Signals Present
- ◆ CMOS and TTL Logic Compatible
- ◆ Monolithic, Low Power CMOS Design

Ordering Information

| PART | TEMP RANGE | PACKAGE |
|-----------|-----------------|-----------------------|
| MAX331MJE | -55°C to +125°C | 16 Lead Cerdip |
| DG201AAK | -55°C to +125°C | 16 Lead Cerdip |
| DG201ABK | -25°C to +85°C | 16 Lead Cerdip |
| DG201ACK | 0°C to +70°C | 16 Lead Cerdip |
| DG201ACJ | 0°C to +70°C | 16 Lead Plastic DIP |
| DG201ACSE | 0°C to +70°C | 16 Lead Small Outline |
| DG201C/D | 0°C to +70°C | Dice |
| DG211CJ | 0°C to +70°C | 16 Lead Plastic DIP |
| DG211CSE | 0°C to +70°C | 16 Lead Small Outline |
| DG211C/D | 0°C to +70°C | Dice |

Pin Configuration

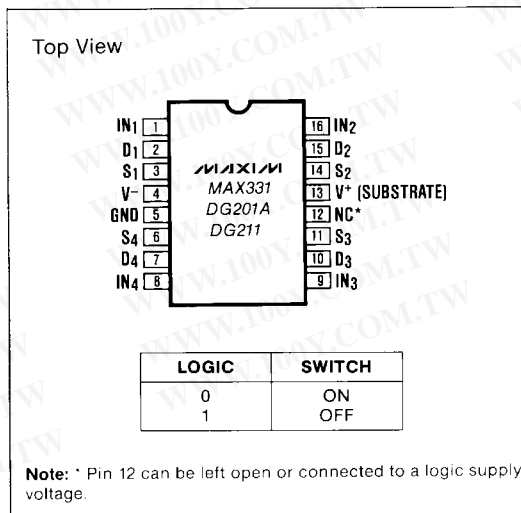

MAX331/DG201A/DG211

Quad SPST CMOS Analog Switches

MAX331/DG201A/DG211

ABSOLUTE MAXIMUM RATINGS (DG211)

| | |
|---|------------|
| V^+ to V^- | 40V |
| V_{IN} to Ground | V^-, V^+ |
| V_L to Ground | -0.3V, 25V |
| V_S or V_D to V^+ | 0, -40V |
| V_S or V_D to V^- | 0, 40V |
| V^+ to Ground | 25V |
| V^- to Ground | -25V |
| Current, Any Terminal Except S or D | 30mA |
| Continuous Current, S or D | 20mA |
| Peak Current, S or D (Pulsed at 1msec, 10% duty cycle max) | 70mA |

| | |
|--|-----------------|
| Storage Temperature | -65°C to +125°C |
| Operating Temperature | 0°C to +70°C |
| Power Dissipation (Note 1) | |
| 16 Pin Plastic DIP (Note 2) | 470mW |
| 16 Pin Small Outline (SE) (Note 3) | 400mW |

- Note 1:** Device mounted with all leads soldered to PC board.
Note 2: Derate 6.5mW/°C above +25°C.
Note 3: Derate 7mW/°C above +25°C.

Stresses listed under "Absolute Maximum Ratings" may be applied (one at a time) to devices without resulting in permanent damage. These are stress ratings only, and functional operation of the device at these or any other conditions above those indicated in the operational sections of the specifications is not implied. Exposure to absolute maximum ratings conditions for extended periods may affect device reliability.

ELECTRICAL CHARACTERISTICS (DG211)

($V^+ = +15V$, $V^- = -15V$, GND = 0V, $T_A = +25^\circ C$, unless otherwise noted)

| | PARAMETER | SYMBOL | TEST CONDITIONS | LIMITS | | | UNITS |
|---------------------------------------|-----------------------------------|-----------------------------------|---|-----------------|-----------------|---------|----------|
| | | | | MIN (Note 4) | TYP (Note 5) | MAX | |
| SWITCH | Analog Signal Range | V_{ANALOG} | | -15 | | 15 | V |
| | Drain-Source ON Resistance | $r_{DS(on)}$ | $V_D = \pm 10V, V_{IN} = 0.8V, I_S = 1mA$ | | 115 | 175 | Ω |
| | Source OFF Leakage Current | $I_{S(off)}$ | $V_{IN} = 2.4V$ $V_S = 14V, V_D = -14V$ $V_S = -14V, V_D = 14V$ | | 0.01 | 5.0 | nA |
| | Drain OFF Leakage Current | $I_{D(off)}$ | $V_{IN} = 2.4V$ $V_S = 14V, V_D = -14V$ $V_S = -14V, V_D = 14V$ | | 0.01 | 5.0 | |
| | Drain ON Leakage Current (Note 6) | $I_{D(on)}$ | $V_S = V_D = 14V, V_{IN} = 0.8V$ $V_S = V_D = -14V, V_{IN} = 0.8V$ | | 0.1 | 5.0 | |
| Input Current With Input Voltage High | I_{INH} | $V_{IN} = 2.4V$ $V_{IN} = 15V$ | | -1.0 | -0.0004 | μA | |
| Input Current With Input Voltage Low | I_{INL} | $V_{IN} = 0V$ | | -1.0 | -0.0004 | | |
| DYNAMIC | Turn-ON Time | t_{on} | See Switching Time Test Circuit $V_S = 2V, R_L = 1k\Omega, C_L = 35pF$ | | 460 | 1000 | ns |
| | Turn-OFF Time | t_{off1} t_{off2} | | | 360 | 500 | |
| | Source OFF Capacitance | $C_{S(off)}$ | $V_S = 0V, V_{IN} = 5V, f = 1MHz$ | | 5 | | pF |
| | Drain OFF Capacitance | $C_{D(off)}$ | $V_D = 0V, V_{IN} = 5V, f = 1MHz$ | | 5 | | |
| | Channel ON Capacitance | $C_{D-S(on)}$ | $V_D = V_S = 0V, V_{IN} = 0V, f = 1MHz$ | | 16 | | |
| | OFF Isolation (Note 7) | OIRR | $V_{IN} = 5V, R_L = 1k\Omega, C_L = 15pF,$ $V_S = 1VRMS, f = 100kHz$ | | 70 | | dB |
| Crosstalk (Channel to Channel) | CCRR | | | 90 | | | |
| SUPPLY | Positive Supply Current | I^+ | $V_{IN} = 0V$ and $2.4V$ | | 0.35 | 0.48 | mA |
| | Negative Supply Current | I^- | | | 0.30 | 0.48 | |
| | Logic Supply Current | I_L | | | 0.5 | 1.2 | |

Note 4: The algebraic convention whereby the most negative value is a minimum, and the most positive is a maximum, is used in this data sheet.

Note 5: Typical values are for DESIGN AID ONLY, not guaranteed nor subject to production testing.

Note 6: $I_{D(on)}$ is leakage from driver into "ON" switch.

Note 7: OFF Isolation = $20 \log \frac{V_S}{V_D}$, V_S = input to OFF switch, V_D = output.

The electrical characteristics above are a reproduction of a portion of Siliconix's copyrighted 1985 data book. This information does not constitute any representation by Maxim that Siliconix's products will perform in accordance with these specifications. The "Electrical Characteristics Table" along with descriptive excerpts from the original manufacturer's data sheet have been included in this data sheet solely for comparative purposes.



Quad SPST CMOS Analog Switches

- ◆ Significantly Reduced Power Consumption
- ◆ Third (Logic) Supply Not Required
- ◆ Fault Protected

ABSOLUTE MAXIMUM RATINGS (DG211) This device conforms to the Absolute Maximum Ratings on the adjacent page.

ELECTRICAL CHARACTERISTICS (DG211): Specifications below satisfy or exceed all "tested" parameters on adjacent page.

(V⁺ = +15V, V⁻ = -15V, GND = 0V, T_A = +25°C, unless otherwise noted)

| | PARAMETER | SYMBOL | TEST CONDITIONS | LIMITS | | | UNITS |
|--|--|---|---|-----------------|-----------------|------|-------|
| | | | | MIN (Note 4) | TYP (Note 5) | MAX | |
| SWITCH | Analog Signal Range | V _{ANALOG} | | -15 | | 15 | V |
| | Drain-Source ON Resistance | r _{DS(on)} | V _D = ±10V, V _{IN} = 0.8V, I _S = 1mA | | 115 | 175 | Ω |
| | Source OFF Leakage Current | I _{S(off)} | V _{IN} = 2.4V V _S = 14V, V _D = -14V V _S = -14V, V _D = 14V | -5.0 | 0.01 | 5.0 | nA |
| | Drain OFF Leakage Current | I _{D(off)} | V _{IN} = 2.4V V _S = 14V, V _D = -14V V _S = -14V, V _D = 14V | -5.0 | 0.01 | 5.0 | |
| | Drain ON Leakage Current (Note 6) | I _{D(on)} | V _S = V _D = 14V, V _{IN} = 0.8V V _S = V _D = -14V, V _{IN} = 0.8V | -5.0 | 0.1 | 5.0 | |
| Input Current With Input Voltage High | I _{INH} | V _{IN} = 2.4V V _{IN} = 15V | -1.0 | 0.0004 | 1.0 | μA | |
| INPUT | Input Current With Input Voltage Low | I _{INL} | V _{IN} = 0V | -1.0 | 0.0004 | | |
| DYNAMIC | Turn-ON Time | t _{on} | See Switching Time Test Circuit V _S = 2V, R _L = 1kΩ, C _L = 35pF | | 460 | 1000 | ns |
| | Turn-OFF Time | t _{off1} | | | 360 | 500 | |
| | | t _{off2} | | | 450 | | |
| | Source OFF Capacitance | C _{S(off)} | V _S = 0V, V _{IN} = 5V, f = 1MHz | | 5 | | pF |
| | Drain OFF Capacitance | C _{D(off)} | V _D = 0V, V _{IN} = 5V, f = 1MHz | | 5 | | |
| | Channel ON Capacitance | C _{D+S(on)} | V _D = V _S = 0V, V _{IN} = 0V, f = 1MHz | | 16 | | dB |
| | OFF Isolation (Note 8) | OIRR | V _{IN} = 5V, R _L = 1kΩ, C _L = 15pF, V _S = 1VRMS, f = 100kHz | | 70 | | |
| Crosstalk (Channel to Channel) | CCRR | | | 90 | | | |
| SUPPLY | Positive Supply Current | I ⁺ | V _{IN} = 0V and 2.4V | | 0.02 | 0.1 | mA |
| | Negative Supply Current | I ⁻ | | | 0.01 | 0.1 | |
| | Logic Supply Current | I _L | | | 0.0 | 0.0 | |
| | Power Supply Range for Continuous Operation | V _{OP} | | | ±4.5 | | |

Note 8: Electrical characteristics, such as ON Resistance, will change when power supplies, other than ±15V, are used.

MAX331/DG201A/DG211

MAX331/DG201A/DG211

Quad SPST CMOS Analog Switches

ABSOLUTE MAXIMUM RATINGS (MAX331, DG201A)

| | | |
|--|--|-----------------|
| Voltages Referenced to V ⁻ | Storage Temperature | -65°C to +150°C |
| V ⁺ | Power Dissipation (Note 2) | |
| GND | 16 Pin CERDIP (Note 3) | 900mW |
| Digital Inputs (Note 1), V _S , V _D | 16 Pin Plastic DIP (Note 4) | 470mW |
| -2V to (V ⁺ +2V) | 16 Pin Small Outline (SE) (Note 5) | 400mW |
| or 20mA, whichever occurs first | | |
| Current, Any Terminal Except S or D | Note 1: Signals on S _X , D _X , or I _{NX} exceeding V ⁺ or V ⁻ on Maxim's | |
| 30mA | MAX331 and DG201A will be clamped by internal diodes, | |
| Continuous Current, S or D | and are also internally current limited to 25mA. | |
| 20mA | Note 2: Device mounted with all leads soldered to PC board. | |
| Peak Current, S or D | Note 3: Derate 12mW/°C above +75°C. | |
| (Pulsed at 1msec, 10% duty cycle max.) | Note 4: Derate 6.5mW/°C above +25°C. | |
| 70mA | Note 5: Derate 7mW/°C above +25°C. | |
| Operating Temperature | | |
| DG201A (A Suffix) | | |
| -55°C to +125°C | | |
| (B Suffix) | | |
| -25°C to +85°C | | |
| (C Suffix) | | |
| 0°C to +70°C | | |
| MAX331MJE | | |
| -55°C to +125°C | | |

Stresses listed under "Absolute Maximum Ratings" may be applied (one at a time) to devices without resulting in permanent damage. These are stress ratings only, and functional operation of the device at these or any other conditions above those indicated in the operational sections of the specifications is not implied. Exposure to absolute maximum ratings conditions for extended periods may affect device reliability.

ELECTRICAL CHARACTERISTICS (DG201A)

(V⁺ = -15V, V⁻ = -15V, GND = 0V, T_A = +25°C, unless otherwise noted)

| | PARAMETER | SYMBOL | TEST CONDITIONS | LIMITS | | | | UNITS |
|-----------------------------------|---------------------------------------|---|---|---------|---------|-----------|---------|-------|
| | | | | DG201AA | | DG201AB,C | | |
| | | | | MIN | TYP | MAX | MIN | |
| SWITCH | Analog Signal Range | V _{ANALOG} | | -15 | 15 | -15 | 15 | V |
| | Drain-Source ON Resistance | r _{DS(on)} | V _D = ±10V, V _{IN} = 0.8V, I _S = 1mA | 115 | 175 | 115 | 200 | Ω |
| | Source OFF Leakage Current | I _{S(off)} | V _{IN} = 2.4V | 0.01 | 1.0 | 0.01 | 5.0 | nA |
| | Drain OFF Leakage Current | I _{D(off)} | V _S = 14V, V _D = -14V | -5.0 | -0.02 | | | |
| | | | V _S = -14V, V _D = 14V | | | 0.01 | 5.0 | |
| Drain ON Leakage Current (Note 8) | I _{D(on)} | V _S = -14V, V _{IN} = 0.8V | 0.1 | 1.0 | 0.1 | 5.0 | | |
| INPUT | Input Current With Input Voltage High | I _{INH} | V _{IN} = 2.4V | -1.0 | -0.0004 | -1.0 | -0.0004 | μA |
| | Input Current With Input Voltage Low | I _{INL} | V _{IN} = 15V | 0.003 | 1.0 | 0.003 | 1.0 | |
| DYNAMIC | Turn-ON Time | t _{on} | See Switching Time Test Circuit | 480 | 600 | 480 | 600 | ns |
| | Turn-OFF Time | t _{off1} | | 370 | 450 | 370 | 450 | |
| | Charge Injection | Q | C _L = 1000pF, V _{GEN} = 0V, R _{GEN} = 0Ω | 20 | | 20 | | pC |
| | Source OFF Capacitance | C _{S(off)} | V _S = 0V, V _{IN} = 5V | 5 | | 5 | | pF |
| | Drain OFF Capacitance | C _{D(off)} | | 5 | | 5 | | |
| | Channel ON Capacitance | C _{D(on)} + C _{S(on)} | V _D = V _S = 0V, V _{IN} = 0V | 16 | | 16 | | dB |
| | OFF Isolation | | V _{IN} = 5V, Z _L = 75Ω | 70 | | 70 | | |
| Crosstalk (Channel to Channel) | | V _S = 2.0V, f = 100kHz | 90 | | 90 | | | |
| SUPPLY | Positive Supply Current | I ⁺ | All Channels ON or OFF | 0.9 | 2 | 0.9 | 2 | mA |
| | Negative Supply Current | I ⁻ | | -1 | -0.3 | -1 | -0.3 | |

Note 6: The algebraic convention whereby the most negative value is a minimum, and the most positive is a maximum, is used in this data sheet.

Note 7: Typical values are for DESIGN AID ONLY, not guaranteed nor subject to production testing.

Note 8: I_{D(on)} is leakage from driver into "ON" switch.

The electrical characteristics above are a reproduction of a portion of Siliconix's copyrighted 1985 data book. This information does not constitute any representation by Maxim that Siliconix's products will perform in accordance with these specifications. The "Electrical Characteristics Table" along with descriptive excerpts from the original manufacturer's data sheet have been included in this data sheet solely for comparative purposes.



Quad SPST CMOS Analog Switches

- ◆ Significantly Reduced Power Consumption
- ◆ Lower Input Current Over Temperature
- ◆ No Input Current Spike

ABSOLUTE MAXIMUM RATINGS (MAX331, DG201A) This device conforms to the Absolute Maximum Ratings on the adjacent page.

ELECTRICAL CHARACTERISTICS (MAX331, DG201A): Specifications below satisfy or exceed all "tested" parameters on adjacent page.

(V⁺ = +15V, V⁻ = -15V, GND = 0V, T_A = +25°C, unless otherwise noted)

| | PARAMETER | SYMBOL | TEST CONDITIONS | LIMITS | | | | UNITS | |
|--------------------------------|---|---|---|--|-----------------|-----------------|-----------------|-------|----|
| | | | | MAX331/DG201AA | | DG201A,B,C | | | |
| | | | | MIN (Note 6) | TYP (Note 7) | MAX (Note 6) | TYP (Note 7) | | |
| SWITCH | Analog Signal Range | V _{ANALOG} | | -15 | 15 | -15 | 15 | V | |
| | Drain-Source ON Resistance (Note 9) | r _{DS(on)} | V _D = ±10V, V _{IN} = 0.8V, I _S = 1mA | | 115 | 175 | 115 | 200 | Ω |
| | Source OFF Leakage Current | I _{S(off)} | V _{IN} = 2.4V | V _S = 14V, V _D = -14V | 0.01 | 1.0 | 0.01 | 5.0 | nA |
| | | | V _S = -14V, V _D = 14V | -1.0 | -0.02 | -5.0 | -0.02 | | |
| | Drain OFF Leakage Current | I _{D(off)} | V _{IN} = 2.4V | V _S = 14V, V _D = -14V | 0.01 | 1.0 | 0.01 | 5.0 | |
| | | V _S = -14V, V _D = 14V | -1.0 | -0.02 | -5.0 | -0.02 | | | |
| | Drain ON Leakage Current (Note 8) | I _{D(on)} | V _S = -14V, V _{IN} = 0.8V | 0.1 | 1.0 | 0.1 | 5.0 | nA | |
| | | | V _D = 14V, V _{IN} = 0.8V | -1.0 | -0.15 | -5.0 | -0.15 | | |
| INPUT | Input Current With Input Voltage High | I _{INH} | V _{IN} = 2.4V | -1.0 | -0.0004 | -1.0 | -0.0004 | μA | |
| | | | V _{IN} = 15V | 0.003 | 1.0 | 0.003 | 1.0 | | |
| | Input Current With Input Voltage Low | I _{INL} | V _{IN} = 0V | -1.0 | -0.0004 | -1.0 | -0.0004 | μA | |
| DYNAMIC | Turn-ON Time | t _{on} | See Switching Time Test Circuit | 480 | 600 | 480 | 600 | ns | |
| | Turn-OFF Time | t _{off1} | | 370 | 450 | 370 | 450 | | |
| | Charge Injection | Q | C _L = 1000pF, V _{GEN} = 0V, R _{GEN} = 0Ω | 20 | | 20 | | pC | |
| | Source OFF Capacitance | C _{S(off)} | V _S = 0V, V _{IN} = 5V | 5 | | 5 | | pF | |
| | Drain OFF Capacitance | C _{D(off)} | f = 140kHz | 5 | | 5 | | | |
| | Channel ON Capacitance | C _{D(on)} + C _{S(on)} | | V _D = V _S = 0V, V _{IN} = 0V | 16 | | 16 | | |
| | OFF Isolation | | V _{IN} = 5V, Z _L = 75Ω | 70 | | 70 | | dB | |
| Crosstalk (Channel to Channel) | | V _S = 2.0V, f = 100kHz | 90 | | 90 | | | | |
| SUPPLY | Positive Supply Current | I ⁺ | All Channels ON or OFF | 0.02 | 0.1 | 0.02 | 0.1 | mA | |
| | Negative Supply Current | I ⁻ | All Channels ON or OFF | -0.1 | -0.01 | -0.1 | -0.01 | | |
| | Power Supply Range for Continuous Operation | V _{OP} | | ±4.5 | ±18 | ±4.5 | ±18 | V | |

Note 6: The algebraic convention whereby the most negative value is a minimum, and the most positive is a maximum, is used in this data sheet.

Note 7: Typical values are for DESIGN AID ONLY, not guaranteed nor subject to production testing.

Note 8: I_{D(on)} is leakage from driver into "ON" switch.

Note 9: Electrical characteristics, such as ON Resistance, will change when power supplies other than ±15V, are used.

MAX331/DG201A/DG211

MAX331/DG201A/DG211

Quad SPST CMOS Analog Switches

ELECTRICAL CHARACTERISTICS (DG201A)

(V⁺ = +15V, V⁻ = -15V, GND = 0V, T_A = Full Operating Temperature Range)

| | PARAMETER | SYMBOL | TEST CONDITIONS | LIMITS | | | | | | UNITS | |
|---|---------------------------------------|---------------------|---|---|-----|------|-----------|-----|------|-------|----|
| | | | | DG201AA | | | DG201AB,C | | | | |
| | | | | MIN | TYP | MAX | MIN | TYP | MAX | | |
| SWITCH | Analog Signal Range | V _{ANALOG} | | -15 | 15 | | -15 | 15 | | V | |
| | Drain-Source ON Resistance | r _{DS(on)} | V _D = ±10V, V _{IN} = 0.8V, I _S = 1mA | | | 250 | | | 250 | Ω | |
| | Source OFF Leakage Current | I _{S(off)} | V _{IN} = 2.4V | V _S = 14V, V _D = -14V | | | 100 | | | 100 | nA |
| | | | | V _S = -14V, V _D = 14V | | | -100 | | | -100 | |
| | Drain OFF Leakage Current | I _{D(off)} | V _{IN} = 2.4V | V _S = 14V, V _D = -14V | | | 100 | | | 100 | nA |
| V _S = -14V, V _D = 14V | | | | | | -100 | | | -100 | | |
| Drain ON Leakage Current (Note 10) | I _{D(on)} | | V _S = -14V, V _{IN} = 0.8V V _D = 14V, V _{IN} = 0.8V | | | 200 | | | 200 | nA | |
| INPUT | Input Current With Input Voltage High | I _{INH} | V _{IN} = 2.4V | | | -1.0 | | | -10 | μA | |
| | | | V _{IN} = 15V | | | | | | -10 | | |
| | Input Current With Input Voltage Low | I _{INL} | V _{IN} = 0V | | | -10 | | | -10 | μA | |

Note 10: I_{D(on)} is leakage from driver into "ON" switch.

The electrical characteristics above are a reproduction of a portion of Siliconix's copyrighted 1985 data book. This information does not constitute any representation by Maxim that Siliconix's products will perform in accordance with these specifications. The "Electrical Characteristics Table" along with descriptive excerpts from the original manufacturer's data sheet have been included in this data sheet solely for comparative purposes.

Switching Time Test Circuit

Switch output waveform shown for V_S = constant with logic input waveform as shown. Note that V_S may be +ve or -ve as per switching times test circuit.

V_O is the steady state output with switch on. Feed-through via gate capacitance may result in spikes at leading and trailing edge of output waveform.

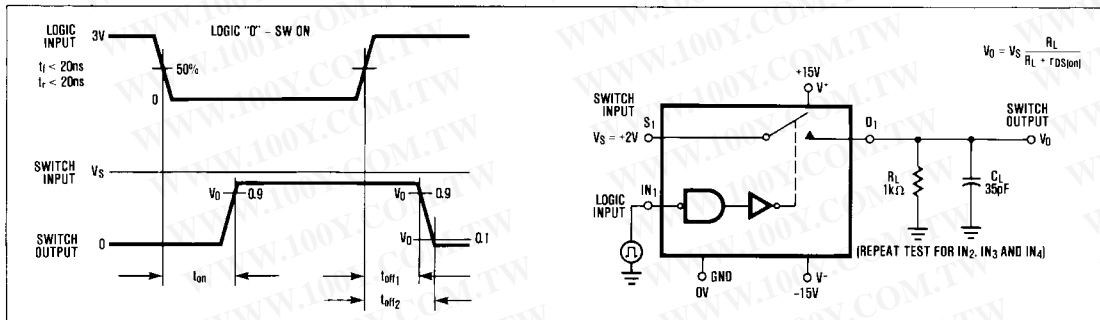

Typical R_{DS(ON)} vs. Power Supplies for Maxim's MAX331, DG201A and DG211

| POWER SUPPLIES | R _{DS(ON)} AT ANALOG SIGNAL LEVEL | | | | | |
|----------------|--|------|------|------|------|------|
| | -5V | +5V | -10V | +10V | -15V | +15V |
| ±5V | 350Ω | 380Ω | | | | |
| ±10V | | | 165Ω | 250Ω | | |
| ±15V | | | 125Ω | 160Ω | 135Ω | 155Ω |



Quad SPST CMOS Analog Switches

ELECTRICAL CHARACTERISTICS (MAX331, DG201A):

(V⁺ = +15V, V⁻ = -15V, GND = 0V, T_A = full operating temperature range)

| | PARAMETER | SYMBOL | TEST CONDITIONS | LIMITS | | | | | | UNITS |
|------------------------------------|---------------------------------------|------------------------|---|---|-----|-----|-----------|-----|-----|-------|
| | | | | MAX331/DG201AA | | | DG201AB,C | | | |
| | | | | MIN | TYP | MAX | MIN | TYP | MAX | |
| SWITCH | Analog Signal Range | V _{ANALOG} | | -15 | | 15 | -15 | | 15 | V |
| | Drain-Source ON Resistance (Note 11) | r _{DS(on)} | V _D = ±10V, V _{IN} = 0.8V, I _S = 1mA | | | 250 | | | 250 | Ω |
| | Source OFF Leakage Current | I _{S(off)} | V _{IN} = 2.4V | V _S = 14V, V _D = -14V | | | 100 | | | nA |
| | | | V _S = -14V, V _D = 14V | -100 | | | -100 | | | |
| | | | V _S = 14V, V _D = -14V | | | 100 | | | 100 | |
| Drain OFF Leakage Current | I _{D(off)} | V _{IN} = 2.4V | V _S = -14V, V _D = 14V | -100 | | | -100 | | | |
| Drain ON Leakage Current (Note 10) | I _{D(on)} | | V _S = -14V, V _{IN} = 0.8V | | | 200 | | | 200 | |
| | | | V _D = 14V, V _{IN} = 0.8V | -200 | | | -200 | | | |
| INPUT | Input Current With Input Voltage High | I _{INH} | V _{IN} = 2.4V | -1.0 | | | -1.0 | | | μA |
| | | | V _{IN} = 15V | | | 1.0 | | | 1.0 | |
| | Input Current With Input Voltage Low | I _{INL} | V _{IN} = 0V | -1.0 | | | -1.0 | | | |

Note 10: I_{D(on)} is leakage from driver into "ON" switch.

Note 11: Electrical characteristics, such as ON Resistance, will change when power supplies other than ±15V, are used.

Protecting Against Fault Conditions

Fault conditions occur when power supplies are turned off when input signals are still present or when over voltages occur at the inputs during normal operation. In either case, source-to-body diodes can be forward biased and conduct current from the signal source. If this current is required to be kept to low (μA) levels then the addition of external protection diodes is recommended.

To provide protection for over-voltages up to 20V above the supplies, a 1N4001 or 1N914 type diode should be placed in series with the positive and negative supplies as shown in Fig. 1. The addition of these diodes will reduce the analog signal range to 1 volt below the positive supply and 1 volt above the negative supply.

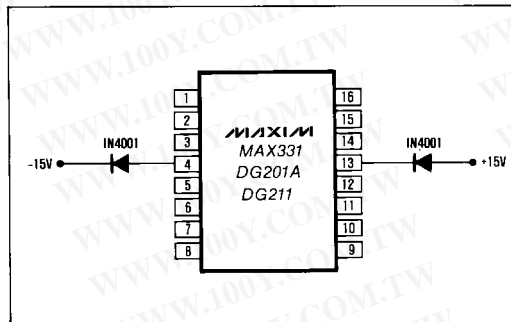
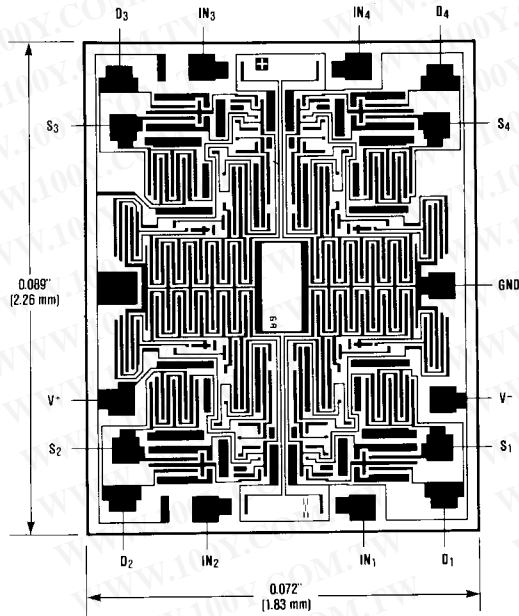

Figure 1. Protection Against Fault Conditions

Quad SPST CMOS Analog Switches

MAX331/DG201A/DG211

Chip Topography



Package Information

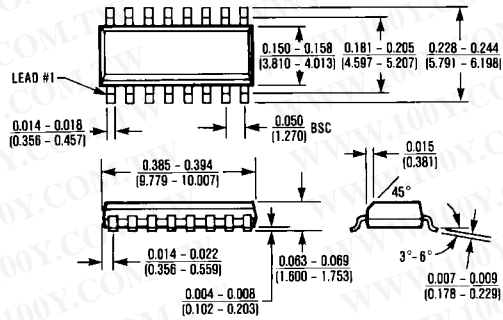

16 Lead Small Outline (SE)

$\theta_{JA} = 110^{\circ}\text{C/W}$
 $\theta_{JC} = 60^{\circ}\text{C/W}$

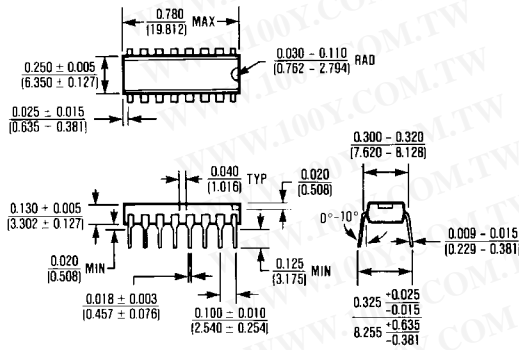

16 Lead Plastic DIP

$\theta_{JA} = 135^{\circ}\text{C/W}$
 $\theta_{JC} = 65^{\circ}\text{C/W}$

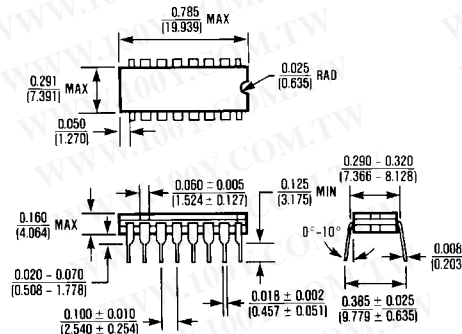

16 Lead Cerdip

$\theta_{JA} = 100^{\circ}\text{C/W}$
 $\theta_{JC} = 60^{\circ}\text{C/W}$