



August 1986
 Revised April 2000

DM74LS164

8-Bit Serial In/Parallel Out Shift Register

General Description

These 8-bit shift registers feature gated serial inputs and an asynchronous clear. A low logic level at either input inhibits entry of the new data, and resets the first flip-flop to the low level at the next clock pulse, thus providing complete control over incoming data. A high logic level on either input enables the other input, which will then determine the state of the first flip-flop. Data at the serial inputs may be changed while the clock is HIGH or LOW, but only information meeting the setup and hold time requirements will be entered. Clocking occurs on the LOW-to-HIGH level transition of the clock input. All inputs are diode-clamped to minimize transmission-line effects.

Features

- Gated (enable/disable) serial inputs
- Fully buffered clock and serial inputs
- Asynchronous clear
- Typical clock frequency 36 MHz
- Typical power dissipation 80 mW

Ordering Code:

Order Number	Package Number	Package Description
DM74LS164M	M14A	14-Lead Small Outline Integrated Circuit (SOIC), JEDEC MS-120, 0.150 Narrow
DM74LS164N	N14A	14-Lead Plastic Dual-In-Line Package (PDIP), JEDEC MS-001, 0.300 Wide

Devices also available in Tape and Reel. Specify by appending the suffix letter "X" to the ordering code.

Connection Diagram

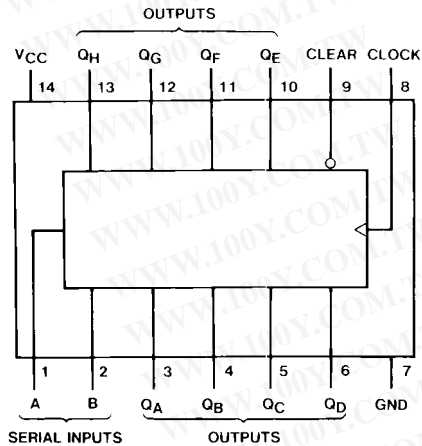

Function Table

Inputs				Outputs			
Clear	Clock	A	B	Q _A	Q _B	...	Q _H
L	X	X	X	L	L	...	L
H	L	X	X	Q _{A0}	Q _{B0}	...	Q _{H0}
H	↑	H	H	H	Q _{An}	...	Q _{Gn}
H	↑	L	X	L	Q _{An}	...	Q _{Gn}
H	↑	X	L	L	Q _{An}	...	Q _{Gn}

H = HIGH Level (steady state)

L = LOW Level (steady state)

X = Don't Care (any input, including transitions)

↑ = Transition from LOW-to-HIGH level

Q_{A0}, Q_{B0}, Q_{H0} = The level of Q_A, Q_B, or Q_H, respectively, before the indicated steady-state input conditions were established.

Q_{An}, Q_{Gn} = The level of Q_A or Q_G before the most recent ↑ transition of the clock; indicates a one-bit shift.

DM74LS164 8-Bit Serial In/Parallel Out Shift Register

DM74LS164

Logic Diagram

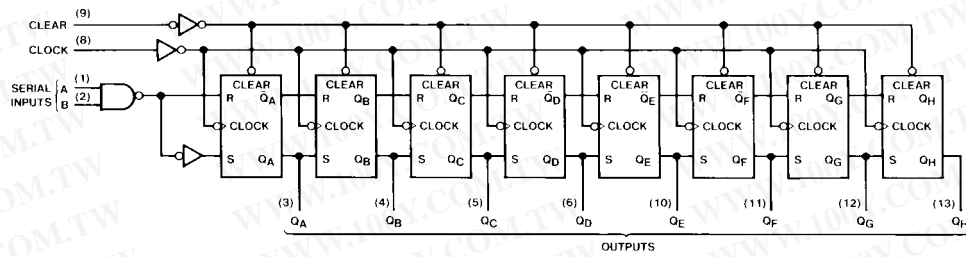

Timing Diagram

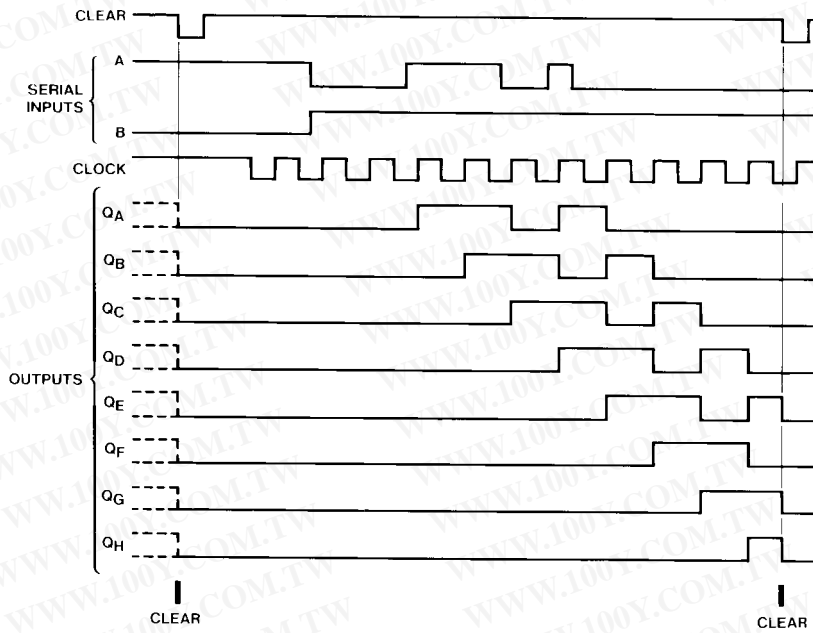

Absolute Maximum Ratings (Note 1)

Supply Voltage	7V
Input Voltage	7V
Operating Free Air Temperature Range	0°C to +70°C
Storage Temperature Range	-65°C to +150°C

Note 1: The "Absolute Maximum Ratings" are those values beyond which the safety of the device cannot be guaranteed. The device should not be operated at these limits. The parametric values defined in the Electrical Characteristics tables are not guaranteed at the absolute maximum ratings. The "Recommended Operating Conditions" tables will define the conditions for actual device operation.

Recommended Operating Conditions

Symbol	Parameter	Min	Nom	Max	Units
V _{CC}	Supply Voltage	4.75	5	5.25	V
V _{IH}	HIGH Level Input Voltage	2			V
V _{IL}	LOW Level Input Voltage			0.8	V
I _{OH}	HIGH Level Output Current			-0.4	mA
I _{OL}	LOW Level Output Current			8	mA
f _{CLK}	Clock Frequency (Note 2)	0		25	MHz
t _W	Pulse Width (Note 2)	Clock	20		ns
		Clear	20		
t _{SU}	Data Setup Time (Note 2)	17			ns
t _H	Data Hold Time (Note 2)	5			ns
t _{REL}	Clear Release Time (Note 2)	30			ns
T _A	Free Air Operating Temperature	0		70	°C

Note 2: T_A = 25°C and V_{CC} = 5V.

Electrical Characteristics

over recommended operating free air temperature range (unless otherwise noted)

Symbol	Parameter	Conditions	Min	Typ (Note 3)	Max	Units
V _I	Input Clamp Voltage	V _{CC} = Min, I _I = -18 mA			-1.5	V
V _{OH}	HIGH Level Output Voltage	V _{CC} = Min, I _{OH} = Max	2.7	3.4		V
		V _{IL} = Max, V _{IH} = Min				
V _{OL}	LOW Level Output Voltage	V _{CC} = Min, I _{OL} = Max		0.35	0.5	V
		V _{IL} = Max, V _{IH} = Min I _{OL} = 4 mA, V _{CC} = Min				
I _I	Input Current @ Max Input Voltage	V _{CC} = Max, V _I = 7V			0.1	mA
I _{IH}	HIGH Level Input Current	V _{CC} = Max, V _I = 2.7V			20	μA
I _{IL}	LOW Level Input Current	V _{CC} = Max, V _I = 0.4V			-0.4	mA
I _{OS}	Short Circuit Output Current	V _{CC} = Max (Note 4)	-20		-100	mA
I _{CC}	Supply Current	V _{CC} = Max (Note 5)		16	27	mA

Note 3: All typicals are at V_{CC} = 5V, T_A = 25°C.

Note 4: Not more than one output should be shorted at a time, and the duration should not exceed one second.

Note 5: I_{CC} is measured with all outputs OPEN, the SERIAL input grounded, the CLOCK input at 2.4V, and a momentary ground, then 4.5V, applied to the CLEAR input.

Switching Characteristics

at V_{CC} = 5V and T_A = 25°C

Symbol	Parameter	From (Input) To (Output)	R _L = 2 kΩ				Units
			C _L = 15 pF		C _L = 50 pF		
			Min	Max	Min	Max	
f _{MAX}	Maximum Clock Frequency		25				MHz
t _{PLH}	Propagation Delay Time LOW-to-HIGH Level Output	Clock to Output		27		30	ns
t _{PHL}	Propagation Delay Time HIGH-to-LOW Level Output	Clock to Output		32		40	ns
t _{PHL}	Propagation Delay Time HIGH-to-LOW Level Output	Clear to Output		36		45	ns

DM74LS164

Physical Dimensions inches (millimeters) unless otherwise noted

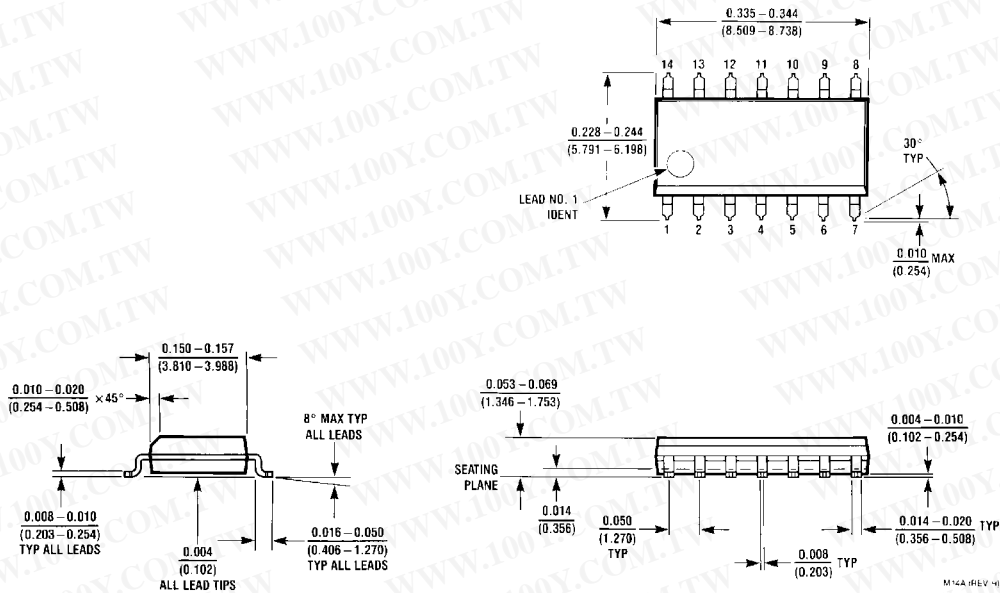

14-Lead Small Outline Integrated Circuit (SOIC), JEDEC MS-120, 0.150 Narrow Package Number M14A

Physical Dimensions inches (millimeters) unless otherwise noted (Continued)

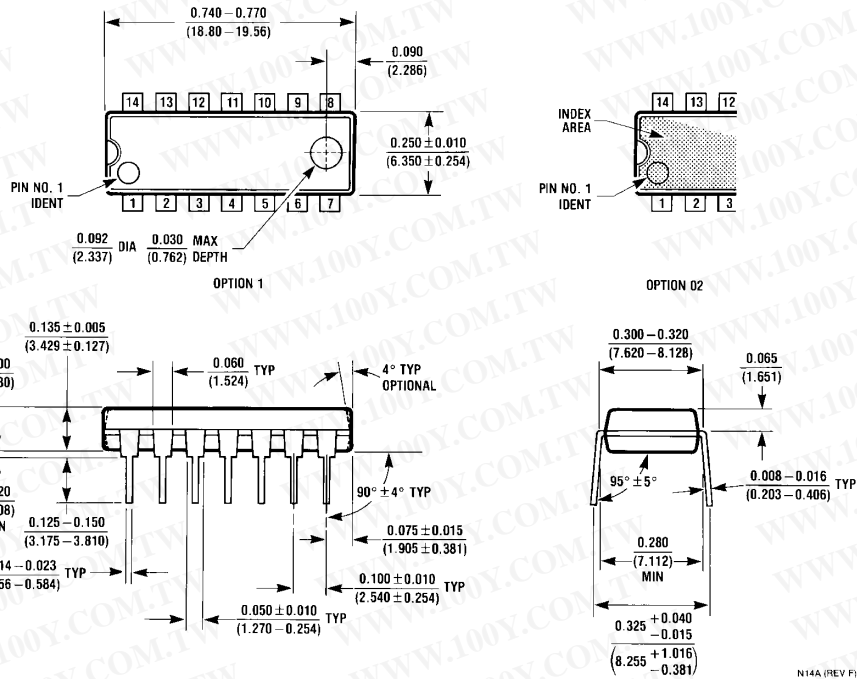

14-Lead Plastic Dual-In-Line Package (PDIP), JEDEC MS-001, 0.300 Wide Package Number N14A

DM74LS164 8-Bit Serial In/Parallel Out Shift Register

Fairchild does not assume any responsibility for use of any circuitry described, no circuit patent licenses are implied and Fairchild reserves the right at any time without notice to change said circuitry and specifications.

N14A (REV F)