

DP8310/DP8311

Octal Latched Peripheral Drivers

勝特力材料 886-3-5753170
 勝特力电子(上海) 86-21-54151736
 勝特力电子(深圳) 86-755-83298787
[Http://www.100y.com.tw](http://www.100y.com.tw)

General Description

The DP8310 and DP8311 Octal Latched Peripheral Drivers provide the function of latching eight bits of data with open collector outputs, each driving up to 100 mA DC with an operating voltage range of 30V. Both devices are designed for low input currents, high input/output voltages, and feature a power up clear (outputs off) function.

The DP8310 is positive edge latching. Two active low write/enable inputs are available for convenient data bussing without external gating.

The DP8311 is positive edge latching. The active low strobe input latches data or allows fall through operation when held at logic "0". The latches are cleared (outputs off) with a logic "0" on the clear pin.

Features

- High current, high voltage open collector outputs
- Low current, high voltage inputs

- All outputs simultaneously sink rated current "DC" with no thermal derating at maximum rated temperature
- Parallel latching or buffering
- Separate active low enables for easy data bussing
- Internal "glitch free" power up clear
- 10% V_{CC} tolerance

Applications

- High current high voltage drivers
- Relay drivers
- Lamp drivers
- LED drivers
- TRIAC drivers
- Solenoid drivers
- Stepper motor drivers
- Level translators
- Fiber-optic LED drivers

Connection Diagrams

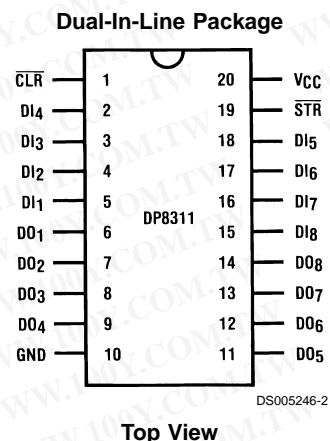
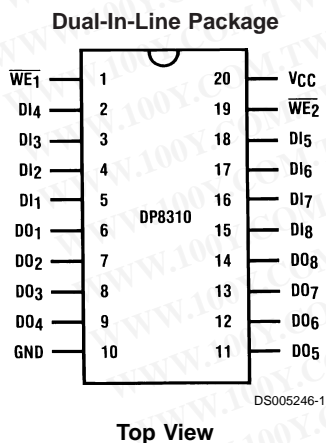

Order Number DP8310N or DP8311N
See NS Package Number N20A

Absolute Maximum Ratings (Note 1)

If Military/Aerospace specified devices are required, please contact the National Semiconductor Sales Office/Distributors for availability and specifications.

Supply Voltage	7.0V
Input Voltage	35V
Output Voltage	35V
Maximum Power Dissipation* at $T_A = 25^\circ\text{C}$	
DP8310/DP8311	2005 mW
Storage Temperature Range	-65°C to $+150^\circ\text{C}$
Lead Temperature (Soldering, 4 sec.)	260°C

DC Electrical Characteristics

DP8310 and DP8311 (Notes 2, 3)

Symbol	Parameter	Conditions	Min	Typ	Max	Units
V_{IH}	Logical "1" Input Voltage		2.0			V
V_{IL}	Logical "0" Input Voltage				0.8	V
V_{OL}	Logical "0" Output Voltage	Data outputs latched to logical "0", $V_{CC} = \text{Min}$. $I_{OL} = 100 \text{ mA}$		0.35	0.5	V
I_{OH}	Logical "1" Output Current	Data outputs latched to logical "1", $V_{CC} = \text{Min}$. $V_{OH} = 30\text{V}$		2.5	250	μA
I_{IH}	Logical "1" Input Current	$V_{IH} = 2.7\text{V}$, $V_{CC} = \text{Max}$		0.1	25	μA
I_i	Input Current at Maximum Input Voltage	$V_{IN} = 30\text{V}$, $V_{CC} = \text{Max}$		1	250	μA
I_{iL}	Logical "0" Input Current	$V_{IN} = 0.4\text{V}$, $V_{CC} = \text{Max}$		-215	-300	μA
V_{clamp}	Input Clamp Voltage	$I_{IN} = 12 \text{ mA}$		-0.8	-1.5	V
I_{CC0}	Supply Current, Outputs On	Data outputs latched to a logical "0". All Inputs are at logical "1", $V_{CC} = \text{Max}$.		100 88	152 125	mA mA
I_{CC1}	Supply Current, Outputs Off	Data outputs latched to a logic "1". Other conditions same as I_{CC0} .		40 25	57 36	mA mA

AC Electrical CharacteristicsDP8310 only: $V_{CC} = 4.5\text{V}$, $T_A = 25^\circ\text{C}$

Symbol	Parameter	Conditions	Min	Typ	Max	Units
t_{pd0}	High to Low Propagation Delay Write Enable Input to Output	(Figure 1)		40	120	ns
t_{pd1}	Low to High Propagation Delay Write Enable Input to Output	(Figure 1)		70	150	ns
t_{SETUP}	Minimum Set-Up Time Data in to Write Enable Input	$t_{HOLD} = 0 \text{ ns}$ (Figure 1)	45	20		ns
t_{pWH} , t_{pWL}	Minimum Write Enable Pulse Width	(Figure 1)	60	25		ns
t_{THL}	High to Low Output Transition Time	(Figure 1)		16	35	ns
t_{TLH}	Low to High Output Transition Time	(Figure 1)		38	70	ns
C_{IN}	"N" Package (Note 4)			5	15	pF

Note: *Derate N20A package 15.4 mW/°C above $T_A = 25^\circ\text{C}$, $\theta_{JA} = 65^\circ\text{C/W}$.**Operating Conditions**

	Min	Max	Units
Supply Voltage (V_{CC})	4.5	5.5	V
Temperature			
DP8310/DP8311	0	+70	$^\circ\text{C}$
Input Voltage		30	V
Output Voltage		30	V

勝特力材料 886-3-5753170
 勝特力电子(上海) 86-21-54151736
 勝特力电子(深圳) 86-755-83298787
[Http://www.100y.com.tw](http://www.100y.com.tw)

AC Electrical Characteristics

DP8311 only: $V_{CC} = 5V$, $T_A = 25^\circ C$

Symbol	Parameter	Conditions	Min	Typ	Max	Units
t_{pd0}	High to Low Propagation Delay Data In to Output	(Figure 2)		30	60	ns
t_{pd1}	Low to High Propagation Delay Data to Output	(Figure 2)		70	100	ns
t_{SETUP}	Minimum Set-Up Time Data in to Strobe Input	$t_{HOLD} = 0$ ns (Figure 2)	0	-25		ns
t_{pWL}	Minimum Strobe Enable Pulse Width	(Figure 2)	60	35		ns
t_{pdC}	Propagation Delay Clear to Data Output	(Figure 2)		70	135	ns
t_{pWC}	Minimum Clear Input Pulse Width	(Figure 2)	60	25		ns
t_{THL}	High to Low Output Transition Time	(Figure 2)		20	35	ns
t_{TLH}	Low to High Output Transition Time	(Figure 2)		38	60	ns
C_{IN}	Input Capacitance — Any Input	(Note 4)		5	15	pF

Note 1: "Absolute Maximum Ratings" are those values beyond which the safety of the device cannot be guaranteed. Except for "Operating Temperature Range" they are not meant to imply that the devices should be operated at these limits. The table of "Electrical Characteristics" provides conditions for actual device operation.

Note 2: Unless otherwise specified min/max limits apply across the $0^\circ C$ to $+70^\circ C$ for the DP8310/DP8311. All typical values are for $T_A = 25^\circ C$, $V_{CC} = 5V$.

Note 3: All currents into device pins shown as positive, out of device pins as negative, all voltages referenced to ground unless otherwise noted.

Note 4: Input capacitance is guaranteed by periodic testing. $f_{TEST} = 10$ kHz at 300 mV, $T_A = 25^\circ C$.

勝特力材料 886-3-5753170
 勝特力电子(上海) 86-21-54151736
 勝特力电子(深圳) 86-755-83298787
[Http://www.100y.com.tw](http://www.100y.com.tw)

Logic Table

DP8310			
Write Enable 1 WE ₁	Write Enable 2 WE ₂	Data Input DI ₁₋₈	Data Output DO ₁₋₈
0	0	X	Q
0	↗	0	1
0	↗	1	0
↗	0	0	1
↗	0	1	0
0	1	X	Q
1	0	X	Q
1	1	X	Q

DP8311			
Clear CLR	Strobe STR	Data Input DI ₁₋₈	Data Output DO ₁₋₈
1	1	X	Q
1	0	0	1
1	0	1	0
0	X	X	1

X = Don't Care
 1 = Outputs Off
 0 = Outputs On
 Q = Pre-existing Output
 ↗ = Positive Edge Transition

Block Diagrams

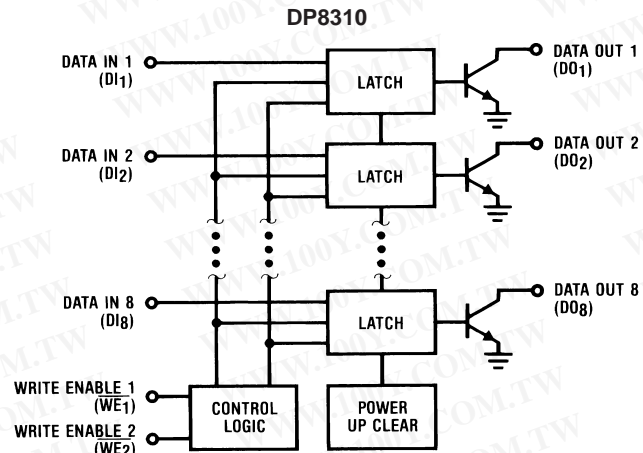

DS005246-3

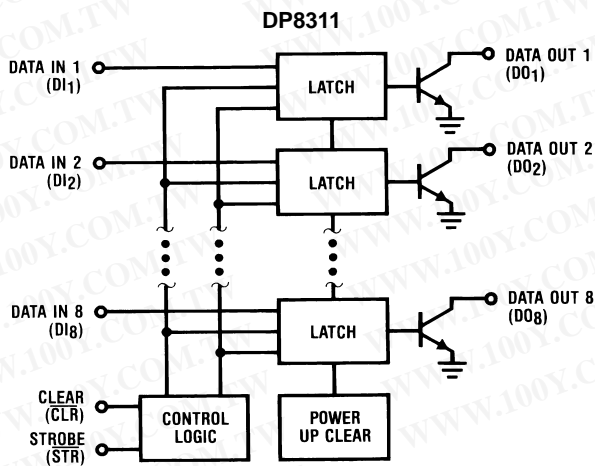

DS005246-4

勝特力材料 886-3-5753170
 勝特力电子(上海) 86-21-54151736
 勝特力电子(深圳) 86-755-83298787
[Http://www.100y.com.tw](http://www.100y.com.tw)

Switching Time Waveforms

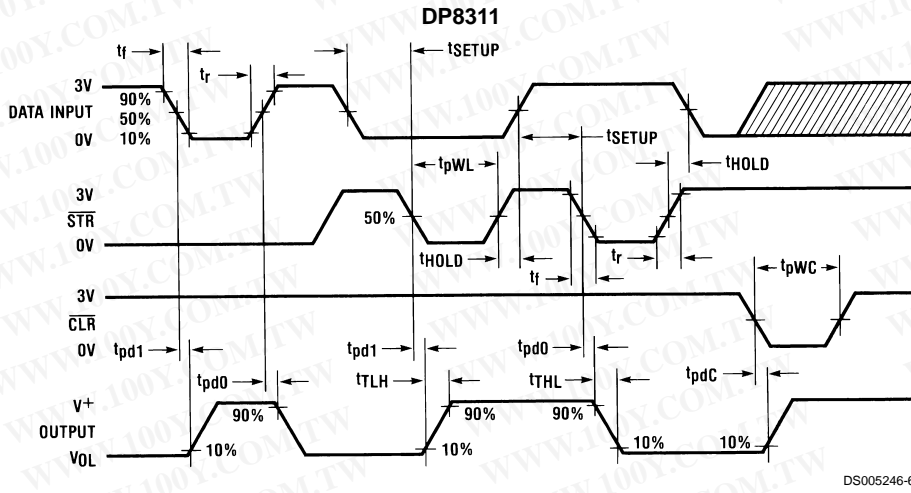
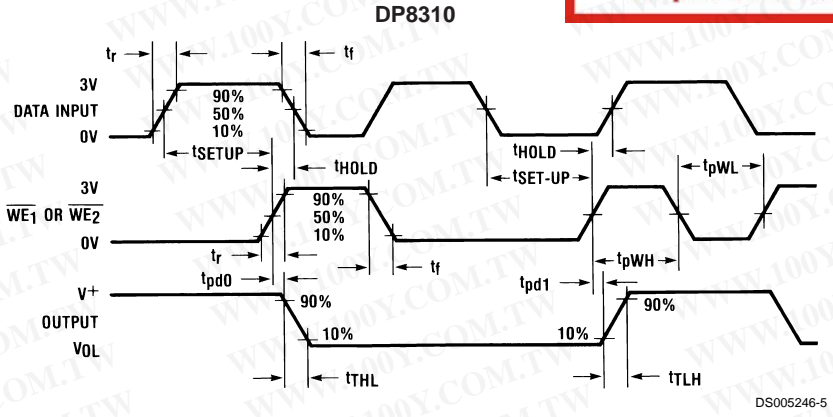

Switching Time Test Circuits

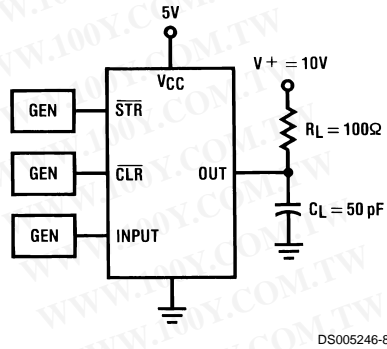
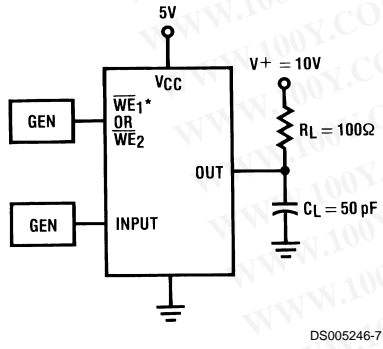

* $\overline{WE}_1 = 0\text{V}$ When the Input = \overline{WE}_2

FIGURE 1. DP8310

Pulse Generator Characteristics:
 $Z_O = 50\Omega$, $t_r = t_f = 5\text{ ns}$

FIGURE 2. DP8311

Typical Applications DP8310/11 Buffering High Current Device (Notes 5, 6)

PNP High Current Driver

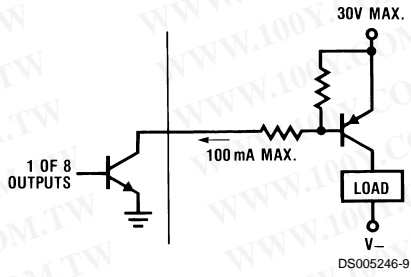

NPN High Current Driver

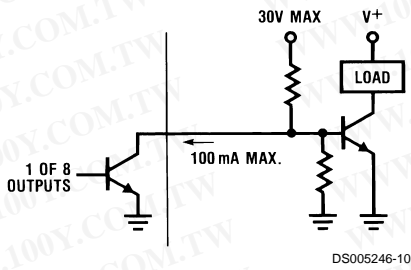

VMOS High Current Driver

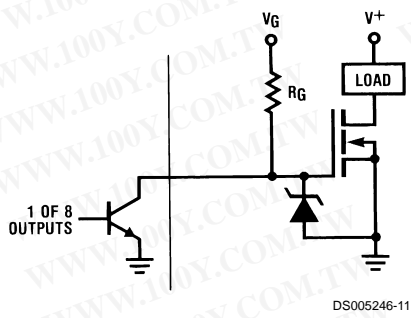

Circuit Used to Reduce Peak Transient Lamp Current

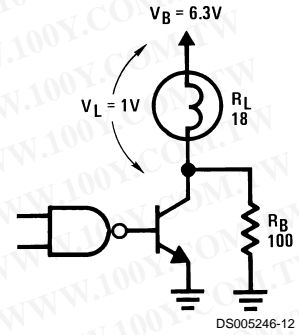

$$R_B = \left(\frac{V_B - V_L}{V_L} \right) R_L$$

$$R_B = \left(\frac{6.3 - 1}{1} \right) 18 \Omega = 95.4 \approx 100 \Omega$$

勝特力材料 886-3-5753170
 勝特力电子(上海) 86-21-54151736
 勝特力电子(深圳) 86-755-83298787
[Http://www.100y.com.tw](http://www.100y.com.tw)

Typical Applications DP8310/11 Buffering High Current Device (Notes 5, 6) (Continued)

Eight Output/Four Output Fiber Optic LED Driver

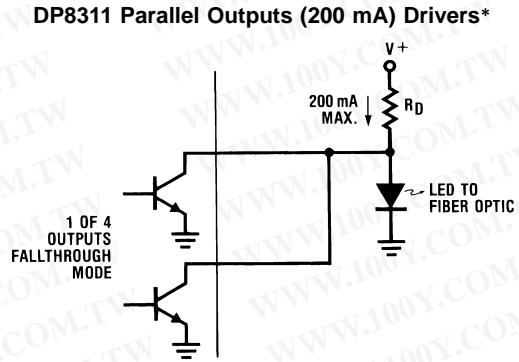
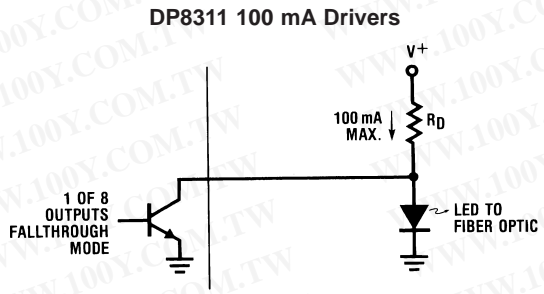

*Parallel only adjacent outputs

8-Bit Level Translator Driver

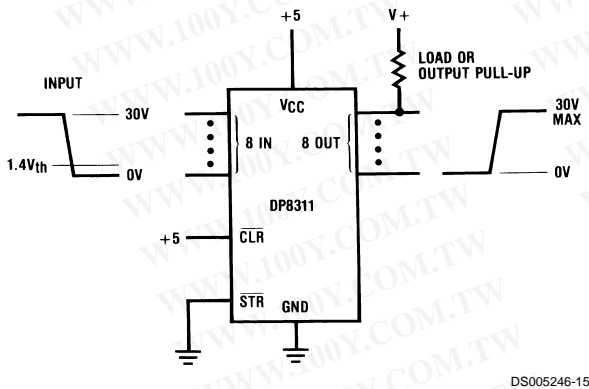

Digital Controlled 256 Level Power Supply from 1.2V to 30V

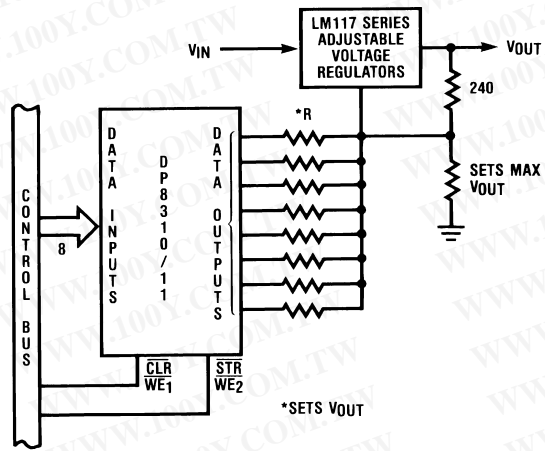

勝特力材料 886-3-5753170
 勝特力电子(上海) 86-21-54151736
 勝特力电子(深圳) 86-755-83298787
[Http://www.100y.com.tw](http://www.100y.com.tw)

Typical Applications DP8310/11 Buffering High Current Device (Notes 5, 6) (Continued)

200 mA Drive for a 4 Phase Bifilar Stepper Motor

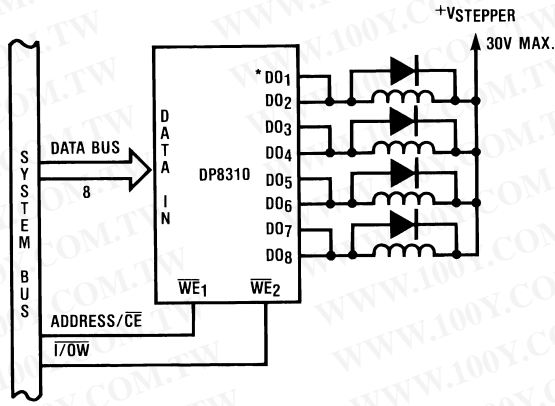

DS005246-17

*Parallel only adjacent outputs

Reading the State of the Latched Peripherals

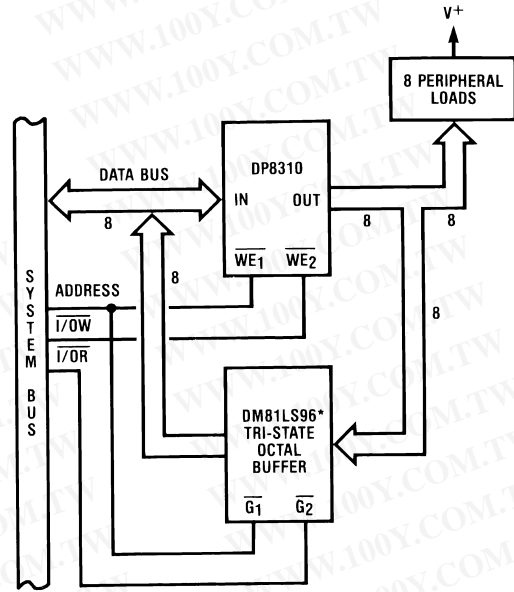

DS005246-18

*High Level Input
Voltage must not
Exceed V_{CC} of the
DM81LS96

Note 5: Always use good V_{CC} bypass and ground techniques to suppress transients caused by peripheral loads.

Note 6: Printed circuit board mounting is required if these devices are operated at maximum rated temperature and current (all outputs on DC).

勝特力材料 886-3-5753170
 勝特力电子(上海) 86-21-54151736
 勝特力电子(深圳) 86-755-83298787
[Http://www.100y.com.tw](http://www.100y.com.tw)

Physical Dimensions inches (millimeters) unless otherwise noted

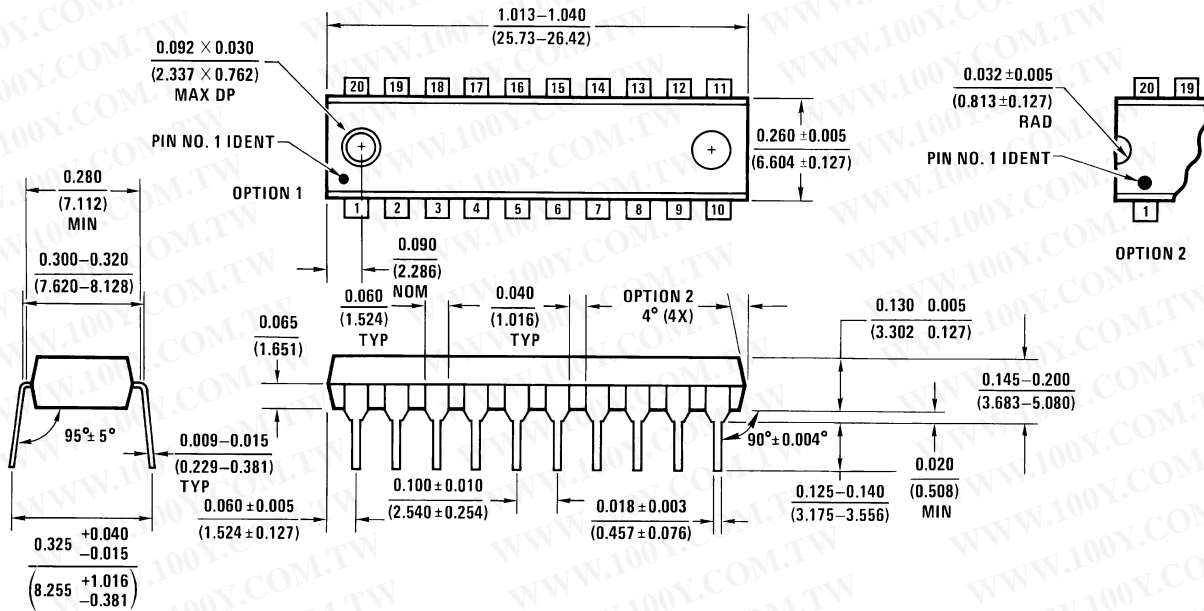

N20A (REV G)

Molded Dual-In-Line Package (N)
Order Number DP8310N or DP8311N
NS Package Number N20A

勝特力材料 886-3-5753170
 勝特力电子(上海) 86-21-54151736
 勝特力电子(深圳) 86-755-83298787
[Http://www.100y.com.tw](http://www.100y.com.tw)

LIFE SUPPORT POLICY

NATIONAL'S PRODUCTS ARE NOT AUTHORIZED FOR USE AS CRITICAL COMPONENTS IN LIFE SUPPORT DEVICES OR SYSTEMS WITHOUT THE EXPRESS WRITTEN APPROVAL OF THE PRESIDENT AND GENERAL COUNSEL OF NATIONAL SEMICONDUCTOR CORPORATION. As used herein:

1. Life support devices or systems are devices or systems which, (a) are intended for surgical implant into the body, or (b) support or sustain life, and whose failure to perform when properly used in accordance with instructions for use provided in the labeling, can be reasonably expected to result in a significant injury to the user.
2. A critical component is any component of a life support device or system whose failure to perform can be reasonably expected to cause the failure of the life support device or system, or to affect its safety or effectiveness.

