

勝特力材料 886-3-5753170  
 勝特力电子(上海) 86-21-54151736  
 勝特力电子(深圳) 86-755-83298787  
[Http://www.100y.com.tw](http://www.100y.com.tw)

**INTRODUCTION**

This easy-to-use kit provides a platform for the evaluation of PWM amplifiers using the SA16 pin-out configuration. It can be used to analyze a multitude of standard or proprietary circuit configurations, and is flexible enough to do most standard amplifier test configurations. The board is designed for surface mounting all components except the switching amplifier.

The schematic is shown in Figure 2. Note that all of the components shown on the schematic will probably not be used for any single circuit. Some components will simply be omitted, while others require installation of a jumper to complete the signal path.

Only components unique to the EK08 are provided in this kit. Hardware similar to that shown in figure 1 must be obtained locally.

**PARTS LIST**

Part #	Description	Quantity
HS18	Heatsink	1
MS02	PC mount Cage Jacks	2 Bag/8 each
EVAL10	PC Board	1
60SPG00001	Spacer Grommets	4
TW05	Thermal Washer	1 Box/10 each
ZX7R105KTL	1 $\mu$ F ST2225B105K501LLXW, Novacap	1
OX7R105KWN	1 $\mu$ F Cap 1825B105K201N, Novacap	1

**ASSEMBLY**

(See Figure 1)

1. From the non-silk screen side, insert and solder cage jacks. Be sure each one is fully seated.
2. From the non-silk screen side, push spacer grommets into PC board until fully seated. Grommets will snug when screws are inserted for heatsink mounting.
3. Apply TW05 thermal washer to the bottom of the SA16.
4. Use #14 sleeving to insulate and align at least 2 opposite pins of the amplifier.
5. Mount amplifier to heatsink using #6 screws and nuts. Torque the part to the specified 8 to 10 in-lbs (.9 to 1.13 N\*M). Do not over torque.
6. Install components as needed. External connections may be soldered directly or standard banana jacks may be soldered to these pads.
7. Insert amplifier pins into cage jacks and fasten board to heatsink.

**BEFORE YOU GET STARTED**

- \* All Apex amplifiers should be handled using proper ESD precautions.
- \* Always use the heatsink included in this kit with TW05 washer.
- \* Always use adequate power supply bypassing.
- \* Do not change connections while the circuit is powered.
- \* Initially set all power supplies to the minimum operating levels allowed in the device data sheet.
- \* Check for oscillations.

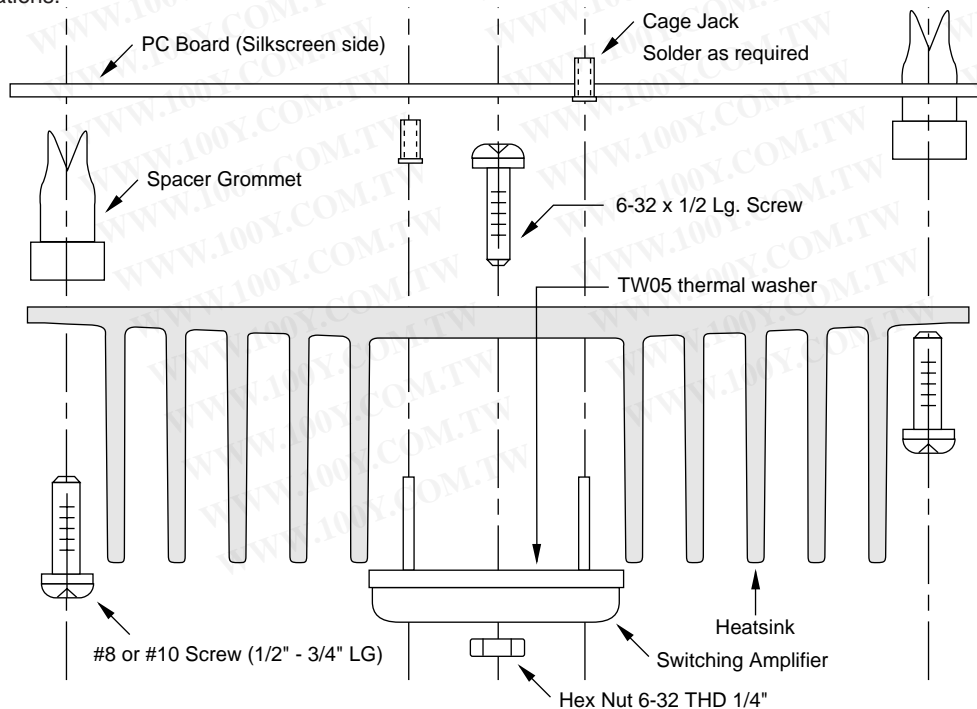
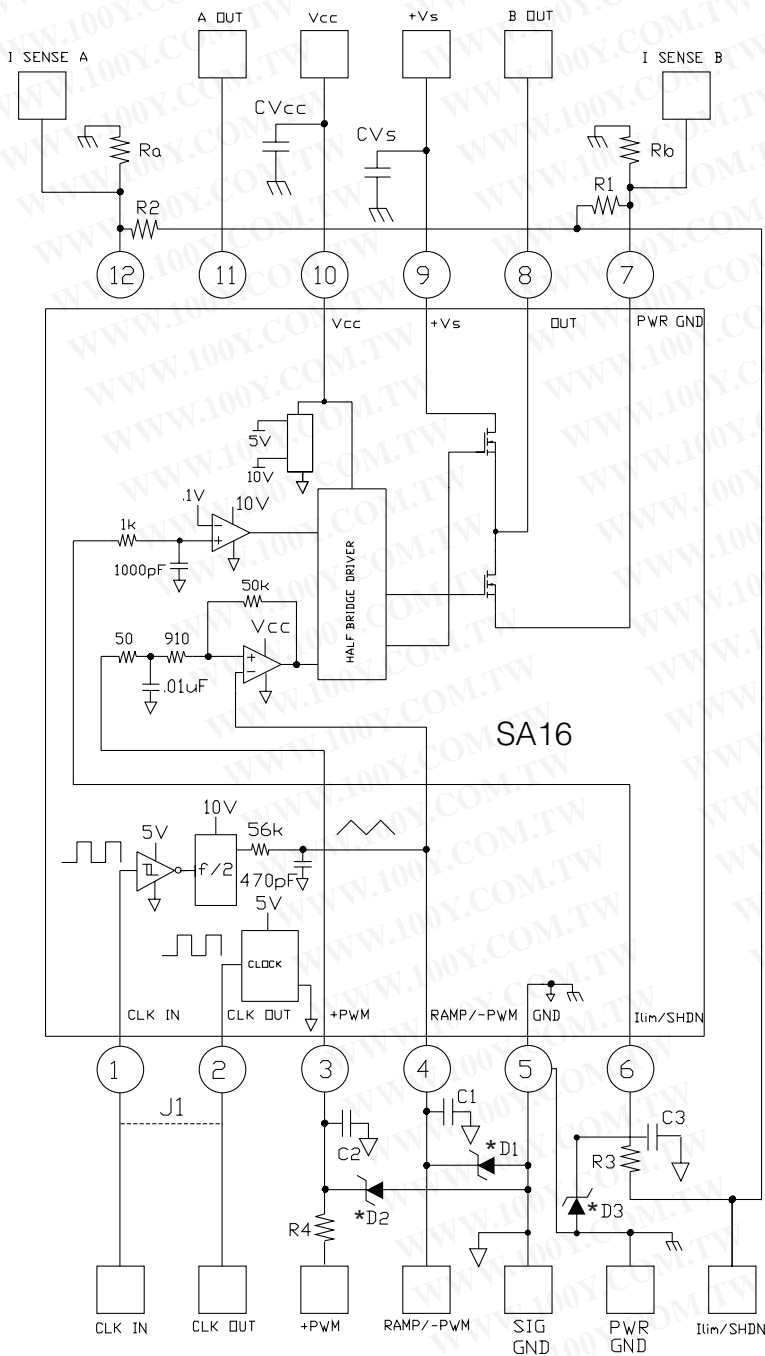

FIGURE 1.

FIGURE 2. PCB SCHEMATIC.



\* Input protection, 10V zener diode.

A block diagram of the SA16 is shown in Figure 2 along with pcb connections of all the commonly used external components. Your application circuit will not use all of the components. You may have to jumper some components to make the desired electrical connections. J1 is an optional way to connect the clock circuit. Power supply bypassing is particularly important and that is why high quality ceramic chip capacitors are supplied with the kit. In addition you may need to add a 10-50 uF or larger capacitor on the +Vs pin. This additional capacitor needs to be rated for switching operation. Note that the signal ground and power ground are separated and tie together only at the ground pin (5). A breadboarding area is supplied which can accommodate 1 or 2 IC amplifiers and associated components. The large terminal pads can be used to solder wire connections or banana jacks.

Note that the EK08 Evaluation Kit uses the same circuit board as the EK05 Evaluation kit intended for Apex's model SA06. The SA16 is a half bridge version of the SA06 and is identical in design except for that fact. Some of the pin designations of the SA16 are, however, different. The SA16's OUT (PIN 8) is equivalent to the SA06's B OUT (PIN 8). The SA16's PWR GND (PIN 7) is equivalent to the SA06's I SENSE B (PIN 7). Pins 11 and 12 of the SA16 are not connected. The designations on the PCB are those used for the SA06. See the SA16 data sheet for specific operating considerations.

FIGURE 3. FUNCTIONAL TEST CIRCUIT

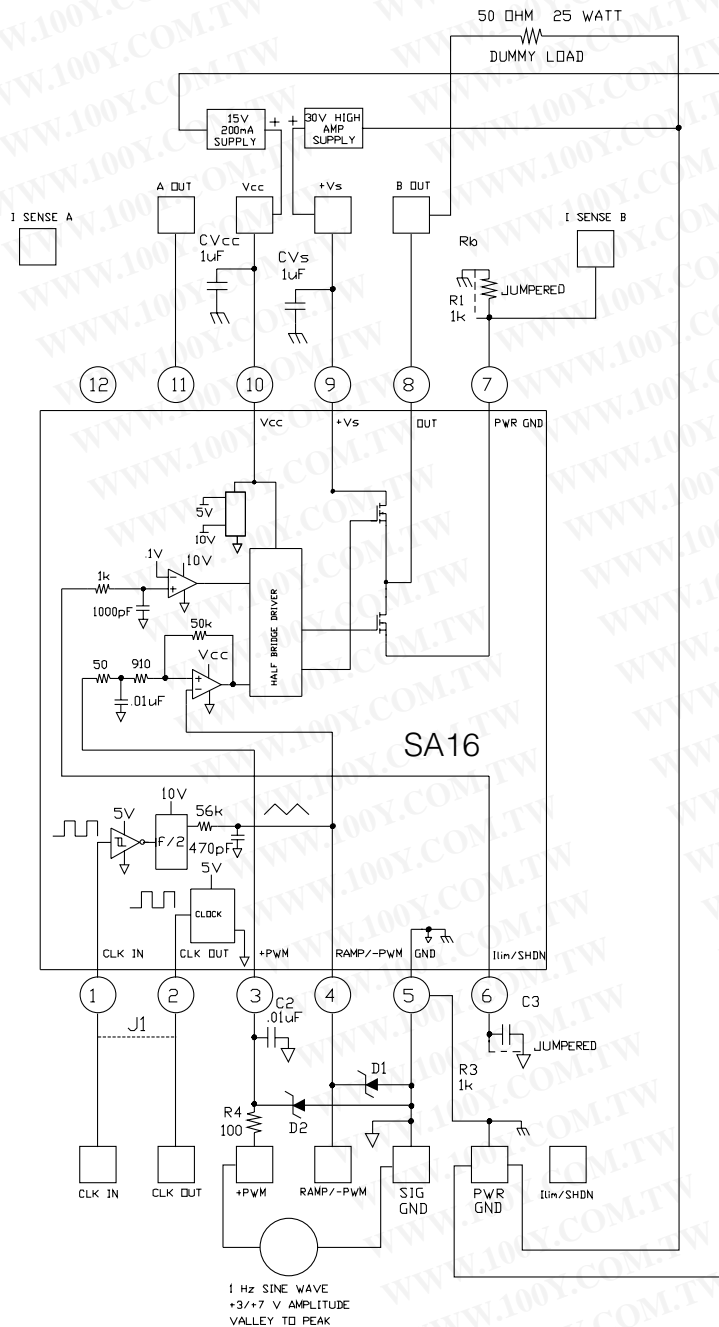

The schematic of Figure 3 can be used to verify the functionality of your amplifier and help you gain a familiarity with proper operation. At Out, with respect to ground, you should observe a square wave approximately 30 V in amplitude with a fixed frequency and duty cycle that varies from approximately 0 to 100% at a rate of 1 Hz.

FIGURE 4. PCB COMPONENT SIDE

