

INTRODUCTION

This easy-to-use kit provides a platform for the evaluation of linear power amplifiers circuits using the PA94/PA95 pin-out. With ample breadboarding areas it is flexible enough to analyze a multitude of standard or proprietary circuit configurations. Critical connections for power supply bypassing, compensation and current limiting are pre-wired. Components not usually readily available in engineering labs are provided. External connection to the evaluation kit can be made via the terminals at the edge of the circuit board. These terminal pads are suitable for standard banana jacks or direct soldering of wires. The schematic is shown in Figure 1.

PARTS LIST

Part #	Description, Vendor	Quantity
HS27	Heatsink, Apex	1
EVAL23	PC Board, Apex	1
TW13	Thermal Washer, Apex	1 box, 10 ea.
P6KE440A	TransZorb, General Semiconductor (440V)	2
CDC01	Capacitor .01 μ F 1KV, Sprague 5GAS10	2

ASSEMBLY

- See Figure 2. Insert and solder the TransZorb diodes at D3 and D4 (440V).
- Insert and solder the disc bypass capacitors at C1 and C2.
- Insert the HS27 heatsink and solder the solderable studs from the opposite side of the PCB.
- Add banana jacks as necessary to complete connections to external circuits and power supplies.
- Insert the amplifier into the PCB mounting holes located in the space between the heatsink fins. So not solder the pins at this time.
- Hang the TW13 thermal washer near the end of a 6-32 X 3/8" screw. Slightly pull the amplifier away from the heat sink face. Use the screw to position the thermal washer behind the amplifier and insert the screw into the mounting hole of the heatsink. Use a 6-32 nut to secure the screw from the opposite side of the heatsink. It is important that the entire back surface of the amplifiers mounting tab be in contact with the heatsink. Adjust the amplifiers position and tighten the mounting screw as necessary for this to be so.
- Solder the amplifiers pins to the PCB.
- Add other passive components as necessary to complete your circuit.
- Most common configurations will ground the non-inverting pin of the amplifier. J1 is a convenient way to do this if necessary for your application circuit.
- The four holes at the corners of the circuit board are for mounting #6 standoff spacers if desired.
- R1-R5 are multiple feedback resistors in series. Commonly available resistors do not have a breakdown voltage sufficient to stand off the output voltage of the amplifier. Using multiple resistors will divide down the voltage that each resistor must withstand.

FIGURE 1.

Figure 2 shows the schematic of the evaluation kit's pre-wired connections. Components supplied with the kit are marked with an asterisk (*). See the amplifiers data sheet for full application information.

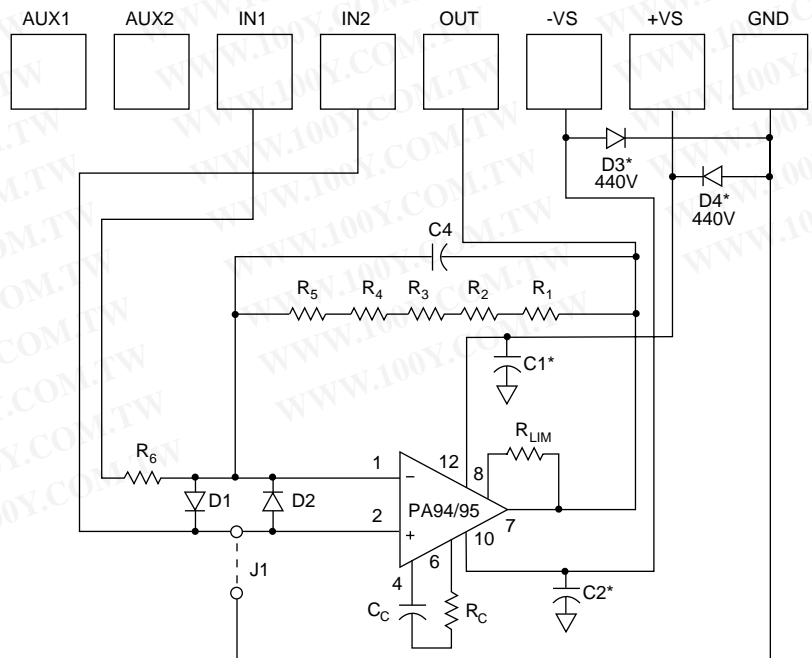

勝特力材料 886-3-5753170
 勝特力电子(上海) 86-21-54151736
 勝特力电子(深圳) 86-755-83298787
[Http://www.100y.com.tw](http://www.100y.com.tw)

EK19

勝特力材料 886-3-5753170
胜特力电子(上海) 86-21-54151736
胜特力电子(深圳) 86-755-83298787
[Http://www.100y.com.tw](http://www.100y.com.tw)

EVALUATION KIT
FOR PA94/PA95 PIN-OUT

FIGURE 2.

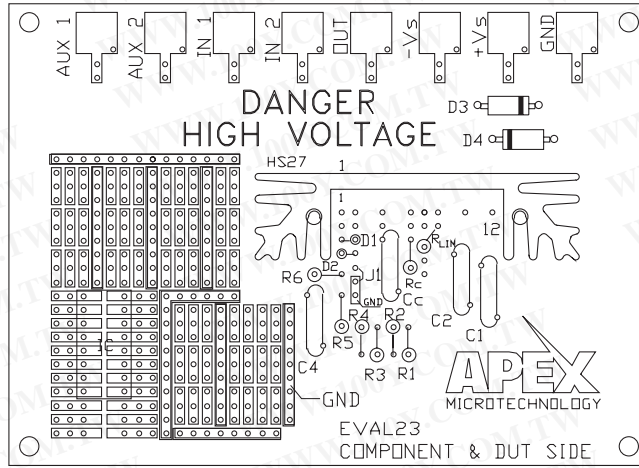

4.65 X 3.37

TOP VIEW

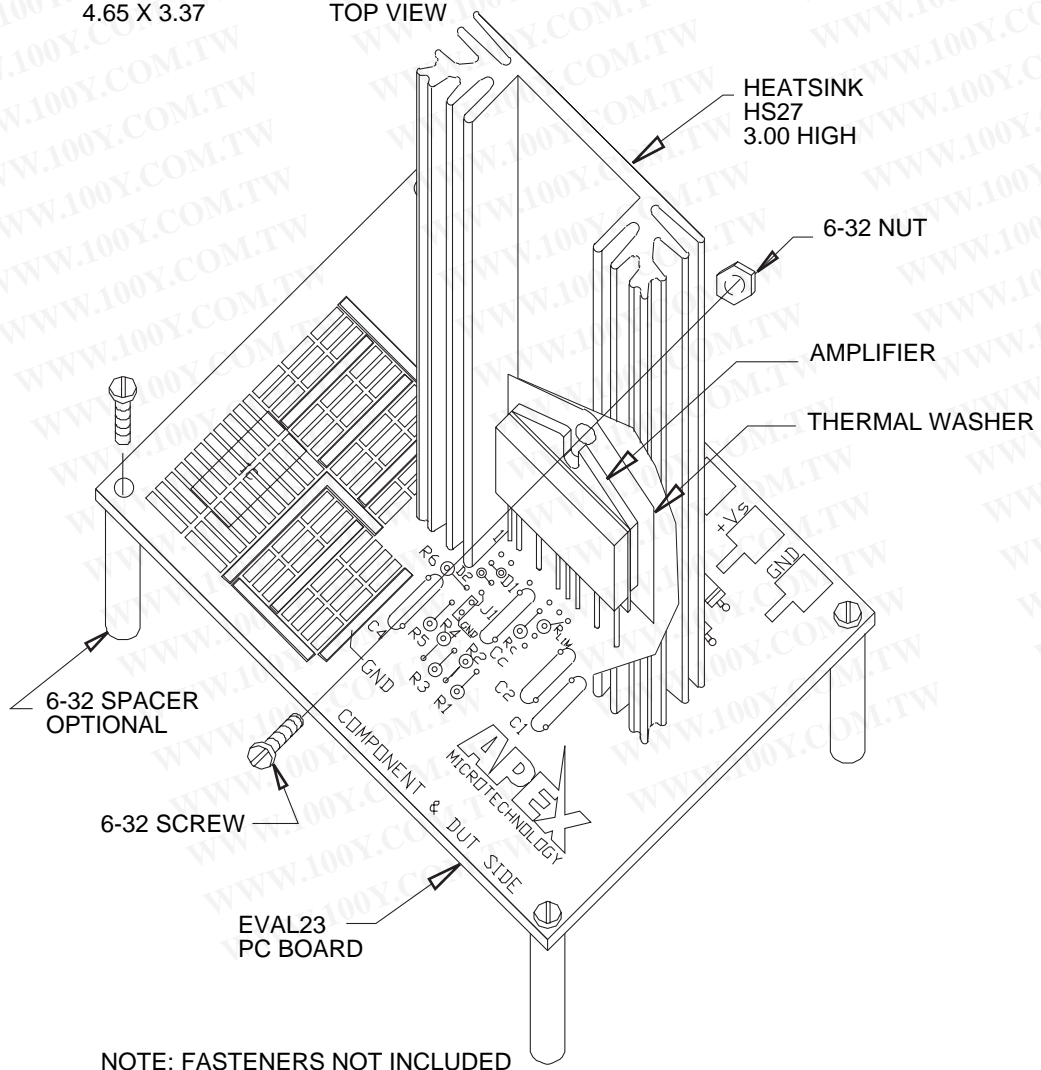

NOTE: FASTENERS NOT INCLUDED