

勝特力材料 886-3-5753170
 勝特力电子(上海) 86-21-54151736
 勝特力电子(深圳) 86-755-83298787
[Http://www.100y.com.tw](http://www.100y.com.tw)

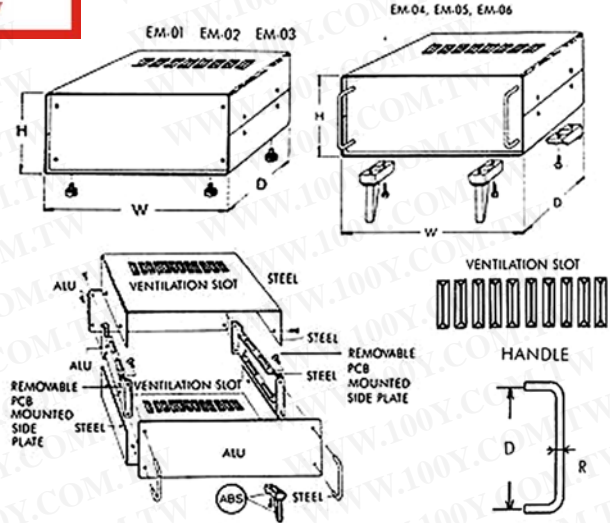

- WITH 1.0MM THICKNESS SHEET STEEL
- STEEL IS WITH GREY COLOR PAINTING.
- EM-01,EM-02,EM-03 IS WITH RUBBER FEET.
- EM-04, EM-05, EM-06 IS WITH SPECIAL TILT-FEET.
- TWO REMOVABLE PCB MOUNTED SIDE PLATE ARE SUPPLIED. THEY ARE MOUNTED INTERNALLY ON-TO PCM'S AND OUTSIDE CHASIS CAN BE AFIXED.
- SPECIAL ATTRACTIFVE VENTILATION SLOT ARE ON TOP AND BOTTOM CASE.
- EM-04, EM-05, EM-06 ARE SUPPLIED WITH STEEL HANDLE (NICKEL-PLATED) WITH LENGTH 94.5MM, 8Ø.
- EXTENDED PCB SIDE PLATED WITH SPECIAL GROOVE BLOCK SGB-02 PATENT IS PENDING WHICH IS IDEALLY FOR HOLDING PCB MOUNTING VERTICALLY AND Z DIRECTION WILL BE AVAILABLE SOON.

TYPE	W (M/M)	D (M/M)	H (M/M)	HANDLE	M/M ALUMINIUM THICKNESS OF FRONT PANEL	VENTILATION SLOT
EM-01	160	120	75	WITHOUT	1.5	12
EM-02	210	150	85	WITHOUT	1.5	18
EM-03	260	170	110	WITHOUT	1.5	18
EM-04	300	200	130	WITH	2	30
EM-05	360	230	140	WITH	2	30
EM-06	400	260	150	WITH	3	30