

ショットキーバリアダイオード

SCHOTTKY BARRIER DIODE

勝特力材料 886-3-5753170
 勝特力電子(上海) 86-21-54151736
 勝特力電子(深圳) 86-755-83298787
[Http://www.100y.com.tw](http://www.100y.com.tw)

■ 特長 : Features

- 取り付け面が絶縁されたフルモールドタイプ
Insulated package by fully molding.
- 低 V_F
Low V_F
- スイッチングスピードが非常に速い
Super high speed switching.
- プレーナー技術による高信頼性
High reliability by planer design.

■ 用途 : Applications

- 高速電力スイッチング
High speed power switching.

■ 定格と特性 : Maximum Ratings and Characteristics

● 絶対最大定格 : Absolute Maximum Ratings

Items	Symbols	Conditions	Ratings	Units
ピーク繰り返し逆電圧 Repetitive Peak Reverse Voltage	V_{RRM}		40	V
ピーク非繰り返し逆電圧 Non-Repetitive Peak Reverse Voltage	V_{RSM}	$t_w = 500\text{ns}$ duty = $\frac{1}{10}$	48	V
平均出力電流 Average Output Current	I_O	方形波, duty = $\frac{1}{2}$, $T_c = 95^\circ\text{C}$ Square wave	10*	A
サージ電流 Surge Current	I_{FSM}	正弦波 Sine Wave 10ms	120	A
接合温度 Operating Junction Temperature	T_j		-40 ~ +125	$^\circ\text{C}$
保存温度 Storage Temperature	T_{stg}		-40 ~ +125	$^\circ\text{C}$

* センタータップ平均出力電流

* average forward current of centertap full wave connection

● 電気的特性 (特に指定がない限り周囲温度 $T_a = 25^\circ\text{C}$ とする)

Electrical Characteristics ($T_a = 25^\circ\text{C}$ Unless otherwise specified)

Items	Symbols	Conditions	Max.	Units
順電圧 Forward Voltage Drop	V_{FM}	$I_{FM} = 4.0\text{A}$	0.55	V
逆電流 Reverse Current	I_{RRM}	$V_R = V_{RRM}$	5.0	mA
熱抵抗 Thermal Resistance	$R_{th(j-c)}$	接合・ケース間 平滑直流 Junction to case	3.5	$^\circ\text{C}/\text{W}$

■ 外形寸法 : Outline Drawings

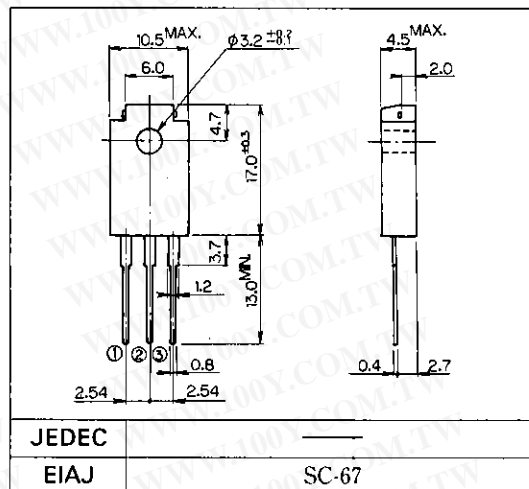

■ 電極接続

Connection Diagram

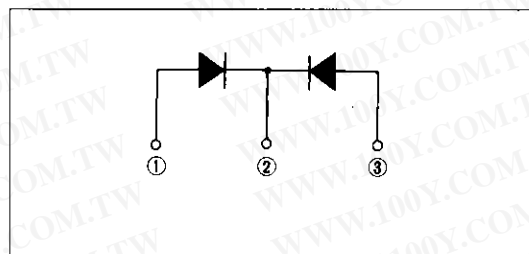

A

■特性曲线：Characteristics

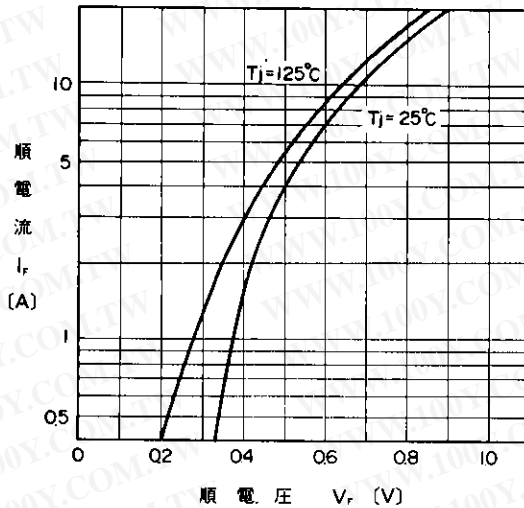

順特性 (代表特性)
 Forward Characteristics

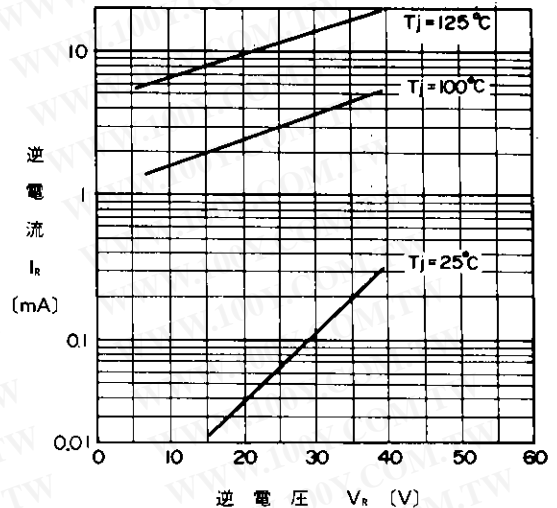

逆特性 (代表特性)
 Reverse Characteristics

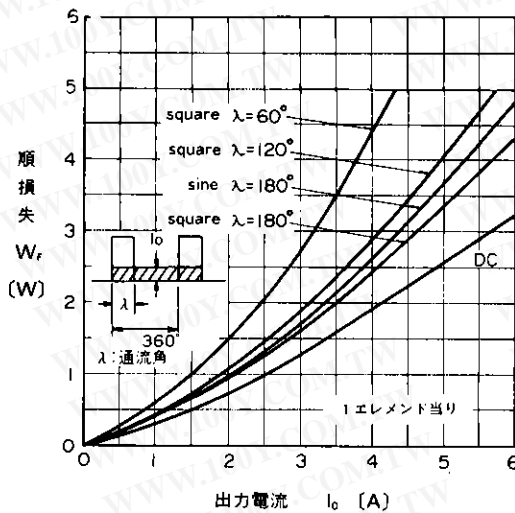

順損失特性
 Forward Power Dissipation

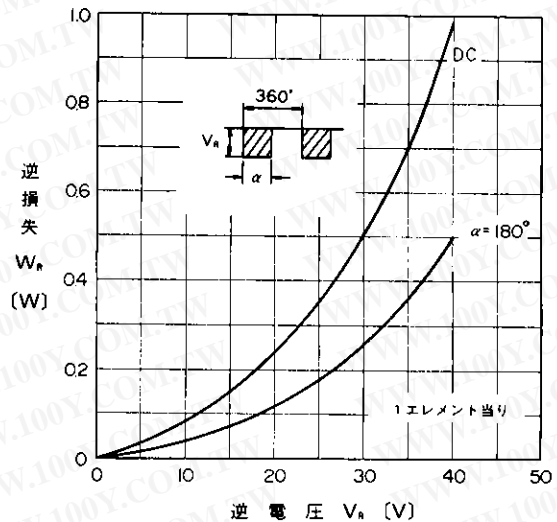

逆損失特性
 Reverse Power Dissipation

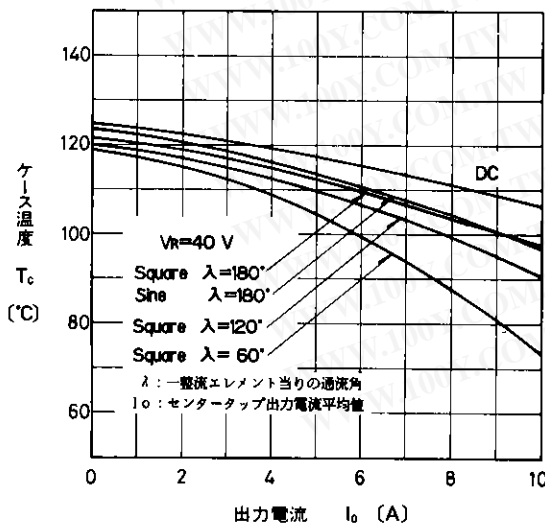

出力電流-ケース温度特性
 Output Current-Case Temperature

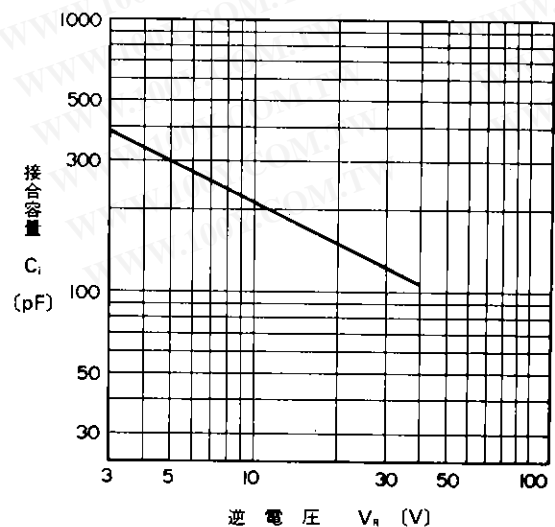

接合容量特性 (代表特性)
 Junction Capacitance Characteristics

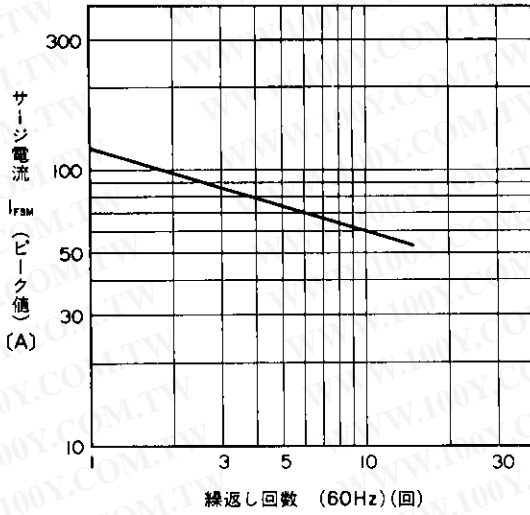

サージ電流耐量
Surge Capability

勝特力材料 886-3-5753170
 胜特力电子(上海) 86-21-54151736
 胜特力电子(深圳) 86-755-83298787
[Http://www.100y.com.tw](http://www.100y.com.tw)

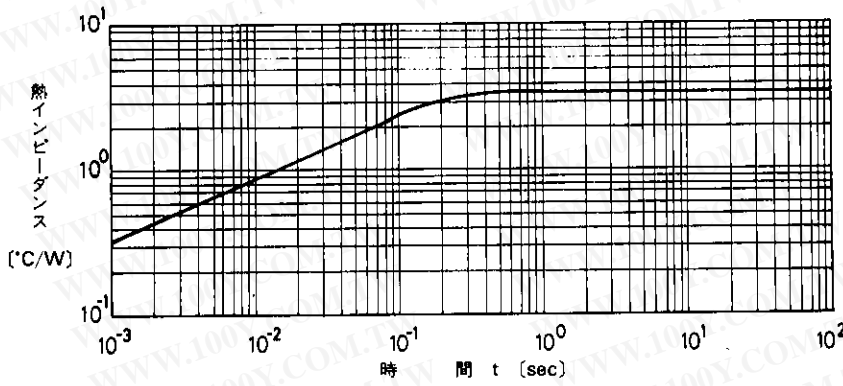

過渡熱インピーダンス
Transient Thermal Impedance